

WAREWASHER

ELECTROMECHANICAL SWITCHES
SIMPLE BODY VERSION
LOWER AND UPPER VERSION

TYPE: 16U

Accessories
BOOSTER PUMP
DVGW
DETERGENT DISPENSER
DRAIN PUMP
BREAK TANK

Spare Parts Manual



INFORMAZIONI GENERALI

Questo catalogo serve per richiedere con esattezza le parti di ricambio

Nelle ordinazioni indicare:

1) il numero dei codici dei particolari seguito dalla descrizione e la quantità desiderata;

2) Il codice alfa-numerico presente nella seconda colonna della tabella ;

I disegni delle parti di ricambio sono solo indicativi e non rappresentano il pezzo in oggetto.

I dati contenuti in questo catalogo sono indicativi e possono essere soggetti a modifiche senza impegno di preavviso.

ALLGEMEINE INFORMATIONEN

Dieser Ersatzteilkatalog dient zur genauen Angabe der Teile bei Ersatzteilbestellungen.

Bei Ersatzbestellung ist folgendes anzugeben:

1) Die Bestellnummer der Ersatzteile mit der entsprechenden Beschreibung genaue Menge;

2) Der alpha-numerischer Code auf der zweiten Reihe in dein Spcluld;

Die Zeichnungen der Ersatzteile sind nur als Hinweise gedacht und stellen nicht das betroffene Teil dar.

Bei den im Katalog angeführten Daten handelt es sich um Anhaltsdaten, die jederzeit, ohne Vorankündigung, geändert werden können.

GENERAL INFORMATION

The present spare parts order exactly the right spare parts

When ordering specify:

1) the part's code number followed by its description and quantity needed;

2) The alpha-numeric code is in the second column in the chart;

Spare parts drawings are general and do not represent the part.

The contents of this catalogue are general and can undergo changes without prior notice.

INFORMACIONES GENERALES

El presente catálogo sirve para pedir con exactitud las partes de repuesto

En los pedidos se debe indicar:

1) el número de código de la parte y a continuación la descripción cantidad deseada;

2) El código alfanumerico presente en la segnada columna de la tabla;

Los diseños de las partes de recambio son solo indicativos y no representan la pieza en cuestión.

Los datos contenidos en el presente catálogo son indicativos y pueden modificarse sin aviso previo.

INFORMATIONS GENERALES

Ce catalogue permet de commander correctement les pièces détachées

Les commandes doivent être passées en indiquant:

1) le numero de code des pièces détachées suivi de leur description quantité désirée;

2) le code alphanumérique dans la deuxième colonne du tableau;

Les plans des pièces détachées sont fournis seulement à titre indicatif et ne représentent pas la pièce concernée.

Les données de ce catalogue sont citées seulement à titre indicatif et peuvent être l'objet de modifications sans avis préalable.

ESEMPIO
EXAMPLE
EXEMPLE
BEISPIEL

Rif.	Codici
MODULE:Particolari	
10505	540903
10510	540908
10515	15065/A
10520	540086
10525	540028

Note

Tutte le informazioni riportate si intendono aggiornate alla data di stampa. Il Produttore si riserva il diritto di apportare qualsiasi modifica richiesta dallo sviluppo evolutivo dei suddetti prodotti.

Per la sicurezza, la garanzia, l'affidabilità ed il valore della lavastoviglie usa solo ricambi originali. **Per alcuni codici, sono richieste quantità minime d'ordine.**

Attenzione

Questo libretto è parte integrante della lavastoviglie e, in caso di passaggio di proprietà, deve essere consegnato al nuovo acquirente.

Remarque

Toutes les informations contenues dans ce manuel s'entendent mises à jour à la date d'impression. En raison du développement constant de ses produits, usine se réserve le droit d'apporter à tout instant les modifications qu'elle jugera utiles.

Pour la sécurité, la garantie, la fiabilité et la valeur de votre lavevaisselles n'utilisez que des pièces de rechange d'origine. **Pour quelque référence on demande un minimum de pièces par commande**

Attention

Ce manuel doit être considéré comme partie intégrante de la lavevaisselles, en cas de transfert de propriété, doit toujours être remis au nouveau propriétaire.

Note

The information contained herein is valid at the time of going to print. The Company reserves the right to make any changes required by the future development of the above-mentioned products.

For your safety, as well as to preserve the warranty reliability and worth of your dishwashers, use original spare parts only. **For some codes a minimum quantity for order is required.**

Warning

This manual forms an integral part of the dishwashers and - if a transfer of title occurs - must always be handed over to the new owner.

Hinweis

Die Der Hersteller behält sich das Recht vor, jegliche, durch eine Weiterentwicklung der genannten Produkte bedingte Änderungen vornehmen zu können.

Verwenden Sie für Ihre Sicherheit, die Garantie, die Zuverlässigkeit und den Wert Ihrer machine originale Ersatzteile. **Für bestimmte Code nummer werden mindesten bestellungen verlangt.**

Achtung

Diese Betriebsanleitung ist Bestandteile des machine und muss bei seinem Weiterverkauf dem neuen Besitzer ausgehändigt werden.



Code 999XYYYY **CL/Part**

Model DESCRIPTION

S/N 04012345 **Type**

400VAC3N 50HZ 8A
3500W 500W

 16A

IPX3

Pressione Dinamica alimentazione idrica **200-500**
 Pression dynamique arrivee d'eau
 Dynamic pressure water supply
 Dymanischer Druck asserreinlauf

Pressione dinamica vapore saturo
 Pression dynamique vapeur satuee
 Dymanischer Druck gesattigter Dampf
 Pression Dinamica Vapor Saturado

TECHICAL SPECIFICATION

MADE IN ITALY

Temperatura massima acqua in ingresso **60°C**
 Temperature max eau a l'entre
 Maximale Temperatur Wasseranschlu
 Maximum Water temperature in-feeding

Model 

S/N 

CODE 999 XX YYYY

FAMIGLIA PRODOTTO
 FAMILY PRODUCT
 FAMILLE DU PRODUIT
 FAMILIA PRODUCTO
 FAMILIE DES PRODUKTES

CODICE MODELLO
 CODE MODEL
 CODE ARTICLE
 CODIGO MODELO
 KODE VON MODELL

S/N 04 012345

ANNO
 YEAR
 ANNÉE
 AN^o
 JAHR

NUMERO DI SERIE
 SERIAL NUMBER
 NUMÉRO DI SÉRIE
 NUMERO DI SERIE
 SERIENNUMMER

1. Spare parts

General body parts.....	7
Lockup system	11
Control panel and switches.....	13
Electric control components.....	15
Solenoid valve group	17
Break Tank	19
Booster pump.....	21
DVGW	23
Rinse aid dispenser group.....	25
Boiler group	27
Connection group	29
Wash pump	31
Dosing detergent group.....	33
Drain pump group.....	35
Pressure switch group with air trap ...	37
Turret group with rotating arms	39

Turret group with rotating arms 43

1.1 Voltage codes

Volt	Voltage code
A	3/N/PE~380-400V 50-60Hz
D	3/PE~200-210V 50-60Hz
F	2/PE~220-240V 50-60Hz
G	3/N/PE~415V 50-60Hz
H	3/PE~220-230V 50-60Hz
K	3/PE~380-400V 50-60Hz
L	3/PE~415V 50-60Hz
M	3/PE~440V 60Hz
P	1/N/PE~220-230V 50-60Hz
R	2/PE~220-240V 50-60Hz
U	1/N/PE~240V 50-60Hz
V	3/PE~240V 50-60Hz
W	1/N/PE~100-110V 50-60Hz

1.2 Product codes

Product code	Full name
Model codes	
em	ELECTROMECHANICAL SWITCHES
mc	SIMPLE BODY VERSION
uw	LOWER AND UPPER VERSION
Type codes	
16U	16U
Accessory codes	
bp	BOOSTER PUMP
dvgw	DVGW
dd	DETERGENT DISPENCER
dp	DRAIN PUMP
bt	BREAK TANK

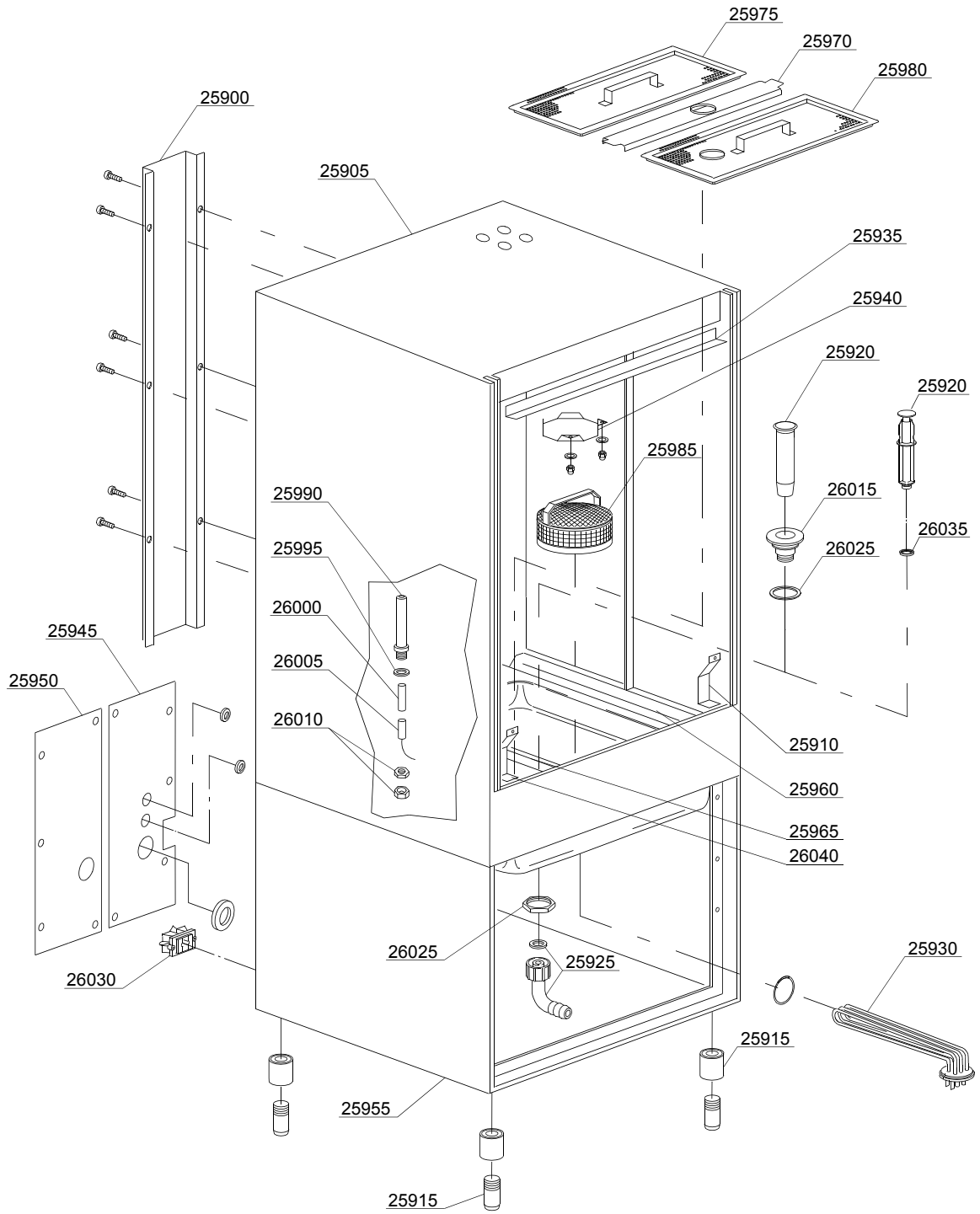

01_022_e

Spare parts

ID	P-code	SN from	SN to	Mod.	Acces.	Volt	Description
Module:General body parts							
25900	22224		-				Back panel
25905	22205		-				Body
25910	22254		-				Right/left lower splash guard
25915	15116		-				Foot
25920	500619		-				Overflow pipe
25920	22251		-				Overflow pipe
25925	15613		-				Elbow 1/4"
25930	15047/A		-			A,H,K,L,P,R,U ,V	heating element 2,7/2,94KW 230/240V 3
25935	22231		-				Upper splash guard
25940	22232		-				Chimney splash guard
25945	22228		-				Right back panel
25950	22230		-				Left back panel
25955	22204		-				Base
25960	22209		-				Right internal slide
25965	22209/A		-				Left internal slide
25970	75926		-				Sleeper holder-filter
25975	75626		-				Surface half-filter
25980	75625		-				Half-filter with hole
25985	15911		-				Stainless steel filter
25990	22213		-				Reed-holder
25995	10200171		-				Gasket 17x25x2 (minimum 10 pieces)
26000	22213/A		-				Reed-holder spacer
26005	2000309		-				Sensor
26010	22214		-				Nut
26015	10200113		-				Drain coupling
26020	10200173		-				Gasket 75x58x2 (minimum 2 pieces)
26025	10200114		-				Drain pipe nut
26030	15065/A		-				Cable sheath

em=ELECTROMECHANICAL SWITCHES, mc=SIMPLE BODY VERSION, uw=LOWER AND UPPER VERSION
16U=16U

bp=BOOSTER PUMP, dvgw=DVGW, dd=DETERGENT DISPENCER, dp=DRAIN PUMP, bt=BREAK TANK

A=3/N/PE~380-400V 50-60Hz, D=3/PE~200-210V 50-60Hz, F=2/PE~220-240V 50-60Hz, G=3/N/PE~415V 50-60Hz,
H=3/PE~220-230V 50-60Hz, K=3/PE~380-400V 50-60Hz, L=3/PE~415V 50-60Hz, M=3/PE~440V 60Hz, P=1/N/PE~220-
230V 50-60Hz, R=2/PE~220-240V 50-60Hz, U=1/N/PE~240V 50-60Hz, V=3/PE~240V 50-60Hz, W=1/N/PE~100-110V
50-60Hz

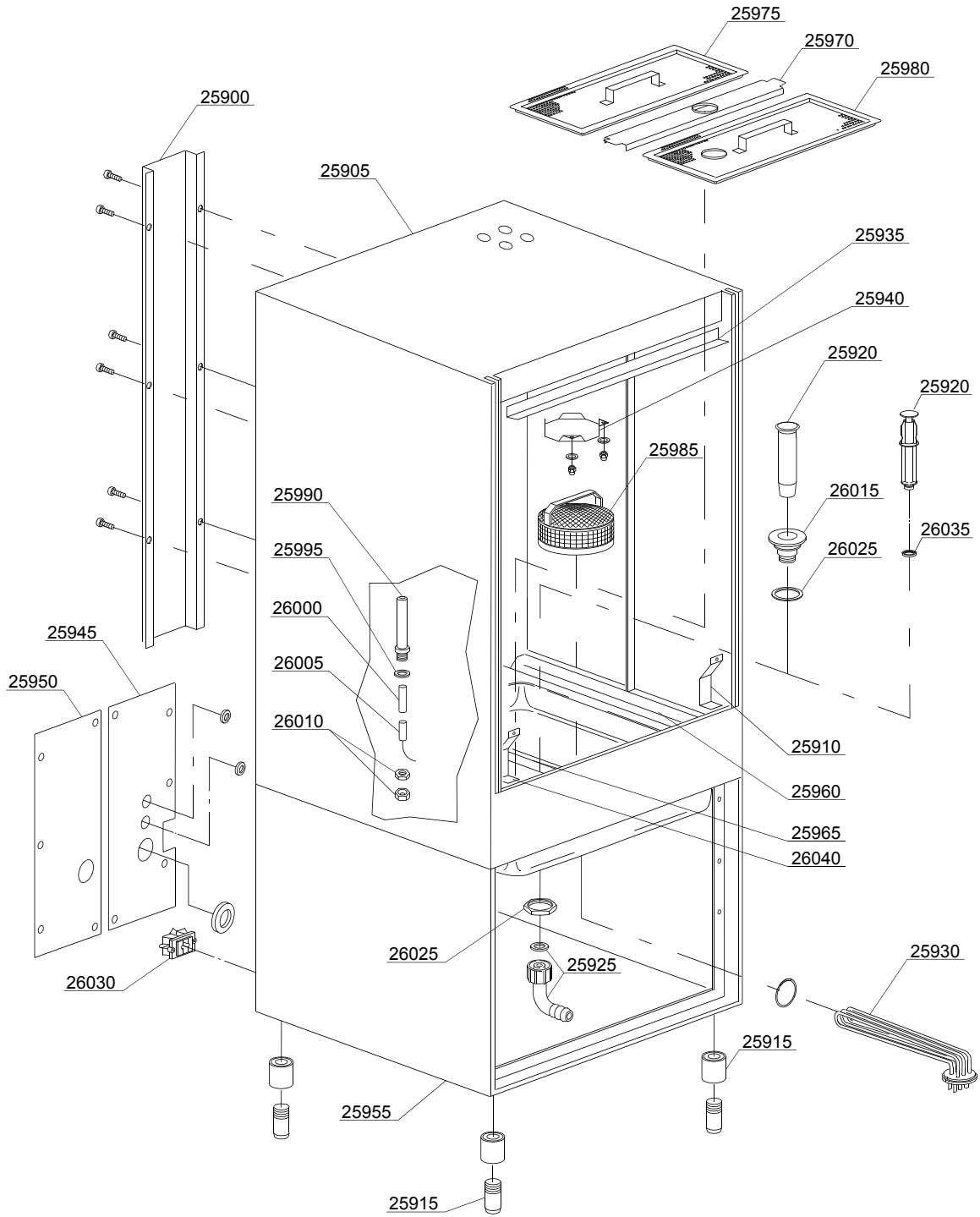

01_022_e

Spare parts

ID	P-code	SN from	SN to	Mod.	Acces.	Volt	Description
Module:General body parts							
26035	13021		-				DEM 40 O-ring (minimum 2 pieces)
26040	22255		-				Left splash guard

em=ELECTROMECHANICAL SWITCHES, mc=SIMPLE BODY VERSION, uw=LOWER AND UPPER VERSION
16U=16U

bp=BOOSTER PUMP, dvgw=DVGW, dd=DETERGENT DISPENCER, dp=DRAIN PUMP, bt=BREAK TANK

A=3/N/PE~380-400V 50-60Hz, D=3/PE~200-210V 50-60Hz, F=2/PE~220-240V 50-60Hz, G=3/N/PE~415V 50-60Hz,
H=3/PE~220-230V 50-60Hz, K=3/PE~380-400V 50-60Hz, L=3/PE~415V 50-60Hz, M=3/PE~440V 60Hz, P=1/N/PE~220-
230V 50-60Hz, R=2/PE~220-240V 50-60Hz, U=1/N/PE~240V 50-60Hz, V=3/PE~240V 50-60Hz, W=1/N/PE~100-110V
50-60Hz

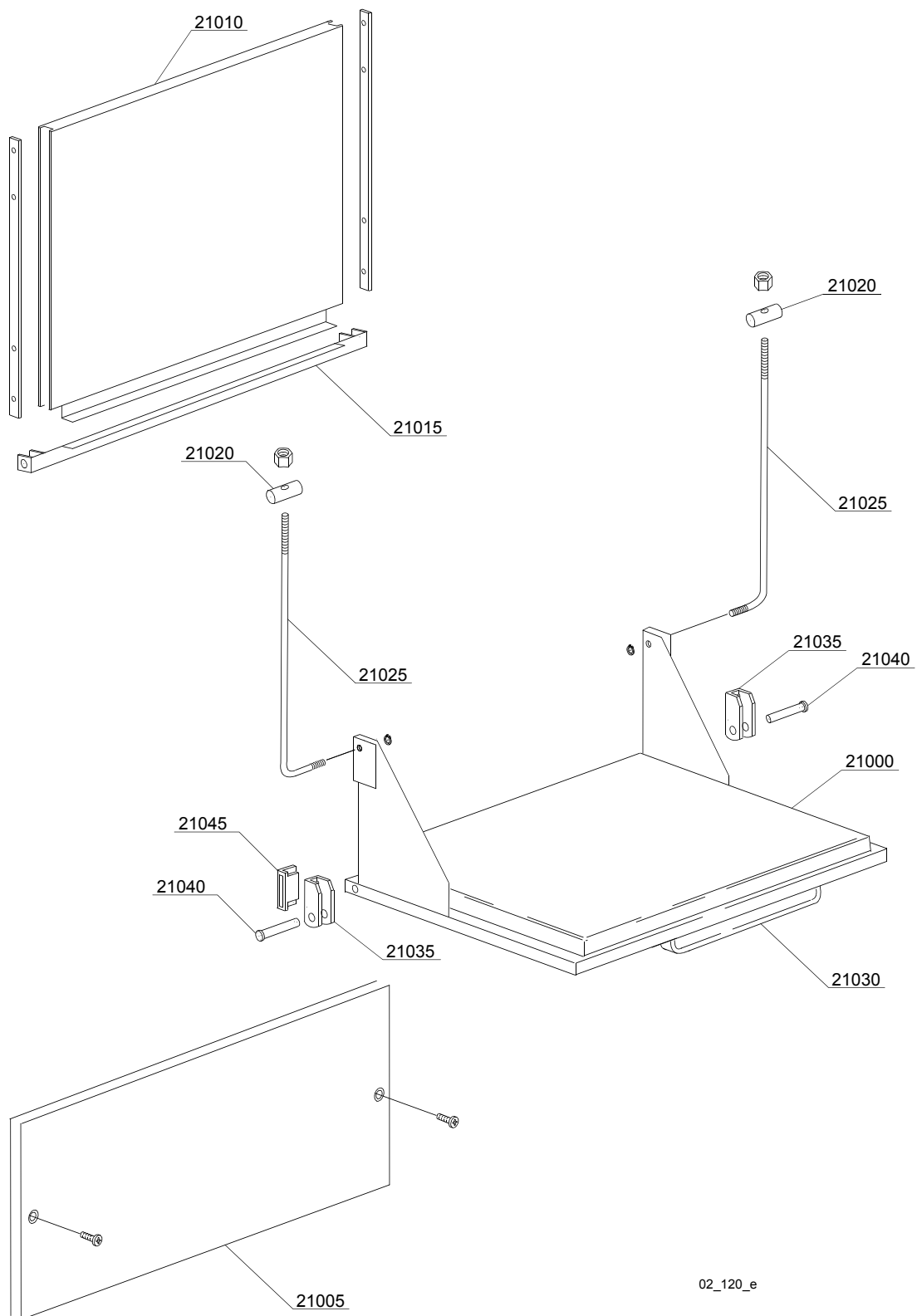

02_120_e

Spare parts

ID	P-code	SN from	SN to	Mod.	Acces.	Volt	Description
Module: Lockup system							
21000	22206		-				Door with steel handle
21005	22208		-				Lower door
21010	22207		-				Upper door
21015	22233		-				Levers support
21020	22219		-				Pin
21025	22220		-				Door rod
21030	22215		-				Stainless steel handle
21035	22206/B		-				Door hinge
21040	22220/A		-				Pin for door
21045	80232		-				Door magnet

em=ELECTROMECHANICAL SWITCHES, mc=SIMPLE BODY VERSION, uw=LOWER AND UPPER VERSION
16U=16U

bp=BOOSTER PUMP, dvgw=DVGW, dd=DETERGENT DISPENCER, dp=DRAIN PUMP, bt=BREAK TANK

A=3/N/PE~380-400V 50-60Hz, D=3/PE~200-210V 50-60Hz, F=2/PE~220-240V 50-60Hz, G=3/N/PE~415V 50-60Hz,
H=3/PE~220-230V 50-60Hz, K=3/PE~380-400V 50-60Hz, L=3/PE~415V 50-60Hz, M=3/PE~440V 60Hz, P=1/N/PE~220-
230V 50-60Hz, R=2/PE~220-240V 50-60Hz, U=1/N/PE~240V 50-60Hz, V=3/PE~240V 50-60Hz, W=1/N/PE~100-110V
50-60Hz

03_025be

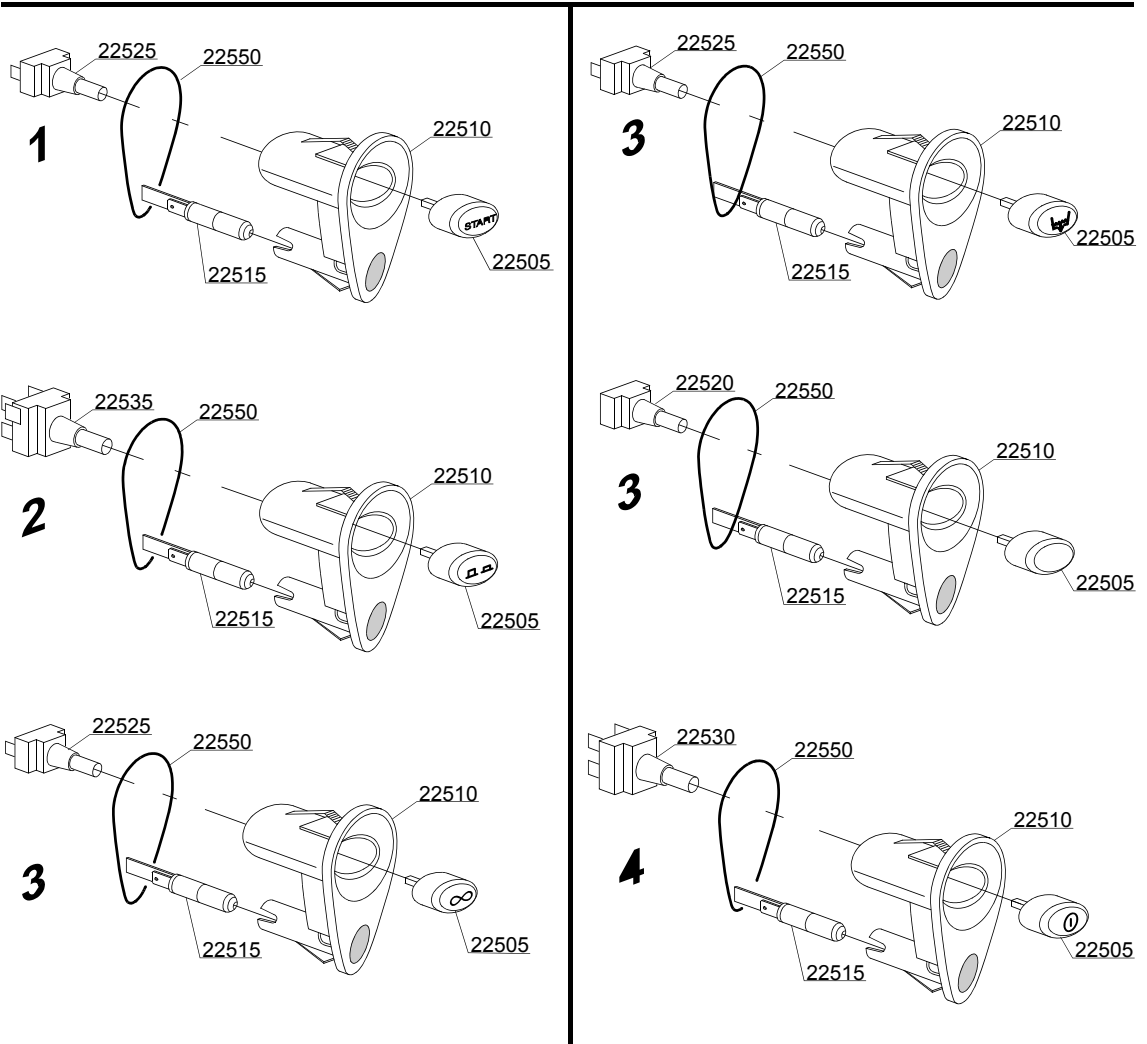
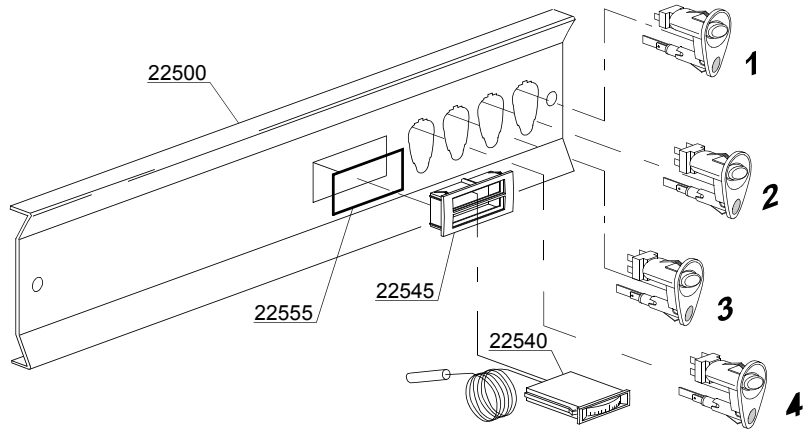

Spare parts

ID	P-code	SN from	SN to	Mod.	Acces.	Volt	Description
Module:Control panel and switches							
22500	23234		-	em			Star control panel
22505	89343		-	em	dp		Drain pump push button
22505	89342		-	em			Time selector switch push button
22505	89341		-	em			Start push button
22505	89348		-	em			Blind push button
22505	89340		-	em			ON-OFF push button
22510	89300		-	em			Push button support
22515	15826		-	em			Lamp, transparent
22520	15844		-	em			Push button support
22525	15813		-	em			16A unipolar switch
22530	15812		-	em			16A switch
22530	15800		-	em			16A bipolar switch
22535	15811		-	em			16A bipolar switch
22535	15811/A		-	em			16A bipolar switch
22540	10500011		-	em			Thermometer
22545	89306		-	em			Double thermometer support
22550	89332		-	em			OR O-ring (minimum 10 pieces)
22555	89331		-	em			OR O-ring (minimum 5 pieces)

em=ELECTROMECHANICAL SWITCHES, mc=SIMPLE BODY VERSION, uw=LOWER AND UPPER VERSION
16U=16U

bp=BOOSTER PUMP, dvgw=DVGW, dd=DETERGENT DISPENCER, dp=DRAIN PUMP, bt=BREAK TANK

A=3/N/PE~380-400V 50-60Hz, D=3/PE~200-210V 50-60Hz, F=2/PE~220-240V 50-60Hz, G=3/N/PE~415V 50-60Hz,
H=3/PE~220-230V 50-60Hz, K=3/PE~380-400V 50-60Hz, L=3/PE~415V 50-60Hz, M=3/PE~440V 60Hz, P=1/N/PE~220-
230V 50-60Hz, R=2/PE~220-240V 50-60Hz, U=1/N/PE~240V 50-60Hz, V=3/PE~240V 50-60Hz, W=1/N/PE~100-110V
50-60Hz

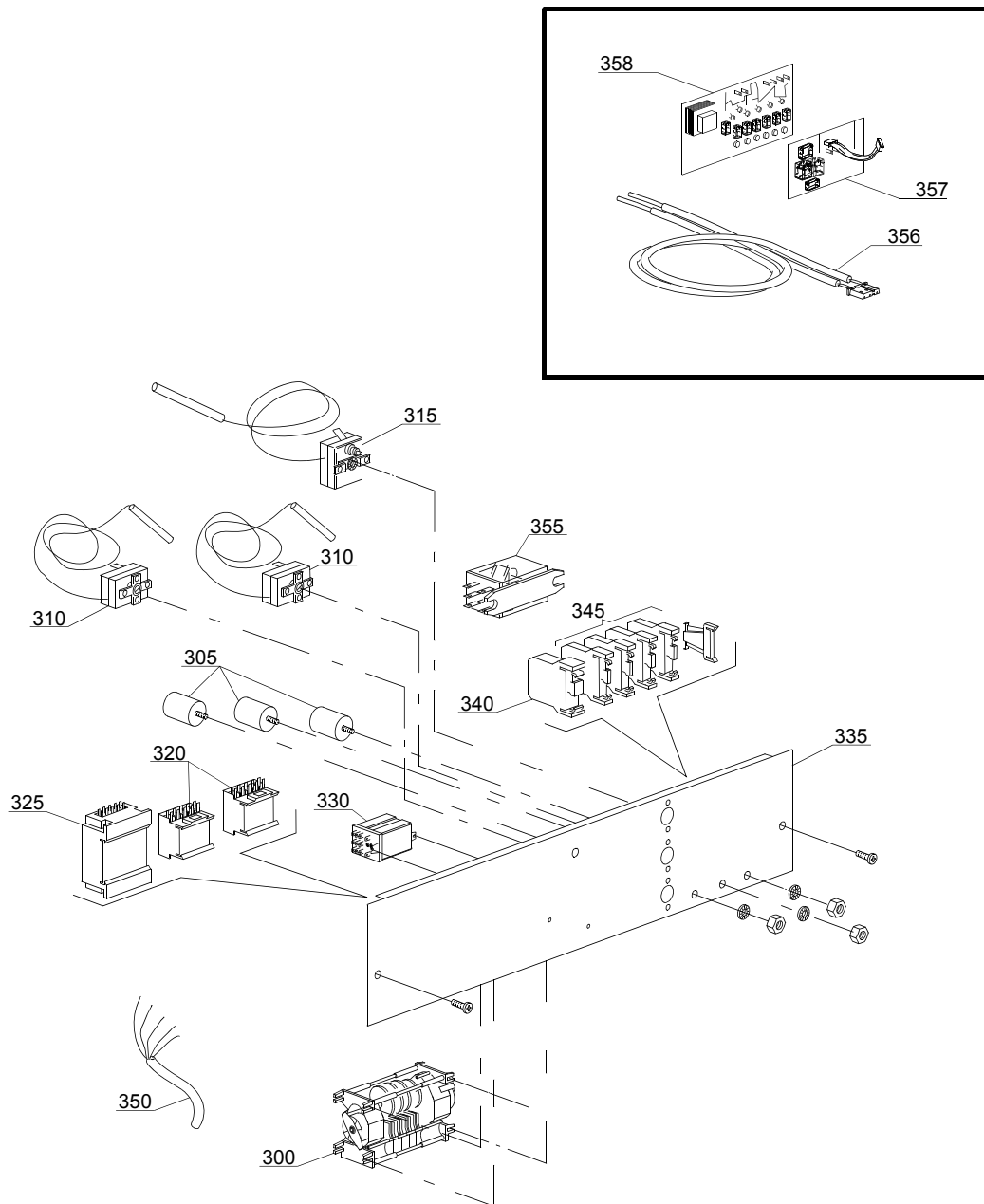

04_011_e

Spare parts

ID	P-code	SN from	SN to	Mod.	Acces.	Volt	Description
Module:Electric control components							
300	22011		-	em		A,H,K,P	120/240" timer with thermostop
300	22011/B		-	em		D	120/240" timer - 200V 60Hz
305	15149		-	em		A,H,K,P	Filter F3
310	10707/1		-	em		A,H,K,P	0-90°C thermostat
315	2000430		-	em		A,H,K,P	Thermostat
320	15086		-	em		A,H,K,P	Contactora 230 V
325	10300050		-	em		A,H,K,P	Contactora 25A/12A 4NA 230V
330	16037		-	em		A,H,K,P	16A bipolar relay 230V 50/60Hz
335	23214			em			Electric component panel
340	10300401		-	em			Clamp
345	10300403		-	em			Clamp
350	80200		-	em		A,G	Power supply cable 5x4x3400
350	75359		-	em		D,F,H,K,L,M,R,V	4x6 flame-retardant cable
350	15145		-	em		D,F,H,K,L,M,R,V	4x4x2500 cable
355	15620		-	em	dp		Bipolar relay in deviation

em=ELECTROMECHANICAL SWITCHES, mc=SIMPLE BODY VERSION, uw=LOWER AND UPPER VERSION
16U=16U

bp=BOOSTER PUMP, dvgw=DVGW, dd=DETERGENT DISPENCER, dp=DRAIN PUMP, bt=BREAK TANK

A=3/N/PE~380-400V 50-60Hz, D=3/PE~200-210V 50-60Hz, F=2/PE~220-240V 50-60Hz, G=3/N/PE~415V 50-60Hz,
H=3/PE~220-230V 50-60Hz, K=3/PE~380-400V 50-60Hz, L=3/PE~415V 50-60Hz, M=3/PE~440V 60Hz, P=1/N/PE~220-
230V 50-60Hz, R=2/PE~220-240V 50-60Hz, U=1/N/PE~240V 50-60Hz, V=3/PE~240V 50-60Hz, W=1/N/PE~100-110V
50-60Hz

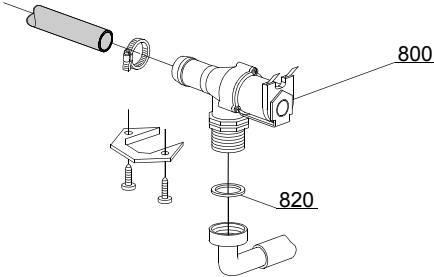

05_005_e

Spare parts

ID	P-code	SN from	SN to	Mod.	Acces.	Volt	Description
Module:Solenoid valve group							
800	30001000		-				Solenoid valve
820	N.C.		-				Pression reducing valve

em=ELECTROMECHANICAL SWITCHES, mc=SIMPLE BODY VERSION, uw=LOWER AND UPPER VERSION
16U=16U

bp=BOOSTER PUMP, dvgw=DVGW, dd=DETERGENT DISPENCER, dp=DRAIN PUMP, bt=BREAK TANK

A=3/N/PE~380-400V 50-60Hz, D=3/PE~200-210V 50-60Hz, F=2/PE~220-240V 50-60Hz, G=3/N/PE~415V 50-60Hz,
H=3/PE~220-230V 50-60Hz, K=3/PE~380-400V 50-60Hz, L=3/PE~415V 50-60Hz, M=3/PE~440V 60Hz, P=1/N/PE~220-
230V 50-60Hz, R=2/PE~220-240V 50-60Hz, U=1/N/PE~240V 50-60Hz, V=3/PE~240V 50-60Hz, W=1/N/PE~100-110V
50-60Hz

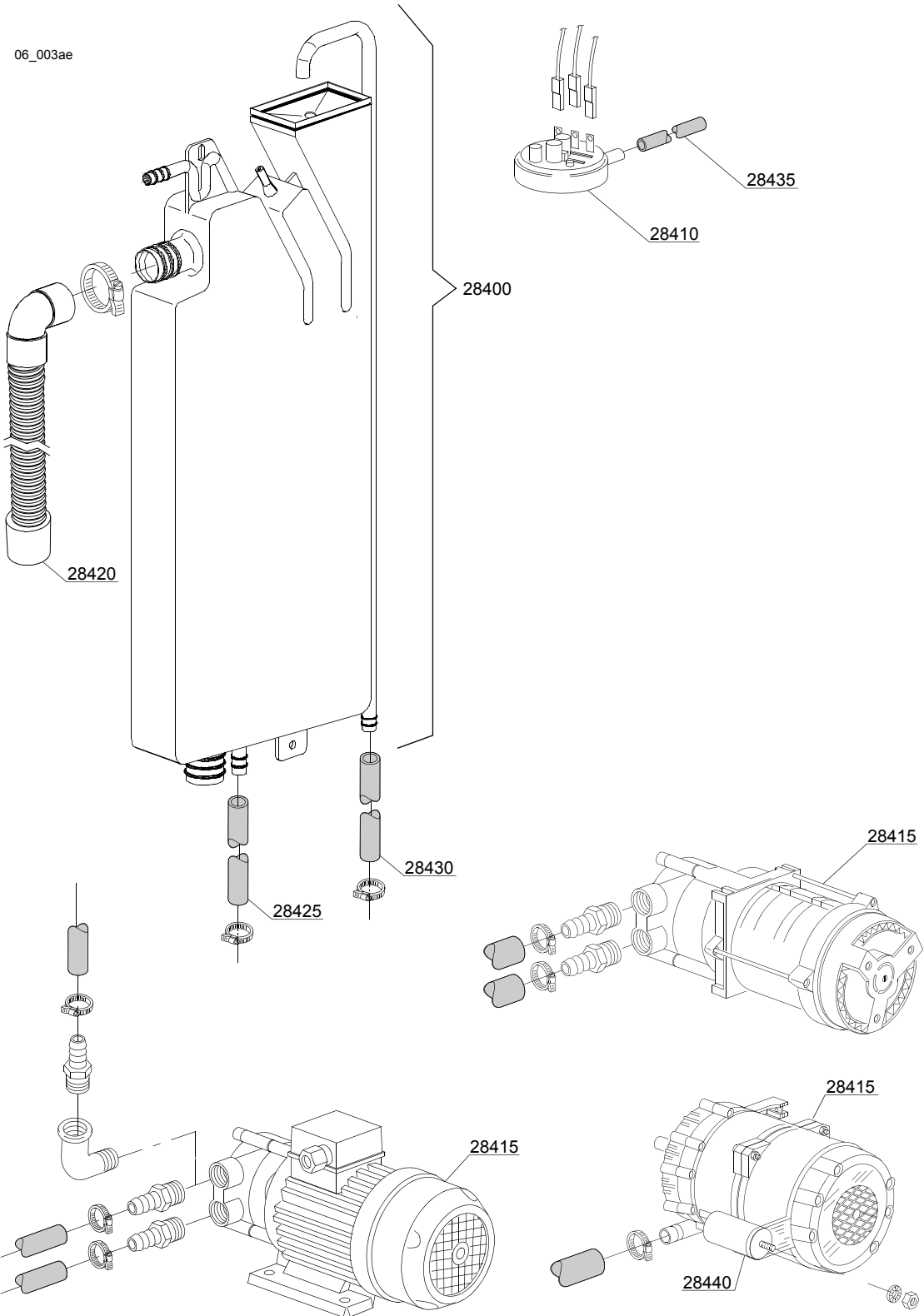

Spare parts

ID	P-code	SN from	SN to	Mod.	Acces.	Volt	Description
Module:Break Tank							
28400	15720		-	em	bt		Break tank assembly
28410	10706/A		-	em	bt		47-27 pressure switch
28415	15100		-	em	bt	A,F,G,H, K,L,P,R, U,V	Booster pump 0,5Hp/0,4kW 220/240V 50Hz
28415	15100/D		-	em	bt		Booster pump 220/240V - body pumps in plastic
28415	15100/D		-	em	bt		Booster pump 220/240V - body pumps in brass
28420	15721		-	em	bt		BT long pipe L=1070
28420	15722		-	em	bt		BT middle pipe L=920
28420	15723		-	em	bt		BT small pipe L=690
28425	2907350		-	em	bt		12x20 EPDM rubber hose
28430	2907352		-	em	bt		PVC WRAS rubber hose
28435	14508		-	em	bt		4,5x9 EPDM rubber hose
28440	10702		-	em	bt		5 uF condenser - 450V

em=ELECTROMECHANICAL SWITCHES, mc=SIMPLE BODY VERSION, uw=LOWER AND UPPER VERSION
16U=16U

bp=BOOSTER PUMP, dvgw=DVGW, dd=DETERGENT DISPENCER, dp=DRAIN PUMP, bt=BREAK TANK

A=3/N/PE~380-400V 50-60Hz, D=3/PE~200-210V 50-60Hz, F=2/PE~220-240V 50-60Hz, G=3/N/PE~415V 50-60Hz,
H=3/PE~220-230V 50-60Hz, K=3/PE~380-400V 50-60Hz, L=3/PE~415V 50-60Hz, M=3/PE~440V 60Hz, P=1/N/PE~220-
230V 50-60Hz, R=2/PE~220-240V 50-60Hz, U=1/N/PE~240V 50-60Hz, V=3/PE~240V 50-60Hz, W=1/N/PE~100-110V
50-60Hz

07_002_e

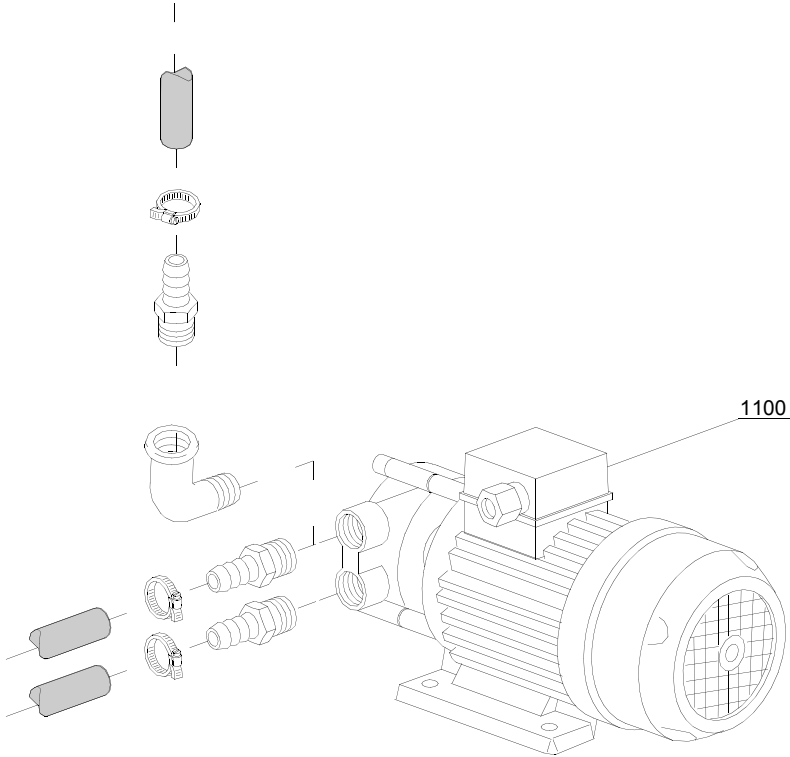

Spare parts

ID	P-code	SN from	SN to	Mod.	Acces.	Volt	Description
Module:Booster pump							
1100	15100		-		bp	A,F,G,H,K, L,P,R,U,V	Booster pump 0,5HP/0,375kW 50Hz 220-240V
1100	15100/A		-		bp	A,F,G,H,K, L,P,R,U,V	Booster pump - 0,5HP/ 0,37kW 60Hz

em=ELECTROMECHANICAL SWITCHES, mc=SIMPLE BODY VERSION, uw=LOWER AND UPPER VERSION
16U=16U

bp=BOOSTER PUMP, dvgw=DVGW, dd=DETERGENT DISPENCER, dp=DRAIN PUMP, bt=BREAK TANK

A=3/N/PE~380-400V 50-60Hz, D=3/PE~200-210V 50-60Hz, F=2/PE~220-240V 50-60Hz, G=3/N/PE~415V 50-60Hz,
H=3/PE~220-230V 50-60Hz, K=3/PE~380-400V 50-60Hz, L=3/PE~415V 50-60Hz, M=3/PE~440V 60Hz, P=1/N/PE~220-230V 50-60Hz, R=2/PE~220-240V 50-60Hz, U=1/N/PE~240V 50-60Hz, V=3/PE~240V 50-60Hz, W=1/N/PE~100-110V 50-60Hz

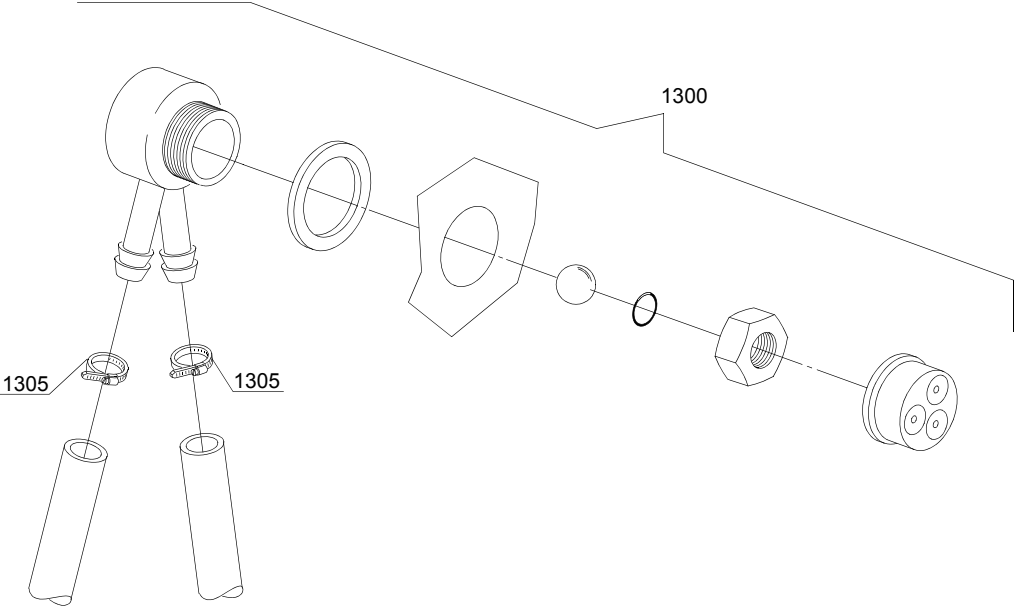

Spare parts

ID	P-code	SN from	SN to	Mod.	Acces.	Volt	Description
Module:DVGW							
1300	999900006		-		dvgw		DVGW assembly
1305	11807		-		dvgw		12/22 clamp (minimum 3 pieces)

em=ELECTROMECHANICAL SWITCHES, mc=SIMPLE BODY VERSION, uw=LOWER AND UPPER VERSION
16U=16U

bp=BOOSTER PUMP, dvgw=DVGW, dd=DETERGENT DISPENCER, dp=DRAIN PUMP, bt=BREAK TANK

A=3/N/PE~380-400V 50-60Hz, D=3/PE~200-210V 50-60Hz, F=2/PE~220-240V 50-60Hz, G=3/N/PE~415V 50-60Hz,
H=3/PE~220-230V 50-60Hz, K=3/PE~380-400V 50-60Hz, L=3/PE~415V 50-60Hz, M=3/PE~440V 60Hz, P=1/N/PE~220-
230V 50-60Hz, R=2/PE~220-240V 50-60Hz, U=1/N/PE~240V 50-60Hz, V=3/PE~240V 50-60Hz, W=1/N/PE~100-110V
50-60Hz

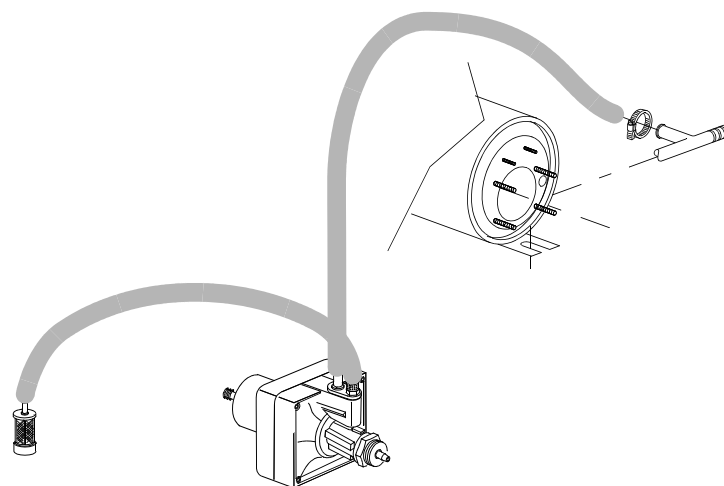
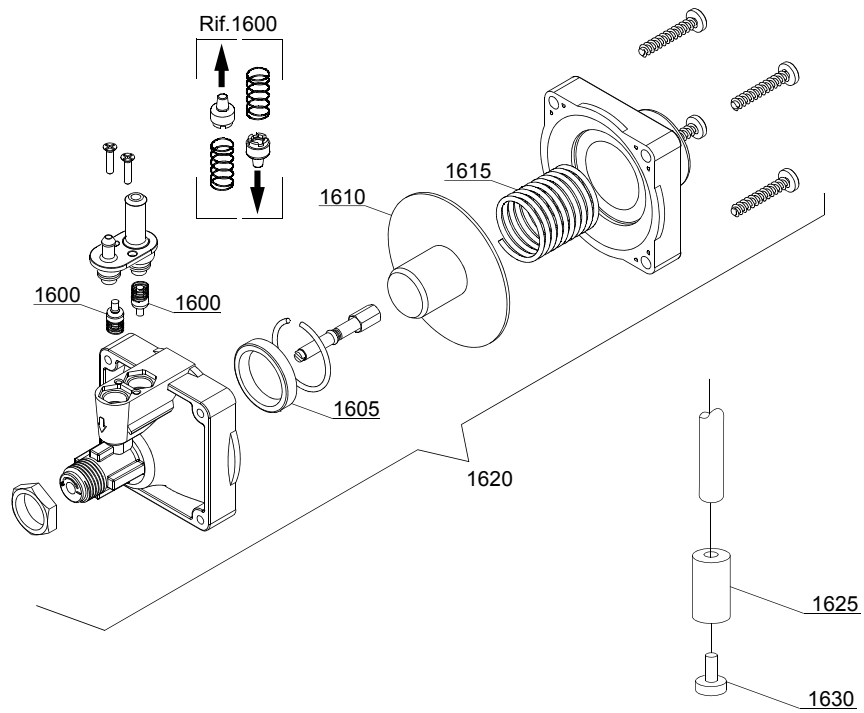

10_003_e

Spare parts

ID	P-code	SN from	SN to	Mod.	Acces.	Volt	Description
Module: Rinse aid dispenser group							
1600	10805		-				Tecnopro non return valve
1605	10806		-				Ø22 O-ring
1610	10807		-				Membrane
1615	10808		-				Spring
1620	10599999		-				Rinse aid pump
1625	12525		-				Counter-weight
1630	15058		-				Suction filter (minimum 3 pieces)

em=ELECTROMECHANICAL SWITCHES, mc=SIMPLE BODY VERSION, uw=LOWER AND UPPER VERSION
16U=16U

bp=BOOSTER PUMP, dvgw=DVGW, dd=DETERGENT DISPENSER, dp=DRAIN PUMP, bt=BREAK TANK

A=3/N/PE~380-400V 50-60Hz, D=3/PE~200-210V 50-60Hz, F=2/PE~220-240V 50-60Hz, G=3/N/PE~415V 50-60Hz,
H=3/PE~220-230V 50-60Hz, K=3/PE~380-400V 50-60Hz, L=3/PE~415V 50-60Hz, M=3/PE~440V 60Hz, P=1/N/PE~220-
230V 50-60Hz, R=2/PE~220-240V 50-60Hz, U=1/N/PE~240V 50-60Hz, V=3/PE~240V 50-60Hz, W=1/N/PE~100-110V
50-60Hz

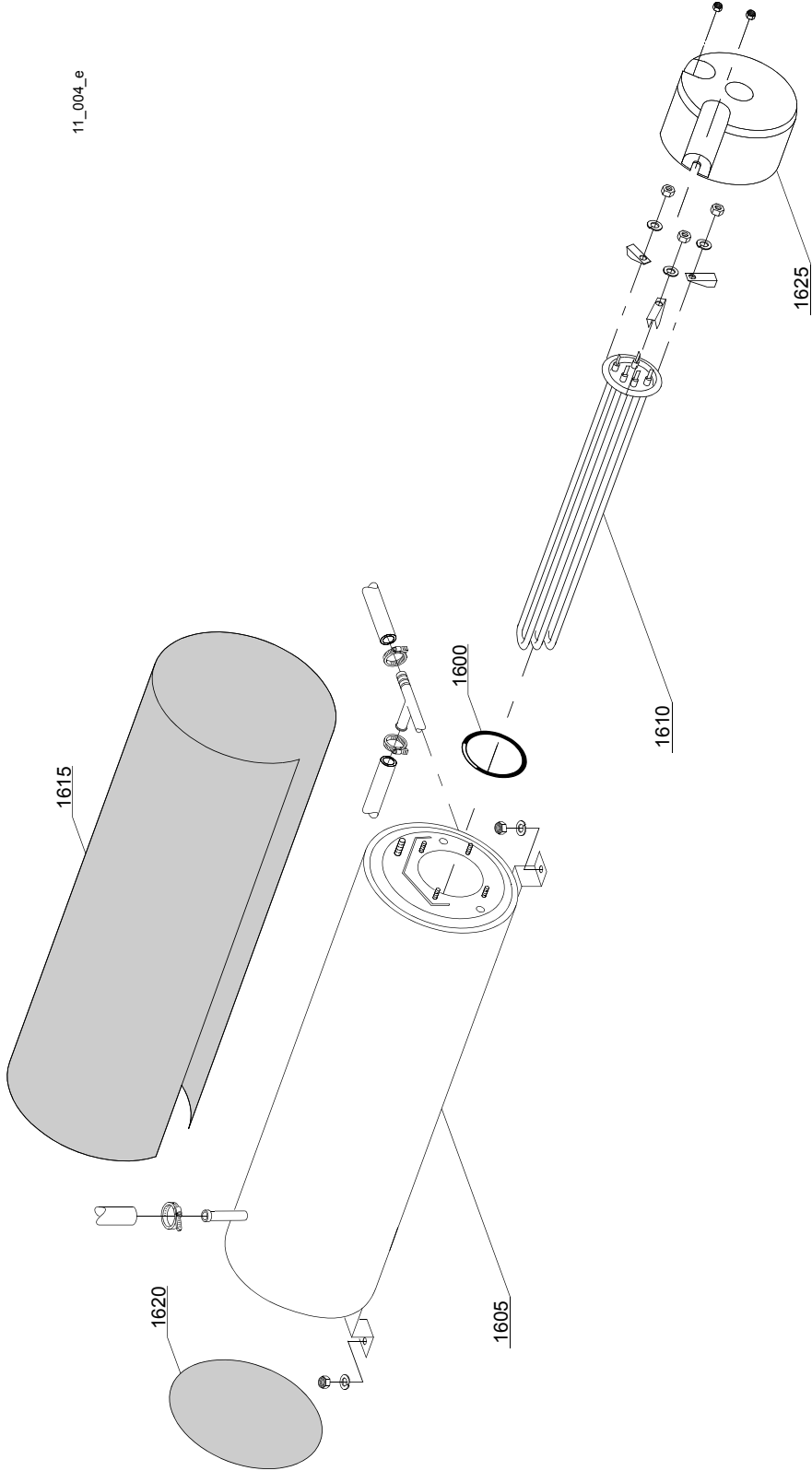

Spare parts

ID	P-code	SN from	SN to	Mod.	Acces.	Volt	Description
Module:Boiler group							
1600	13015		-				Gasket OR 6225 (minimum 5 pieces)
1605	22002		-				Boiler
1610	30001010		-			A,F,G,H,K,L,P,R,U,V	Heating element 6/6,53KW 230/240V 3
1610	30001011		-			A,F,G,H,K,L,P,R,U,V	Heating element 9/9,8KW 230/240V 3
1615	30002030		-				Insulation boiler
1620	75205		-				Ø160 end piece (minimum 2 pieces)

em=ELECTROMECHANICAL SWITCHES, mc=SIMPLE BODY VERSION, uw=LOWER AND UPPER VERSION

16U=16U

bp=BOOSTER PUMP, dvgw=DVGW, dd=DETERGENT DISPENCER, dp=DRAIN PUMP, bt=BREAK TANK

A=3/N/PE~380-400V 50-60Hz, D=3/PE~200-210V 50-60Hz, F=2/PE~220-240V 50-60Hz, G=3/N/PE~415V 50-60Hz, H=3/PE~220-230V 50-60Hz, K=3/PE~380-400V 50-60Hz, L=3/PE~415V 50-60Hz, M=3/PE~440V 60Hz, P=1/N/PE~220-230V 50-60Hz, R=2/PE~220-240V 50-60Hz, U=1/N/PE~240V 50-60Hz, V=3/PE~240V 50-60Hz, W=1/N/PE~100-110V 50-60Hz

12_007_e

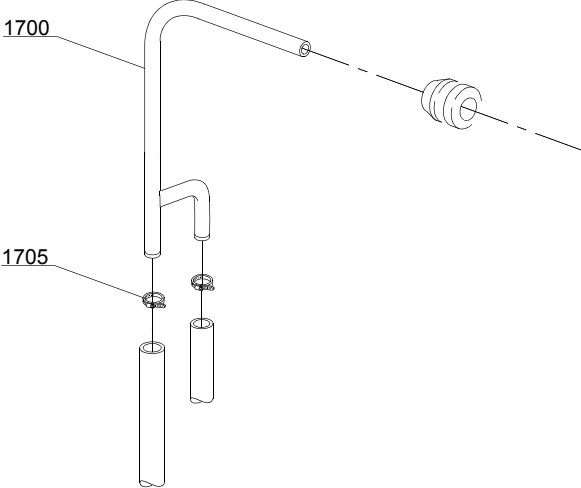

Spare parts

ID	P-code	SN from	SN to	Mod.	Acces.	Volt	Description
Module:Connection group							
1700	15045/B		-				3 ways connection
1705	11807		-				Clamp 12-22 (minimum 3 pieces)

em=ELECTROMECHANICAL SWITCHES, mc=SIMPLE BODY VERSION, uw=LOWER AND UPPER VERSION
16U=16U

bp=BOOSTER PUMP, dvgw=DVGW, dd=DETERGENT DISPENCER, dp=DRAIN PUMP, bt=BREAK TANK

A=3/N/PE~380-400V 50-60Hz, D=3/PE~200-210V 50-60Hz, F=2/PE~220-240V 50-60Hz, G=3/N/PE~415V 50-60Hz,
H=3/PE~220-230V 50-60Hz, K=3/PE~380-400V 50-60Hz, L=3/PE~415V 50-60Hz, M=3/PE~440V 60Hz, P=1/N/PE~220-
230V 50-60Hz, R=2/PE~220-240V 50-60Hz, U=1/N/PE~240V 50-60Hz, V=3/PE~240V 50-60Hz, W=1/N/PE~100-110V
50-60Hz

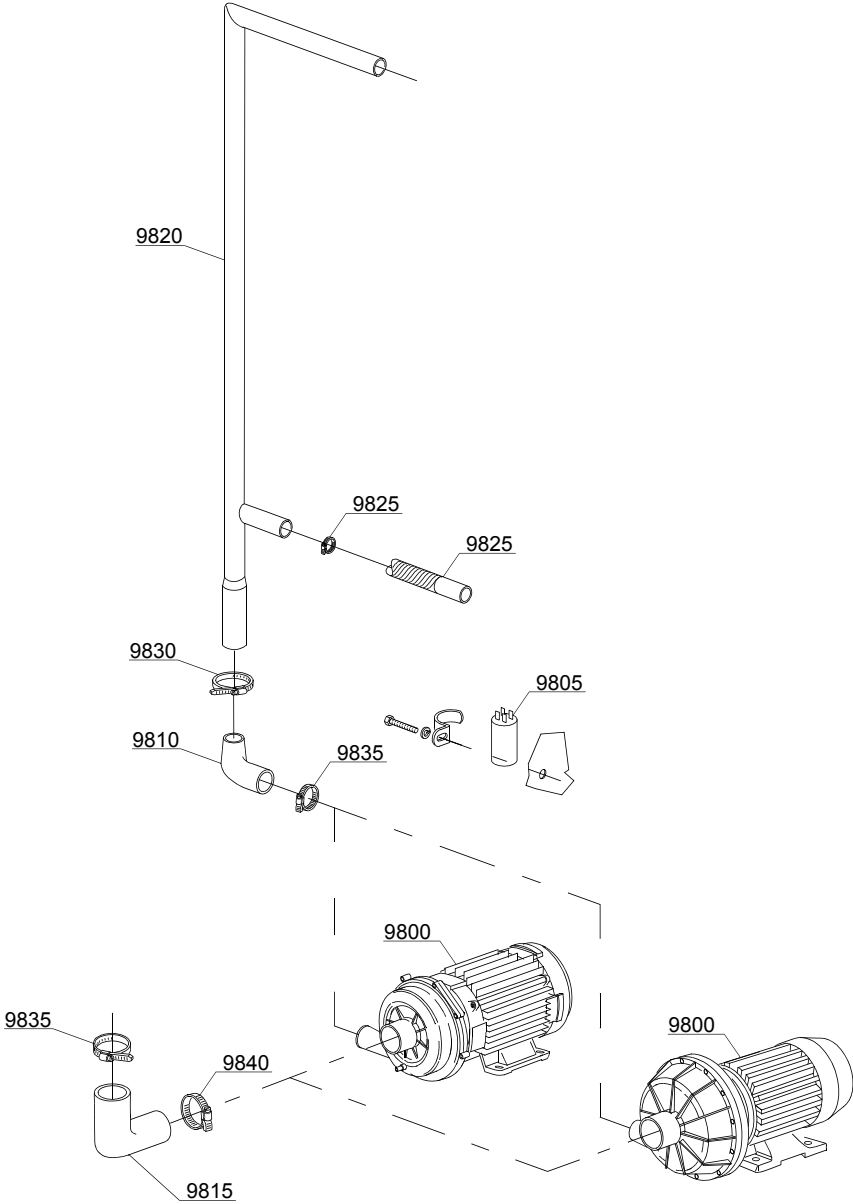

13_108_e

Spare parts

ID	P-code	SN from	SN to	Mod.	Acces.	Volt	Description
Module: Wash pump							
9800	22037		-	uw		A,F,G,H,K,L,P,R,U,V	pump 2Hp/1,5kW 50Hz
9800	22037/3		-	uw		A,F,G,H,K,L,P,R,U,V	pump - 2Hp/1,5kW 60Hz
9810	16170/M		-	uw			Delivery side pipe coupling
9815	15032/A		-	uw			Suction pipe coupling
9820	23203		-	uw			Wash ramp
9825	15033/A		-	uw			Lower delivery wash pipe
9830	11809		-	uw			30/45 clamp (minimum 2 pieces)
9835	11824		-	uw			50/70 clamp (minimum 2 pieces)
9840	2902491		-	uw			60-80 clamp (minimum 2 pieces)

em=ELECTROMECHANICAL SWITCHES, mc=SIMPLE BODY VERSION, uw=LOWER AND UPPER VERSION
16U=16U

bp=BOOSTER PUMP, dvgw=DVGW, dd=DETERGENT DISPENCER, dp=DRAIN PUMP, bt=BREAK TANK

A=3/N/PE~380-400V 50-60Hz, D=3/PE~200-210V 50-60Hz, F=2/PE~220-240V 50-60Hz, G=3/N/PE~415V 50-60Hz,
H=3/PE~220-230V 50-60Hz, K=3/PE~380-400V 50-60Hz, L=3/PE~415V 50-60Hz, M=3/PE~440V 60Hz, P=1/N/PE~220-
230V 50-60Hz, R=2/PE~220-240V 50-60Hz, U=1/N/PE~240V 50-60Hz, V=3/PE~240V 50-60Hz, W=1/N/PE~100-110V
50-60Hz

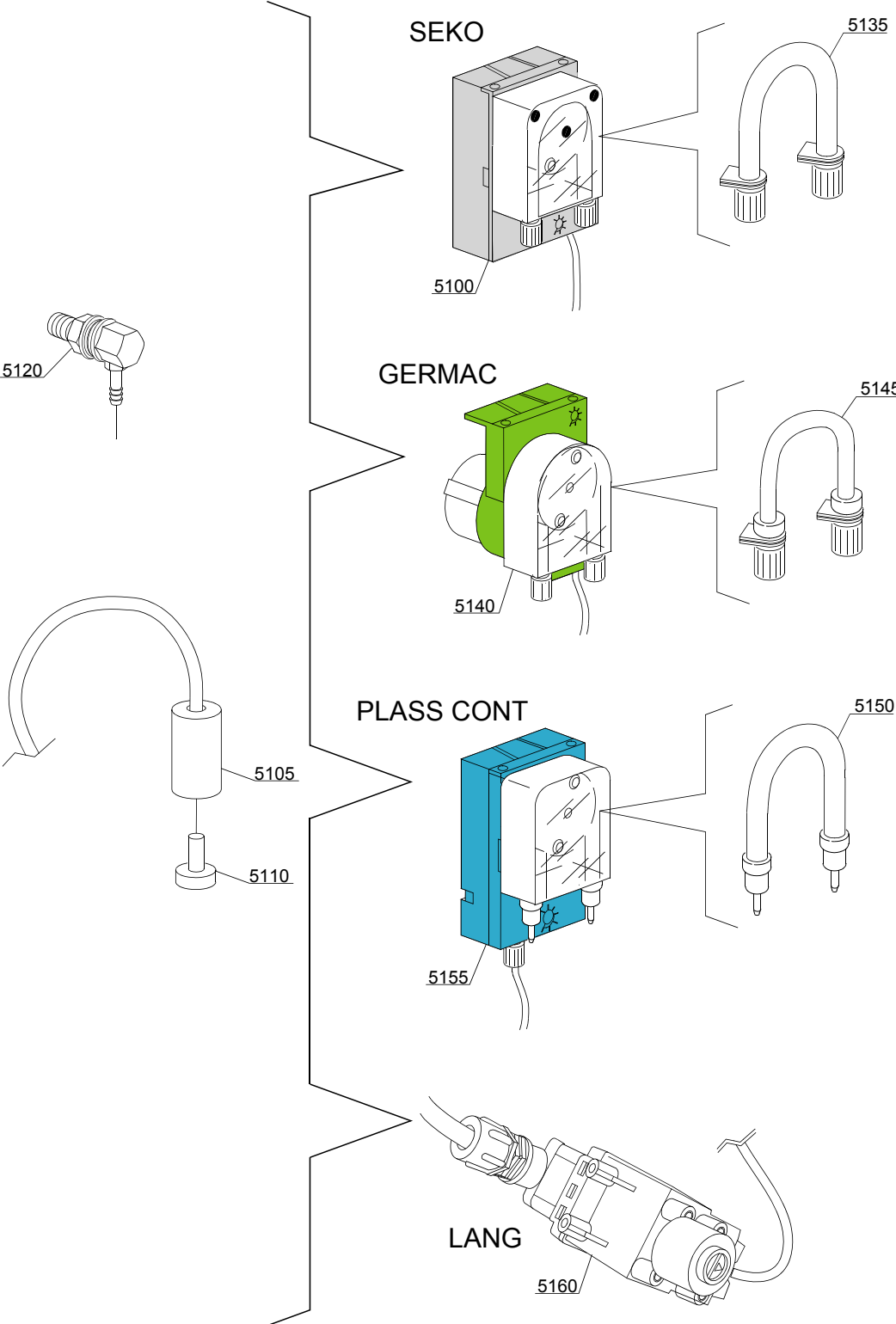

14_004_e

Spare parts

ID	P-code	SN from	SN to	Mod.	Acces.	Volt	Description
Module:Dosing detergent group							
5100	15985		-		dd		Seko detergent pump
5105	12525		-		dd		Counter-weight
5110	15058		-		dd		Suction filter (minimum 3 pieces)
5120	15123		-		dd		Steel injector
5125	15159		-		dd		OR O-ring (minimum 2 pieces)
5130	10200205		-		dd		Nut m12x1 (minimum 2 pieces)
5135	15185		-		dd		Ø 10 Seko thermoplastic pipe
5140	15985		-		dd		Germac detergent pump
5145	15108/E		-		dd		Ø 8 Germac thermoplastic pipe
5150	15985/A		-		dd		Ø 10 PLAS CONT thermoplastic pipe
5155	15985		-		dd		PLAS CONT detergent pump
5160	15108/L		-		dd		LANG detergent pump

em=ELECTROMECHANICAL SWITCHES, mc=SIMPLE BODY VERSION, uw=LOWER AND UPPER VERSION
16U=16U

bp=BOOSTER PUMP, dvgw=DVGW, dd=DETERGENT DISPENCER, dp=DRAIN PUMP, bt=BREAK TANK

A=3/N/PE~380-400V 50-60Hz, D=3/PE~200-210V 50-60Hz, F=2/PE~220-240V 50-60Hz, G=3/N/PE~415V 50-60Hz,
H=3/PE~220-230V 50-60Hz, K=3/PE~380-400V 50-60Hz, L=3/PE~415V 50-60Hz, M=3/PE~440V 60Hz, P=1/N/PE~220-
230V 50-60Hz, R=2/PE~220-240V 50-60Hz, U=1/N/PE~240V 50-60Hz, V=3/PE~240V 50-60Hz, W=1/N/PE~100-110V
50-60Hz

15_003_e

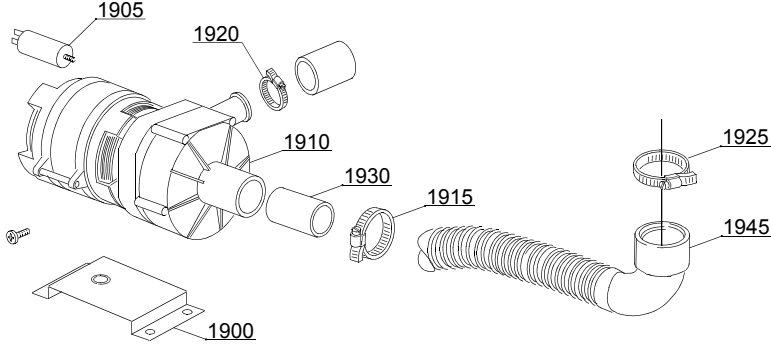

Spare parts

ID	P-code	SN from	SN to	Mod.	Acces.	Volt	Description
Module: Drain pump group							
1905	10702		-		dp		5 uF condenser
1910	10501/A		-		dp	A,F,G,H,K,L,P,R, U,V	Drain pump 0,10Hp/190W 230V 50Hz
1915	11806		-		dp		25/40 clamp (minimum 2 pieces)
1920	11836		-		dp		20/32 clamp (minimum 2 pieces)
1925	11809		-		dp		30/45 clamp (minimum 2 pieces)
1930	18044		-		dp		Ø28 top wash pipe
1935	10200039		-		dp		Flow drain filter
1945	18767		-		dp		Drain coude/pump connection pipe

em=ELECTROMECHANICAL SWITCHES, mc=SIMPLE BODY VERSION, uw=LOWER AND UPPER VERSION
16U=16U

bp=BOOSTER PUMP, dvgw=DVGW, dd=DETERGENT DISPENCER, dp=DRAIN PUMP, bt=BREAK TANK

A=3/N/PE~380-400V 50-60Hz, D=3/PE~200-210V 50-60Hz, F=2/PE~220-240V 50-60Hz, G=3/N/PE~415V 50-60Hz,
H=3/PE~220-230V 50-60Hz, K=3/PE~380-400V 50-60Hz, L=3/PE~415V 50-60Hz, M=3/PE~440V 60Hz, P=1/N/PE~220-
230V 50-60Hz, R=2/PE~220-240V 50-60Hz, U=1/N/PE~240V 50-60Hz, V=3/PE~240V 50-60Hz, W=1/N/PE~100-110V
50-60Hz

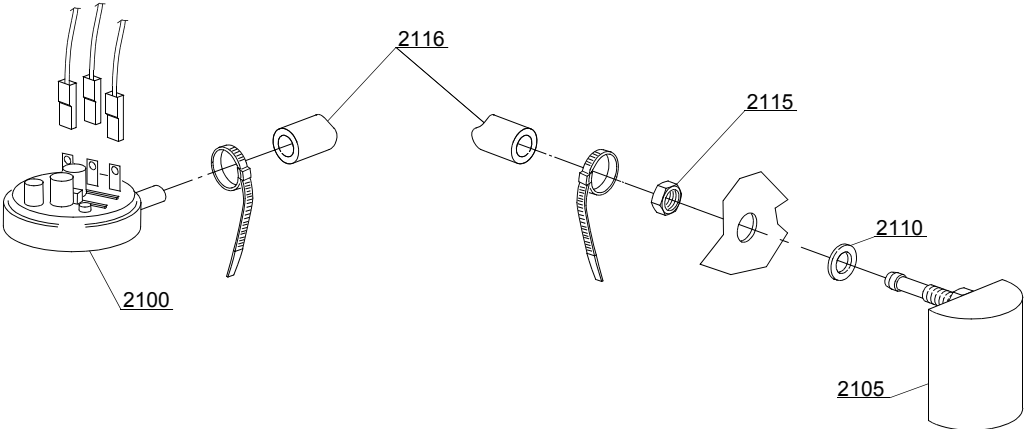

16_001_e

Spare parts

ID	P-code	SN from	SN to	Mod.	Acces.	Volt	Description
Module:Pressure switch group with air trap							
2100	75950		-	mc			Pressure switch
2105	135911/C		-	mc			Air trap
2110	13301		-				Gasket 14x8x1,5 (minimum 10 pieces)
2115	11702		-				Nut M8 (minimum 10 pieces)

em=ELECTROMECHANICAL SWITCHES, mc=SIMPLE BODY VERSION, uw=LOWER AND UPPER VERSION

16U=16U

bp=BOOSTER PUMP, dvgw=DVGW, dd=DETERGENT DISPENCER, dp=DRAIN PUMP, bt=BREAK TANK

A=3/N/PE~380-400V 50-60Hz, D=3/PE~200-210V 50-60Hz, F=2/PE~220-240V 50-60Hz, G=3/N/PE~415V 50-60Hz, H=3/PE~220-230V 50-60Hz, K=3/PE~380-400V 50-60Hz, L=3/PE~415V 50-60Hz, M=3/PE~440V 60Hz, P=1/N/PE~220-230V 50-60Hz, R=2/PE~220-240V 50-60Hz, U=1/N/PE~240V 50-60Hz, V=3/PE~240V 50-60Hz, W=1/N/PE~100-110V 50-60Hz

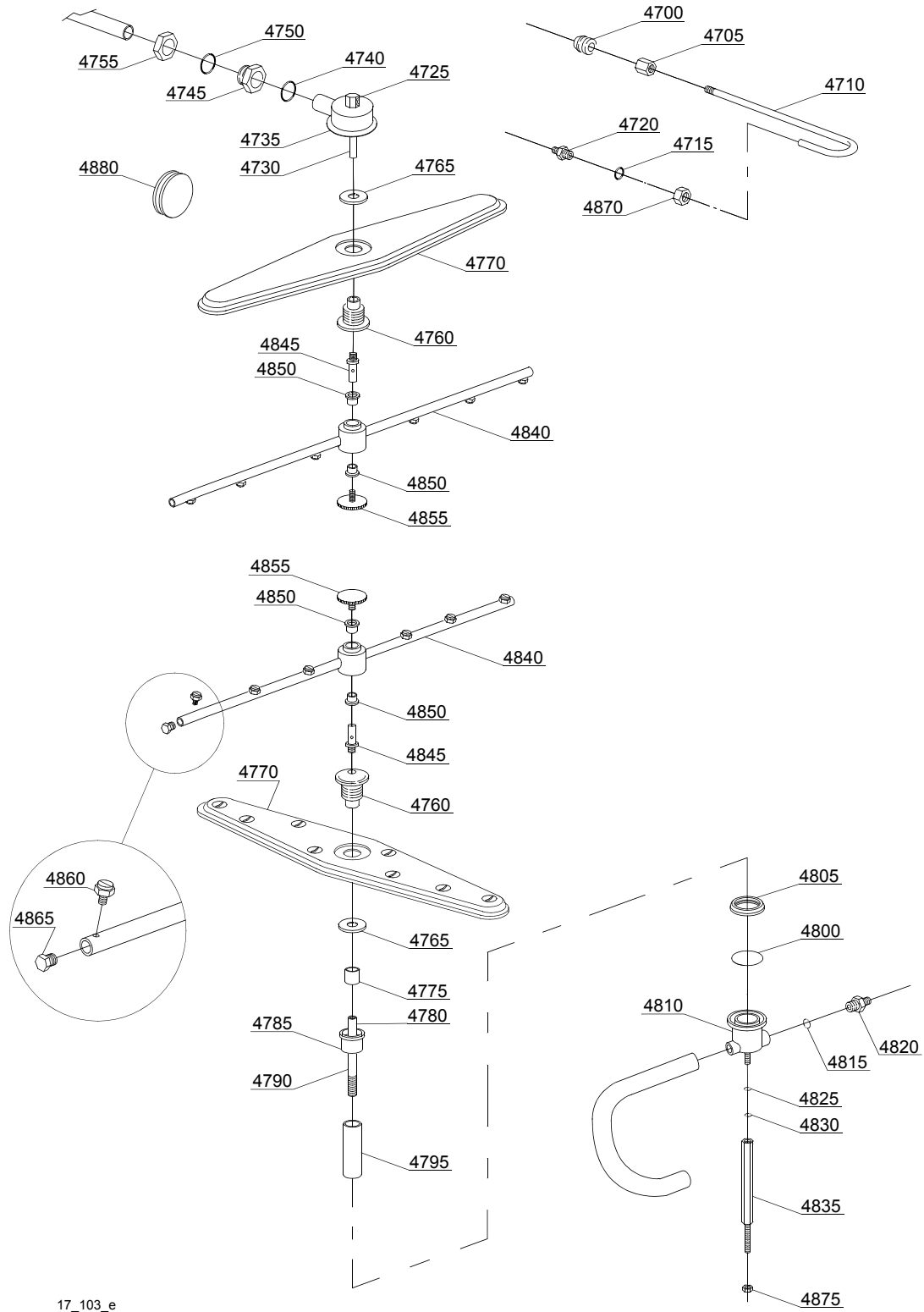

17_103_e

Spare parts

ID	P-code	SN from	SN to	Mod.	Acces.	Volt	Description
Module:Turret group with rotating arms							
4700	13304		-				Pipe-pass O-ring
4705	12526		-				Stainless steel nut coupling
4710	75066		-				Top rinse pipe
4715	13003		-				OR 112 NBR O-ring (minimum 10 pieces)
4720	12006		-				Ø10 rinse pipe fitting
4725	75319		-				Rinse elbow
4730	75322		-				Top rinse axle
4735	75067		-				Stainless steel turret
4740	13004		-				OR 3137 NBR O-ring (minimum 3 pieces)
4745	15042		-				1" 1/4 ring nut
4750	13008		-				OR 147 NBR O-ring (minimum 5 pieces)
4755	15042/A		-				Nut
4760	75320		-				Wash arm bearing
4765	75317		-				Nut for wash arm bearing
4770	75915		-				Stainless steel wash rotor
4775	75321		-				Spacer for hub
4780	75315		-				Rinse axle extension
4785	15040/A		-				Lower wash bell-shape
4790	22026		-				Lower extension axle
4795	22050		-				Steel pipe coupling
4800	13022		-				OR 4150 O-ring (minimum 10 pieces)
4805	15038		-				Ring nut connection
4810	15041/A		-				Grey wash/rinse lower distributor
4815	13003		-				OR 112 NBR O-ring (minimum 10 pieces)
4820	12506		-				Ø10 rubber-holder (minimum 2 pieces)
4825	11185		-				8x16 steel plane washer (minimum 20 pieces)
4830	13313		-				8x24x2 O-ring (minimum 5 pieces)
4835	22024		-				Lower tie rod

em=ELECTROMECHANICAL SWITCHES, mc=SIMPLE BODY VERSION, uw=LOWER AND UPPER VERSION
16U=16U

bp=BOOSTER PUMP, dvgw=DVGW, dd=DETERGENT DISPENCER, dp=DRAIN PUMP, bt=BREAK TANK

A=3/N/PE~380-400V 50-60Hz, D=3/PE~200-210V 50-60Hz, F=2/PE~220-240V 50-60Hz, G=3/N/PE~415V 50-60Hz,
H=3/PE~220-230V 50-60Hz, K=3/PE~380-400V 50-60Hz, L=3/PE~415V 50-60Hz, M=3/PE~440V 60Hz, P=1/N/PE~220-
230V 50-60Hz, R=2/PE~220-240V 50-60Hz, U=1/N/PE~240V 50-60Hz, V=3/PE~240V 50-60Hz, W=1/N/PE~100-110V
50-60Hz

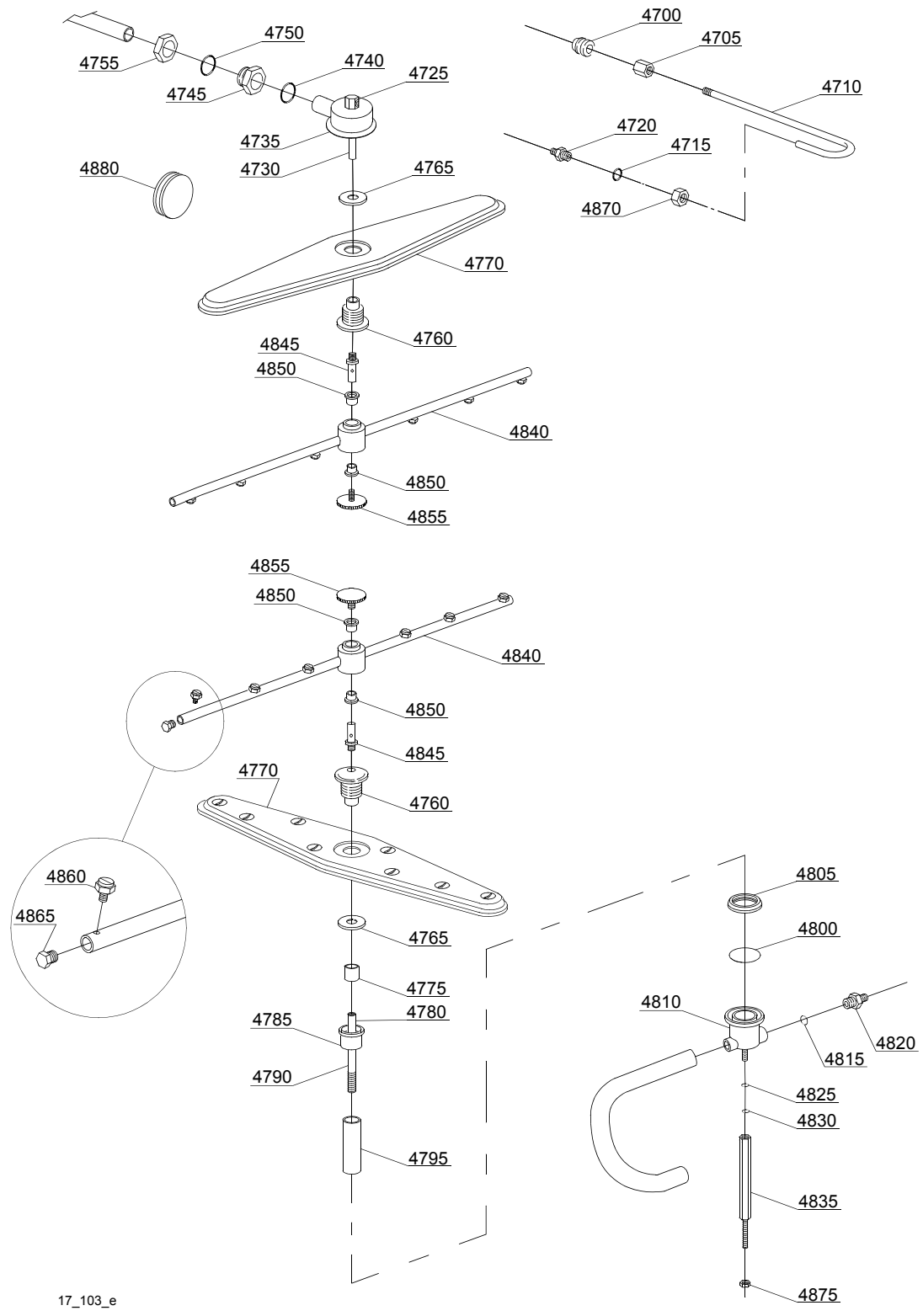

17_103_e

Spare parts

ID	P-code	SN from	SN to	Mod.	Acces.	Volt	Description
Module:Turret group with rotating arms							
4840	75918		-				Top/lower rinse arm complete
4845	75323		-				Rinse axle
4850	13330		-				Sliding washer (minimum 2 pieces)
4855	11101/B		-				Holder, rinse
4860	560018		-				Stainless steel rinse nozzle
4865	560017		-				Rinse arm plug
4870	12006/A		-				Ø10 pipe fitting 3/8x3,5 nut 19 hexagonal
4875	11702		-				Nut M8 (minimum 10 pieces)
4880	13316/A		-				DVGW hole O-ring

em=ELECTROMECHANICAL SWITCHES, mc=SIMPLE BODY VERSION, uw=LOWER AND UPPER VERSION
16U=16U

bp=BOOSTER PUMP, dvgw=DVGW, dd=DETERGENT DISPENCER, dp=DRAIN PUMP, bt=BREAK TANK

A=3/N/PE~380-400V 50-60Hz, D=3/PE~200-210V 50-60Hz, F=2/PE~220-240V 50-60Hz, G=3/N/PE~415V 50-60Hz,
H=3/PE~220-230V 50-60Hz, K=3/PE~380-400V 50-60Hz, L=3/PE~415V 50-60Hz, M=3/PE~440V 60Hz, P=1/N/PE~220-
230V 50-60Hz, R=2/PE~220-240V 50-60Hz, U=1/N/PE~240V 50-60Hz, V=3/PE~240V 50-60Hz, W=1/N/PE~100-110V
50-60Hz

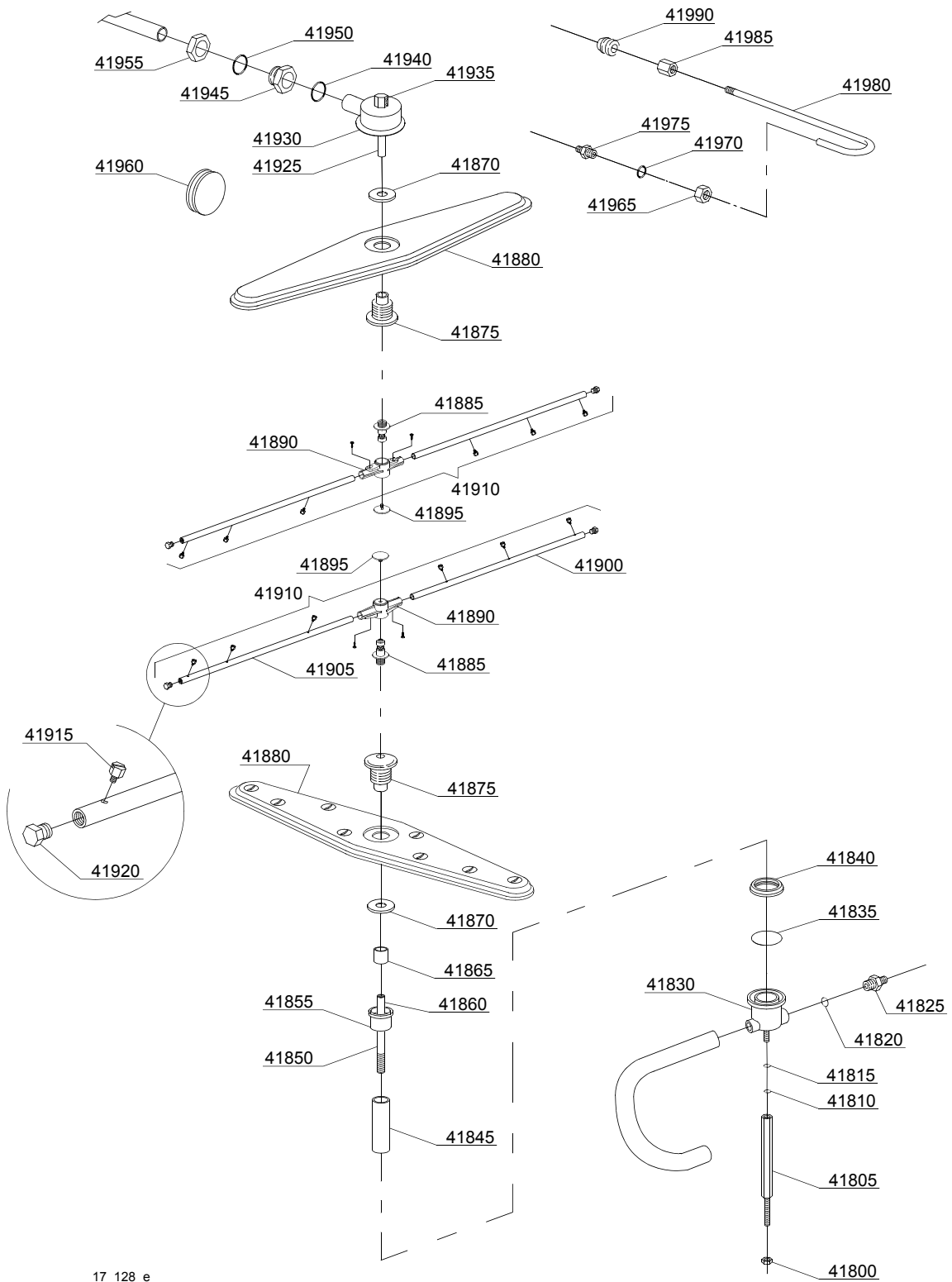

17_128_e

Spare parts

ID	P-code	SN from	SN to	Mod.	Acces.	Volt	Description
Module:Turret group with rotating arms							
41800	11702		-				M8 stainless steel nut (minimum 10 pieces)
41805	22024		-				Lower tie rod
41810	13313		-				8x24x2 O-ring (minimum 5 pieces)
41815	11185		-				8x16 steel plane washer (minimum 20 pieces)
41820	13003		-				OR 112 NBR O-ring (minimum 10 pieces)
41825	12506		-				Ø10 rubber-holder (minimum 2 pieces)
41830	15041/A		-				Grey wash/rinse lower distributor
41835	13022		-				OR 4150 O-ring (minimum 10 pieces)
41840	15038		-				Ring nut connection
41845	22050		-				Steel pipe coupling
41850	22026		-				Lower extension axle
41855	15040/A		-				Lower wash bell-shape
41860	75315		-				Rinse axle extension
41865	75321		-				Spacer for hub
41870	75317		-				Nut for wash arm bearing
41875	75320		-				Wash arm bearing
41880	75915		-				Stainless steel wash rotor
41885	10651		-				Rinse axle
41890	10650		-				Rinse arm
41895	10652		-				Rinse arm screw
41900	10657		-				Right rinse arm - stainless steel nozzle
41905	10658		-				Left rinse arm - stainless steel nozzle
41910	75918		-				Top/lower rinse arm complete
41915	560018		-				Stainless steel rinse nozzle
41920	560017		-				Rinse arm plug
41925	75322		-				Top rinse axle
41930	75067		-				Stainless steel turret
41935	75319		-				Rinse elbow

em=ELECTROMECHANICAL SWITCHES, mc=SIMPLE BODY VERSION, uw=LOWER AND UPPER VERSION
16U=16U

bp=BOOSTER PUMP, dvgw=DVGW, dd=DETERGENT DISPENCER, dp=DRAIN PUMP, bt=BREAK TANK

A=3/N/PE~380-400V 50-60Hz, D=3/PE~200-210V 50-60Hz, F=2/PE~220-240V 50-60Hz, G=3/N/PE~415V 50-60Hz,
H=3/PE~220-230V 50-60Hz, K=3/PE~380-400V 50-60Hz, L=3/PE~415V 50-60Hz, M=3/PE~440V 60Hz, P=1/N/PE~220-
230V 50-60Hz, R=2/PE~220-240V 50-60Hz, U=1/N/PE~240V 50-60Hz, V=3/PE~240V 50-60Hz, W=1/N/PE~100-110V
50-60Hz

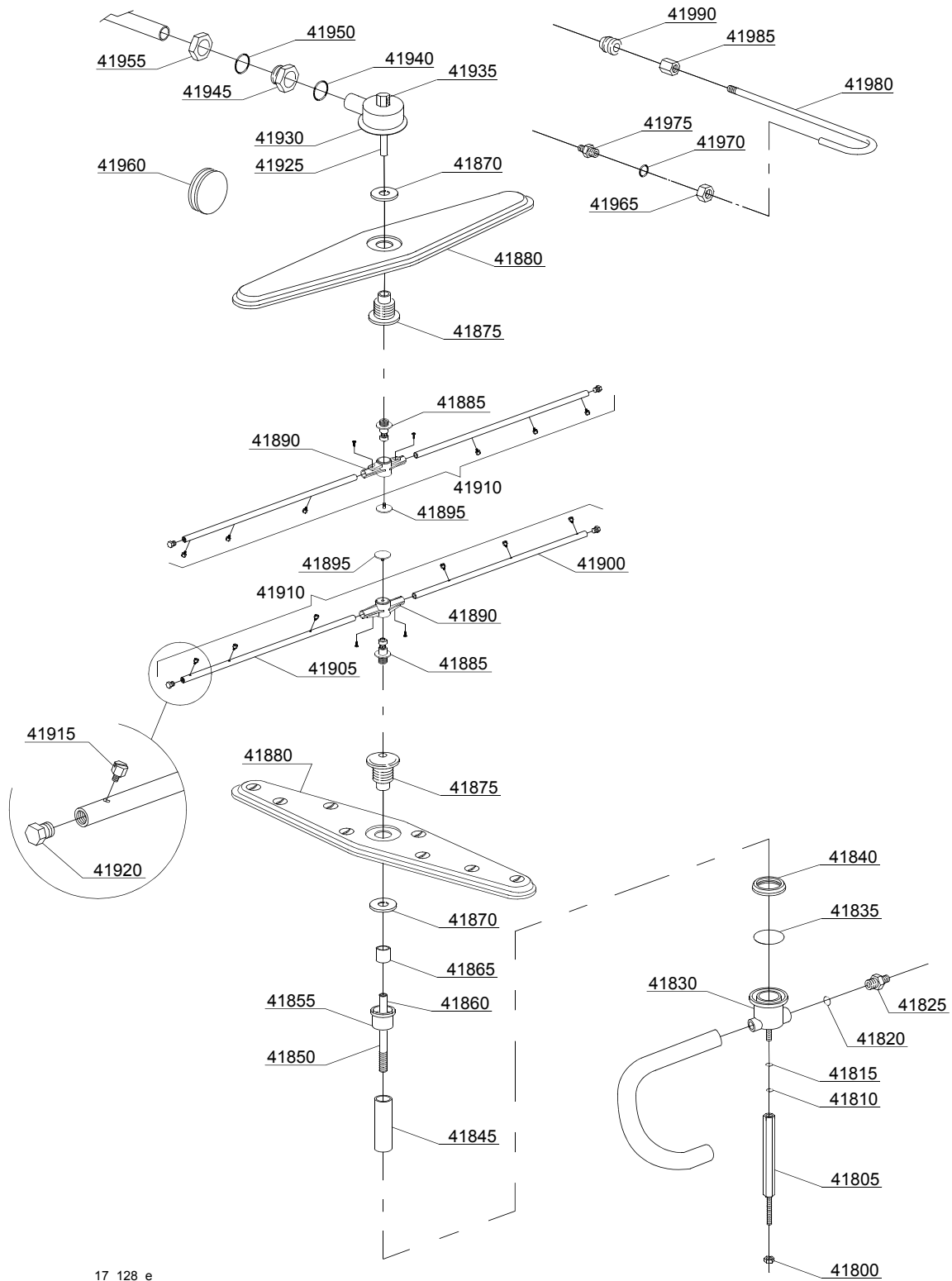

17_128_e

Spare parts

ID	P-code	SN from	SN to	Mod.	Acces.	Volt	Description
Module:Turret group with rotating arms							
41940	13004		-				OR 3137 NBR O-ring (minimum 3 pieces)
41945	15042		-				1" 1/4 ring nut
41950	13008		-				OR 147 NBR O-ring (minimum 5 pieces)
41955	11101/B		-				Stainless steel group fixing screw
41960	13316/A		-				DVGW hole O-ring
41965	12006/A		-				Ø10 pipe fitting 3/8x3,5 nut 19 hexagonal
41970	13003		-				OR 112 NBR O-ring (minimum 10 pieces)
41975	12006		-				Ø10 rinse pipe fitting
41980	75066		-				Top rinse pipe
41985	12526		-				Stainless steel nut coupling
41990	13304		-				Pipe-pass O-ring

em=ELECTROMECHANICAL SWITCHES, mc=SIMPLE BODY VERSION, uw=LOWER AND UPPER VERSION
16U=16U

bp=BOOSTER PUMP, dvgw=DVGW, dd=DETERGENT DISPENCER, dp=DRAIN PUMP, bt=BREAK TANK

A=3/N/PE~380-400V 50-60Hz, D=3/PE~200-210V 50-60Hz, F=2/PE~220-240V 50-60Hz, G=3/N/PE~415V 50-60Hz,
H=3/PE~220-230V 50-60Hz, K=3/PE~380-400V 50-60Hz, L=3/PE~415V 50-60Hz, M=3/PE~440V 60Hz, P=1/N/PE~220-
230V 50-60Hz, R=2/PE~220-240V 50-60Hz, U=1/N/PE~240V 50-60Hz, V=3/PE~240V 50-60Hz, W=1/N/PE~100-110V
50-60Hz