



ISO 9001  
BUREAU VERITAS  
Certification



ISO 14001  
BUREAU VERITAS  
Certification



**Applus®**  
LGA1  
Organismo  
Notificado  
**0370**

**AENOR**  
Organismo  
Notificado  
**0099**

FUNDADA EN 1876  
**MASBAGA**  
GRANDES COCINAS

**EURAST**

**mac-fin**

TOLERANCIAS GENERALES: ±0.5 mm

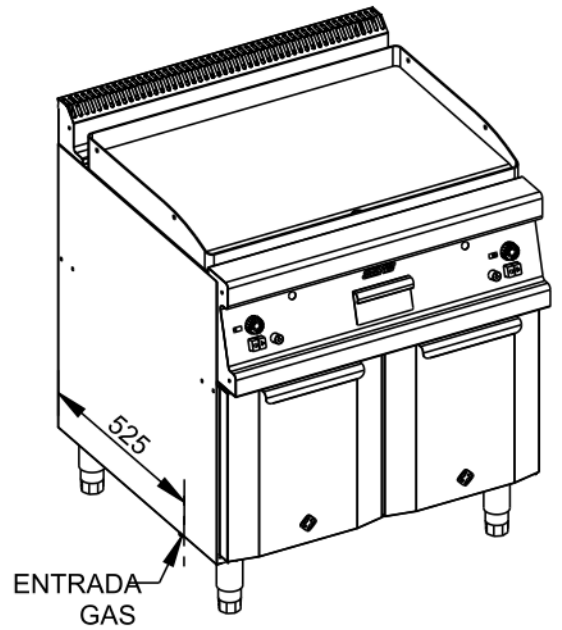
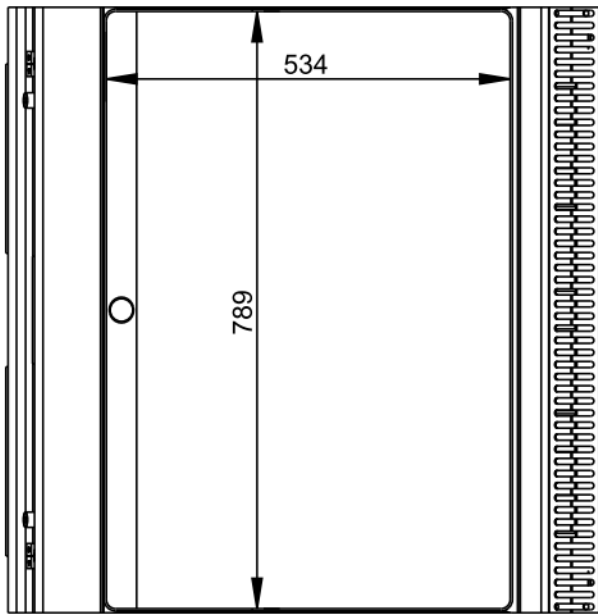
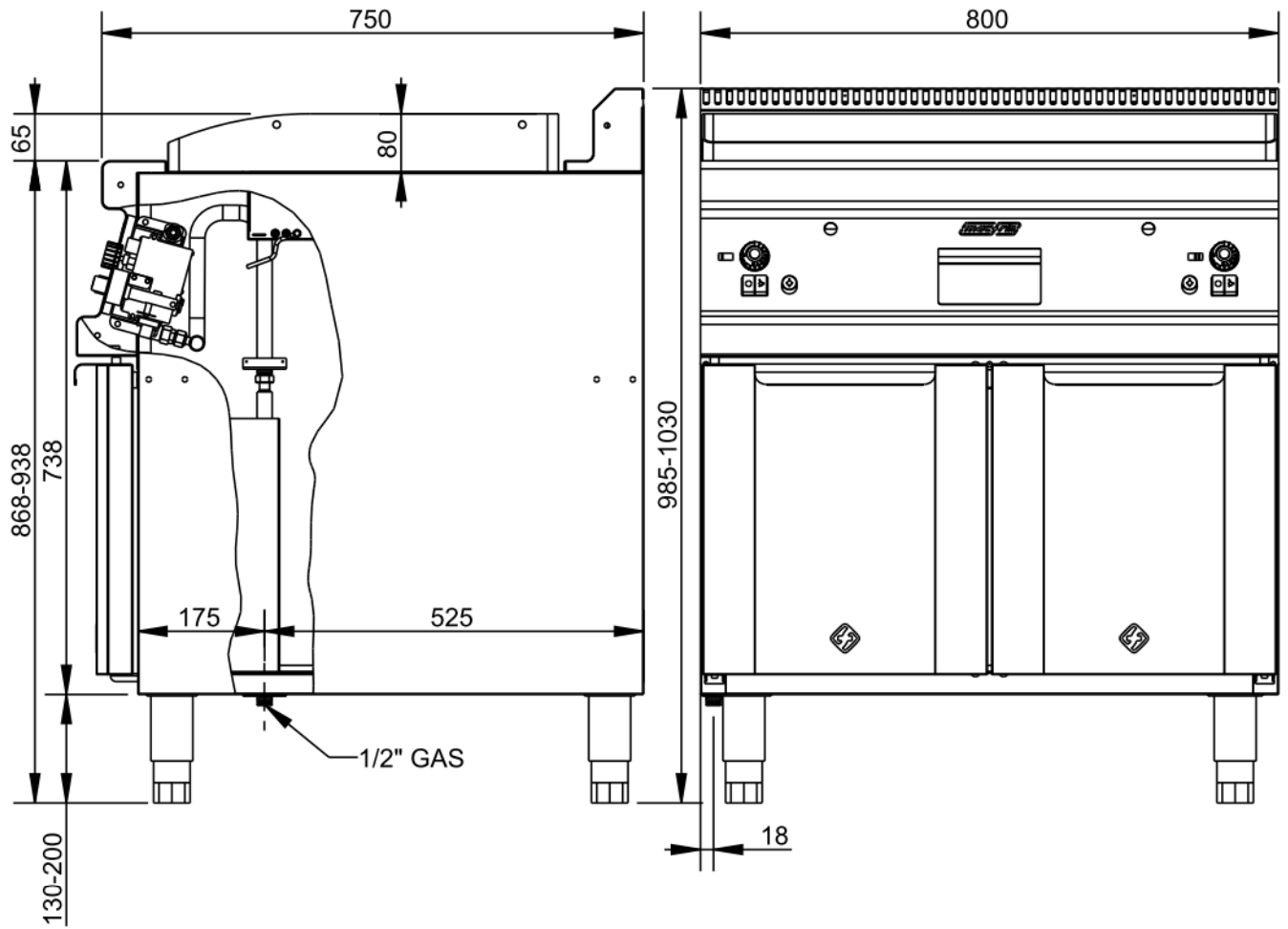

FAMILIA: COCINAS 2008

FECHA: 16/09/11

MODELO: 3607

PESO(Kg): 100.023

DENOMINACION:  
FRYTOP Fe 800X750 GAS

ESCALA:  
1/10

MATERIAL:  
INOX

CODIGO:  
3607



**Applus®**  
LGA1  
Organismo  
Notificado  
**0370**

**AENOR**  
Organismo  
Notificado  
**0099**



TOLERANCIAS GENERALES: ±0.5 mm

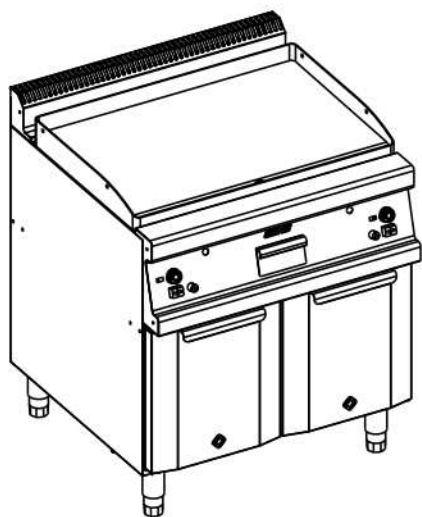

QT	COD	DESCRIPCION
1	350563	BASE 800 X 750
1	300385PC	BATERIA COMPLETA 2 VALVULAS 800
1	350485PC	BATERIA COMPLETA ARMARIO
2	350503	BISAGRA
2	350505M	CONJ.PUERTA COCINA DCHA/IZQ.
1	362149C	CONJUNTO CUBETA / CAJON FT
1	362439C	CONJUNTO FRONTAL FT.GAS 800
1	340122C	CONJUNTO PETO 800
1	362416M	DEFLECTOR MONTADO 800X750
2	3739	ENCENDIDO PIEZOELECTRICO
1	350565	FRONTAL INFERIOR 800
2	6084	IMAN
1	A1006099	JUNTA PLANA 1/2 GOMA
1	350508	LATERAL DERECHO 750
1	350509	LATERAL IZQUIERDO 750
2	350104	OMEGA COCINA 800
4	C6260511	PATA INOX 130-200 (S_F)
1	305306P	PLANCHA Fe LISA 795X540
1	300133	RAMPA CAÍDA ACEITE
2	362476	SOPORTE VALV.MINISIT-CONTACTOR
1	350599	TAPA TUBOS ENTRADA GAS
1	330213	TRASERO 800
2	T10030	TUBO AL D.10 L.300
2	3103M	VALVULA SIT COMPLETA

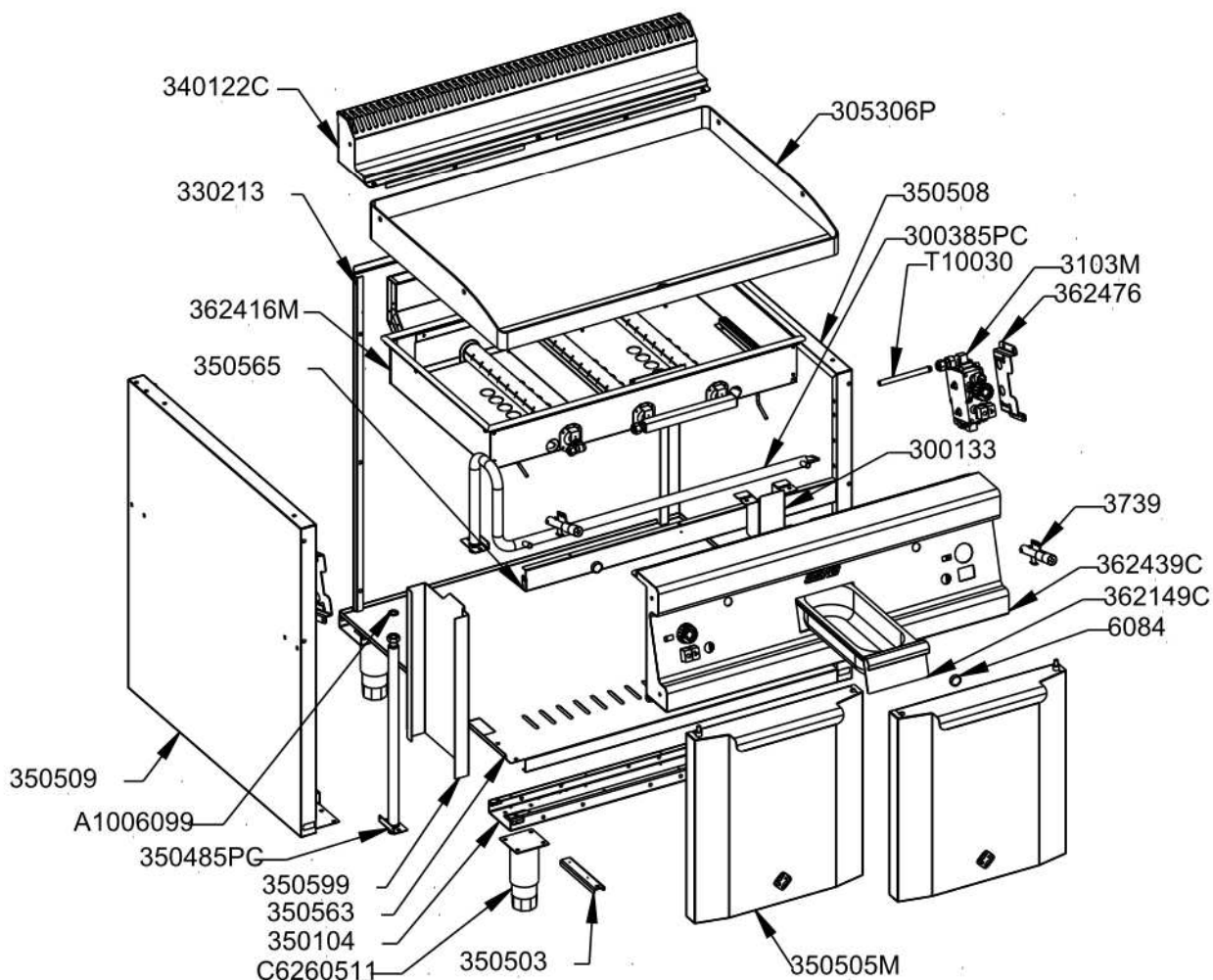

FAMILIA: COCINAS 2008

FECHA: 16/09/11

MODELO: 3607

PESO(Kg): 100.023

DENOMINACION:  
FRYTOP Fe 800X750 GAS

ESCALA:  
1/15

MATERIAL:  
INOX

CODIGO:  
3607



**Applus®**  
LGA1  
Organismo  
Notificado  
**0370**

**AENOR**  
Organismo  
Notificado  
**0099**



TOLERANCIAS GENERALES: ±0.5 mm

QT	COD	DESCRIPCION	FAB.	MATERIAL	DATA	PESO
8	TESTA35	ANGULO TESTATINA 35	SÍ	INOX 0.6	29/08/07	0.004
4	TESTA70	ANGULO TESTATINA 70	SÍ	INOX 0.6	29/08/07	0.008
2	TESTA140	ANGULO TESTATINA 140	SÍ	INOX 0.6	29/08/07	0.016
1	350563	BASE 800 X 750	SÍ	INOFER 0.8	21/12/09	3.698
2	350503	BISAGRA	SÍ	INOFER 1.2	20/09/07	0.067
1	362426	BUR.CERAM.800X600/750-C6580179	SÍ	FIBRA	09/01/09	0.260
2	350505M	CONJ.PUERTA COCINA DCHA/IZQ.	SÍ	INOX	26/05/08	3.467
1	362149C	CONJUNTO CUBETA / CAJON FT	SÍ	INOX	27/06/08	0.775
1	362439C	CONJUNTO FRONTAL FT.GAS 800	SÍ	INOX	23/10/09	4.641
1	340122C	CONJUNTO PETO 800	SÍ	INOX	16/09/08	1.892
2	350518	CONTRAPUERTA ARMARIO COCINA	SÍ	INOFER 1.2	25/02/10	1.975
1	300388	CORRELLAMAS	SÍ	INOFER 0.8	05/02/09	0.106
1	362416	DEFLECTOR FRYTOP 800X750/600	SÍ	INOFER 0.8	28/09/10	2.951
1	362416M	DEFLECTOR MONTADO 800X750	SÍ	INOX	06/05/09	7.454
1	350565	FRONTAL INFERIOR 800	SÍ	INOFER 0.8	15/06/10	0.394
1	362439	FRONTAL MANDOS FRYTOP 800	SÍ	INOX 1.2	02/05/11	3.999
1	362148	GUIA CAJON FT(GN 2/8-65)	SÍ	INOFER 0.8	24/10/08	0.280
1	350508	LATERAL DERECHO 750	SÍ	INOFER 0.8	27/02/09	4.447
1	350509	LATERAL IZQUIERDO 750	SÍ	INOFER 0.8	27/02/09	4.447
2	350104	OMEGA COCINA 800	SÍ	GALVA 1.5	13/11/08	1.495
1	340122	PETO SOBRE 800X750/900	SÍ	INOX 1.2	07/04/08	1.597
2	330294	PLETINA BASE BATERÍA	SÍ	FE 1.5	03/11/08	0.021
2	490133	PROTECTOR BULBO	SÍ	INOFER 0.8	14/03/08	0.060
2	350505	PUERTA ARMARIO COCINA	SÍ	INOX 0.8	01/10/07	1.470
1	300133	RAMPA CAÍDA ACEITE	SÍ	INOFER 0.8	18/07/08	0.118
1	362452	SALIDA VAHOS FT800	SÍ	GALVA 0.8	01/04/09	1.721
1	362410	SEPARADOR QUEM.750-600	SÍ	INOFER 1.2	05/05/09	0.454
1	3621491	SOPORTE TIRADOR CAJON FT	SÍ	INOFER 1.2	27/06/08	0.058
2	362476	SOPORTE VALV.MINISIT-CONTACTOR	SÍ	GALVA 1.5	24/09/08	0.122
2	362176	SOPORTE-ADAPT.PIEZO SIT-JUNK	SÍ	INOFER 0.8	18/05/11	0.035
1	301399	TAPA 20X20	SÍ	FE 1.2	02/09/08	0.004
1	300399	TAPA 20X20 C/AGUJERO D.12	SÍ	FE 1.2	02/09/08	0.003
1	350599	TAPA TUBOS ENTRADA GAS	SÍ	INOFER 0.8	22/10/08	0.657
1	340179	TAPETA IZQ. PETO 750/900	SÍ	INOFER 1.2	30/11/07	0.135
1	340178	TAPETA DERECHA PETO 750/900	SÍ	INOFER 1.2	30/11/07	0.135
2	362478	TAPETA LATERAL DEFLECTOR	SÍ	GALVA 0.8	01/04/09	0.046
1	350178	TAPETA LATERAL DERECHA FRONTAL	SÍ	INOX 1.2	26/06/07	0.109
1	350179	TAPETA LATERAL IZQUIEDA FRONTAL	SÍ	INOX 1.2	26/06/07	0.109
1	362149	TIRADOR CAJON FT (GN2/8-65)	SÍ	INOX 1.2	19/11/07	0.162
1	330213	TRASERO 800	SÍ	INOFER 0.8	07/01/09	4.103
1	350485P	BATERIA ARMARIO COCINA	NO	FE 1/2"	14/11/08	0.211
1	300385PC	BATERIA COMPLETA 2 VALVULAS 800	NO	FE ZINCADO	13/01/09	0.916
1	350485PC	BATERIA COMPLETA ARMARIO	NO	FE ZN	14/11/08	0.254
1	300385P	BATERÍA 2 VALVULAS 800	NO	FE 1/2"	13/01/09	0.884



FAMILIA: COCINAS 2008

FECHA: 16/09/11

MODELO: 3607

PESO(Kg): 100.023

DENOMINACION:  
FRYTOP Fe 800X750 GAS

ESCALA:  
1/10

MATERIAL:  
INOX

CODIGO:  
3607



**Applus®**  
LGA1  
Organismo  
Notificado  
**0370**

**AENOR**  
Organismo  
Notificado  
**0099**



TOLERANCIAS GENERALES: ±0.5 mm

5	3782	BICONO D.10 LATON	NO	LATON	01/01/09	0.001
2	A1018999	BICONO PILOTO	NO	LATON	01/01/09	0.002
2	C5810139	BUJIA	NO	CER	01/01/09	0.004
2	2193	CABLE PIEZO L=370	NO	FIBRA/CU	01/01/09	0.003
4	C5810419	CODO 90° -3/8" SIT S/R.0906252	NO	AL	01/01/09	0.054
1	493086PC	COLECTOR 2 SALIDAS HGR	NO	FE ZN.	07/10/08	0.000
1	493086P	COLECTOR HGR	NO	FE	07/10/08	0.124
1	C6440489	CUBETA GN 2/8-65	NO	INOX	19/11/07	0.555
2	350503P	EJE SUPERIOR PUERTA	NO	FE.ZN	25/05/08	0.013
2	3739	ENCENDIDO PIEZOELECTRICO	NO	INOX	29/04/11	0.098
2	6084	IMAN	NO	IMAN - INOX	01/01/01	0.021
3	C5812649	INY. D.110 GLP QUEM. L.400	NO	LATON	01/01/09	0.012
3	C5812669	INY. D.160 GN QUEM.L.400	NO	LATON	01/01/09	0.012
2	C5810169	INY.PILOTO GLP (22) 1 AGUJ.	NO	LATON	01/01/09	0.002
2	C5810159	INY.PILOTO GN (27.2) 2 AGUJ.	NO	LATON	01/01/09	0.002
1	A1006099	JUNTA PLANA 1/2 GOMA	NO	GOMA	04/09/08	0.001
4	3785	JUNTA VALVULA MINISIT	NO	GOMA	01/01/09	0.000
4	362489P	MACHON D.10 - 3/8" - M16X1.5	NO	LATON	01/10/08	0.029
2	3765	MANDO VALV. SIT	NO	PLASTICO	01/01/09	0.014
1	330189	MANGUITO M16X1.5 TUBO D.10	NO	FE	22/09/08	0.007
4	C6260511	PATA INOX 130-200 (S_F)	NO	INOX	01/01/09	0.320
2	C5810129	PILOTO POLIDORO	NO	FE	01/01/09	0.053
2	C5810129M	PILOTO POLIDORO COMPLETO	NO	FE	28/01/11	0.074
1	305306P	PLANCHA Fe LISA 795X540	NO	Fe 15mm	16/09/11	52.465
1	C5815159	PORTAINYECTOR COMPLETO	NO	LATON	01/01/09	0.058
3	300187P	QUEMADOR TUBULAR D.40 L.400	NO	INOX	05/08/09	0.424
2	A1018996	RACORD BUJIA	NO	LATON	01/01/09	0.004
1	C5811459	RACORD 2P. 359GLCU-COAS 14X1/2"	NO	CU/LAT.	01/01/08	0.021
2	A1018997	RACORD PILOTO	NO	LATON	01/01/09	0.004
2	A1018998	RACORD TERMOPAR	NO	LATON	01/01/09	0.004
2	C5820049	TERMOPAR LISO M9X1 L 320	NO	CU	01/01/09	0.018
2	1050	TORNILLO ALLEN M5X12 DIN912	NO	INOX	22/05/09	0.004
4	1095	TORNILLO M-5X10 TLR INOX	NO	INOX	01/01/09	0.003
16	1051	TORNILLO ZN M4X15 DIN 84	NO	FE ZN	01/01/09	0.003
2	T10030	TUBO AL D.10 L.300	NO	AL 99.7%	13/05/09	0.031
2	362189P	TUBO COBRE 10X8 L.25	NO	CU 10X8	13/01/09	0.006
5	3781	TUERCA M16X1.5 D.10	NO	LATON	05/09/08	0.015
2	C5815359	TUERCA+BICONO D.6 M10X1	NO	LATON	01/01/09	0.006
2	3103	VALVULA MINI SIT	NO	AL	01/01/09	0.700
2	3103M	VALVULA SIT COMPLETA	NO	AL	05/09/08	0.940



FAMILIA: COCINAS 2008

FECHA: 16/09/11

MODELO: 3607

PESO(Kg): 100.023

DENOMINACION:  
FRYTOP Fe 800X750 GAS

ESCALA:  
1/10

MATERIAL:  
INOX

CODIGO:  
3607



**Applus®**  
LGA1  
Organismo Notificado  
**0370**

**AENOR**  
Organismo Notificado  
**0099**



TOLERANCIAS GENERALES:  $\pm 0.5$  mm



EN LA IMAGEN:  
PUERTA IZQ.  
CAMBIANDO LOS 4 TORNILLOS  
ENTRE SÍ, ES DERECHA.

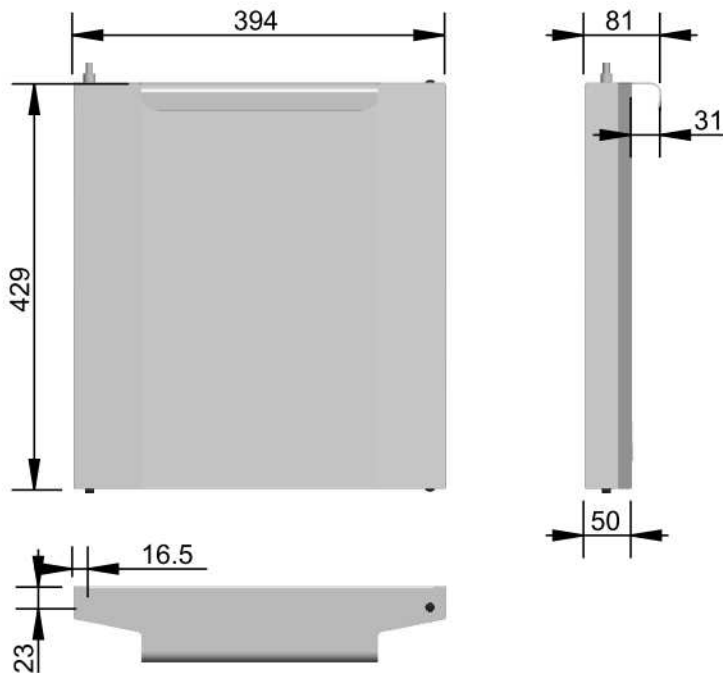

QT.	COD	DESCRIPCION
1	1050	TORNILLO ALLEN M5X12 DIN912
2	1095	TORNILLO M-5X10 TLR INOX
1	350505	PUERTA ARMARIO COCINA
1	350518	CONTRAPUERTA ARMARIO COCINA
1	350503P	EJE SUPERIOR PUERTA

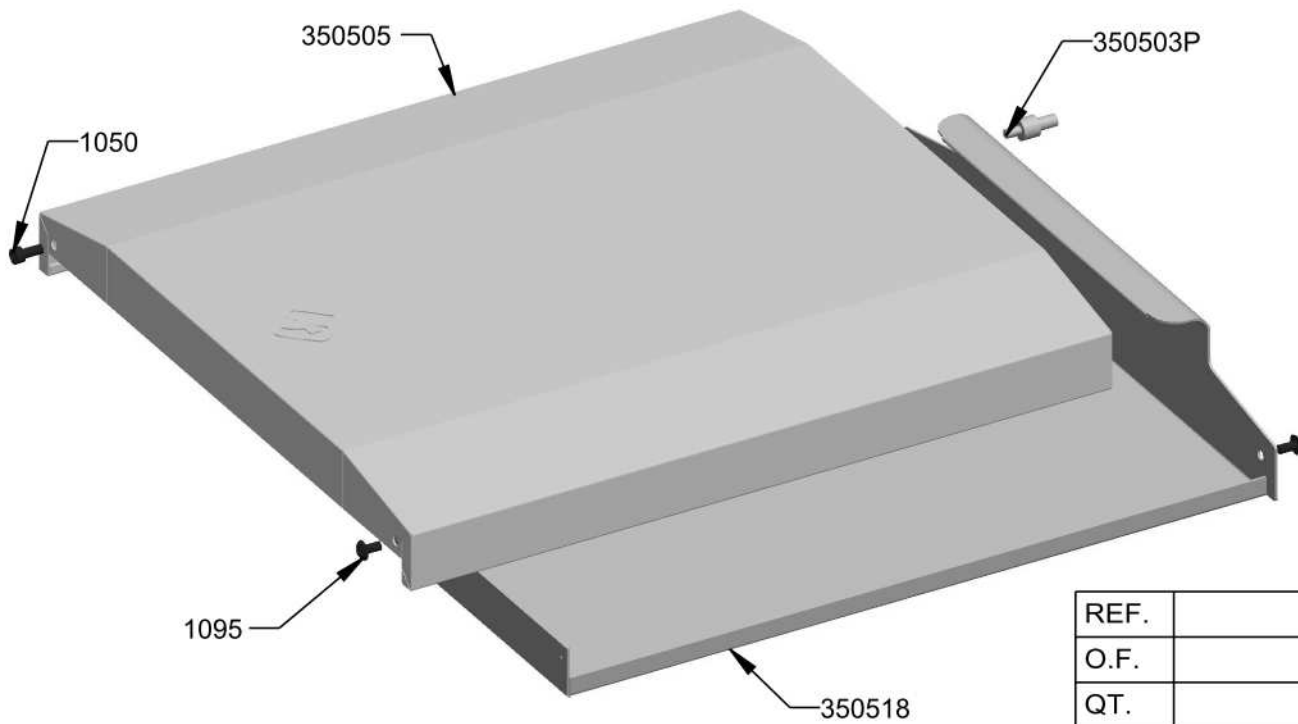

REF.	
O.F.	
QT.	
DEST.	



FAMILIA: COCINAS 2008

FECHA: 26/05/08

MODELO: 3505

PESO(Kg): 3.467

DENOMINACION:  
CONJ. PUERTA COCINA DCHA/IZQ.

ESCALA:  
1/4

MATERIAL:  
INOX

CODIGO:  
350505M



**Applus®**  
LGA1  
Organismo  
Notificado  
**0370**

**AENOR**  
Organismo  
Notificado  
**0099**



TOLERANCIAS GENERALES: ±0.5 mm

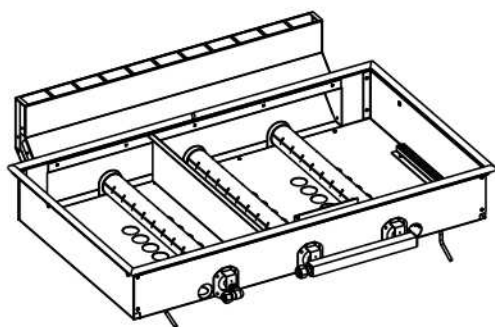

QT	COD	DESCRIPCION
1	3782	BICONO D.10 LATON
1	362426	BUR.CERAM.800X600/750-C6580179
2	2193	CABLE PIEZO L=370
1	493086PC	COLECTOR 2 SALIDAS HGR
1	300388	CORRELLAMAS
1	362416	DEFLECTOR FRYTOP 800X750/600
3	C5812649	INY. D.110 GLP QUEM. L.400
3	C5812669	INY. D.160 GN QUEM.L.400
2	C5810129M	PILOTO POLIDORO COMPLETO
1	C5815159	PORTAINYECTOR COMPLETO
2	490133	PROTECTOR BULBO
3	300187P	QUEMADOR TUBULAR D.40 L.400
1	362452	SALIDA VAHOS FT800
1	362410	SEPARADOR QUEM.750-600
2	362478	TAPETA LATERAL DEFLECTOR
2	C5820049	TERMOPAR LISO M9X1 L 320
1	3781	TUERCA M16X1.5 D.10

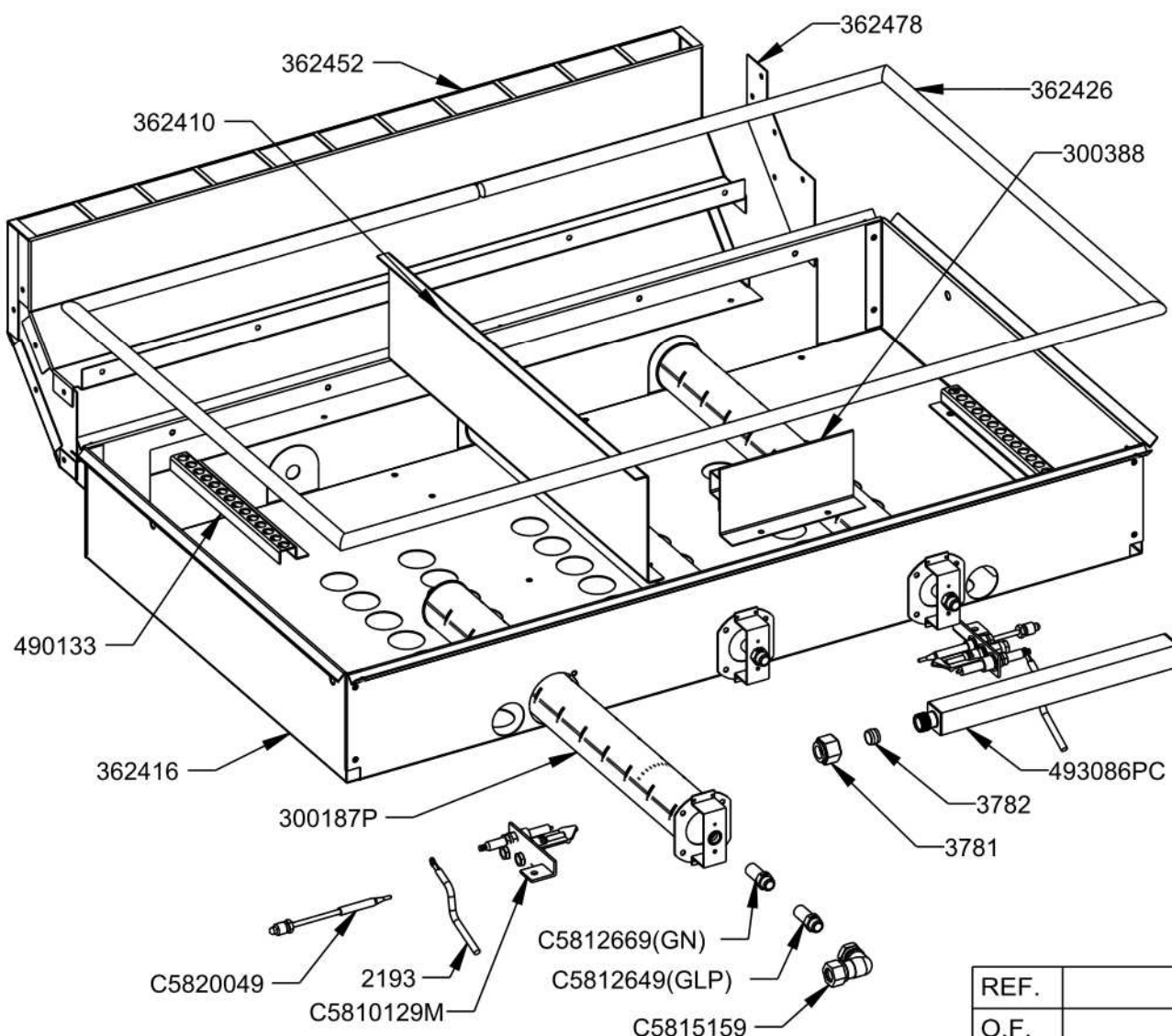

REF.	
O.F.	
QT.	
DEST.	



FAMILIA: COCINAS 2008

FECHA: 06/05/09

MODELO: 3624

PESO(Kg): 7.454

DENOMINACION:  
DEFLECTOR MONTADO 800X750

ESCALA:  
1/5

MATERIAL:  
INOX

CODIGO:  
362416M



**Applus®**  
LGA1  
Organismo  
Notificado  
**0370**

**AENOR**  
Organismo  
Notificado  
**0099**



TOLERANCIAS GENERALES: ±0.5 mm

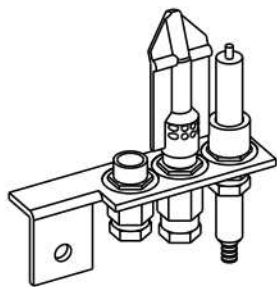

ESCALA 1/2

QT	COD	DESCRIPCION
1	A1018996	RACORD BUJIA
1	A1018997	RACORD PILOTO
1	A1018998	RACORD TERMOPAR
1	A1018999	BICONO PILOTO
1	C5810129	PILOTO POLIDORO
1	C5810139	BUJIA
1	C5810159	INY.PILOTO GN (27.2) 2 AGUJ.
1	C5810169	INY.PILOTO GLP (22) 1 AGUJ.

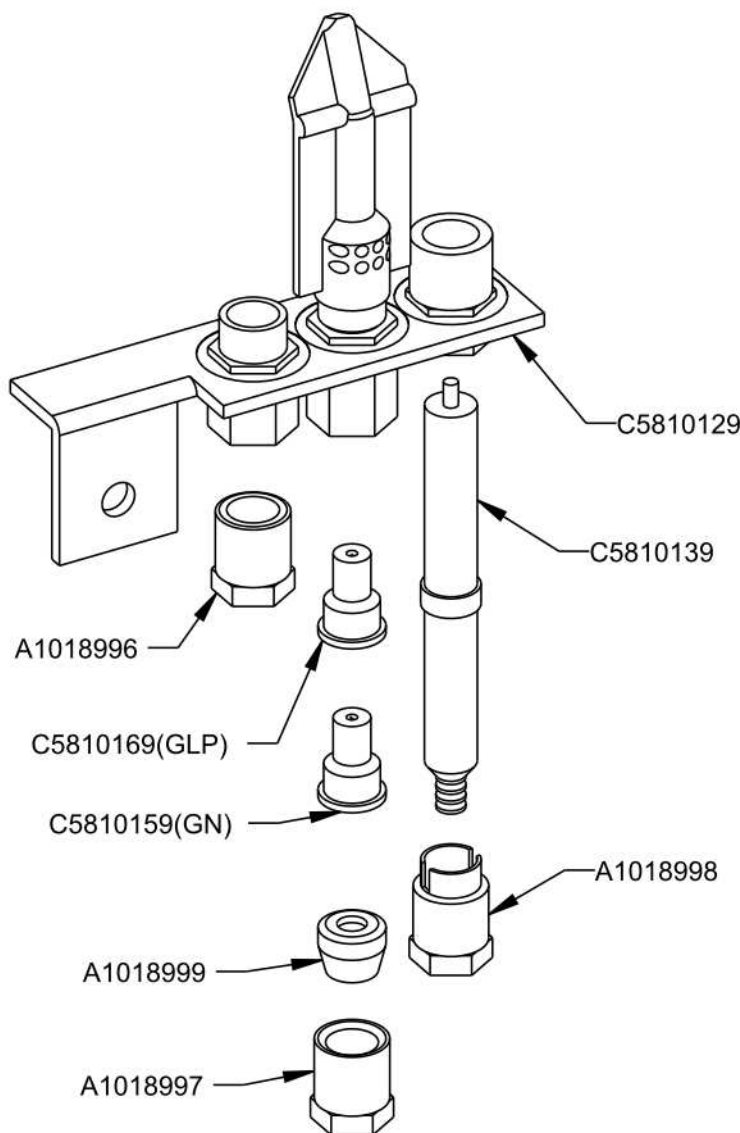

FAMILIA: COCINAS 2008

FECHA: 28/01/11

MODELO: 3611

PESO(Kg): 0.074

DENOMINACION:  
PILOTO POLIDORO COMPLETO

ESCALA:  
1/1

MATERIAL:  
FE

CODIGO:  
C5810129M



**Applus®**  
LGA1  
Organismo  
Notificado  
**0370**

**AENOR**  
Organismo  
Notificado  
**0099**



TOLERANCIAS GENERALES: ±0.5 mm

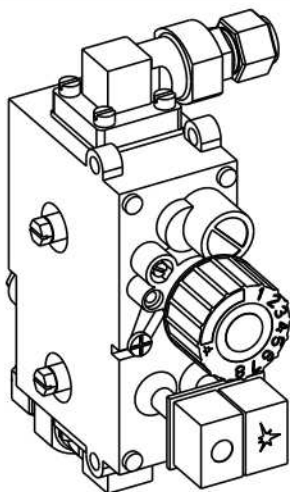

QT	COD	DESCRIPCION
2	3782	BICONO D.10 LATON
2	C5810419	CODO 90° -3/8" SIT S/R.0906252
2	3785	JUNTA VALVULA MINISIT
2	362489P	MACHON D.10 - 3/8" - M16X1.5
1	3765	MANDO VALV. SIT
8	1051	TORNILLO ZN M4X15 DIN 84
2	3781	TUERCA M16X1.5 D.10
1	C5815359	TUERCA+BICONO D.6 M10X1
1	3103	VALVULA MINI SIT

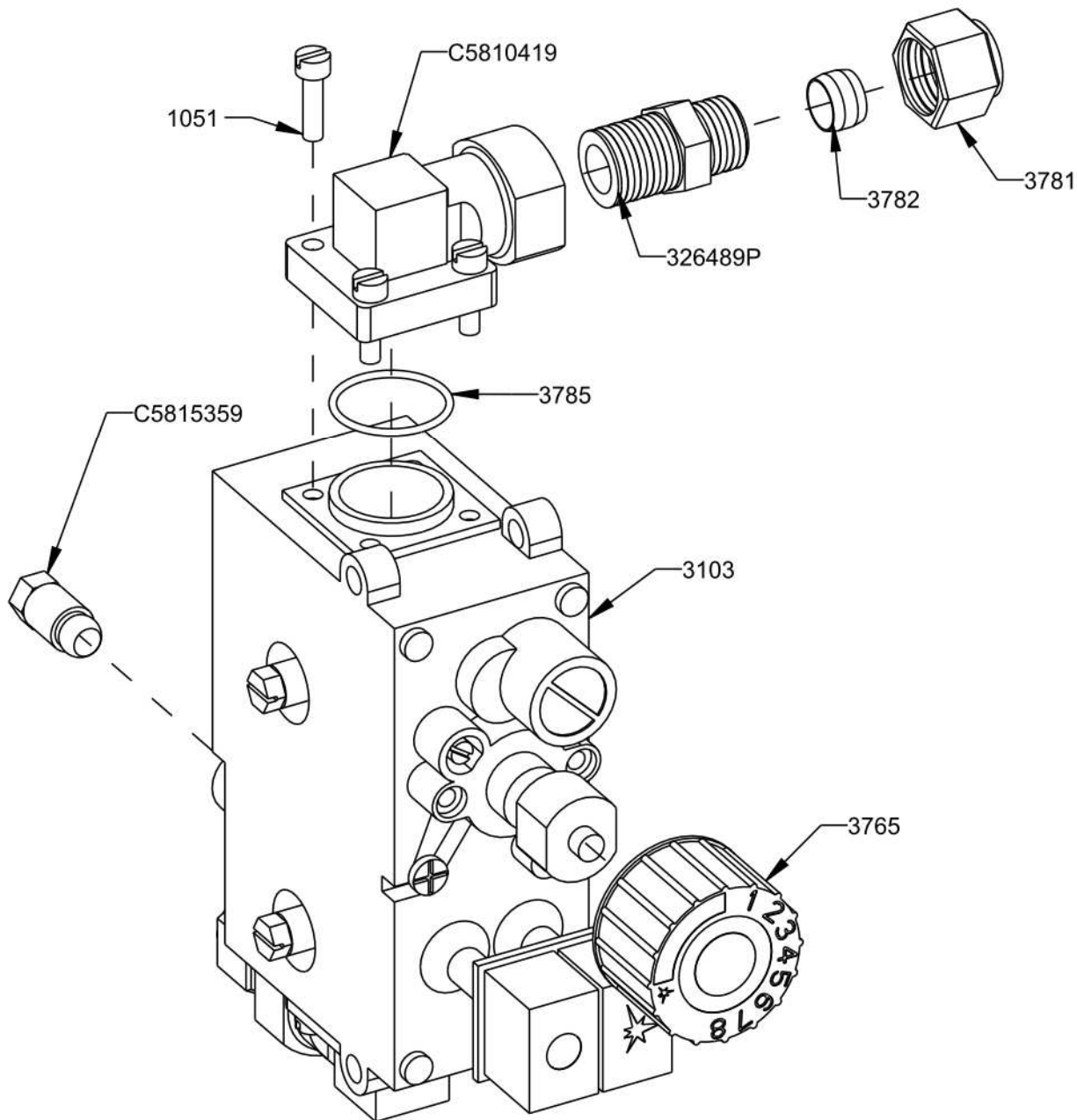

FAMILIA: COCINAS 2008

FECHA: 05/09/08

MODELO: 3611

PESO(Kg): 0.940

DENOMINACION:  
VALVULA SIT COMPLETA

ESCALA:  
1/2

MATERIAL:  
AL

CODIGO:  
3103M