

NM950R SERVICE PARTS

This parts list contains the service parts and wiring diagrams for this model. Check the model number in question to be sure that it is applicable to this parts list.

TABLE OF CONTENTS

Cabinet	2
Refrigeration	3
Water	4
Gearmotor.....	5
Evaporator	6
Control Box.....	7
Remote Condenser	8
Wiring Diagrams.....	9

NM950R SERVICE PARTS

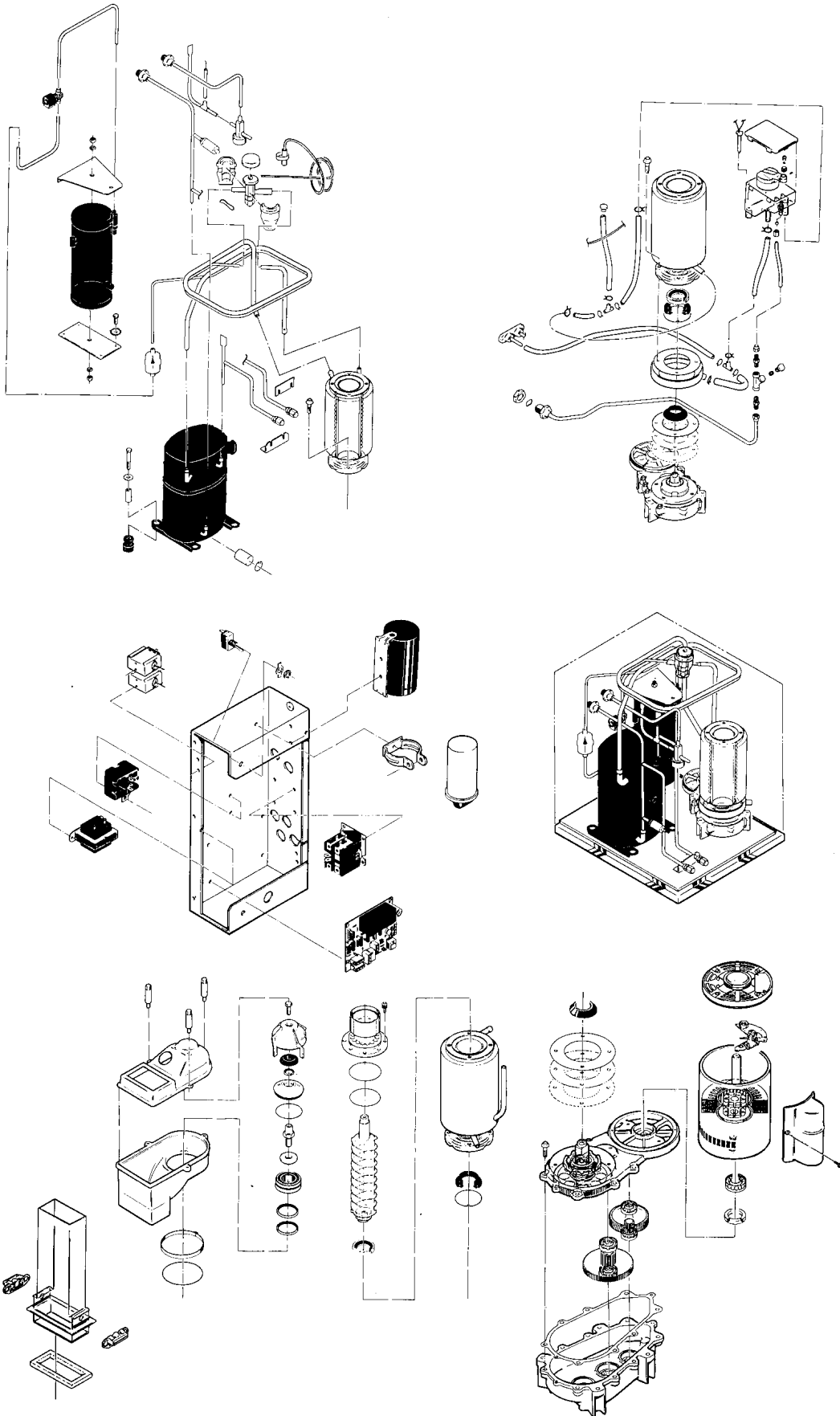

NM950R SERVICE PARTS

Cabinet Assembly

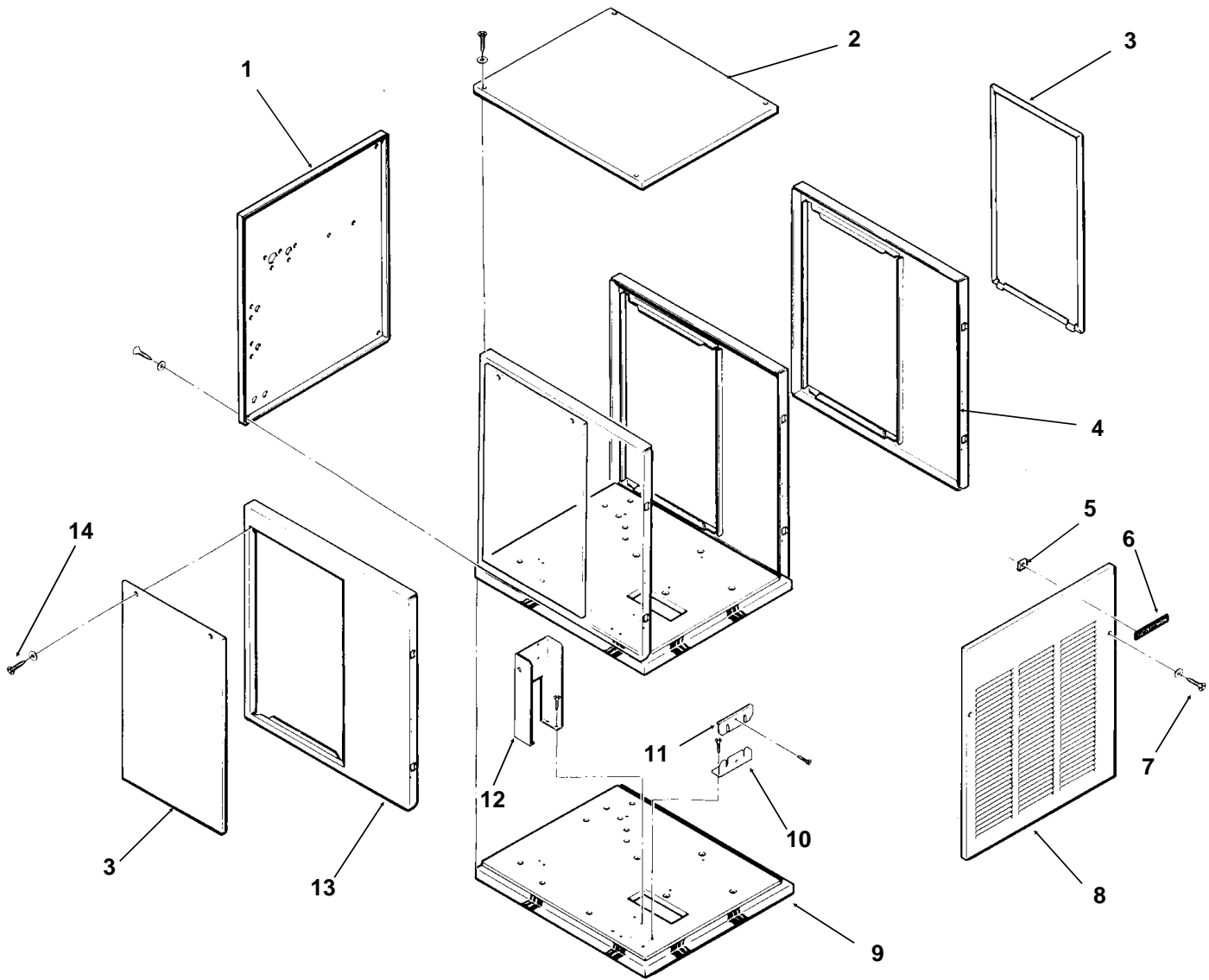

ITEM NUMBER	PART NUMBER	DESCRIPTION	ITEM NUMBER	PART NUMBER	DESCRIPTION
1	A33252-001	Back Panel, Painted	8	A33255-001	Front Panel, Painted
2	A33256-001	Top Panel, Painted		A33255-002	Front Panel, S.S.
	A33256-002	Top Panel, S.S.	9	A34042-001	Base Assembly
3	A34038-001	Service Panel, Painted	10	A31462-001	Tube Bracket
	A34038-002	Service Panel, S.S.	11	A31461-001	Tube Bracket
4	A33292-001	Right Side Panel, Painted	12	A34039-001	Control Box Support
	A33292-002	Right Side Panel, S.S.	13	A32435-001	Left Side Panel, Painted
5	03-0271-00	Speed Clip		A32435-002	Left Side Panel, S.S.
6	15-0711-01	Emblem	14	03-1404-12	Screw
7	03-1419-08	Screw			

NM950R SERVICE PARTS

Refrigeration System

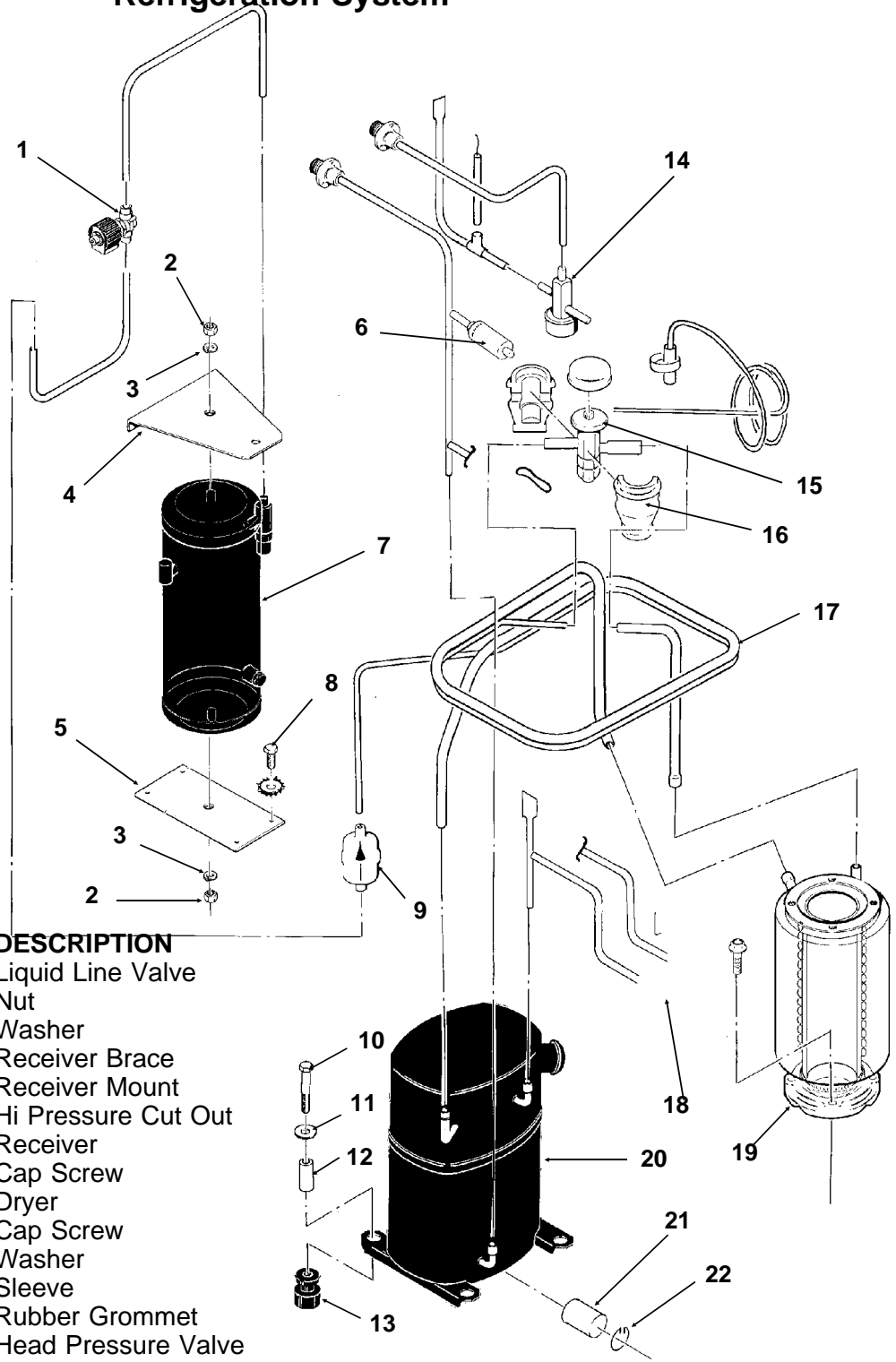

NOTE: Compressors have internal overloads.

ITEM NUMBER	PART NUMBER	DESCRIPTION
1	12-2257-21	Liquid Line Valve
2	03-1406-13	Nut
3	03-1410-06	Washer
4	A32968-001	Receiver Brace
5	A31801-002	Receiver Mount
6	11-0446-23	Hi Pressure Cut Out
7	16-0761-01	Receiver
8	03-1645-01	Cap Screw
9	02-3319-02	Dryer
10	03-1405-20	Cap Screw
11	03-1407-07	Washer
12	18-2300-26	Sleeve
13	18-6800-01	Rubber Grommet
14	11-0422-22	Head Pressure Valve
15	16-0780-21	Thermo Expansion Valve
16	A32961-020	Insulation Kit for TXV
17	A34050-001	Suction Line
18	16-0560-00	Core
18	16-0563-00	Nut

ITEM NUMBER	PART NUMBER	DESCRIPTION
19	A32890-020	Evaporator
20	18-8879-21	Compressor (1 Phase)
	18-8879-22	Compressor (3 Phase)
21	18-2308-01	Crankcase Heater
22	18-2309-01	Clip

NM950R SERVICE PARTS

Water System, Water Seal

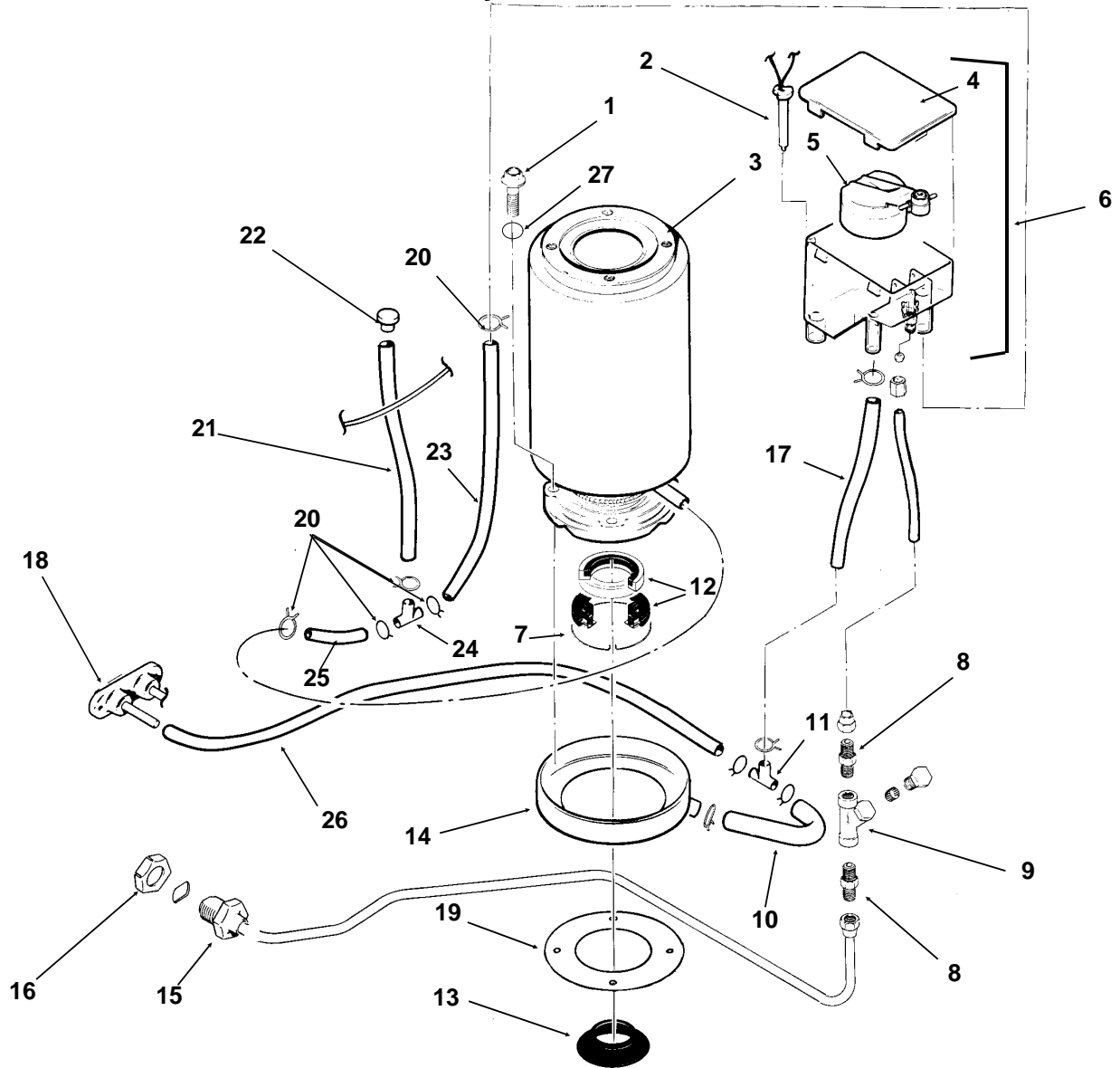

ITEM NUMBER	PART NUMBER	DESCRIPTION	ITEM NUMBER	PART NUMBER	DESCRIPTION
1	03-1420-03	Cap Screw	14	A32050-001	Drip Pan
2	A33101-022	Water Level Sensor	15	A27318-001	Water Inlet Fitting
3	A32890-020	Evaporator	16	03-1394-01	Pal Nut
4	02-2936-01	Res. Cover	17	13-0079-03	Res. Overflow, 8" req.
5	A32922-020	Float Assembly with pin, housing seal, rubber seal, insert & float	18	A34045-001	Drain Casting
6	A32929-020	Reservoir Assembly	19	13-0704-00	Gasket
7	A32777-001	Retaining Ring for Seal	20	02-2814-08	Clamps
8	16-0791-01	Half Union	21	13-0674-06	Evap. Drain, 14" req.
9	16-0162-00	Strainer	22	A33205-001	Plug
10	13-0079-03	Tube, 3.2" req.	23	13-0674-06	Evap. Inlet Tube, 5" req.
11	16-0670-02	Tee	24	16-0670-01	Tee
12	02-0929-23	Water Seal	25	A33203-001	Tube, Preformed
13	13-0868-01	Water Shed	26	13-0079-03	Drain Tube, 24" req.
			27.	03-1417-13	Lockwasher

NM950R SERVICE PARTS

Gearmotor

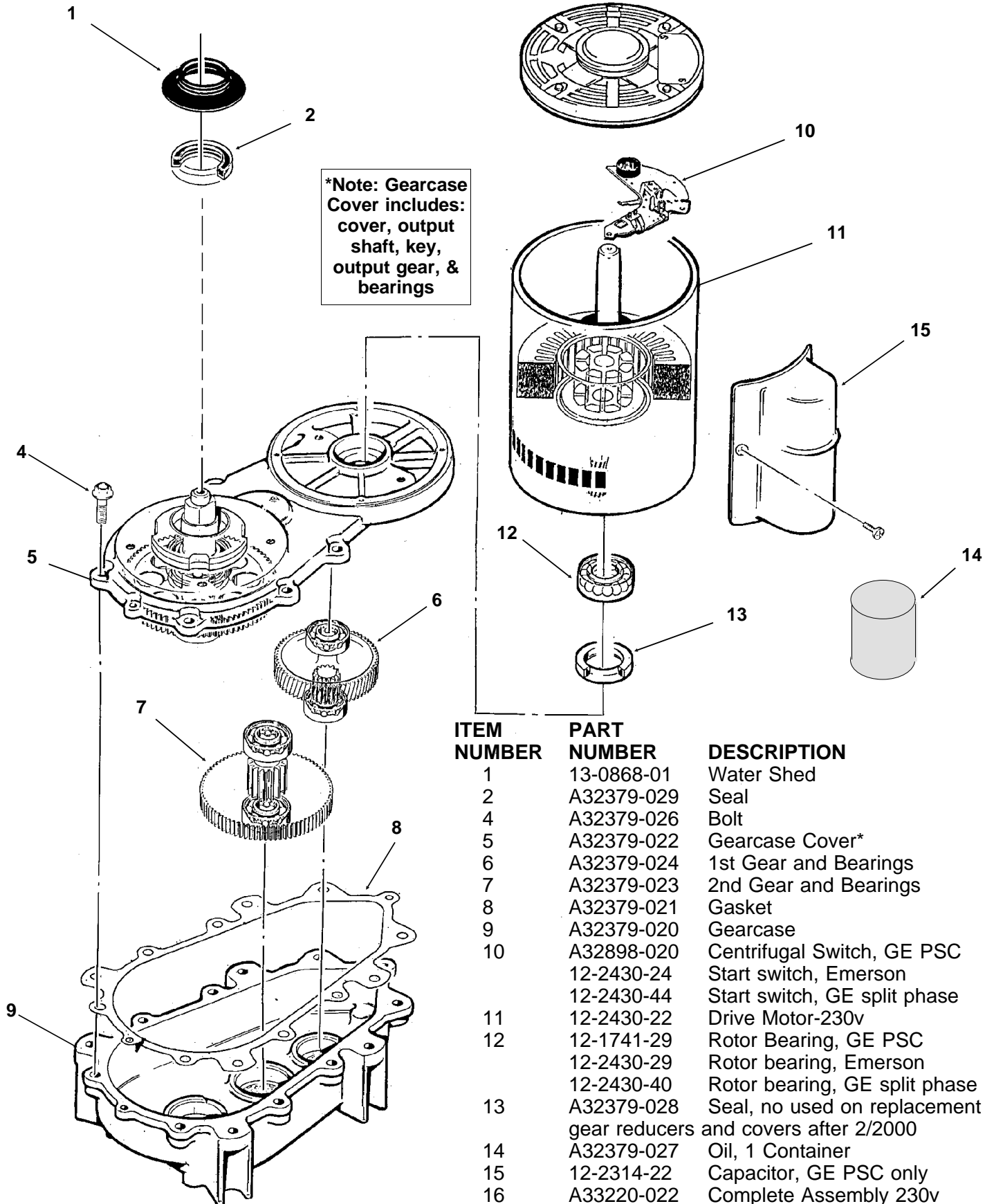

ITEM NUMBER	PART NUMBER	DESCRIPTION
1	13-0868-01	Water Shed
2	A32379-029	Seal
4	A32379-026	Bolt
5	A32379-022	Gearcase Cover*
6	A32379-024	1st Gear and Bearings
7	A32379-023	2nd Gear and Bearings
8	A32379-021	Gasket
9	A32379-020	Gearcase
10	A32898-020	Centrifugal Switch, GE PSC
	12-2430-24	Start switch, Emerson
	12-2430-44	Start switch, GE split phase
11	12-2430-22	Drive Motor-230v
12	12-1741-29	Rotor Bearing, GE PSC
	12-2430-29	Rotor bearing, Emerson
	12-2430-40	Rotor bearing, GE split phase
13	A32379-028	Seal, no used on replacement gear reducers and covers after 2/2000
14	A32379-027	Oil, 1 Container
15	12-2314-22	Capacitor, GE PSC only
16	A33220-022	Complete Assembly 230v
	A33220-030	Gears, oil & cases. No motor.

NM950R SERVICE PARTS

Evaporator, Bin Controls

Spanner Wrench:
Part Number: A34773-001

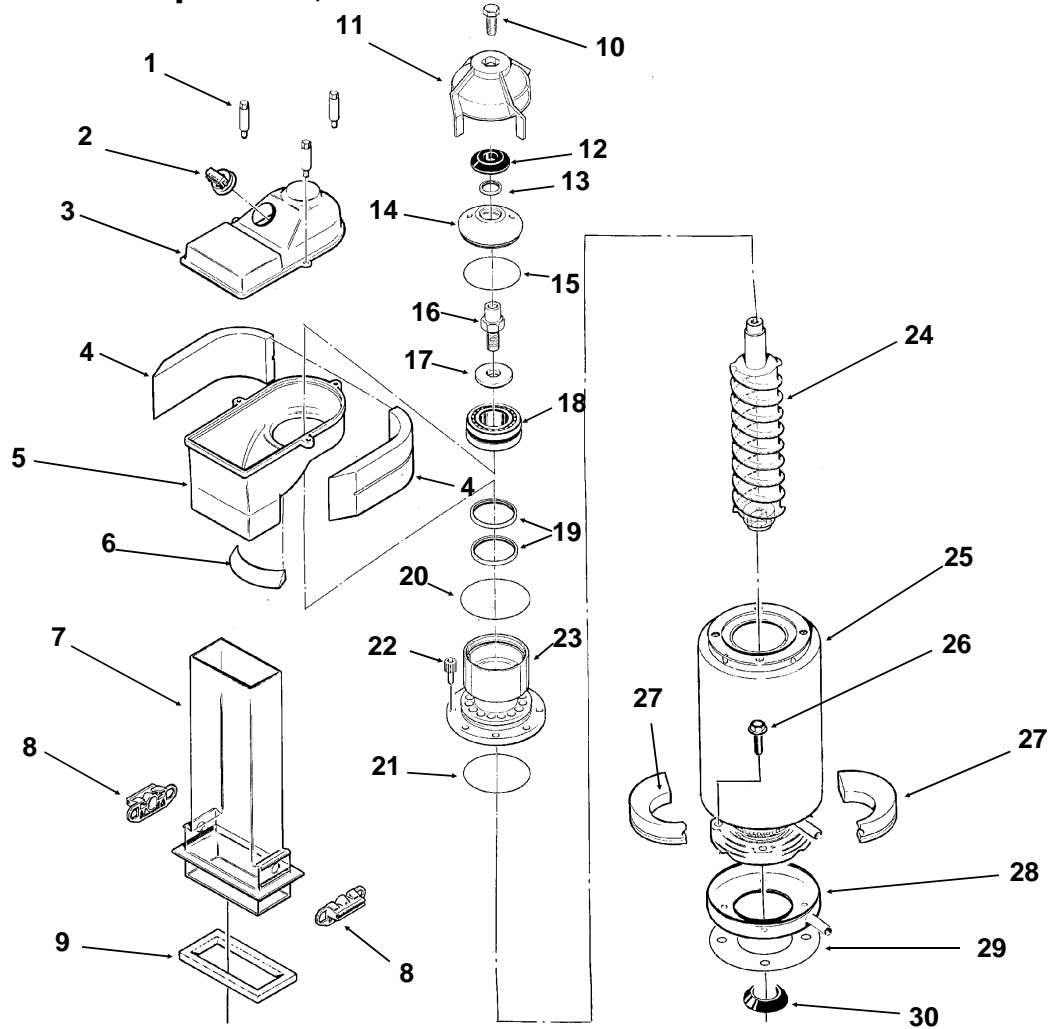

ITEM NUMBER	PART NUMBER	DESCRIPTION
1.	02-2933-01	Hex Stud
2.	A32891-020	Man. switch & hsng assy
	12-2398-01	Manual reset switch only
	12-2329-01	Auto reset switch only
	13-0617-53	O-Ring for above
3.	02-2930-01	Ice Chute Cover
4.	A32963-001	Insulation Top (half)
5.	02-2926-01	Ice Chute Body
	A32905-001	Clamp, chute to breaker
6.	A33102-001	Insulation Collar Inside
	A33210-001	Rubber Band
7.	02-2929-02	Ice Chute Lower
8.	A37708-021	Bin Controls
9.	A32930-001	Chute Gasket
10.	03-1405-52	Hex Cap Screw
11.	02-3001-01	Ice Sweep
12.	13-0871-01	Water Shed
13.	02-2978-01	Lip Seal
14.	02-3128-20	Breaker Cover
	15.	13-0617-54 O-Ring
	16.	08-0660-01 Auger Stud & Washer
	17.	no number part of item 16
	18.	A34559-020 Bearing
	19.	02-2977-01 Lip Seal
	20.	13-0617-52 O-Ring
	21.	13-0617-45 O-Ring
	22.	03-1544-08 Soc. Head Screw
	23.	A32900-020 Breaker (includes 18 & 19)
	24.	A38071-022 Auger
	25.	A32890-020 Evaporator
	26.	03-1405-41 Cap Screw
	27.	A32962-001 Insulation Bot. (half)
		A32962-002 Insulation half
	28.	A32050-001 Drip Pan
	29.	13-0704-00 Drip Pan Gasket
	30.	13-0868-01 Water Shed

NM950R SERVICE PARTS

Control Box

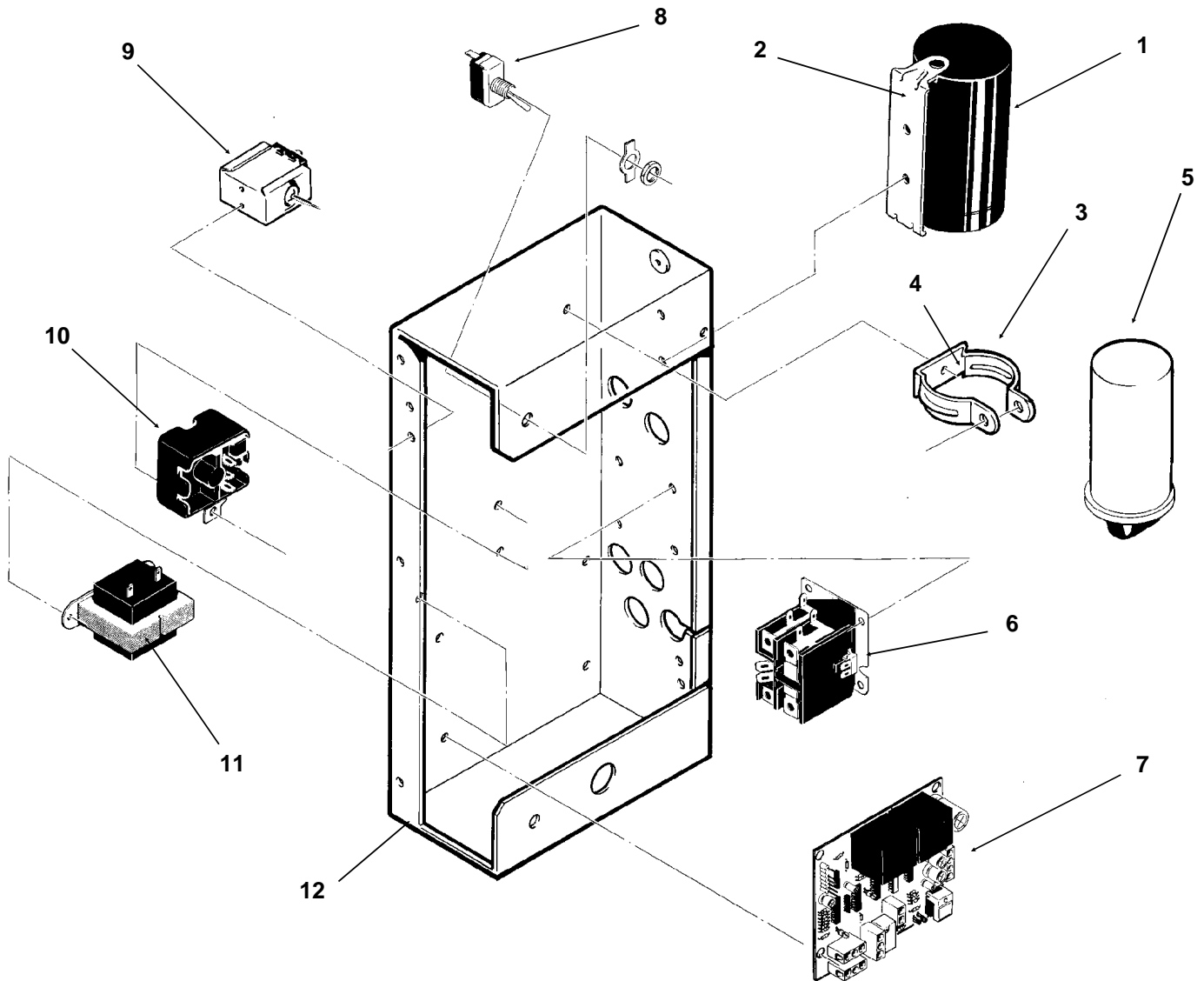

ITEM NUMBER	PART NUMBER	DESCRIPTION	ITEM NUMBER	PART NUMBER	DESCRIPTION
1	18-1901-48	Start Capacitor	7	A37750-021	Circuit Board
	18-4300-50	Start Capacitor Cap.	8.	12-0426-01	Master Switch
2.	18-2200-39	Start Capacitor Bracket	9.	11-0420-23	Pump Down Control
	03-1638-04	Screw	10	18-1903-46	Potential Relay
	03-1417-15	Lockwasher	11.	12-2285-22	Transformer
3.	A32872-001	Run Cap Bracket	12	no number	Control Box Assy
	03-1652-02	Bolt	NOT ILLUSTRATED		
	03-0255-04	Wing Nut	13.	12-2337-02	3 Pin Plug Assy (Safety Circuit to Circuit Board)
4.	03-1638-03	Screw	14.	12-2340-01	4 Pin Plug Assy (Transformer to Circuit Board)
5.	18-1902-45	Run Capacitor	15.	A34055-001	Control box cover
6.	12-2469-03	Single Phase Contactor			
	12-0739-02	Three Phase Contactor			

NM950R SERVICE PARTS REMOTE CONDENSER

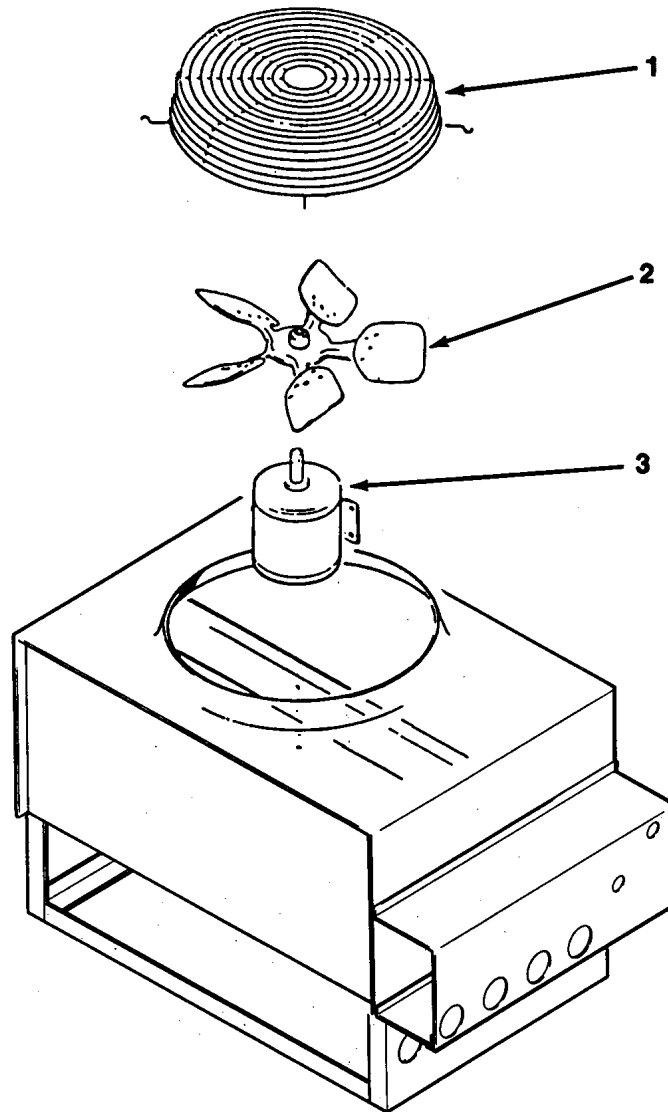

RC1451-32B or
RC1051-32A or RC1052-32A

ITEM NUMBER	PART NUMBER	DESCRIPTION
1.	02-2628-01	Fan Guard
2.	18-6304-01	Fan Blade
3.	18-5301-01	Fan Motor

RC651-32B or RC652-32B

ITEM NUMBER	PART NUMBER	DESCRIPTION
1.	02-2618-01	Fan Guard
2.	18-3733-01	Fan Blade
3.	18-5301-01	Fan Motor

NM950R SERVICE PARTS

Component Layout Diagram, 208-230/60/1

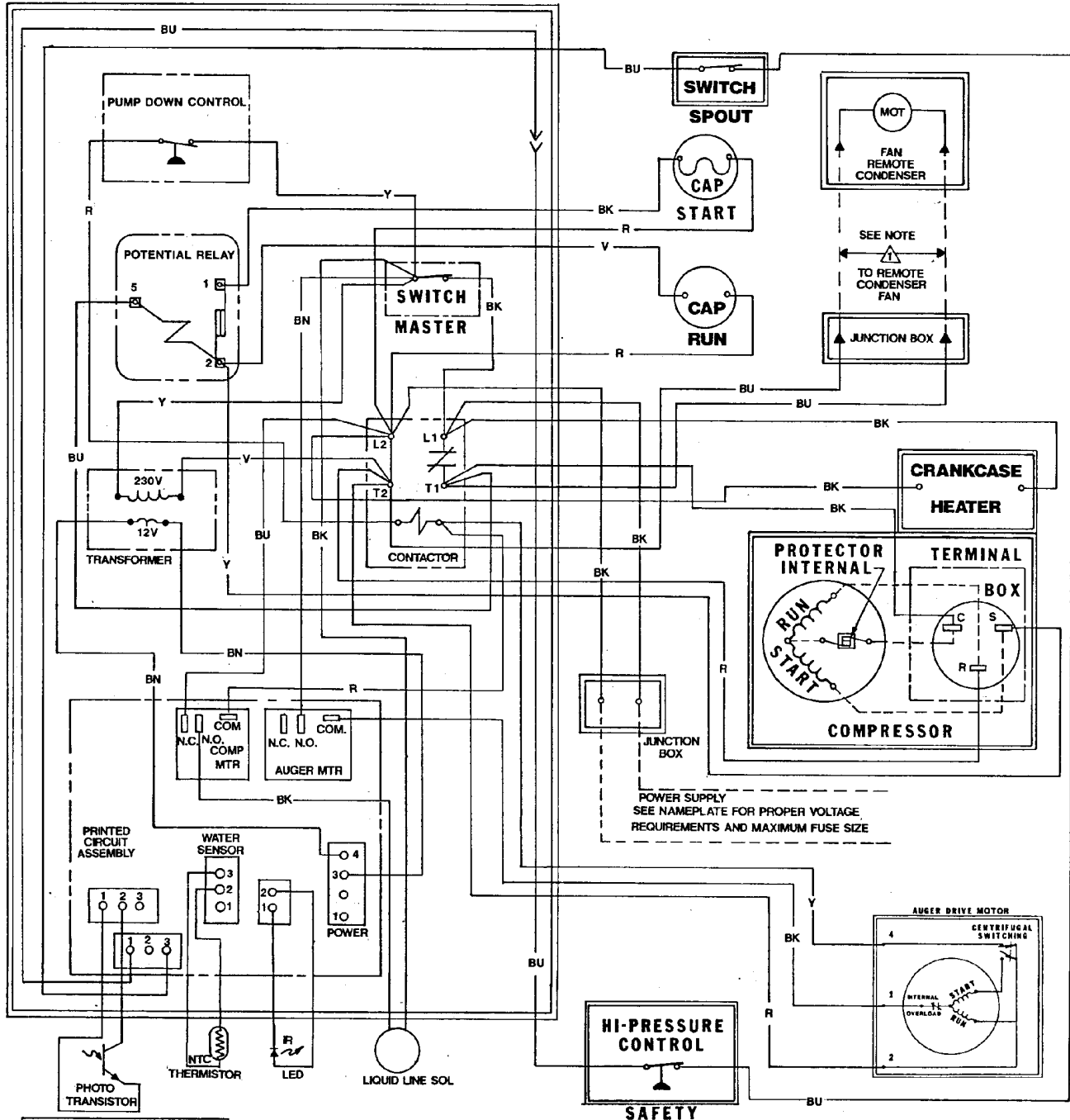

A34492-032

NM950R SERVICE PARTS

Component Layout Diagram, 208-230/60/1

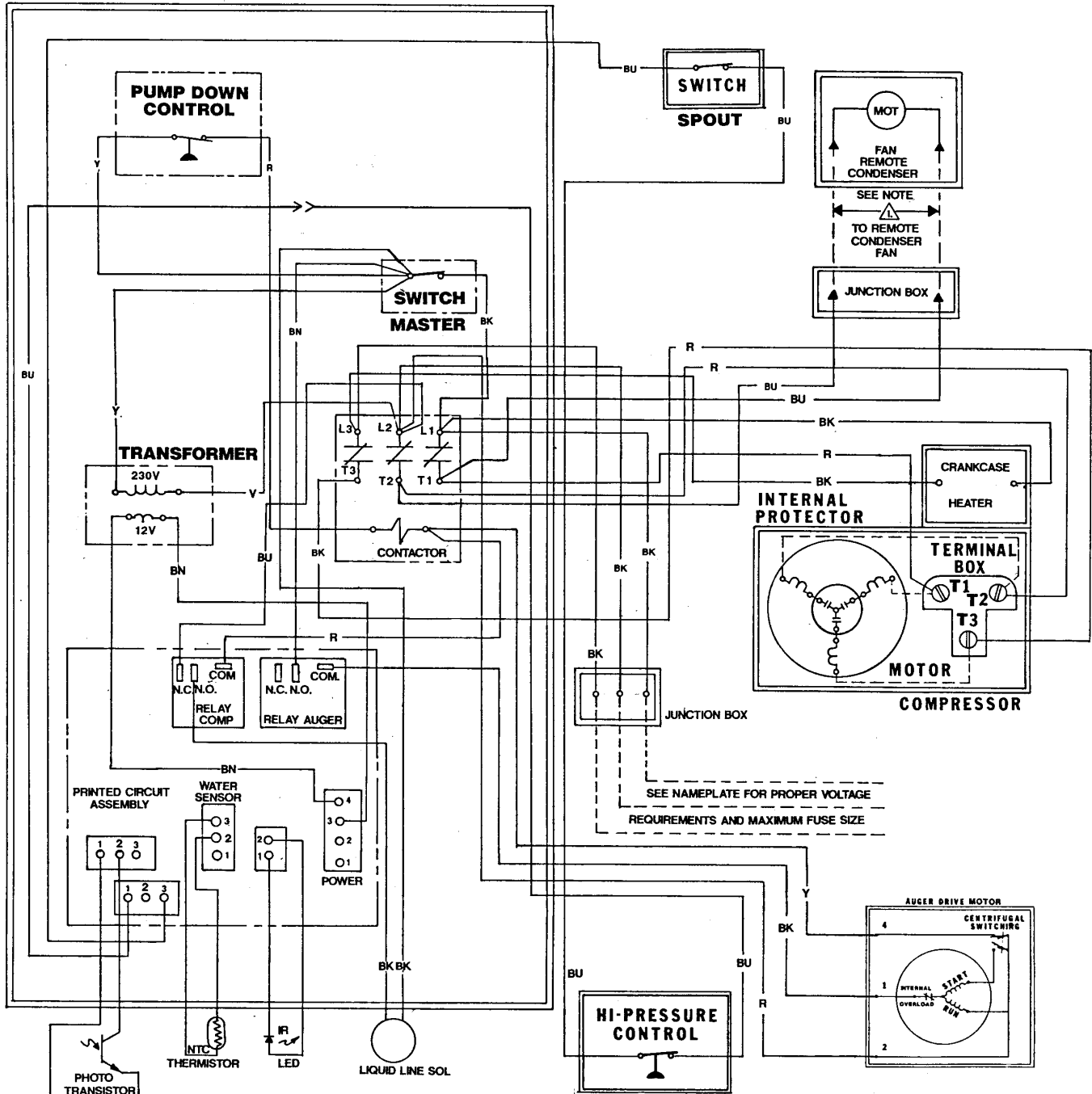

A34492-003

NM950R SERVICE PARTS

Schematic Diagram, 208-230/60/3

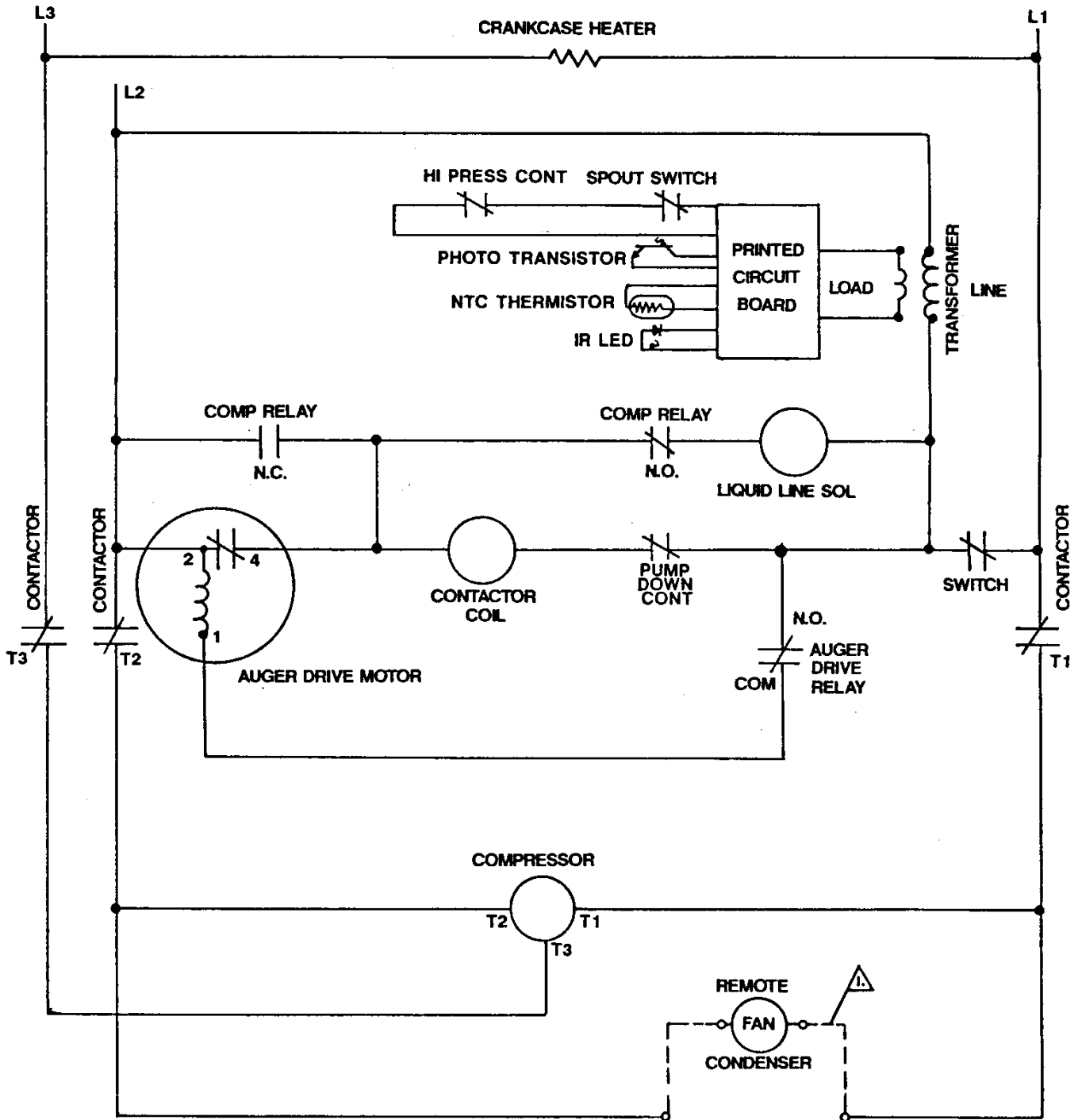

USE COPPER CONDUCTORS ONLY THIS UNIT MUST BE GROUNDED

All Controls Shown in Normal Ice Making Mode.

Note: Dashed lines indicate field wiring which must be installed in accordance with the National Electric Code Using a Minimum of 14 ga. awg. wire.