



Applus®
LGA1
Organismo
Notificado
0370

AENOR
Organismo
Notificado
0099



TOLERANCIAS GENERALES: ±0.5 mm

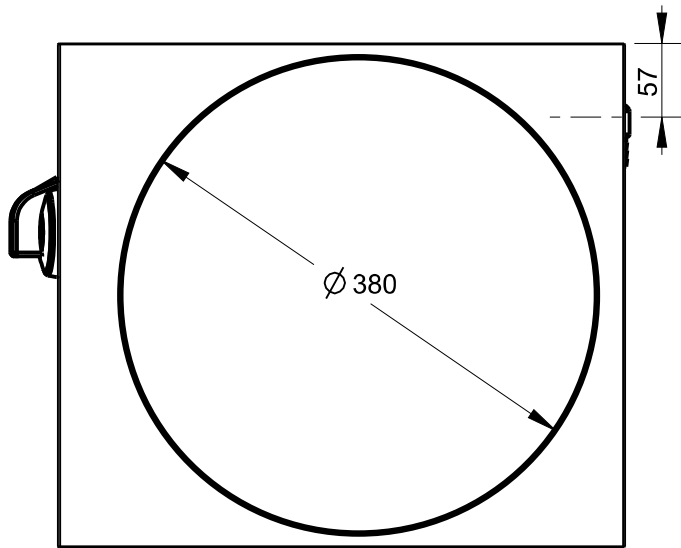
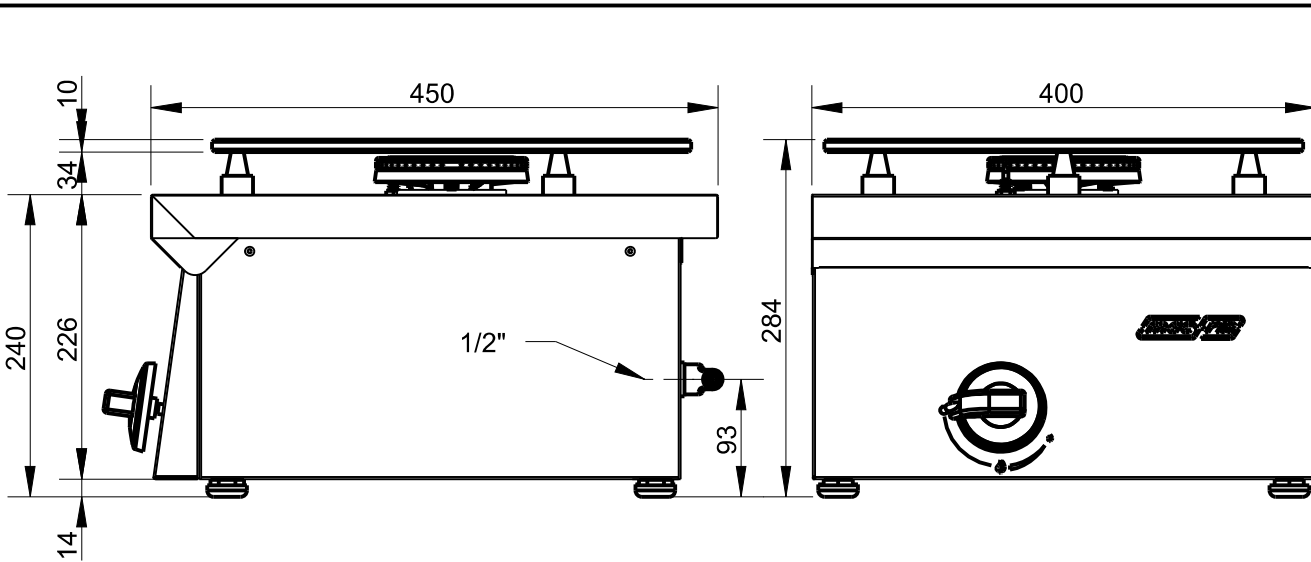

DISCO EXTRAÍBLE
PARA FACILITAR SU
LIMPIEZA

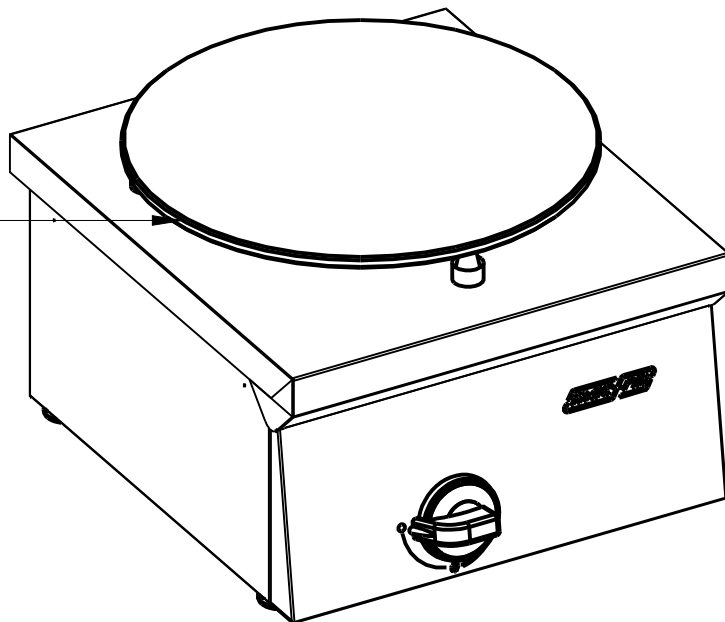

FAMILIA: BAR 2009

FECHA: 29/08/11

MODELO: 4416

PESO(Kg): 17.037

DENOMINACION:
CREPERA 1 PLACA GAS

ESCALA:
1/6

MATERIAL:
INOX

CODIGO:
4416



Applus®
LGA1
Organismo
Notificado
0370

AENOR
Organismo
Notificado
0099



TOLERANCIAS GENERALES: ±0.5 mm

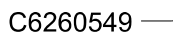
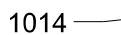
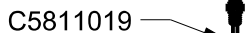
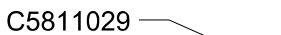
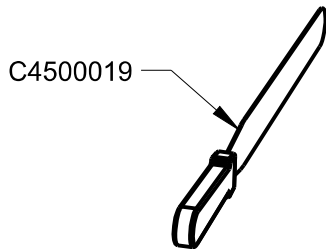
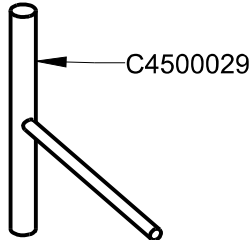
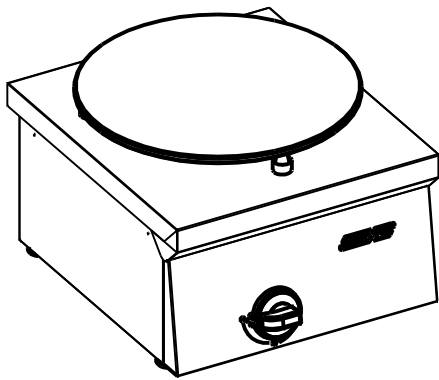

QT	COD	DESCRIPCION
4	1014	REMACHE ROSCADO M-10
1	3057	TETINA 1/2"
1	440226	ENVOLVENTE BAR 400
1	440294	SOPORTE IZQ. BATERÍA BAR
1	440476	SOPORTE BATERÍA CORTA
1	441601	SOBRE CREPERA GAS 400
1	441639	FRONTAL MANDOS CREPERA GAS 400
1	443214	REFUERZO SOBRE BAR 400
1	340173PM	CONJUNTO MANDO A GAS
1	440285PC	BATERIA COMP.BAR 300
3	440389P	CENTRADOR PLANCHA
1	441601P	PLACA CREPERA D.380 PAVONADA
3	506189P	DISTANCIADOR PASAPLATOS
1	C4500019	ESPATULA CREPERA
1	C4500029	DISPENSADOR CREPERA
1	C5811019	TERMOPAR M8 C/ROSCADA L.320
2	C5811029	TUERCA TERMOPAR M8
1	C5815599M	CONJ.QUEMADOR ULTRA R.
1	C5816299M	CONJUNTO GRIFO EJE CORTO
4	C6260549	PATA PA M-10X30 BASE D.30
1	T08030	TUBO AL D.8 L.300

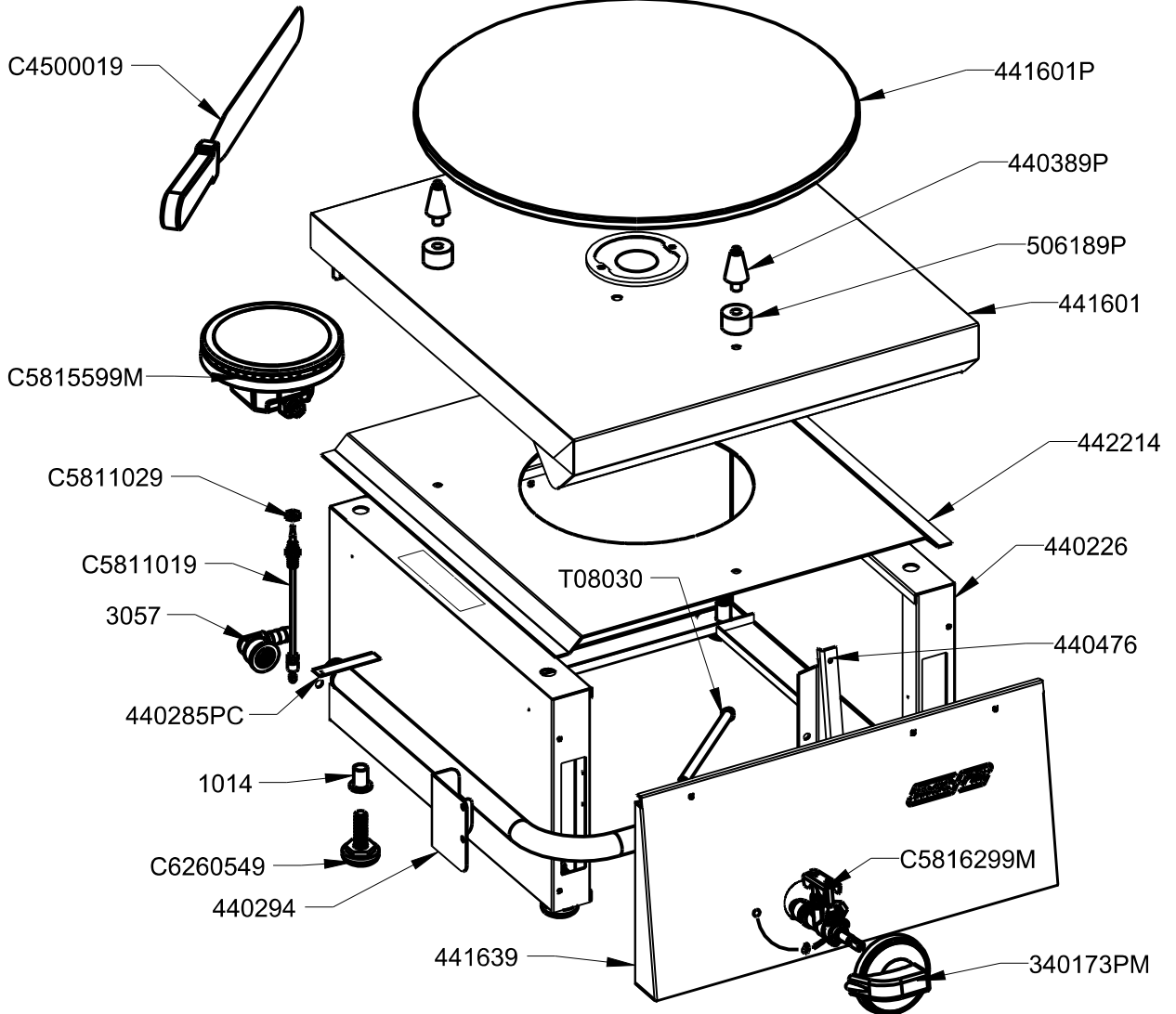

FAMILIA: BAR 2009

FECHA: 29/08/11

MODELO: 4416

PESO(Kg): 17.037

DENOMINACION:
CREPERA 1 PLACA GAS

ESCALA:
1/6

MATERIAL:
INOX

CODIGO:
4416



Applus®
LGA1
Organismo
Notificado
0370

AENOR
Organismo
Notificado
0099



TOLERANCIAS GENERALES: ±0.5 mm

QT	COD	DESCRIPCION	FAB.	MATERIAL	DATA
2	330294	PLETINA BASE BATERÍA	SÍ	FE 1.5	03/11/08
1	440226	ENVOLVENTE BAR 400	SÍ	INOFER 0.8	04/03/10
1	440294	SOPORTE IZQ. BATERÍA BAR	SÍ	GALVA 1.5	03/03/10
1	440476	SOPORTE BATERÍA CORTA	SÍ	GALVA 1.5	07/04/10
1	441601	SOBRE CREPERA GAS 400	SÍ	INOFER 0.8	12/05/10
1	441639	FRONTAL MANDOS CREPERA GAS 400	SÍ	INOFER 0.8	16/11/10
1	443214	REFUERZO SOBRE BAR 400	SÍ	GALVA 1.5	06/05/10
4	1014	REMACHE ROSCADO M-10	NO	ZN	17/12/09
1	3057	TETINA 1/2"	NO	LATON	01/01/01
1	31691	BRIDA 1/2" SABAF	NO	FE ZN	13/02/09
1	340172P	EMBELLECEDOR MANDO GAS/ELECT.	NO	ABS	10/12/07
1	340173P	MANDO COCINA GAS 2008	NO	BAQUELITA	10/12/07
1	340173PM	CONJUNTO MANDO A GAS	NO	BAQUELITA	10/12/07
1	440285P	BATERIA BAR 300	NO	FE 1/2"	20/04/11
1	440285PC	BATERIA COMP.BAR 300	NO	FE ZINCADO	20/04/11
3	440389P	CENTRADOR PLANCHA	NO	FE CROMADO	08/02/10
1	441601P	PLACA CREPERA D.380 PAVONADA	NO	FE 10	28/04/10
3	506189P	DISTANCIADOR PASAPLATOS	NO	INOX	14/10/08
2	C1061243	TORNILLO M-4X25 DIN933 ZN	NO	FE ZN	12/02/09
2	C1063249	TORNILLO M-4X6 DIN 7985 ZN	NO	FE ZN	01/01/08
1	C4500019	ESPATULA CREPERA	NO	INOX	06/05/10
1	C4500029	DISPENSADOR CREPERA	NO	MADERA	10/05/11
1	C5811019	TERMOPAR M8 C/ROSCADA L.320	NO	CU	09/02/09
2	C5811029	TUERCA TERMOPAR M8	NO	CU	01/01/08
2	C5815559	BICONO D.8 SABAF	NO	LATON	13/02/09
1	C5815569	TUERCA 1/4" D.8 SABAF	NO	FE ZN	13/02/09
1	C5815579	ANILLO QUEMADOR ULTRA R.	NO	LATON	09/09/09
1	C5815589	TAPA QUEMADOR ULTRA R.	NO	FUNDICION	09/09/09
1	C5815599	SOPORTE QUEMADOR ULTRA R.	NO	ALUMINIO	09/09/09
1	C5815599M	CONJ.QUEMADOR ULTRA R.	NO	ALUMINIO	09/09/09
1	C5815609	COPA QUEMADOR ULTRA R.	NO	ALUMINIO	09/09/09
1	C5815619	TUERCA TUBO QUEM.ULTRA	NO	FE ZN	09/09/09
1	C5815629	INYECTOR GN D=1.67 M-6X0.75	NO	LATON	09/09/09
1	C5815639	INYECTOR GLP D=1.10 M-6X0.75	NO	LATON	09/09/09
1	C5816299	GRIFO PLANCHA BAR	NO	LATON	09/09/09
1	C5816299M	CONJUNTO GRIFO EJE CORTO	NO	LATON	09/09/09
1	C5816309	TOMA DE PRESIÓN PARA BATERIA	NO	LATON	31/03/11
4	C6260549	PATA PA M-10X30 BASE D.30	NO	PA NEGRA	15/04/10
1	T08030	TUBO AL D.8 L.300	NO	AL 99.7%	02/06/09



FAMILIA: BAR 2009

FECHA: 29/08/11

MODELO: 4416

PESO(Kg): 17.037

DENOMINACION:
CREPERA 1 PLACA GAS

ESCALA:
1/6

MATERIAL:
INOX

CODIGO:
4416



ISO 9001
BUREAU VERITAS
Certification



ISO 14001
BUREAU VERITAS
Certification



Applus®
LGA1
Organismo
Notificado
0370

AENOR
Organismo
Notificado
0099

FUNDADA EN 1878
MASBAGA
GRANDES COCINAS

EURAST

mac-fini

TOLERANCIAS GENERALES: ±0.5 mm

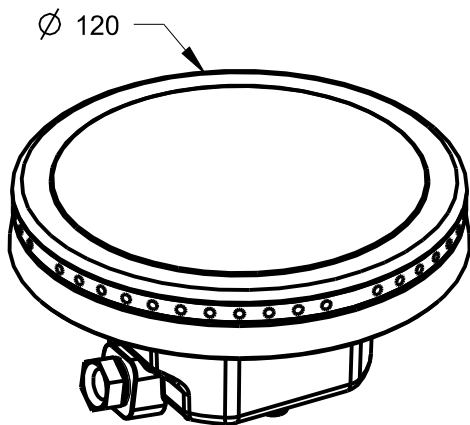

QT	COD	DESCRIPCION
2	C1063249	TORNILLO M-4X6 DIN 7985 ZN
1	C5815559	BICONO D.8 SABAF
1	C5815579	ANILLO QUEMADOR ULTRA R.
1	C5815589	TAPA QUEMADOR ULTRA R.
1	C5815599	SOPORTE QUEMADOR ULTRA R.
1	C5815609	COPA QUEMADOR ULTRA R.
1	C5815619	TUERCA TUBO QUEM.ULTRA
1	C5815629	INYECTOR GN D=1.67 M-6X0.75
1	C5815639	INYECTOR GLP D=1.10 M-6X0.75

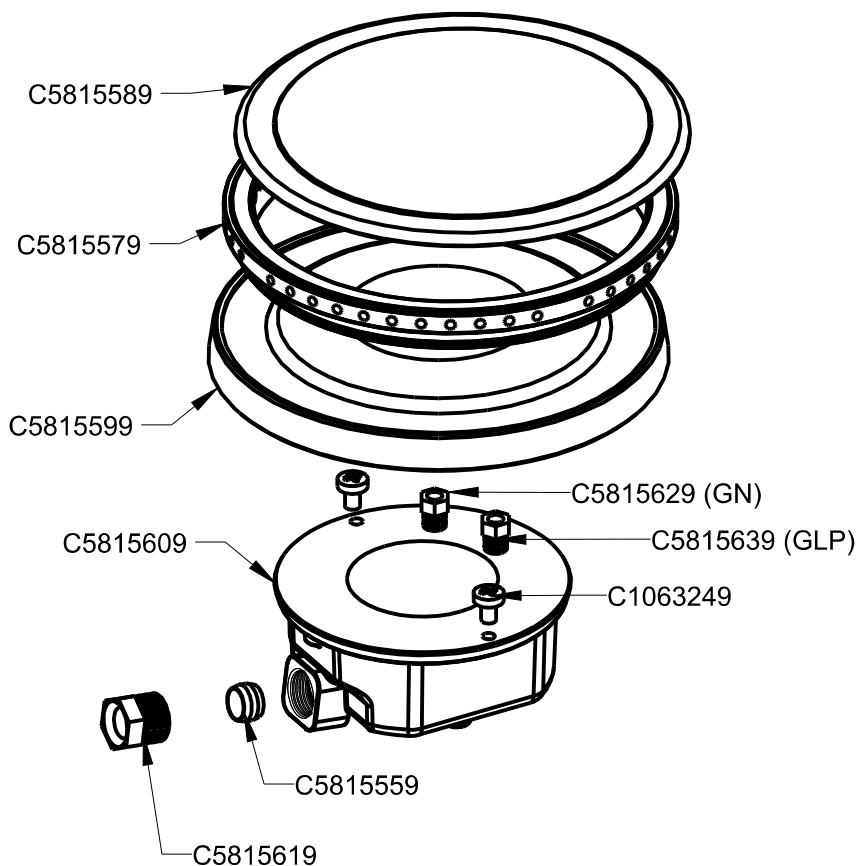

FAMILIA: BAR 2009

FECHA: 09/09/09

MODELO: 4412

PESO(Kg): 0.765

DENOMINACION:
CONJ.QUEMADOR ULTRA R.

ESCALA:
1/2

MATERIAL:
ALUMINIO

CODIGO:
C5815599M



Applus®
LGA1
Organismo
Notificado
0370

AENOR
Organismo
Notificado
0099



TOLERANCIAS GENERALES: ±0.5 mm

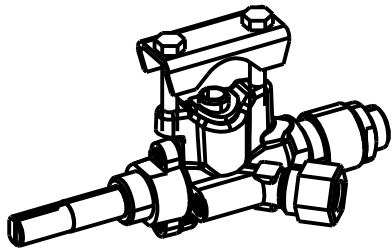

ESCALA 1/2

QT	COD	DESCRIPCION
1	31691	BRIDA 1/2" SABAF
2	C1061243	TORNILLO M-4X25 DIN933 ZN
1	C5815559	BICONO D.8 SABAF
1	C5815569	TUERCA 1/4" D.8 SABAF
1	C5816299	GRIFO PLANCHA BAR

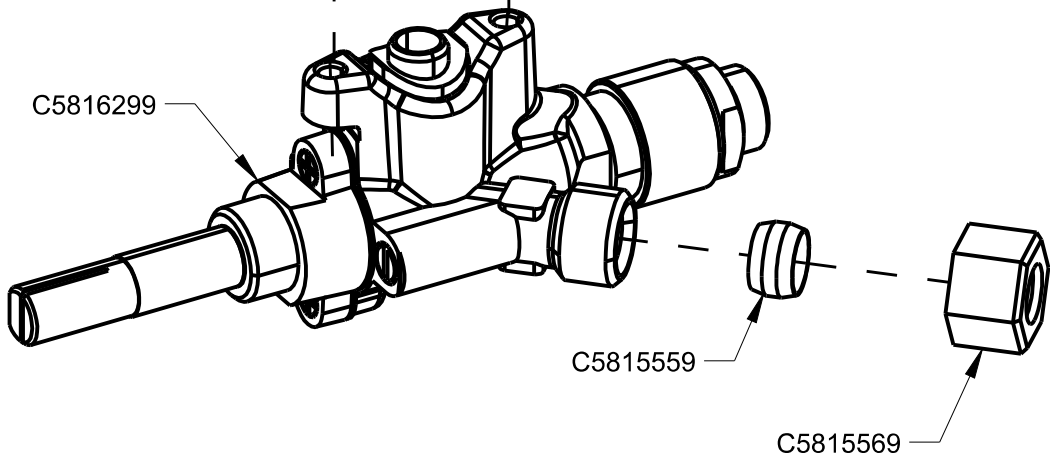
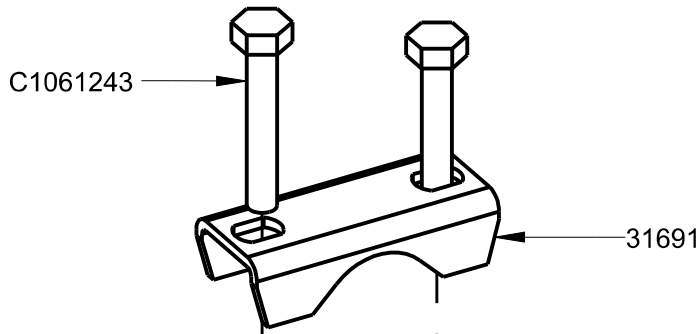
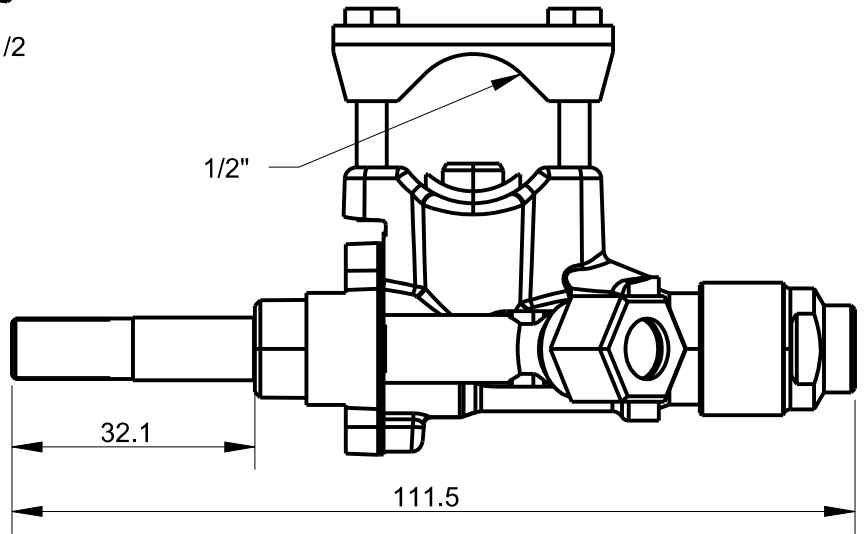

FAMILIA: BAR 2009

FECHA: 09/09/09

MODELO: 4412

PESO(Kg): 0.227

DENOMINACION:
CONJUNTO GRIFO EJE CORTO

ESCALA:
1/1

MATERIAL:
LATON

CODIGO:
C5816299M