

LAVASTOVIGLIE A NASTRO
FLIGHT DISHWASHING MACHINES
LAVE-VAISSELLE A CONVOYEUR
BANDAUTOMAT
LAVAVAJILLAS A CINTA

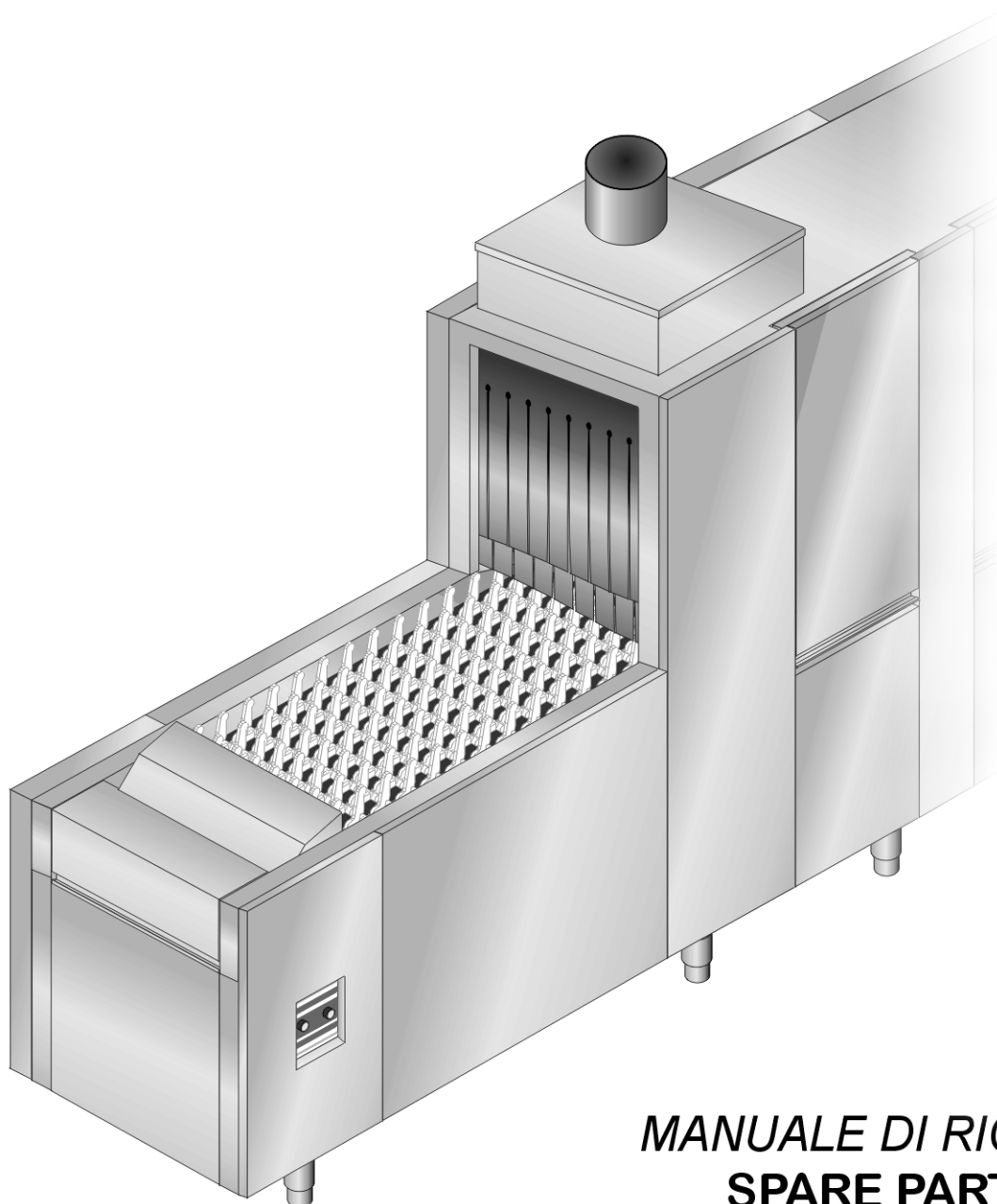

**N
3
5
0
0**

MANUALE DI RICAMBI
SPARE PARTS
CATALOGUES PIÉCES
ERSATZTEILEKATALOG
CATÁLOGO DE REPUESTOS

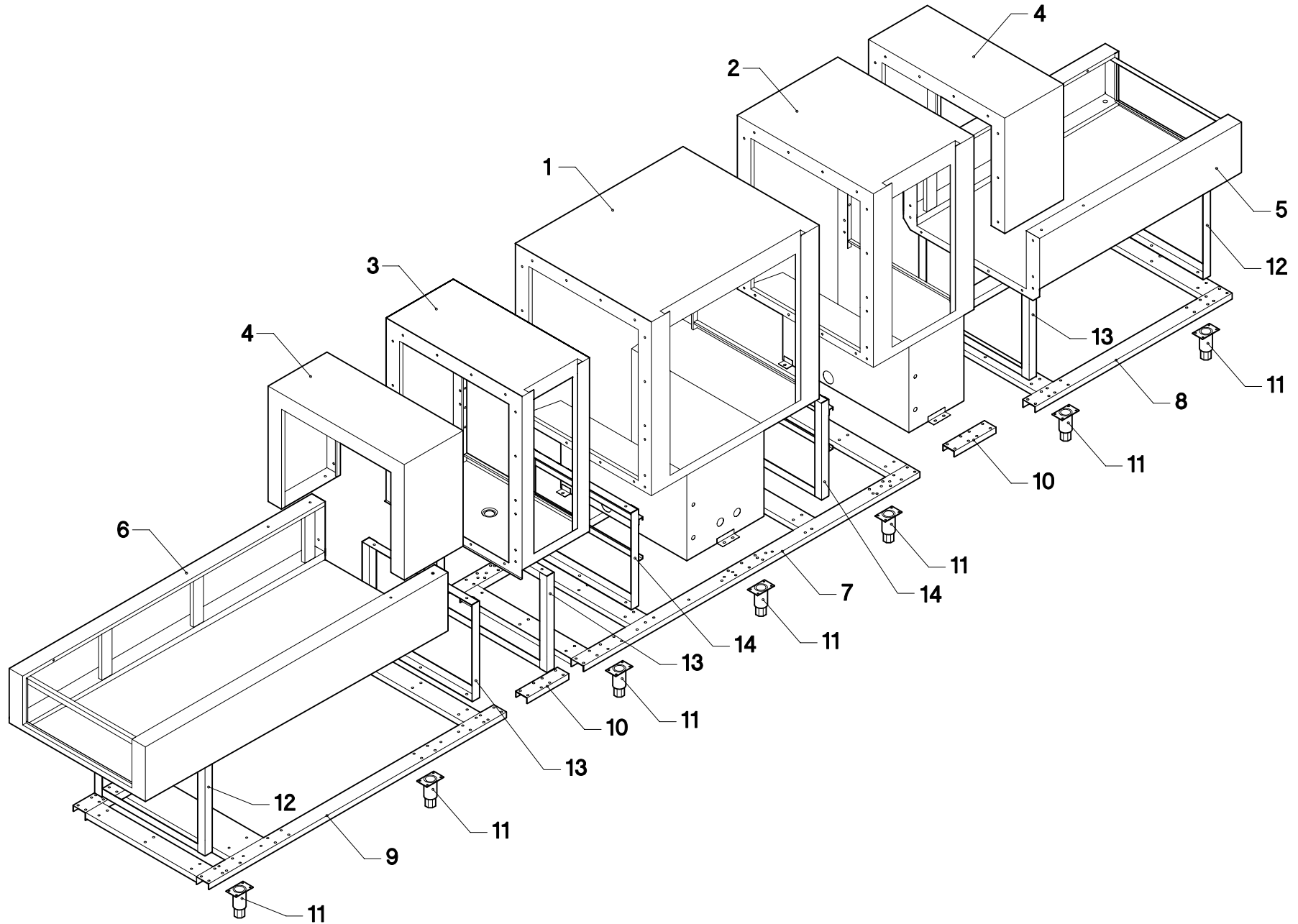

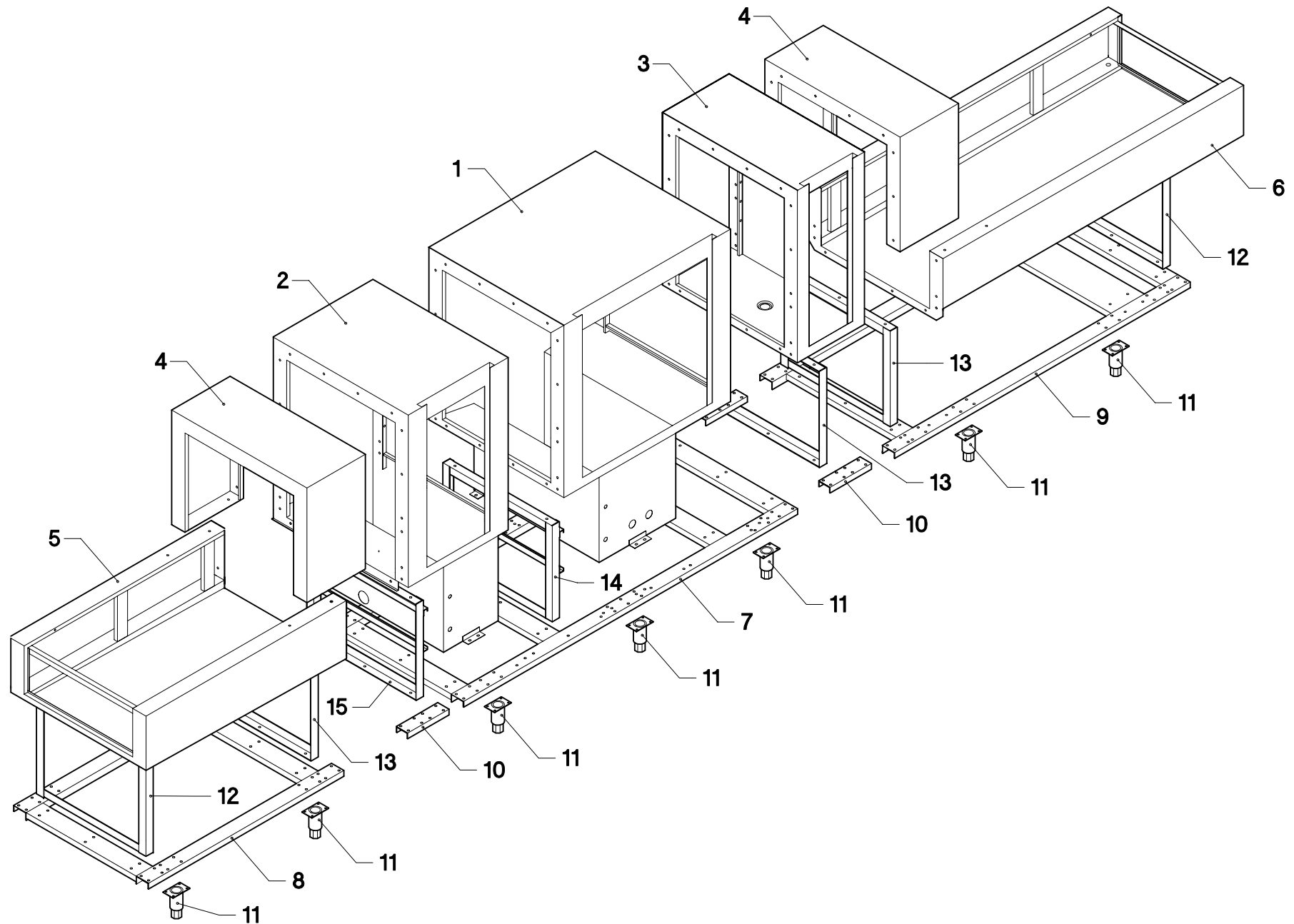

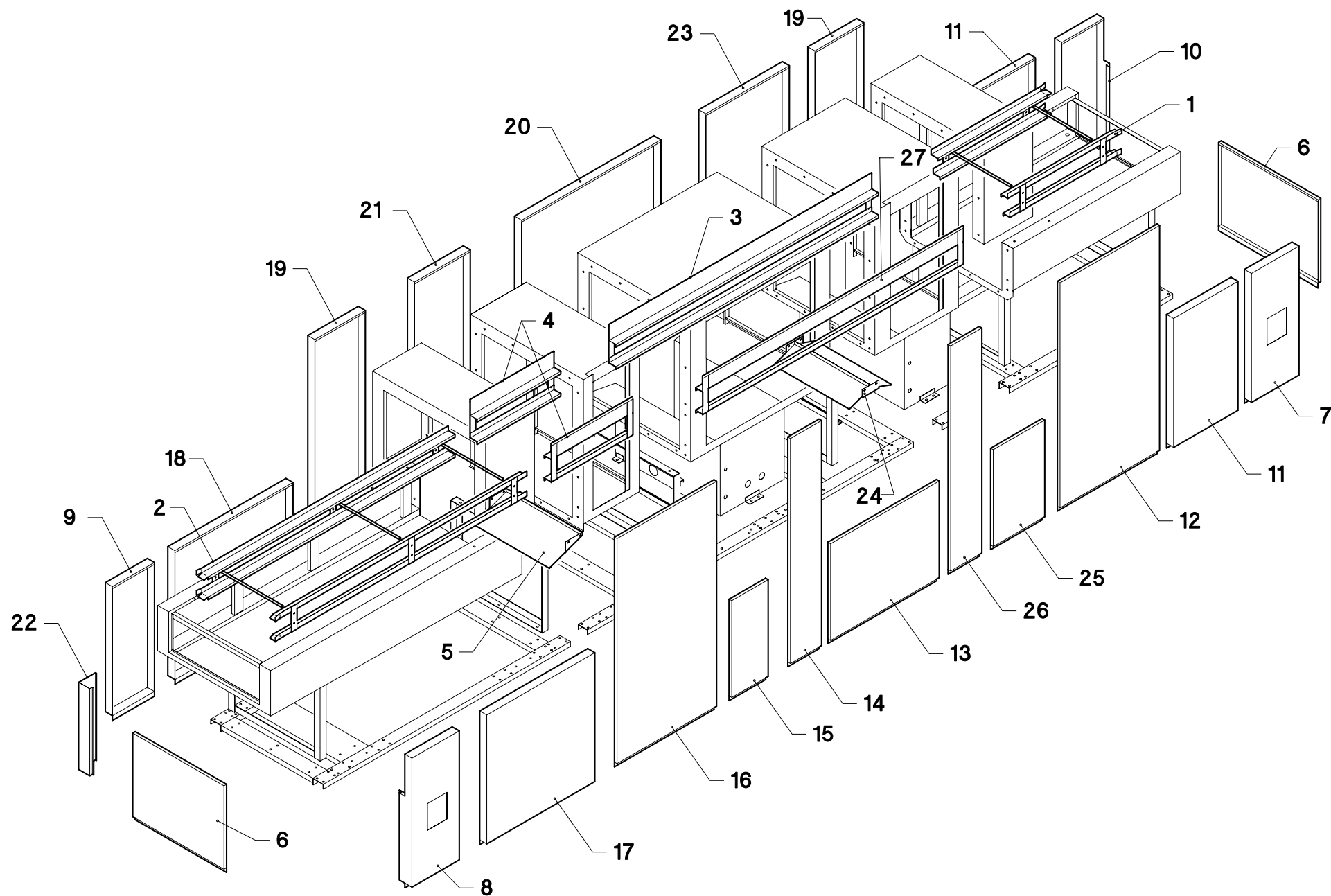

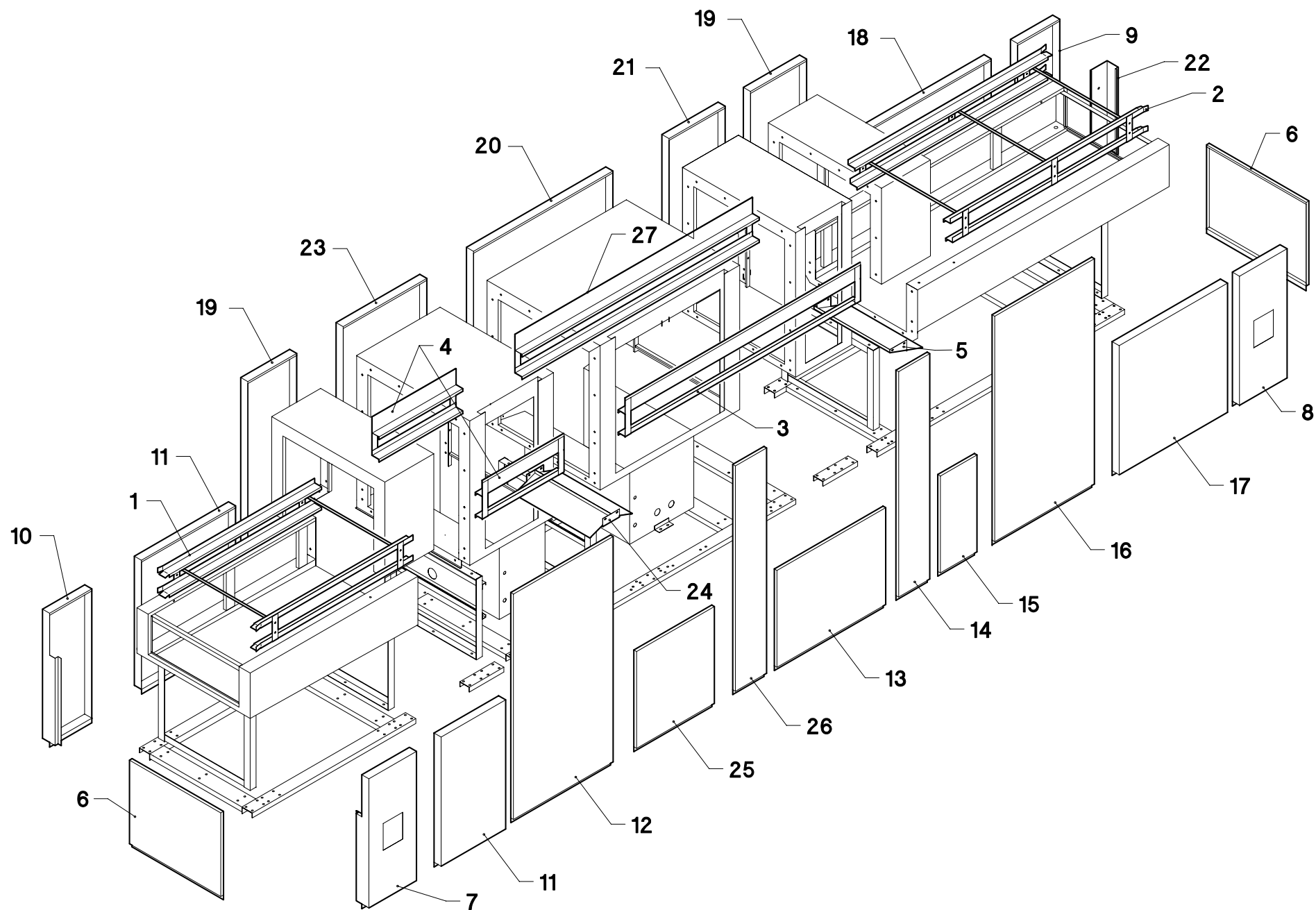

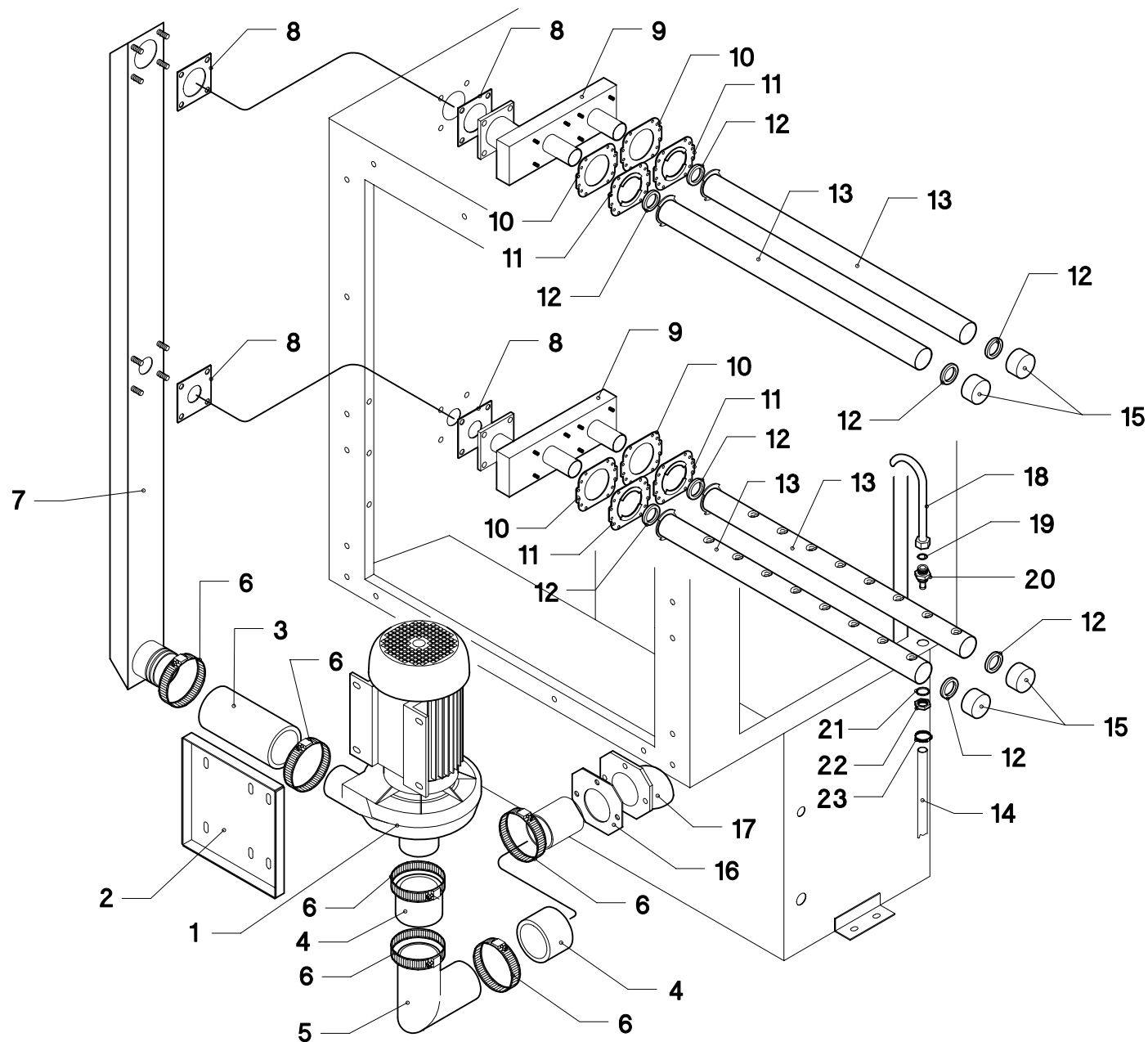

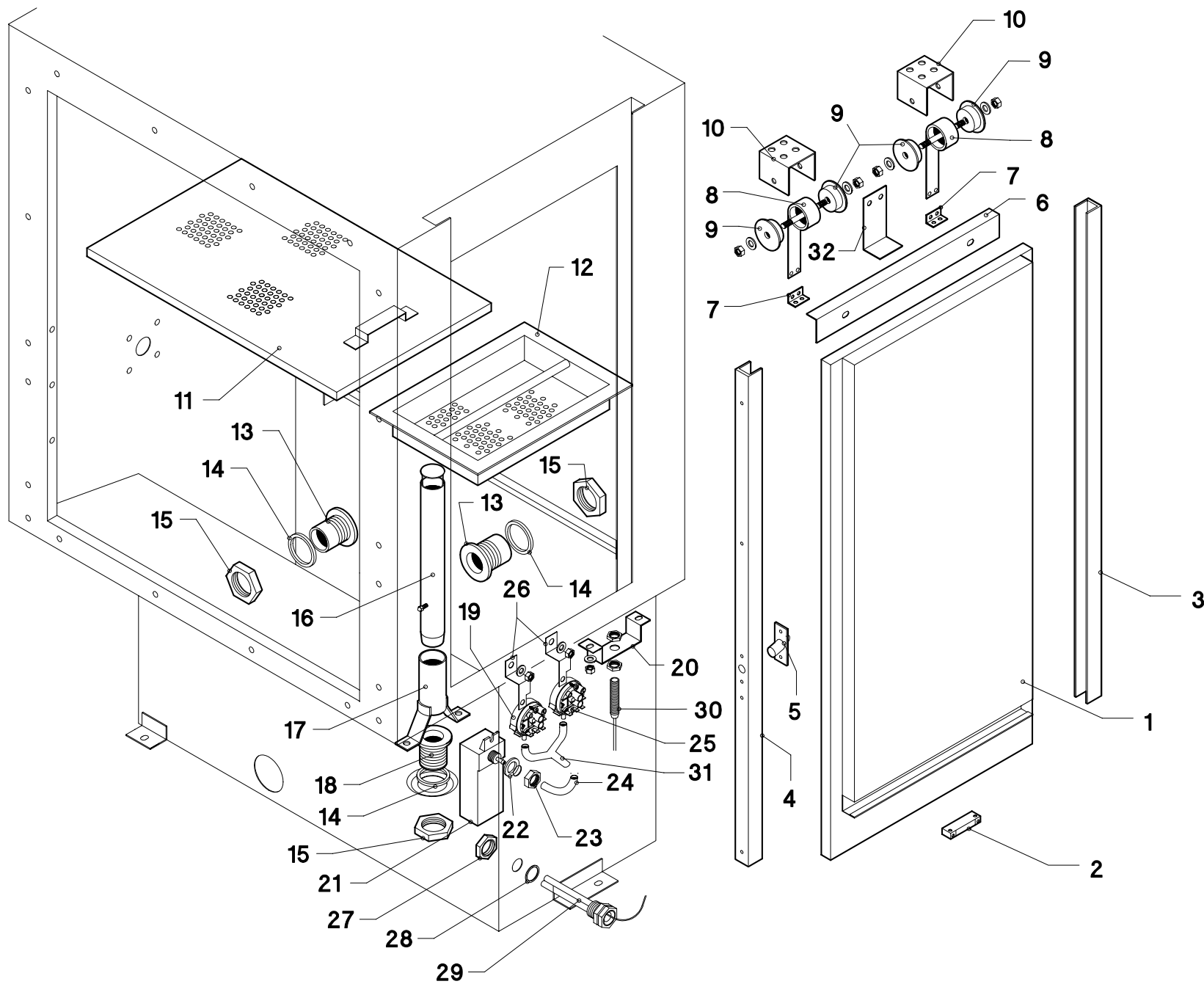

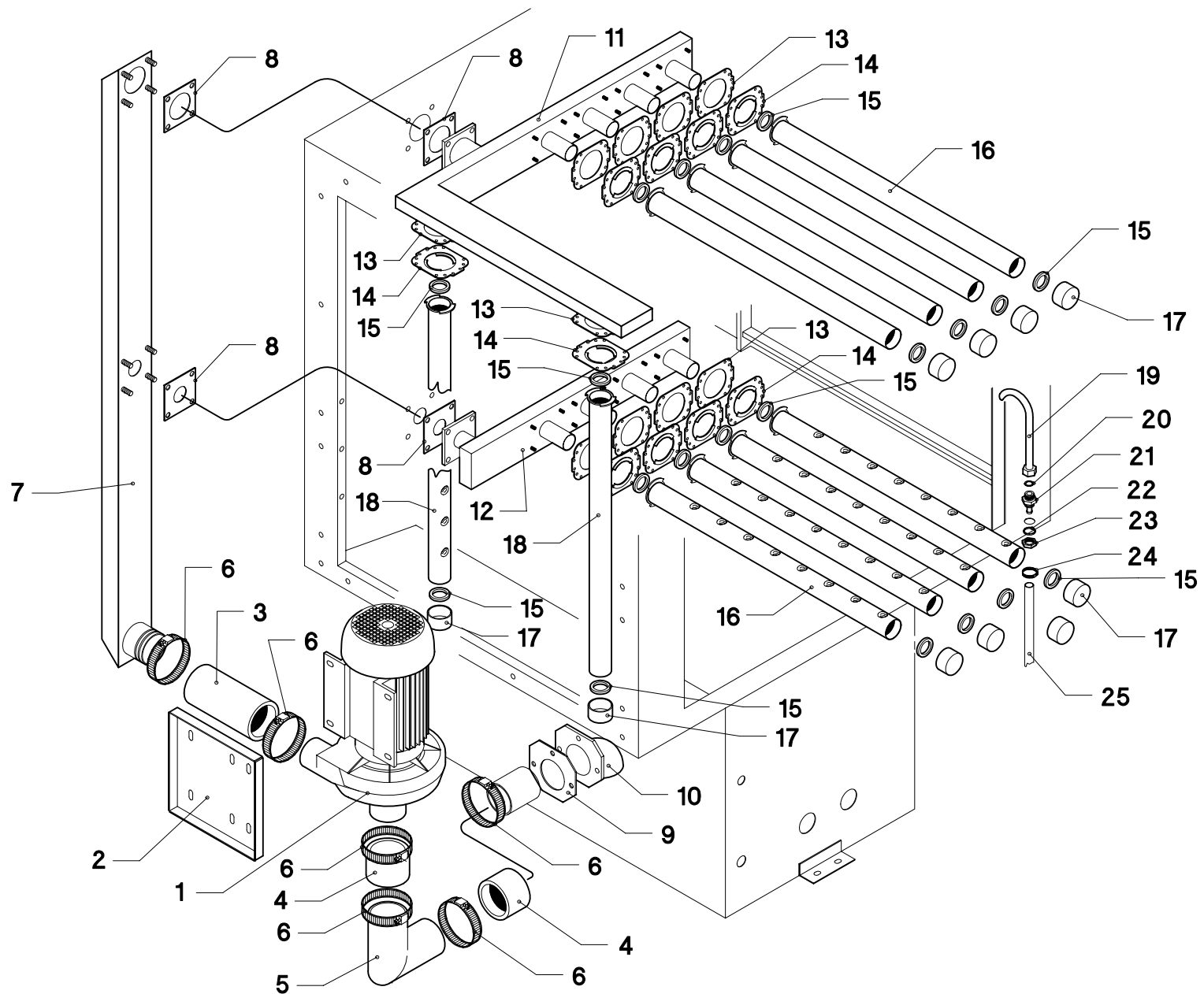

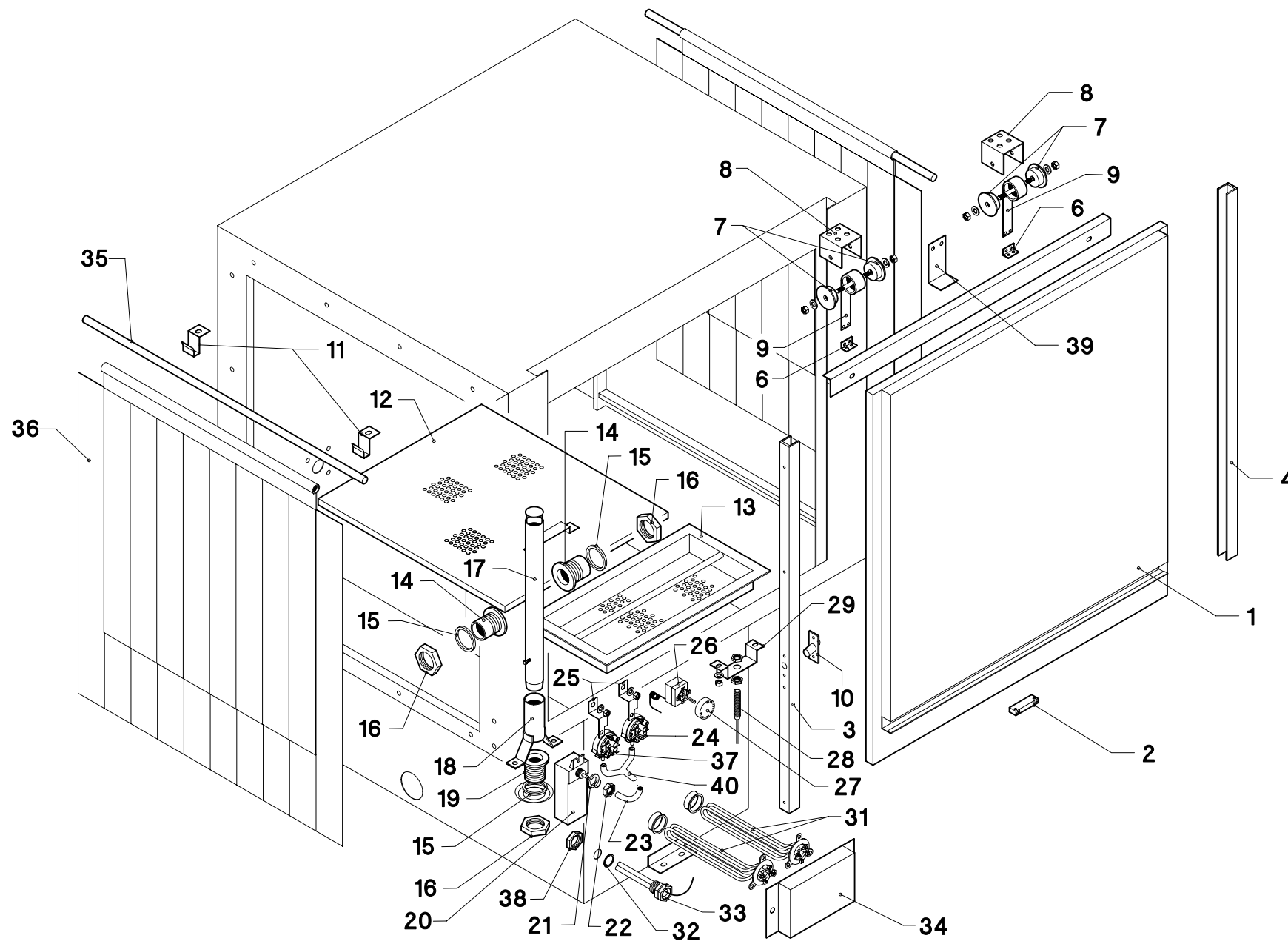

Pos.	COD.	COD.	Q.tà	DESCRIZIONE	DENOMINATION	DESCRIPTION	BEZEICHNUNG	DESCRIPCIÓN
1	TR1008		1	PORTA	PORTE	DOOR	TÜR	PUERTA
2	TR0220		1	CUSTODIA CON MAGNETE	PROTECTION MAGNETO	COVER MAGNET	MAGNETSCHUTZ	ESTUCHE CON IMAN
3	TR1102		1	GUIDA SCORRIMENTO SX	RAIL SX	GUIDE SX	FÜHRUNG SX	GUIA DESLIZAMENTO SX
4	TR1083		1	GUIDA SCORRIMENTO DX	RAIL DX	GUIDE DX	FÜHRUNG DX	GUIA DESLIZAMENTO DX
5	TR2005		1	PARASPRUZZI	GARDE-JETS	SPRAY-GUARD	SPRITZBLECH	SALPICADERO
6	TR0607		2	AGGANCIO MOLLA	CROCHET RESSORT	SPRING HOOKING	KUPPLUNGFEDER	ENGANCHE RESORTE
7	TR0999		4	SUPP. SCORRIMENTO MOLLA	SUPPORT POUR RESSORT	SPRING SUPPORT	FEDER TRÄGER	SOP. DESLIZAMIENTO RESORTE
8	TR2008		2	SQUADR. FISSAGGIO MOLLA	EQUERRE POUR RESSORT	SPRING SUPPORT	FEDER TRÄGER	ANGULAR FIJADORESORTE
9	TR1856		2	MOLLA PORTA LAVAGGIO	RESSORT	SPRING	FEDER	RESORTE PUERTA LAV.
10	TR0620		1	BLOCCO SICUREZZA PORTA	BLOC DE SÉCURITÉ	SAFETY DOOR CATCH	BLOCK TÜR	BLOQUEO DE SEGUR. PUERTA
11	TR2162		2	SQUADRETTA TENDINA	EQUERRE RIDEAU	BRACKET CURTAIN	WINKEL SPRITZSCHUTZ	ANGULAR CORTINILLA
12	TR2207		1	FILTRO	FILTRE	FILTRE	FILTER	FILTRO
13	TR2209		1	FILTRO	FILTRE	FILTRE	FILTER	FILTRO
14	905450		2	RACCORDO 1" ¼	RACCORD	PIPE FITTING	ABLAUFANSCHLUSS	EMPALME
15	904380		3	O-RING	O-RING	O-RING	O-RING	O-RING
16	902080		3	GHIERA 1" ¼	VIROLE	LOCK NUT	NUT MUTTER	ABRAZADERA
17	TR1115		1	TROPPOPIENO	NIVEAU	OVER FLOW	UBERLAUFROHR	DEMASIADOLLENO
18	TR0464		1	GUIDA TROPPOPIENO	COULISSE NIVEAU	OVER FLOW GUIDE	UBERLAUFROHR KORB	GUIA DEMASIADOLLENO
19	TR1234		1	RACCORDO 1" ¼	RACCORD	PIPE FITTING	ABLAUFANSCHLUSS	EMPALME
20	TR0268		1	TRAPPOLA ARIA	RESERVOIR AIR	AIR TRAP	LUFTFALLE	TRAMPA DEL AIRE
21	903260		1	GUARNIZIONE	JOINT	GASKET	DICHTUNG	GUARNICIÓN
22	902100		1	GHIERA 3/8"	VIROLE	LOCK NUT	NUT MUTTER	ABRAZADERA
23	907272		1	TUBO PRESSOSTATO	TUYAU PRESSOSTAT	PRESSURE SWITCH PIPE	SCHLAUCH	TUBO PRESÓSTATO
24	905275		1	PRESSOSTATO	PRESSOSTAT	PRESSURE SWITCH	DRUCHWAECHTER	PRESÓSTATO
25	906399		2	SQUADRETTA PRESSOSTATO	EQUERRE PRESSOSTAT	PRESSURE SWITCH BRACKET	WINKEL DRUCHWAECHTER	ANGULAR PRESÓSTATO
26	907100		1	TERMOSTATO	THERMOSTAT	THERMOSTAT	THERMOSTAT	TERMÓSTATO
27	903982		1	MANOPOLA	BOUTON	KNOB	KNOPF	EMPUÑADURA
28	TR0309		1	REED MAGNETICO	REED	REED	REED	REED MAGNÉTICO
29	TR1071		1	SQUADRETTA REED	EQUERRE REED	REED BRACKET	WINKEL REED	ANGULAR REED
30	907981		2	O-RING	O-RING	O-RING	O-RING	O-RING
31	905570		2	RESISTENZA 6000W	RESISTANCE	HEATING ELEMENT	HEIZKÖRPER	RESISTENCIA
32	903250		1	GUARNIZIONE	JOINT	GASKET	DICHTUNG	GUARNICIÓN
33	TR0298		1	PORTABULBO	SIÉGE DE BULBE	SEATING BULB	KUGELSITZ	PORTABULBO
34	TR2021		1	COPRIRESISTENZA	PROTECTION RESISTANCE	HEATING COVER	HEIZKÖRPER SCHUTZ	CUBRE RESISTENCIA

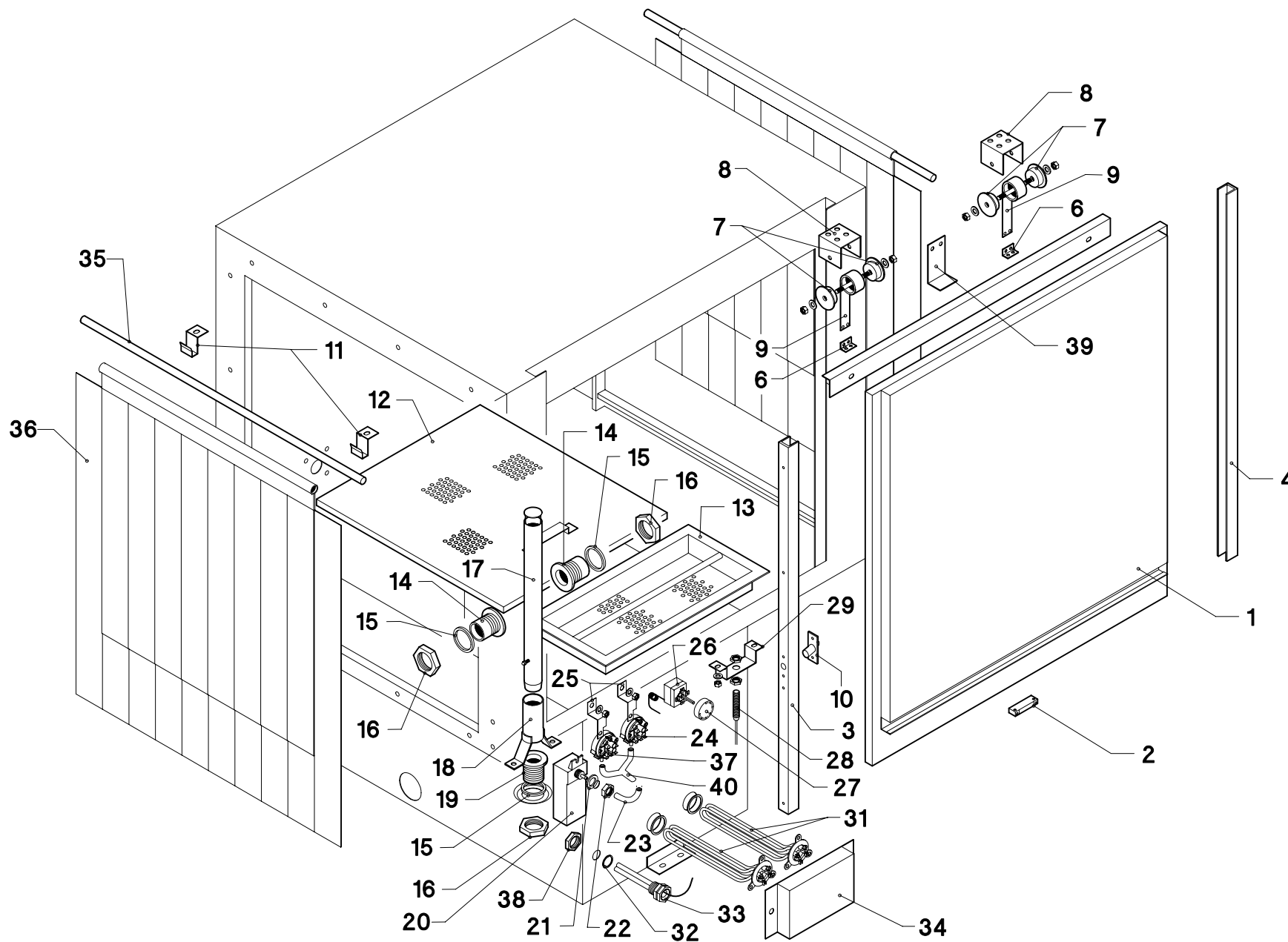

Pos.	COD.	COD.	Q.tà	DESCRIZIONE	DENOMINATION	DESCRIPTION	BEZEICHNUNG	DESCRIPCIÓN
35	TR2034		2	ALBERO PER TENDINA	ARBRE RIDEAU	CURTAIN ROD	HALTERUNG	EJE PARA CORTINILLA
36	TR0471		2	TENDINA	RIDEAU	CURTAIN	SPRITZSCHUTZ	CORTINILLA
37	905270		1	PRESSOSTATO	PRESSOSTAT	PRESSURE SWITCH	DRUCHWAECHTER	PRESÓSTATO
38	902061		1	GHIERA ½"	VIROLE	LOCK NUT	NUT MUTTER	ABRAZADERA
39	TR2185		1	FERMO PORTA	ARRET DE PORTE	SPRING LOCK	FEST TÜR	TOPE PUERTA
40	905423		1	RACCORDO A "Y"	RACCORD	PIPE FITTING	ABLAUFANSCHLUSS	EMPALME

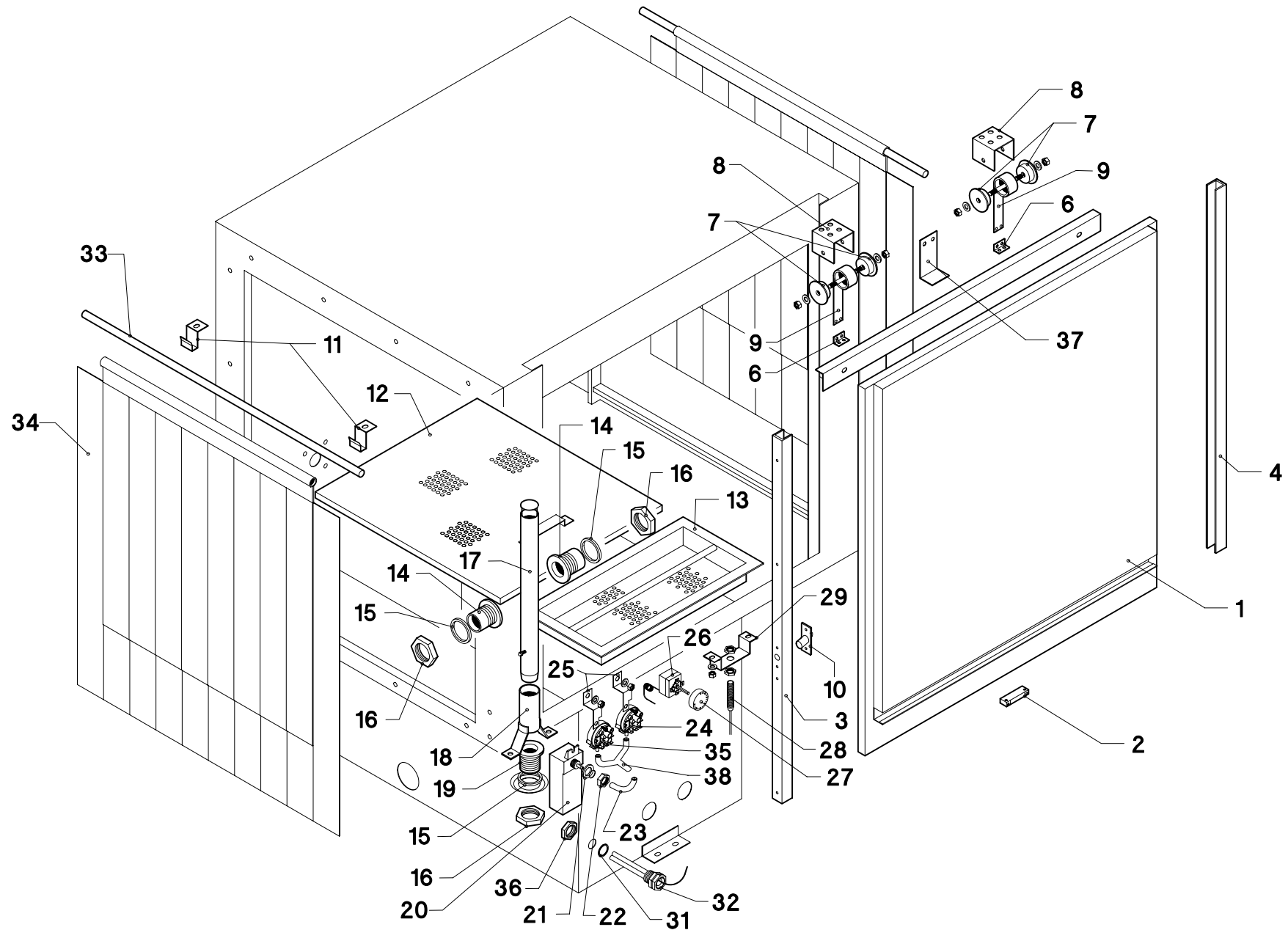

Pos.	COD.	COD.	Q.tà	DESCRIZIONE	DENOMINATION	DESCRIPTION	BEZEICHNUNG	DESCRIPCIÓN
1	TR1008		1	PORTA	PORTE	DOOR	TÜR	PUERTA
2	TR0220		1	CUSTODIA CON MAGNETE	PROTECTION MAGNETO	COVER MAGNET	MAGNETSCHUTZ	ESTUCHE CON IMAN
3	TR1102		1	GUIDA SCORRIMENTO SX	RAIL SX	GUIDE SX	FÜHRUNG SX	GUIA DESLIZAMENTO SX
4	TR1083		1	GUIDA SCORRIMENTO DX	RAIL DX	GUIDE DX	FÜHRUNG DX	GUIA DESLIZAMENTO DX
5	TR2005		1	PARASPRUZZI	GARDE-JETS	SPRAY-GUARD	SPRITZBLECH	SALPICADERO
6	TR0607		2	AGGANCIO MOLLA	CROCHET RESSORT	SPRING HOOKING	KUPPLUNGFEDER	ENGANCHE RESORTE
7	TR0999		4	SUPP. SCORRIMENTO MOLLA	SUPPORT POUR RESSORT	SPRING SUPPORT	FEDER TRÄGER	SOP. DESLIZAMIENTO RESORTE
8	TR2008		2	SQUADR. FISSAGGIO MOLLA	EQUERRE POUR RESSORT	SPRING SUPPORT	FEDER TRÄGER	ANGULAR FIJADORESORTE
9	TR1856		2	MOLLA PORTA LAVAGGIO	RESSORT	SPRING	FEDER	RESORTE PUERTA LAV.
10	TR0620		1	BLOCCO SICUREZZA PORTA	BLOC DE SÉCURITÉ	SAFETY DOOR CATCH	BLOCK TÜR	BLOQUEO DE SEGUR. PUERTA
11	TR2162		2	SQUADRETTA TENDINA	EQUERRE RIDEAU	BRACKET CURTAIN	WINKEL SPRITZSCHUTZ	ANGULAR CORTINILLA
12	TR2207		1	FILTRO	FILTRE	FILTRE	FILTER	FILTRO
13	TR2209		1	FILTRO	FILTRE	FILTRE	FILTER	FILTRO
14	905450		2	RACCORDO 1" ¼	RACCORD	PIPE FITTING	ABLAUFANSCHLUSS	EMPALME
15	904380		3	O-RING	O-RING	O-RING	O-RING	O-RING
16	902080		3	GHIERA 1" ¼	VIROLE	LOCK NUT	NUT MUTTER	ABRAZADERA
17	TR1115		1	TROPPOPIENO	NIVEAU	OVER FLOW	UBERLAUFROHR	DEMASIADOLLENO
18	TR0464		1	GUIDA TROPPOPIENO	COULISSE NIVEAU	OVER FLOW GUIDE	UBERLAUFROHR KORB	GUIA DEMASIADOLLENO
19	TR1234		1	RACCORDO 1" ¼	RACCORD	PIPE FITTING	ABLAUFANSCHLUSS	EMPALME
20	TR0268		1	TRAPPOLA ARIA	RESERVOIR AIR	AIR TRAP	LUFTFALLE	TRAMPA DEL AIRE
21	903260		1	GUARNIZIONE	JOINT	GASKET	DICHTUNG	GUARNICIÓN
22	902100		1	GHIERA 3/8"	VIROLE	LOCK NUT	NUT MUTTER	ABRAZADERA
23	907272		1	TUBO PRESSOSTATO	TUYAU PRESSOSTAT	PRESSURE SWITCH PIPE	SCHLAUCH	TUBO PRESÓSTATO
24	905275		1	PRESSOSTATO	PRESSOSTAT	PRESSURE SWITCH	DRUCHWAECHTER	PRESÓSTATO
25	906399		2	SQUADRETTA PRESSOSTATO	EQUERRE PRESSOSTAT	PRESSURE SWITCH BRACKET	WINKEL DRUCHWAECHTER	ANGULAR PRESÓSTATO
26	907100		1	TERMOSTATO	THERMOSTAT	THERMOSTAT	THERMOSTAT	TERMÓSTATO
27	903982		1	MANOPOLA	BOUTON	KNOB	KNOPF	EMPUÑADURA
28	TR0309		1	REED MAGNETICO	REED	REED	REED	REED MAGNÉTICO
29	TR1071		1	SQUADRETTA REED	EQUERRE REED	REED BRACKET	WINKEL REED	ANGULAR REED
30	907981		2	O-RING	O-RING	O-RING	O-RING	O-RING
31	903250		1	GUARNIZIONE	JOINT	GASKET	DICHTUNG	GUARNICIÓN
32	TR0298		1	PORTABULBO	SIÉGE DE BULBE	SEATING BULB	KUGELSITZ	PORTABULBO
33	TR2034		2	ALBERO PER TENDINA	ARBRE RIDEAU	CURTAIN ROD	HALTERUNG	EJE PARA CORTINILLA
34	TR0471		2	TENDINA	RIDEAU	CURTAIN	SPRITZSCHUTZ	CORTINILLA

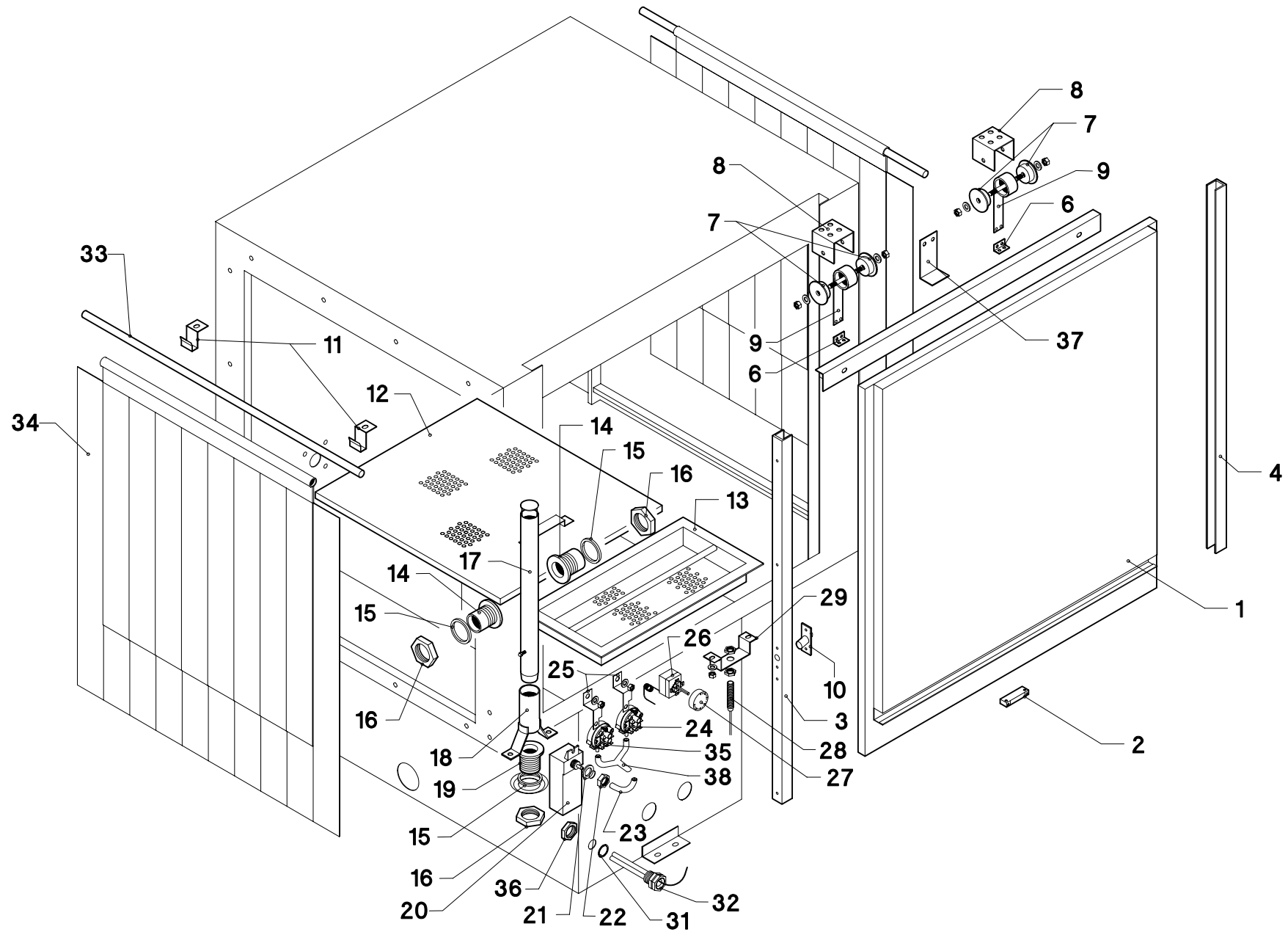

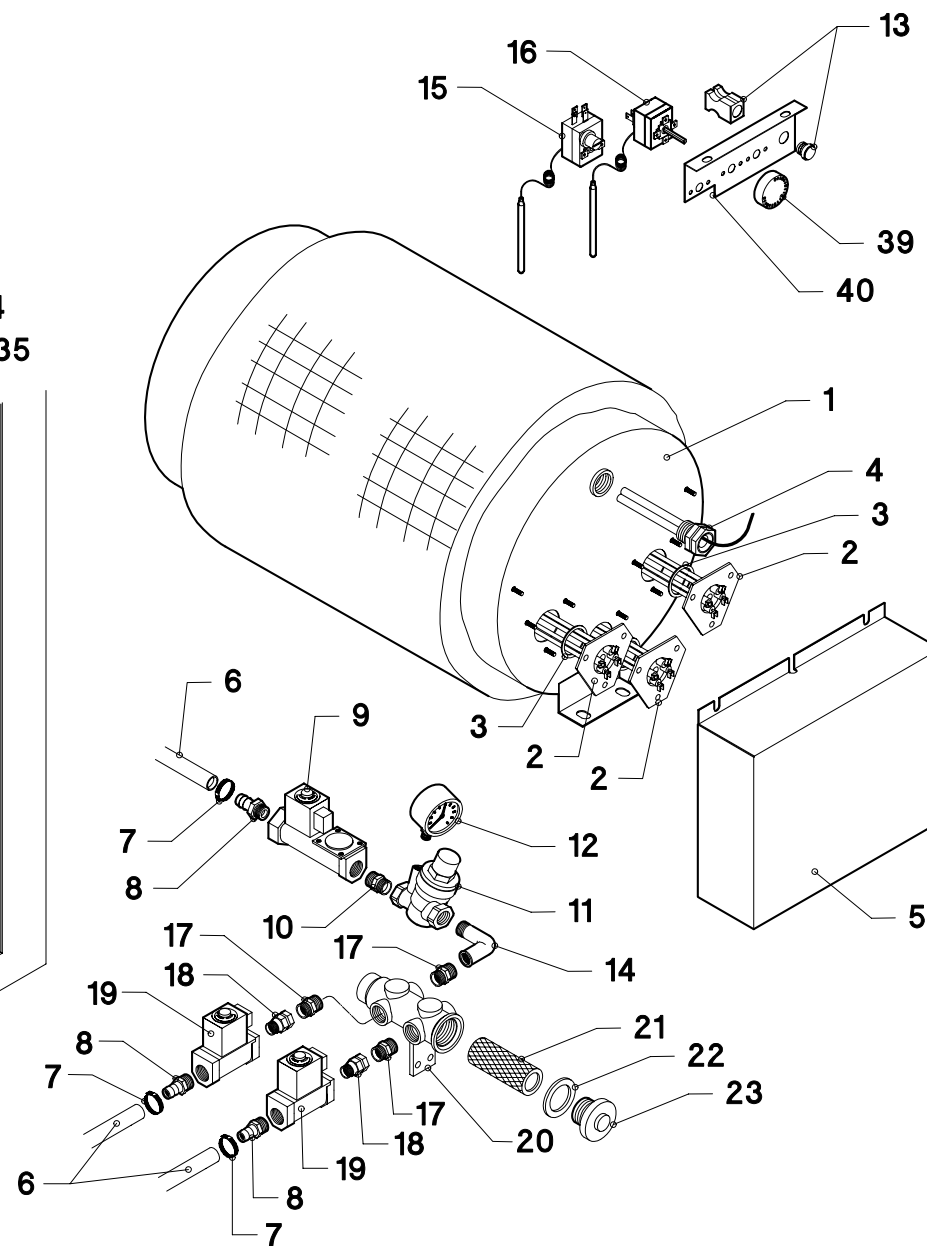
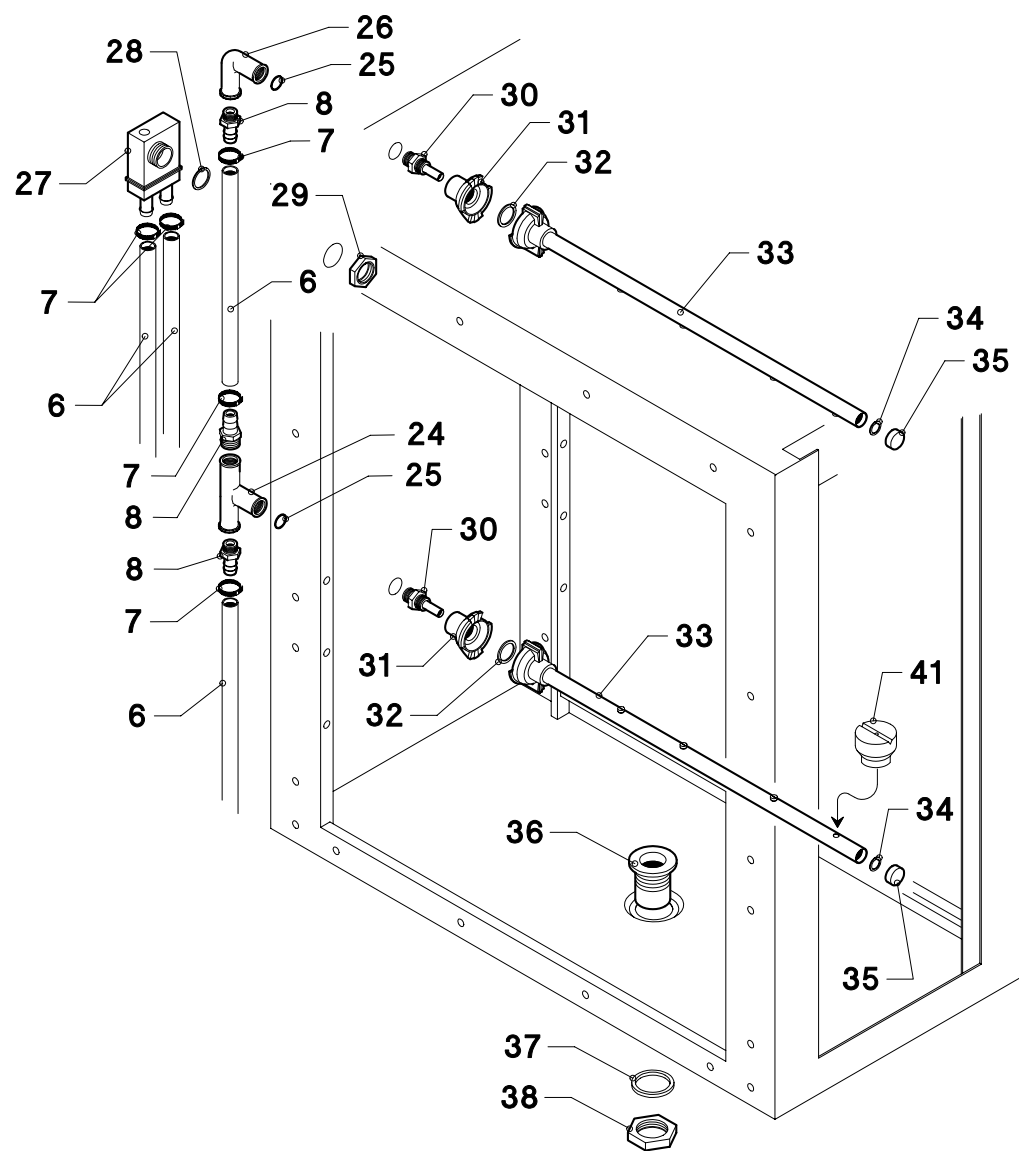

LAVASTOVIGLIE A NASTRO - RISCIAQUO

ED. 2000

TAV. 9

Pos.	COD.	COD.	Q.tà	DESCRIZIONE	DENOMINATION	DESCRIPTION	BEZEICHNUNG	DESCRIPCIÓN
1	TR0029		1	BOILER	CHAUFFE EAU	BOILER	HEISSWASSERSPEICHER	BOILER
2	TR0341		3	RESISTENZA 9000W	RESISTANCE	HEATING ELEMENT	HEIZKÖRPER	RESISTENCIA
3	907981		3	O-RING	O-RING	O-RING	O-RING	O-RING
4	TR0298		1	PORTABULBO	SIÈGE DE BULBE	SEATING BULB	KUGELSITZ	PORTABULBO
5	TR0068		1	COPRIRESISTENZA	PROTECTION RESISTANCE	HEATING COVER	HEIZKÖRPER SCHUTZ	CUBRE RESISTENCIA
6	907350		7	TUBO GOMMA 12X22	TUYAU EN CAOUTCHOUC	RUBBER PIPE	GUMMISCHLAUCH	TUBO GOMA
7	902450		8	FASCETTA 15÷24	COLLIER	CLAMP	SCHELLE	ABRAZADERA
8	TR2375		6	RACCORDO PORTAGOMMA ¾"	RACCORD	PIPE FITTING	ANSCHLUSSE	EMPALME GOME PARA PUERTA
9	TR0090		1	ELETTROVALVOLA ¾"	ELECTROVANNE	ELECTRIC VALVE	ELEKTROVENTIL	VALVULA ELECTRICA
10	TR2347		1	NIPPLO RIDOTTO ½"÷¾"	NIPPLES	NIPPLE	NIPPLE	NIPLE REDUCCIÓN
11	TR0371		1	RIDUTTORE DI PRESSIONE	REDUCTEUR	PRESSURE REDUCER	DRUCKMINDERER	REDUCTOR DE PRECIÓN
12	TR0399		1	MANOMETRO	MANOMETRE REDUCTEUR	PRESSURE GANGE	DRUCK MESSER	MANÓMETRO
13	TR0105		1	PULSANTE RIEMPIMENTO BOILER	BOUTON	PUSH BUTTON	DRUCKTASTE	INTERR. DELLENADO BOILER
14	TR2333		1	BOCCHETTONE CURVO ½"	GOULOTTE	PIPE UNION	STUTZEN	RAMPA DE DESAGÜE CURVO
15	907125		1	TERMOSTATO DI SICUREZZA	THERMOSTAT	THERMOSTAT	THERMOSTAT	TERMÓSTATO DE SEGURIDAD
16	907100		1	TERMOSTATO BOILER	THERMOSTAT	THERMOSTAT	THERMOSTAT	TERMÓSTATO BOILER
17	TR2322		3	NIPPLO ½"	NIPPLES	NIPPLE	NIPPLE	NIPLE
18	TR2335		2	BOCCHETTONE DIRITTO ½"	GOULOTTE	PIPE UNION	STUTZEN	RAMPA DE DESAGÜE RECTO
19	TR0091		2	ELETTROVALVOLA ½"	ELECTROVANNE	ELECTRIC VALVE	ELEKTROVENTIL	VALVULA ELECTRICA
20	TR0127		1	FILTRO 4 VIE	FILTRE	FILTER	FILTER	FILTRO 4 DIRECCIONES
21	TR0123		1	FILTRO A CARTUCCIA	FILTRE	FILTER	FILTER	FILTRO CON CARTUCHO
22	903406		1	GUARNIZIONE	JOINT	GASKET	DICHTUNG	GUARNICIÓN
23	TR2382		1	TAPPO	BOUCHON	PLUG	PROPFFEN	TAPÓN
24	TR2404		1	RACCORDO 3 VIE ½"	RACCORD	PIPE FITTING	ANSCHLUSSE	EMPALME 3 DIRECCIONES
25	904992		2	GUARNIZIONE	JOINT	GASKET	DICHTUNG	GUARNICIÓN
26	TR2437		1	RACCORDO GOMITO ½"	RACCORD	PIPE FITTING	ANSCHLUSSE	EMPALME CODO
27	907460		1	VALVOLA ANTIRITORNO	VALVE	VALVE	VENTIL	VALVULA ANTIREGRESO
28	903290		1	GUARNIZIONE	JOINT	GASKET	DICHTUNG	GUARNICIÓN
29	TR0138		1	GHIERA PG 21	VIROLE	LOCK NUT	NUT MUTTER	ABRAZADERA
30	TR2350		2	GUIDA BRACCIO RISCIAQUO	COULISSE POUR BRAS	GUIDE FOR ARM	EINFÜHRUNG	GUIA DEL BRAZO ENJUAGUE
31	908096		2	RACCORDO RAPIDO	ATELLAGE	QUICK COUPLER	SCHNELLVERSCHLUSS	EMPALME RAPIDO
32	903321		2	GUARNIZIONE	JOINT	GASKET	DICHTUNG	GUARNICIÓN
33	TR0064		2	BRACCIO RISCIAQUO SUP./INF.	BRAS RINÇAGE SUP./INF.	UPPER/LOWER RINSE ARM	OBERER/UNTERER NACHSPÜL.	BRAZO ENJUAGUE SUP./INF.
34	903351		2	GUARNIZIONE	JOINT	GASKET	DICHTUNG	GUARNICIÓN

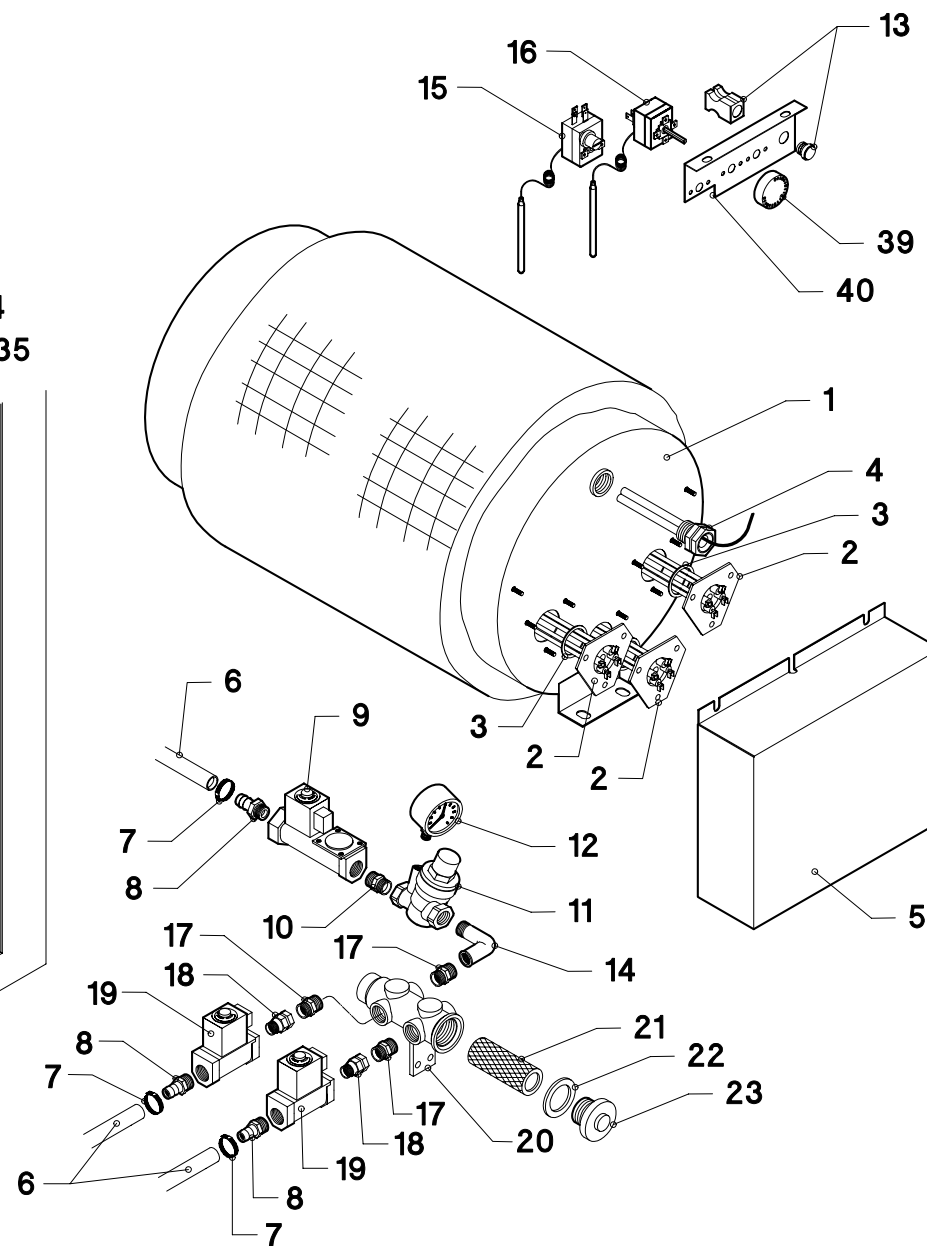
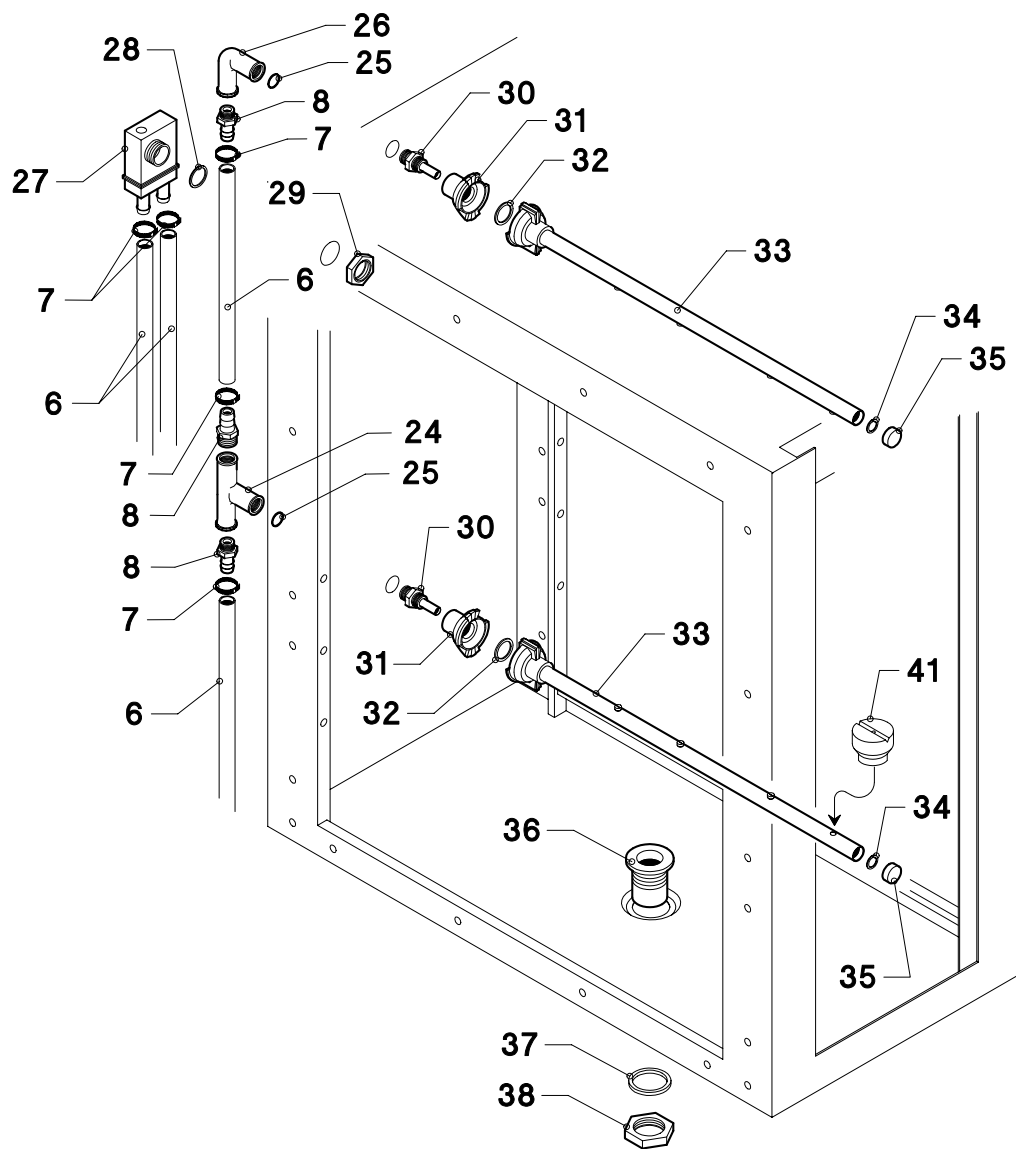

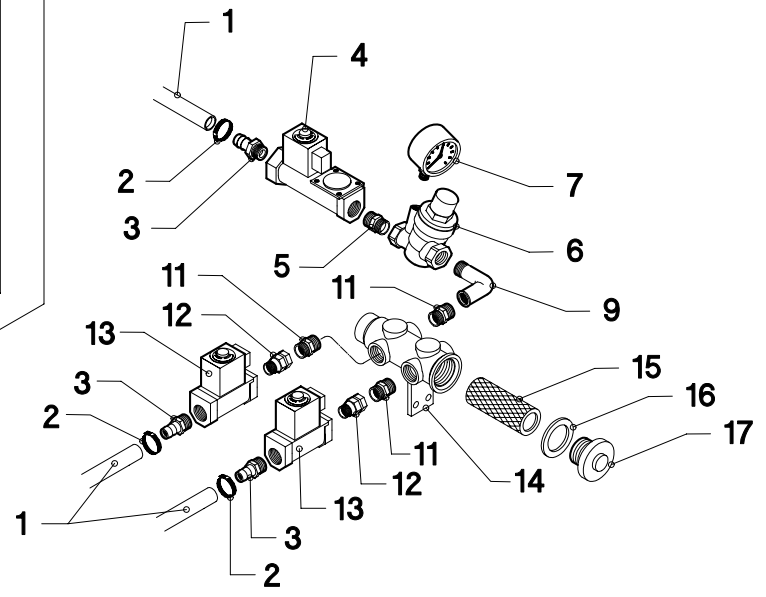
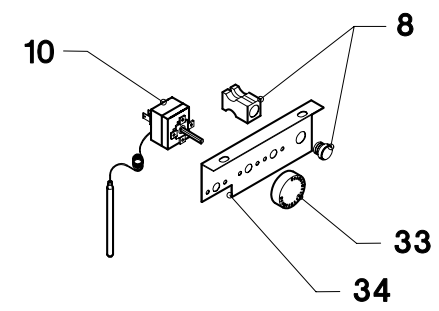
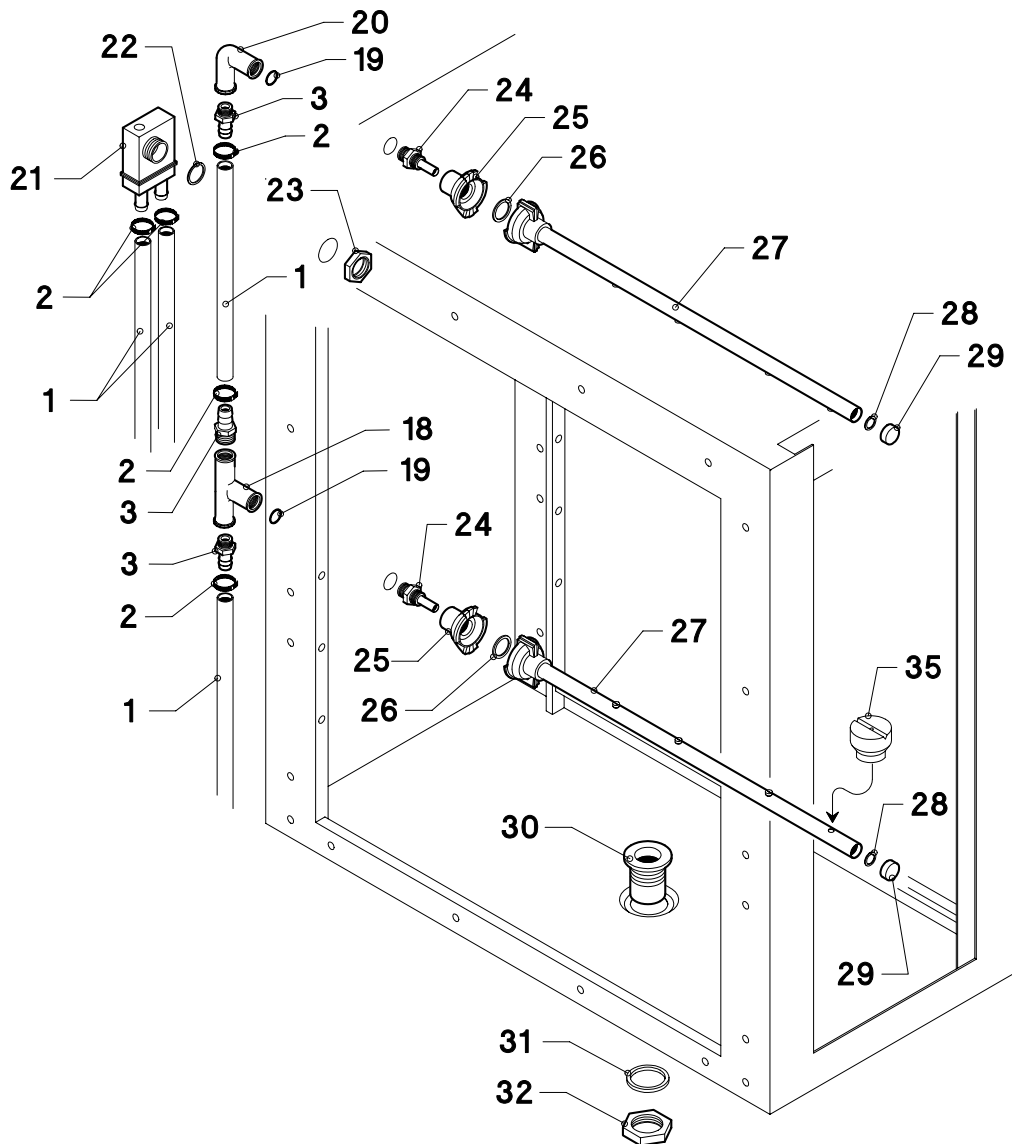

LAVASTOVIGLIE A NASTRO – RISCIAQUO VAPORE

ED. 2000

TAV. 9/1

Pos.	COD.	COD.	Q.tà	DESCRIZIONE	DENOMINATION	DESCRIPTION	BEZEICHNUNG	DESCRIPCIÓN
1	907350		7	TUBO GOMMA 12X22	TUYAU EN CAOUTCHOUC	RUBBER PIPE	GUMMISCHLAUCH	TUBO GOMA
2	902450		8	FASCETTA 15÷24	COLLIER	CLAMP	SCHELLE	ABRAZADERA
3	TR2375		6	RACCORDO PORTAGOMMA ¾"	RACCORD	PIPE FITTING	ANSCHLUSSE	EMPALME GOME PARA PUERTA
4	TR0090		1	ELETTROVALVOLA ¾"	ELECTROVANNE	ELECTRIC VALVE	ELEKTROVENTIL	VALVULA ELECTRICA
5	TR2347		1	NIPPLO RIDOTTO ½"÷¾"	NIPPLES	NIPPLE	NIPPLE	NIPLE REDUCCIÓN
6	TR0371		1	RIDUTTORE DI PRESSIONE	REDUCTEUR	PRESSURE REDUCER	DRUCKMINDERER	REDUCTOR DE PRECIÓN
7	TR0399		1	MANOMETRO	MANOMETRE REDUCTEUR	PRESSURE GANGE	DRUCK MESSER	MANÓMETRO
8	TR0105		1	PULSANTE RIEMPIMENTO BOILER	BOUTON	PUSH BUTTON	DRUCKTASTE	INTERR. DELLENADO BOILER
9	TR2333		1	BOCCHETTONE CURVO ½"	GOULOTTE	PIPE UNION	STUTZEN	RAMPA DE DESAGÜE CURVO
10	907100		1	TERMOSTATO BOILER	THERMOSTAT	THERMOSTAT	THERMOSTAT	TERMÓSTATO BOILER
11	TR2322		3	NIPPLO ½"	NIPPLES	NIPPLE	NIPPLE	NIPLE
12	TR2335		2	BOCCHETTONE DIRITTO ½"	GOULOTTE	PIPE UNION	STUTZEN	RAMPA DE DESAGÜE RECTO
13	TR0091		2	ELETTROVALVOLA ½"	ELECTROVANNE	ELECTRIC VALVE	ELEKTROVENTIL	VALVULA ELECTRICA
14	TR0127		1	FILTRO 4 VIE	FILTRE	FILTER	FILTER	FILTRO 4 DIRECCIONES
15	TR0123		1	FILTRO A CARTUCCIA	FILTRE	FILTER	FILTER	FILTRO CON CARTUCHO
16	903406		1	GUARNIZIONE	JOINT	GASKET	DICHTUNG	GUARNICIÓN
17	TR2382		1	TAPPO	BOUCHON	PLUG	PROPFEN	TAPÓN
18	TR2404		1	RACCORDO 3 VIE ½"	RACCORD	PIPE FITTING	ANSCHLUSSE	EMPALME 3 DIRECCIONES
19	904992		2	GUARNIZIONE	JOINT	GASKET	DICHTUNG	GUARNICIÓN
20	TR2437		1	RACCORDO GOMITO ½"	RACCORD	PIPE FITTING	ANSCHLUSSE	EMPALME CODO
21	907460		1	VALVOLA ANTIRITORNO	VALVE	VALVE	VENTIL	VALVULA ANTIREGRESO
22	903290		1	GUARNIZIONE	JOINT	GASKET	DICHTUNG	GUARNICIÓN
23	TR0138		1	GHIERA PG 21	VIROLE	LOCK NUT	NUT MUTTER	ABRAZADERA
24	TR2350		2	GUIDA BRACCIO RISCIAQUO	COULISSE POUR BRAS	GUIDE FOR ARM	EINFÜHRUNG	GUIA DEL BRAZO ENJUAGUE
25	908096		2	RACCORDO RAPIDO	ATELLAGE	QUICK COUPLER	SCHNELLVERSCHLUSS	EMPALME RAPIDO
26	903321		2	GUARNIZIONE	JOINT	GASKET	DICHTUNG	GUARNICIÓN
27	TR0064		2	BRACCIO RISCIAQUO SUP./INF.	BRAS RINÇAGE SUP./INF.	UPPER/LOWER RINSE ARM	OBERER/UNTERER NACHSPÜL.	BRAZO ENJUAGUE SUP./INF.
28	903351		2	GUARNIZIONE	JOINT	GASKET	DICHTUNG	GUARNICIÓN
29	TR3227		2	TAPPO	BOUCHON	PLUG	PROPFEN	TAPÓN
30	905450		1	RACCORDO 1" ¼	RACCORD	PIPE FITTING	ANSCHLUSSE	EMPALME
31	904380		1	O-RING	O-RING	O-RING	O-RING	O-RING
32	902080		1	GHIERA 1" ¼	VIROLE	LOCK NUT	NUT MUTTER	ABRAZADERA
33	903982		1	MANOPOLA	BOUTON	KNOB	KNOPF	EMPUÑADURA
34	TR2171		1	SQUADRETTA TERMOSTATI	EQUERRE THERMOSTAT	THERMOSTAT BRACKET	WINKEL THERMOSTAT	ANGULAR TERMÓSTATO
35	TR0003		8	GETTO	JET	JET	SPULDUSE	CHORRO

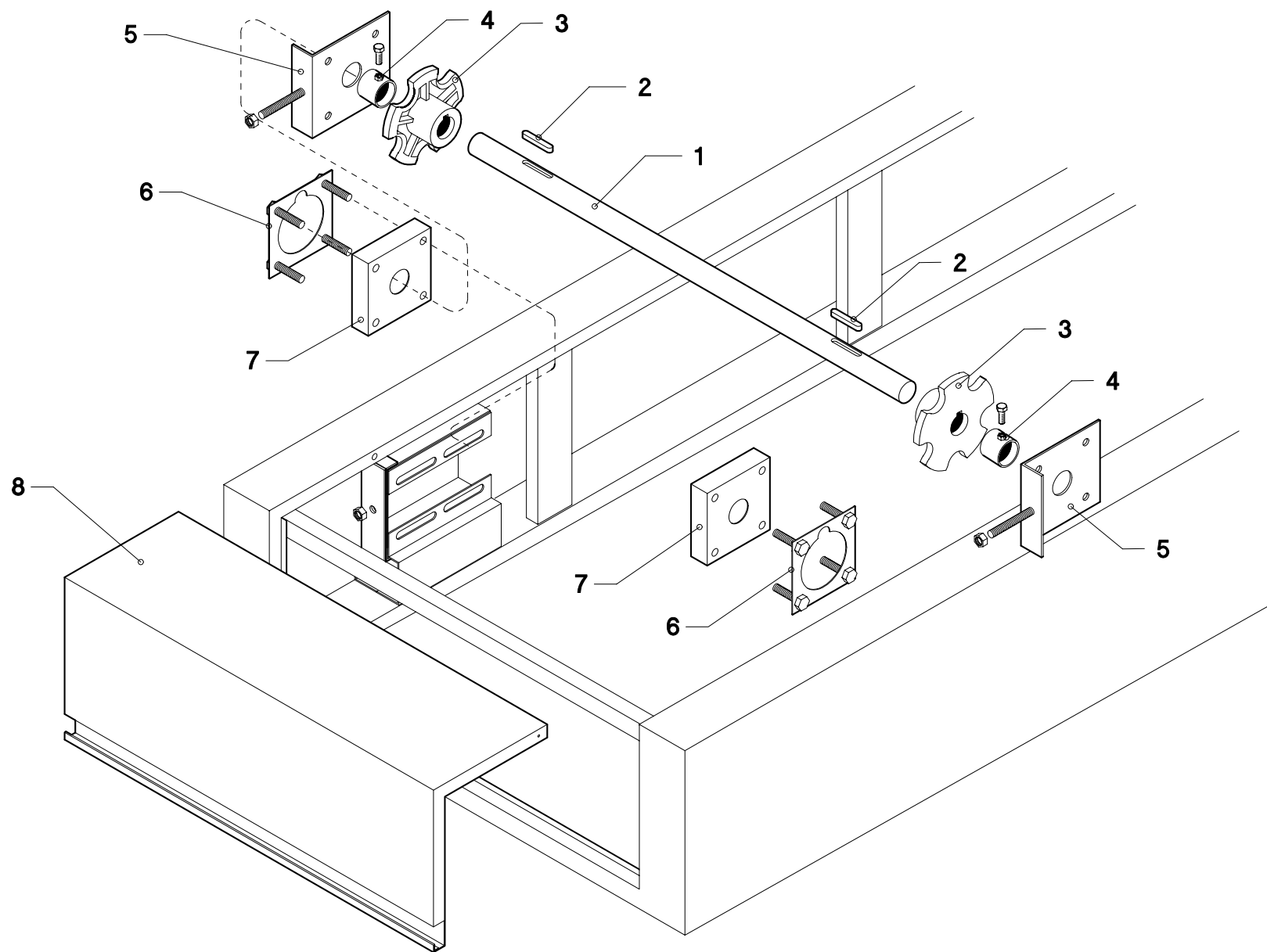

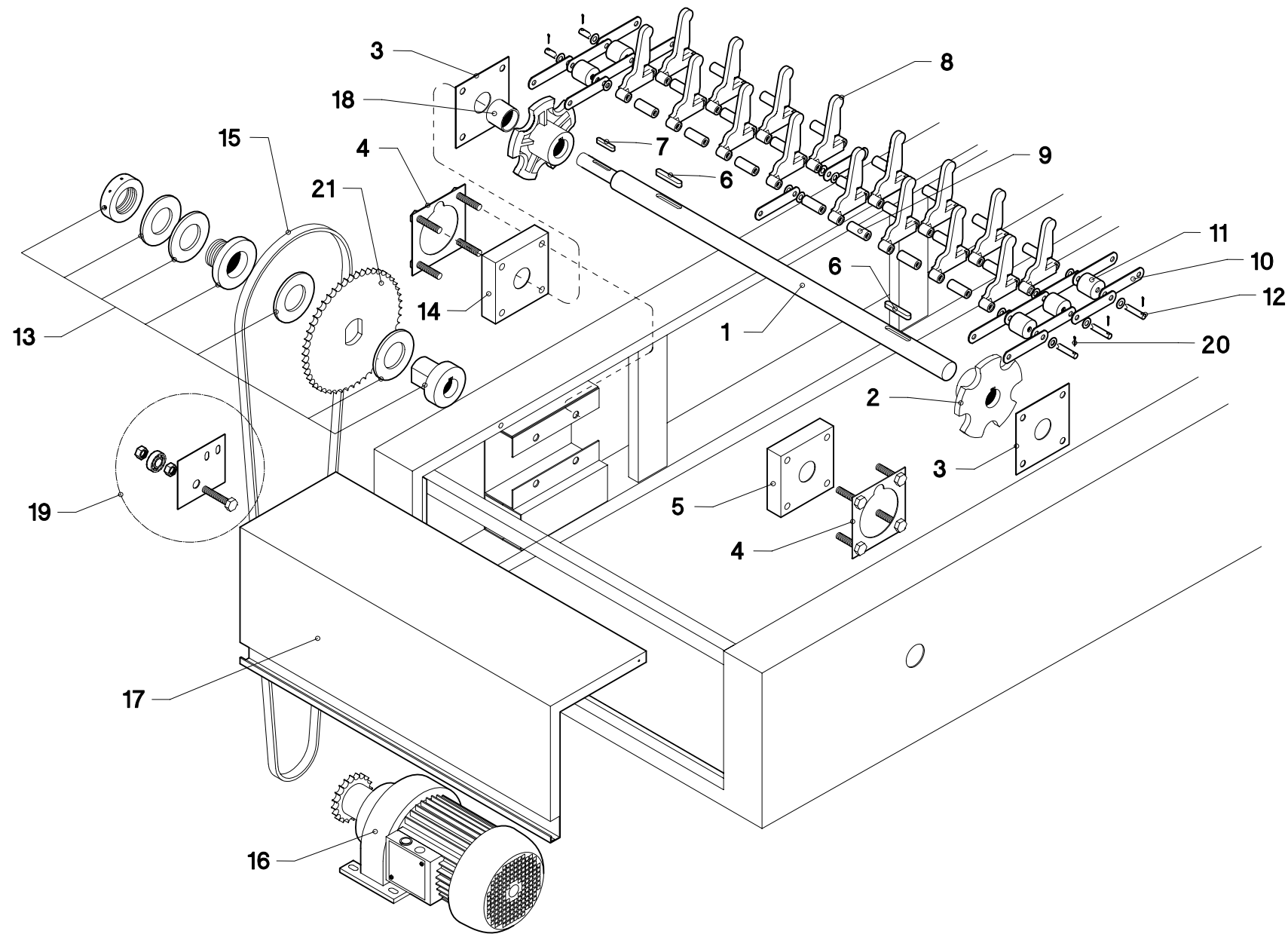

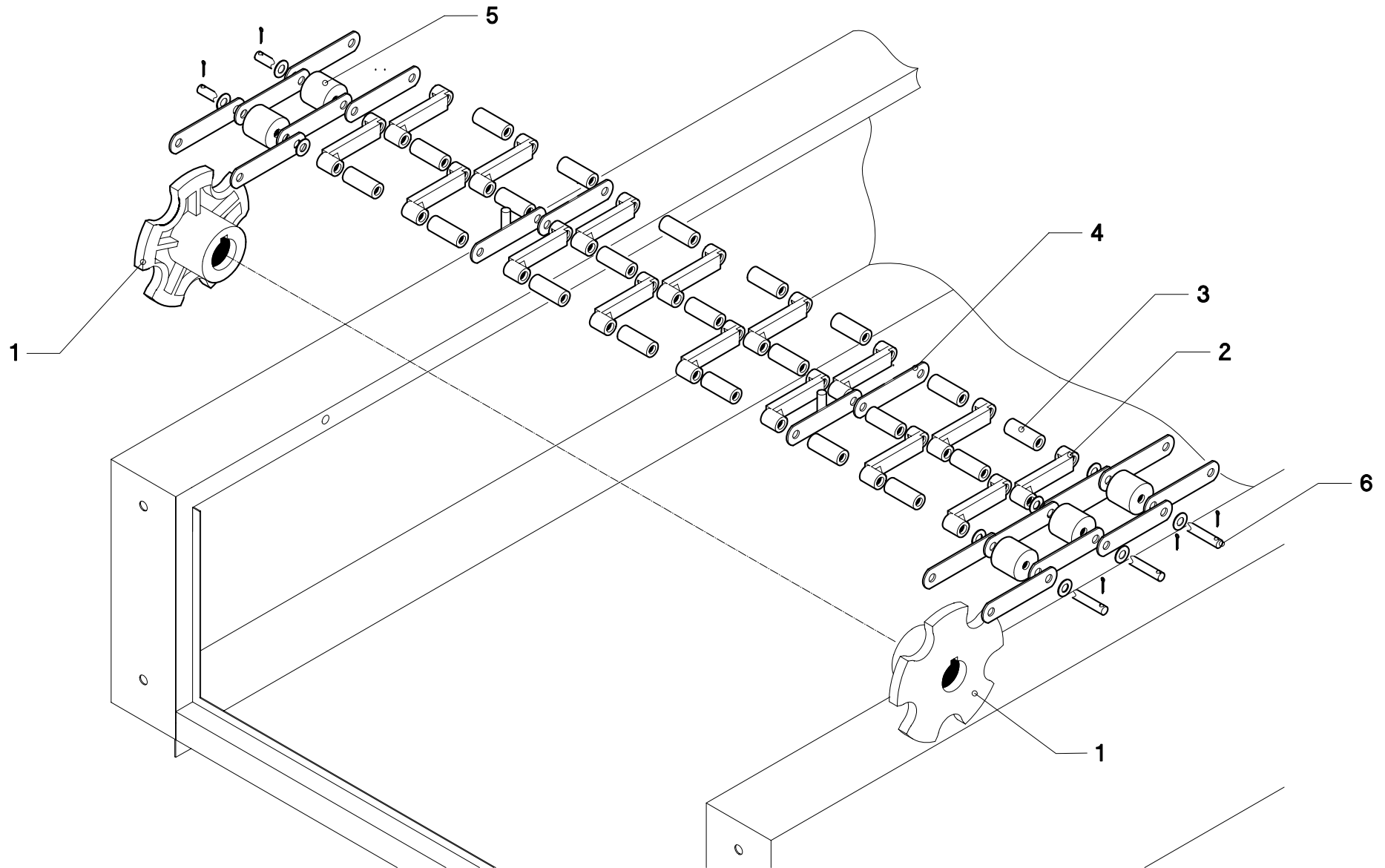

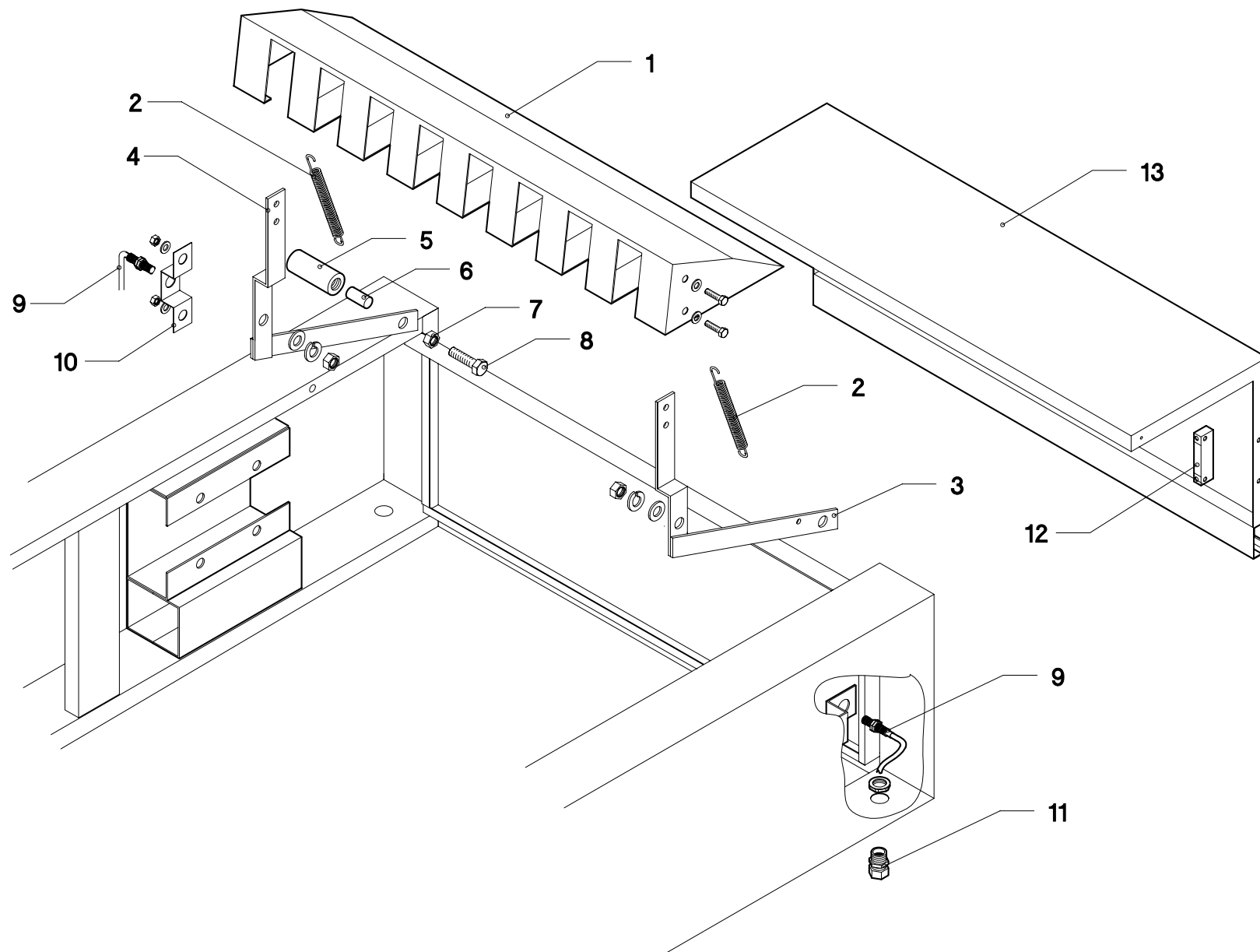

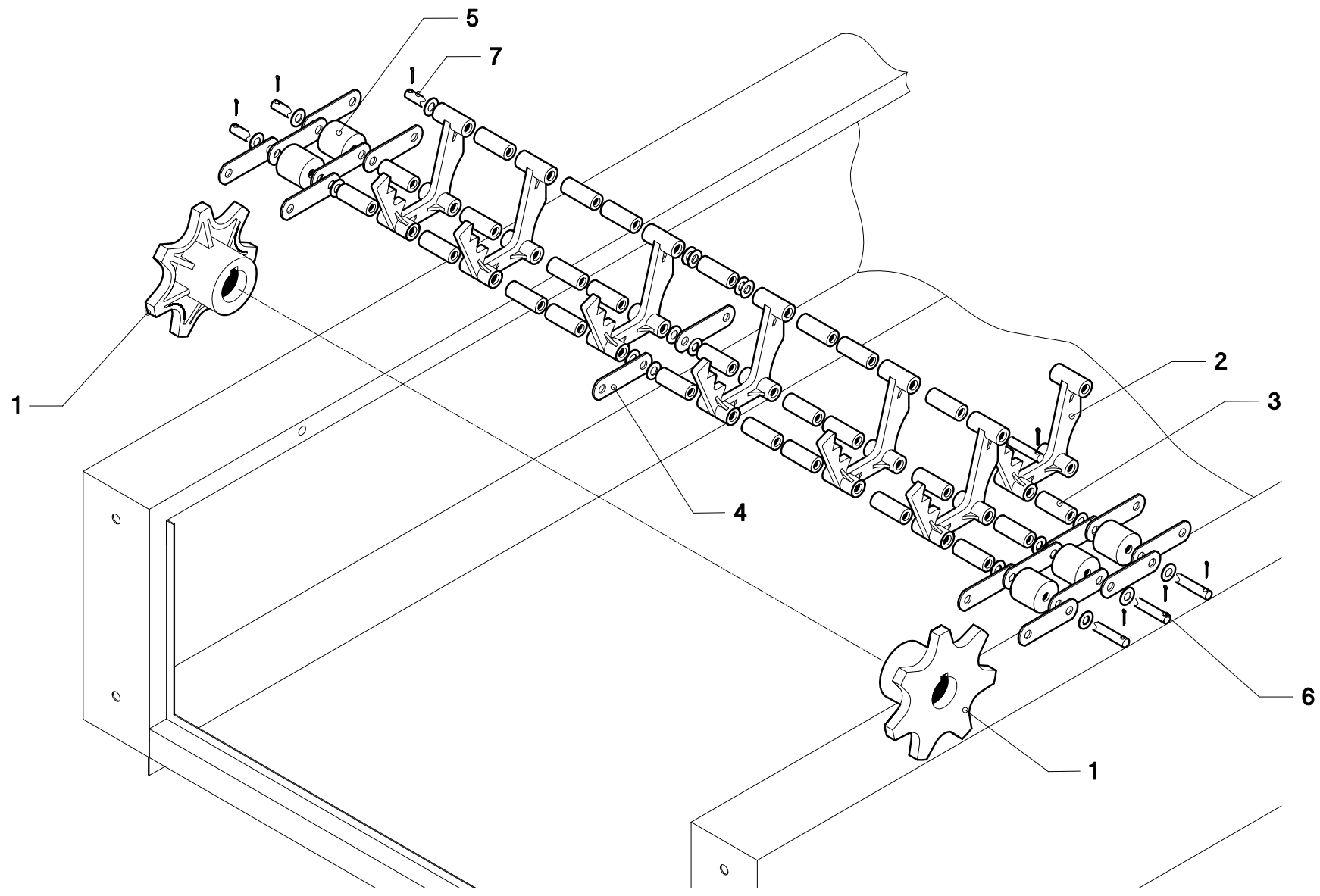

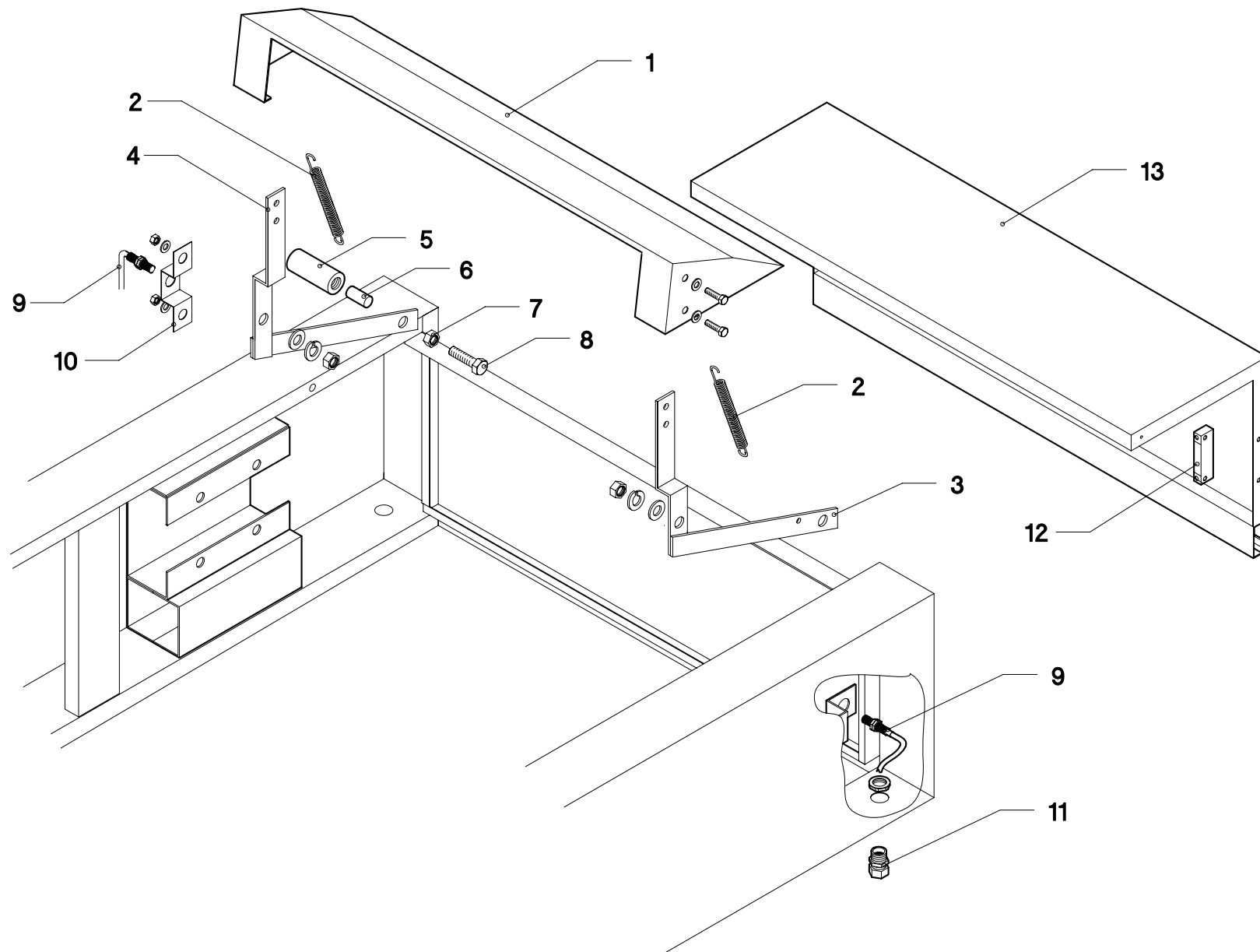

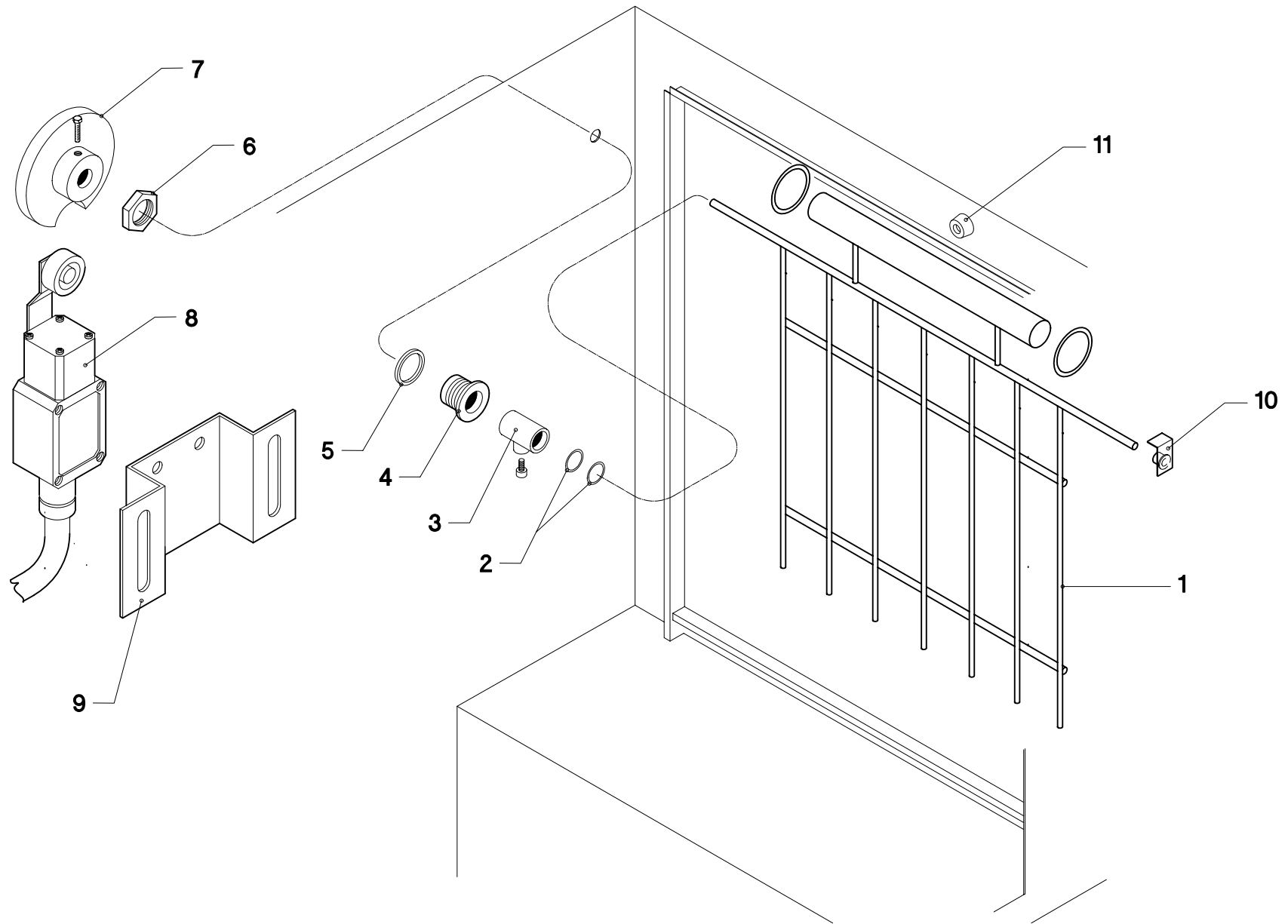

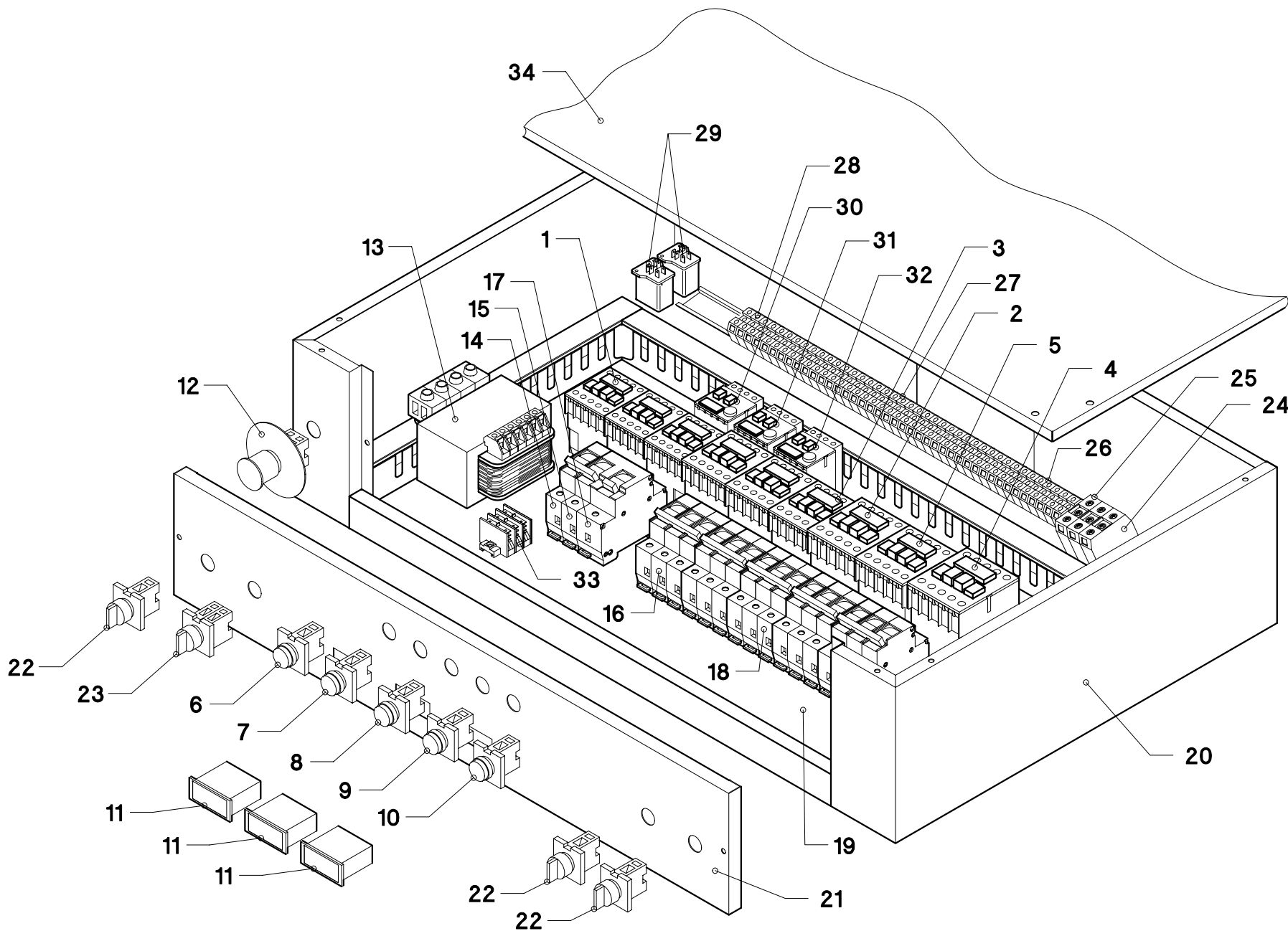

LAVASTOVIGLIE A NASTRO – CASSETTA ELETTRICA N3500

ED. 2000

TAV. 15

Pos.	COD.	COD.	Q.tà	DESCRIZIONE	DENOMINATION	DESCRIPTION	BEZEICHNUNG	DESCRIPCIÓN
1	TR0370		5	TELERUTTORE 9A	TELERUPTEUR	CONTACTOR	SCHUTZ	TELERRUPTOR
2	TR0373		1	TELERUTTORE 18A	TELERUPTEUR	CONTACTOR	SCHUTZ	TELERRUPTOR
3	TR0372		1	TELERUTTORE 9A	TELERUPTEUR	CONTACTOR	SCHUTZ	TELERRUPTOR
4	TR0385		1	TELERUTTORE 40A	TELERUPTEUR	CONTACTOR	SCHUTZ	TELERRUPTOR
5	TR0388		1	TELERUTTORE 32A	TELERUPTEUR	CONTACTOR	SCHUTZ	TELERRUPTOR
6	TR0351		1	PULSANTE D'ARRESTO	BOUTON D'ARRET	STOP PUSH BUTTON	NOTSTOPTASTE	INTERRUPTOR DE DETENCION
7	TR0349		1	PULSANTE DI MARCIA	BOUTON DEMARRAGE	START PUSH BUTTON	ANLASSKNOPF	INTERRUPTOR DE ENCENDIDO
8	TR0284		1	PULSANTE LUMINOSO VERDE	BOUTON VERTE	GREEN PUSH BUTTON	GRUNE DRUCKTASTE	INTERRUPTOR LUZ VERDE
9	TR0287		1	PULSANTE LUMINOSO ROSSO	BOUTON ROUGE	RED PUSH BUTTON	ROTE DRUCKTASTE	INTERRUPTOR LUZ ROJA
10	TR0348		1	PULSANTE LUMINOSO GIALLO	BOUTON JAUNE	YELLOW PUSH BUTTON	GELB DRUCKTASTE	INTERRUPTOR LUZ AMARILLA
11	TR0402		3	TERMOMETRO DIGITALE	THERMOMETRE DIGITAL	DIGITAL THERMOMETER	DIGITAL THERMOMETER	TERMÓMETRO DIGITAL
12	TR0328		1	PULSANTE ARRESTO GENERALE	BOUTON D'ARRET GEN.	MAIN STOP PUSH BUTTON	NOT STOP TASTE	INTER. DETENCION GRAL.
13	TR0416		1	TRASFORMATORE 450VA	TRANSFORMATEUR	TRANSFORMER	TRANSFORMATOR	TRASFORMADOR
14	TR0217		1	INTERRUTTORE 2P 6A	INTERRUPTEUR	MAIN SWITCH	SCHALTER	INTERRUPTOR
15	TR0221		1	INTERRUTTORE 1P 20A	INTERRUPTEUR	MAIN SWITCH	SCHALTER	INTERRUPTOR
16	TR0213		1	INTERRUTTORE 3P 32A	INTERRUPTEUR	MAIN SWITCH	SCHALTER	INTERRUPTOR
17	TR0212		1	INTERRUTTORE 3P 20A	INTERRUPTEUR	MAIN SWITCH	SCHALTER	INTERRUPTOR
18	TR0218		1	INTERRUTTORE 3P 63A	INTERRUPTEUR	MAIN SWITCH	SCHALTER	INTERRUPTOR
19	TR1099		1	SUPP. COMP. ELETTRICI	SUPP. COMP. ELECTRIQUES	ELECTRIC COMP. SUPPORT	KOMPONENTE SUPPORT	SOPORTE COMP. ELECTRICOS
20	TR0494		1	CASSETTA ELETTRICA	BOITE ELECTRIQUE	CABINET	SCHALTKASTEN	CAJA ELÉCTRICA
21	TR0281		1	PANNELLO COMANDI	TABLEAU COMMANDE	CONTROL PANEL	SCHALTAFEL	PANEL DE COMANDO
22	TR0310		3	SELETTORE 0 - 1	SELECTEUR 0 - 1	SELECTOR 0 - 1	WAHLSCHALTER	SELECCIONADOR
23	TR0311		1	SELETTORE 0 - 1 - 2	SELECTEUR 0 - 1 - 2	SELECTOR 0 - 1 - 2	WAHLSCHALTER	SELECCIONADOR
24	TR0257		1	MORSETTO TERRA 35 mm ²	BORNE	TERMINAL	KLEMMLEISTE	GRAMPA TIERRA
25	TR0256		3	MORSETTO 70 mm ²	BORNE	TERMINAL	KLEMMLEISTE	GRAMPA
26	TR0319		9	MORSETTO 10 mm ²	BORNE	TERMINAL	KLEMMLEISTE	GRAMPA
27	TR0248		71	MORSETTO 4 mm ²	BORNE	TERMINAL	KLEMMLEISTE	GRAMPA
28	TR0334		1	MORSETTO CHIUSURA 10 mm ²	BORNE	TERMINAL	KLEMMLEISTE	GRAMPA DE LA CERRADURA
29	TR0300		2	RELÈ 24 V	RELAIS	RELAY	RELAIS	RELÈ
30	TR0390		1	TERMICA 0,63-1A	TERMIQUE	OVERLOAD RELAY	THERMOAUSLOSER	TERMICA
31	TR0393		1	TERMICA 2,5-4A	TERMIQUE	OVERLOAD RELAY	THERMOAUSLOSER	TERMICA
32	TR0400		1	TERMICA 4-6A	TERMIQUE	OVERLOAD RELAY	THERMOAUSLOSER	TERMICA
33	955068		1	MORSETTO NYLON 4 mm ²	BORNE	TERMINAL	KLEMMLEISTE	GRAMPA NAYLON
34	TR0498		1	COPERCHIO CASSETTA ELETTR.	COUVERCLE BOITE ELECTR.	CABINET COVER	SCHALTKASTEN DECKEL	TAPA CAJA ELÉCTRICA

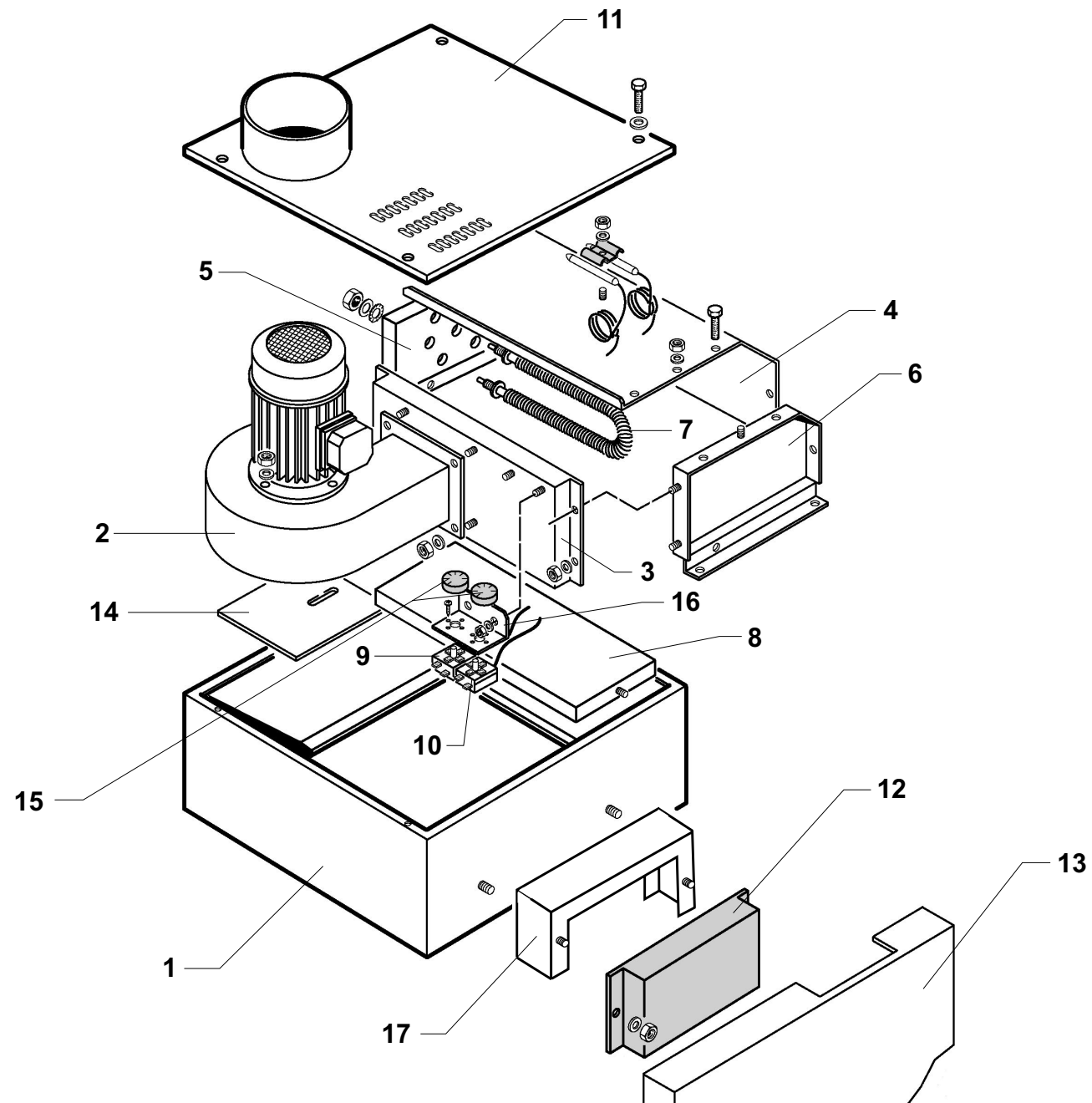

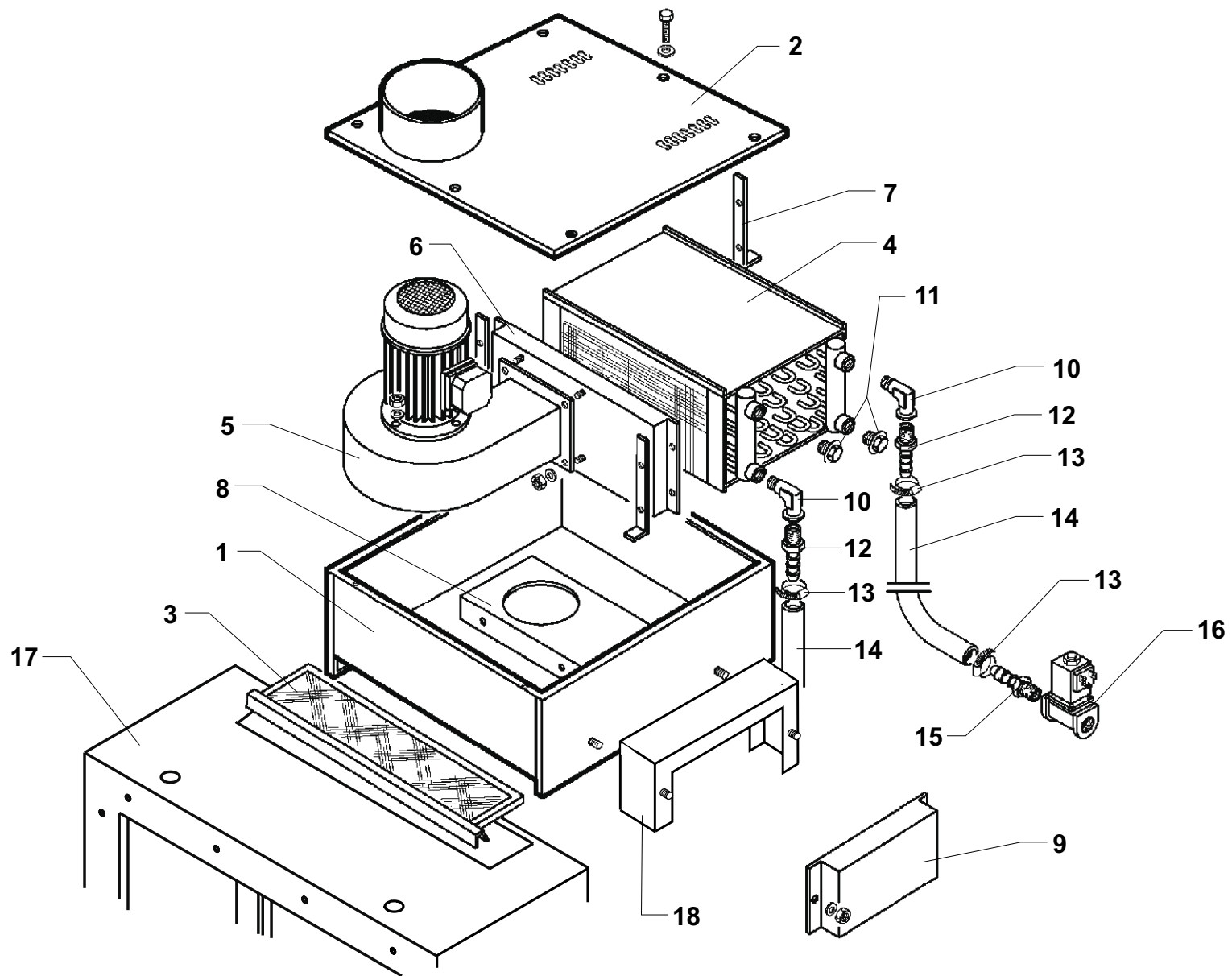

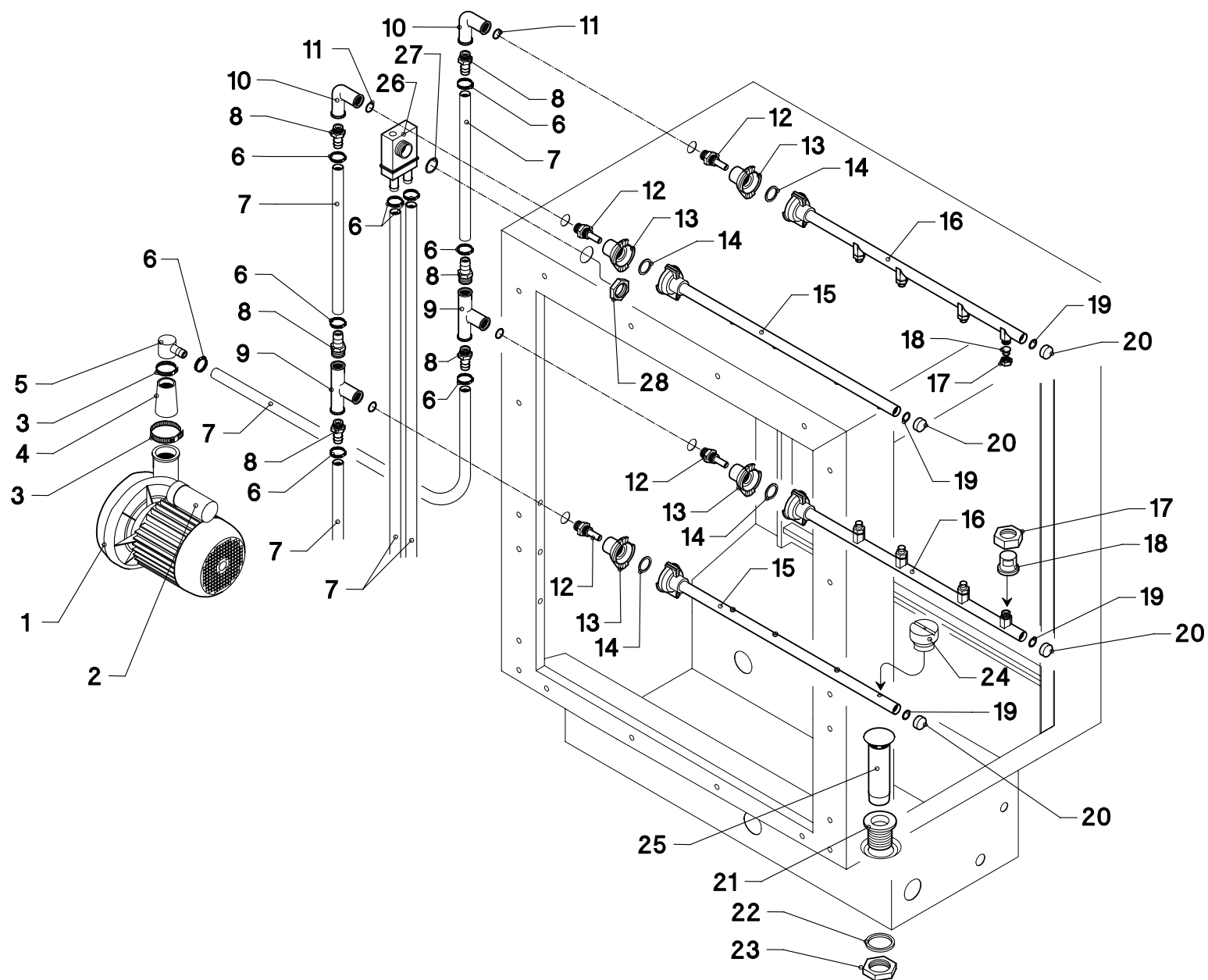

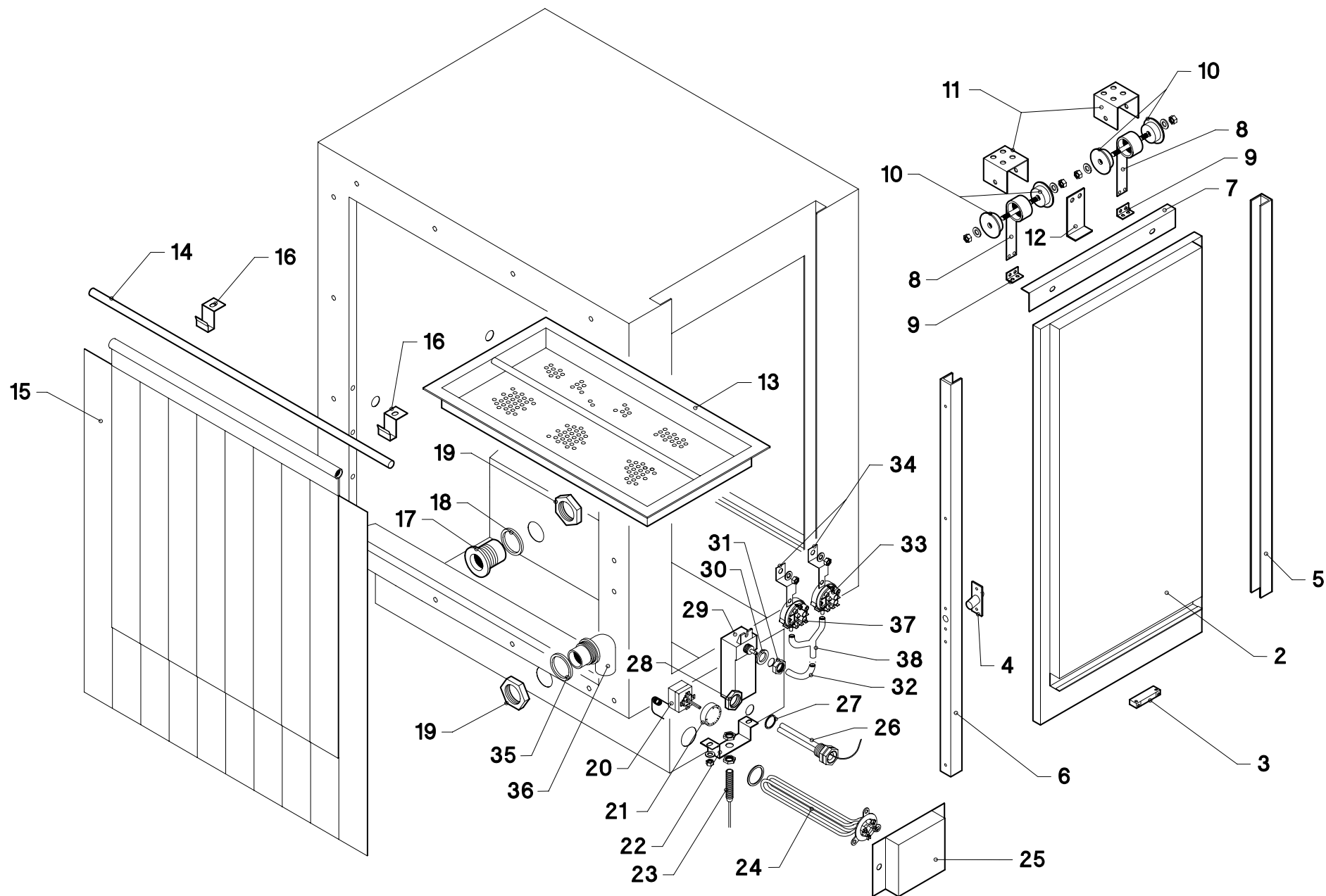

LAVASTOVIGLIE A NASTRO – DOPPIO RISCIAQUO

NS2500 – NS3500
NS5000 – NS6000

ED. 2000

TAV. 19

Pos.	COD.	COD.	Q.tà	DESCRIZIONE	DENOMINATION	DESCRIPTION	BEZEICHNUNG	DESCRIPCIÓN
1	TR3253		1	CAPOT	CAPOTE	HOOD	GEHÄUSE	CAPOT
2	TR1007		1	PORTA	PORTE	DOOR	TÜR	PUERTA
3	TR0220		1	CUSTODIA CON MAGNETE	PROTECTION MAGNETO	COVER MAGNET	MAGNETSCHUTZ	ESTUCHE CON IMAN
4	TR0620		1	BLOCCO SICUREZZA PORTA	BLOC DE SÉCURITÉ	SAFETY DOOR CATCH	BLOCK TÜR	BLOQUEO DE SEGUR. PUERTA
5	TR1083		1	GUIDA SCORRIMENTO DX	RAIL DX	GUIDE DX	FÜHRUNG DX	GUIA DESLIZAMENTO DX
6	TR1102		1	GUIDA SCORRIMENTO SX	RAIL SX	GUIDE SX	FÜHRUNG SX	GUIA DESLIZAMENTO SX
7	TR2006		1	PARASPRUZZI	GARDE-JETS	SPRAY-GUARD	SPRITZBLECH	SALPICADERO
8	TR1860		2	MOLLA PORTA	RESSORT	SPRING	FEDER	RESORTE PUERTA
9	TR0607		2	AGGANCIAMENTO MOLLA	CROCHET RESSORT	SPRING HOOKING	KUPPLUNGFEDER	ENGANCHE RESORTE
10	TR0999		4	SUPP. SCORRIMENTO MOLLA	SUPPORT POUR RESSORT	SPRING SUPPORT	FEDER TRÄGER	SOP. DESLIZAMIENTO RESORTE
11	TR2008		2	SQUADR. FISSAGGIO MOLLA	EQUERRE POUR RESSORT	SPRING SUPPORT	FEDER TRÄGER	ANGULAR FIJADORESORTE
12	TR2185		1	FERMO PORTA	ARRET DE PORTE	SPRING LOCK	FEST TÜR	TOPE PUERTA
13	TR2009		1	FILTRO	FILTRE	FILTRE	FILTER	FILTRO
14	TR2034		1	ALBERO PER TENDINA	ARBRE RIDEAU	CURTAIN ROD	HALTERUNG	EJE PARA CORTINILLA
15	TR0471		1	TENDINA	RIDEAU	CURTAIN	SPRITZSCHUTZ	CORTINILLA
16	TR2162		2	SQUADRETTA TENDINA	EQUERRE RIDEAU	BRACKET CURTAIN	WINKEL SPRITZSCHUTZ	ANGULAR CORTINILLA
17	905450		1	RACCORDO 1" ¼	RACCORD	PIPE FITTING	ABLAUFANSCHLUSS	EMPALME
18	904380		1	O-RING	O-RING	O-RING	O-RING	O-RING
19	902080		2	GHIERA 1" ¼	VIROLE	LOCK NUT	NUT MUTTER	ABRAZADERA
20	907100		1	TERMOSTATO	THERMOSTAT	THERMOSTAT	THERMOSTAT	TERMÓSTATO
21	903982		1	MANOPOLA	BOUTON	KNOB	KNOFF	EMPUÑADURA
22	TR1071		1	SQUADRETTA REED	EQUERRE REED	REED BRACKET	WINKEL REED	ANGULAR REED
23	TR0309		1	REED MAGNETICO	REED	REED	REED	REED MAGNÉTICO
24	905560		1	RESISTENZA 4500W	RESISTANCE	HEATING ELEMENT	HEIZKÖRPER	RESISTENCIA
25	TR1037		1	COPRIRESISTENZA	PROTECTION RESISTANCE	HEATING COVER	HEIZKÖRPER SCHUTZ	CUBRE RESISTENCIA
26	TR0298		1	PORTABULBO	SIÈGE DE BULBE	SEATING BULB	KUGELSITZ	PORTABULBO
27	903250		1	GUARNIZIONE	JOINT	GASKET	DICHTUNG	GUARNICIÓN
28	902061		1	GHIERA ½"	VIROLE	LOCK NUT	NUT MUTTER	ABRAZADERA
29	TR0268		1	TRAPPOLA ARIA	RESERVOIR AIR	AIR TRAP	LUFTFALLE	TRAMPA DEL AIRE
30	903260		1	GUARNIZIONE	JOINT	GASKET	DICHTUNG	GUARNICIÓN
31	902100		1	GHIERA 3/8"	VIROLE	LOCK NUT	NUT MUTTER	ABRAZADERA
32	907272		1	TUBO PRESSOSTATO	TUYAU PRESSOSTAT	PRESSURE SWITCH PIPE	SCHLAUCH	TUBO PRESÓSTATO
33	905272		1	PRESSOSTATO	PRESSOSTAT	PRESSURE SWITCH	DRUCHWAECHTER	PRESÓSTATO
34	906399		1	SQUADRETTA PRESSOSTATO	EQUERRE PRESSOSTAT	PRESSURE SWITCH BRACKET	WINKEL DRUCHWAECHTER	ANGULAR PRESÓSTATO

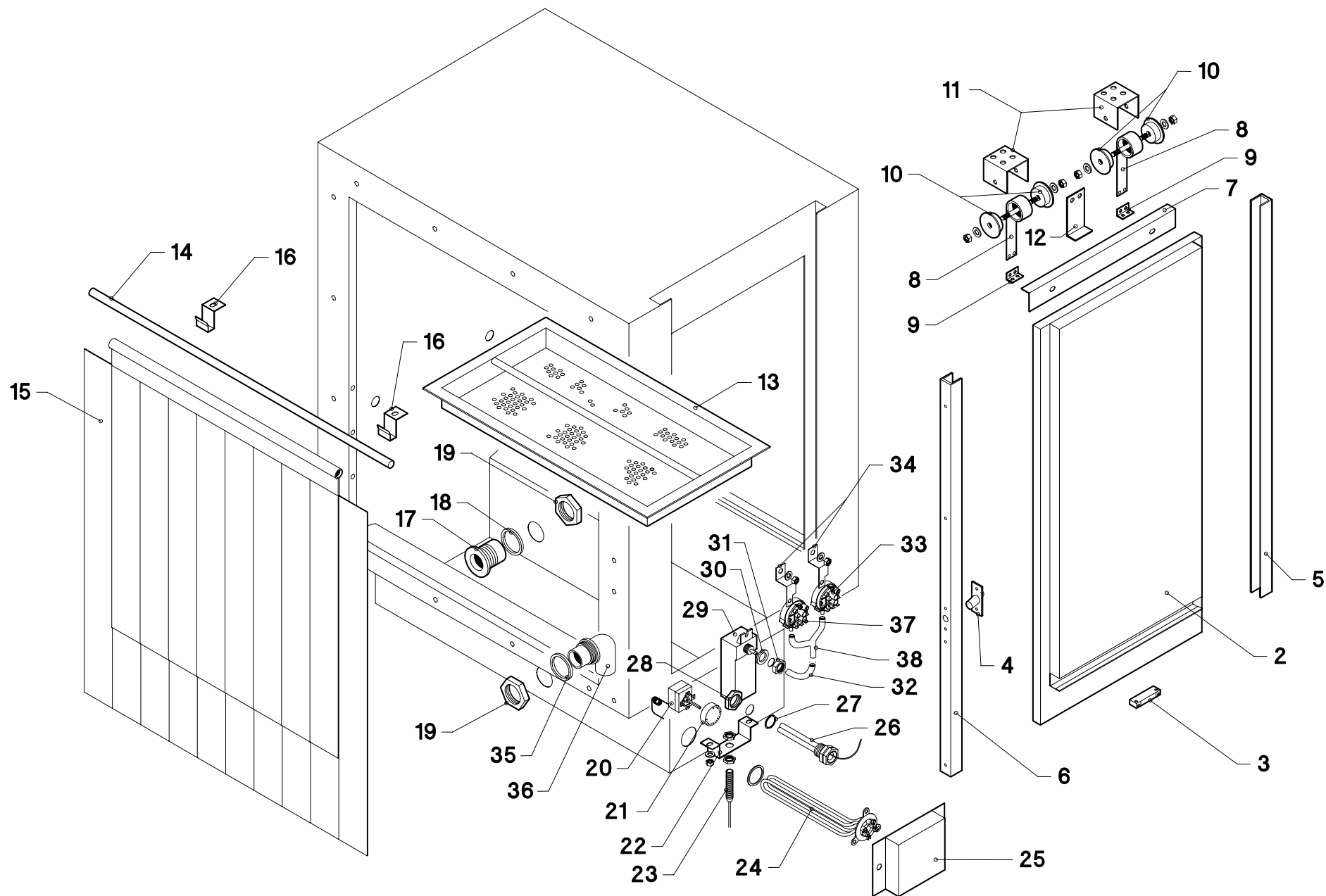

LAVASTOVIGLIE A NASTRO – DOPPIO RISCIACQUONS2500 – NS3500
NS5000 – NS6000

ED. 2000

TAV. 19

<i>Pos.</i>	<i>COD.</i>	<i>COD.</i>	<i>Q.tà</i>	<i>DESCRIZIONE</i>	<i>DENOMINATION</i>	<i>DESCRIPTION</i>	<i>BEZEICHNUNG</i>	<i>DESCRIPCIÓN</i>
35	903325		1	GUARNIZIONE	JOINT	GASKET	DICHTUNG	GUARNICIÓN
36	905410		1	RACCORDO GOMITO	RACCORD	PIPE FITTING	ANSCHLUSSE	EMPALME A CODO
37	905270		1	PRESSOSTATO	PRESSOSTAT	PRESSURE SWITCH	DRUCHWAECHTER	PRESÓSTATO
38	905423		1	RACCORDO A "Y"	RACCORD	PIPE FITTING	ABLAUFANSCHLUSS	EMPALME

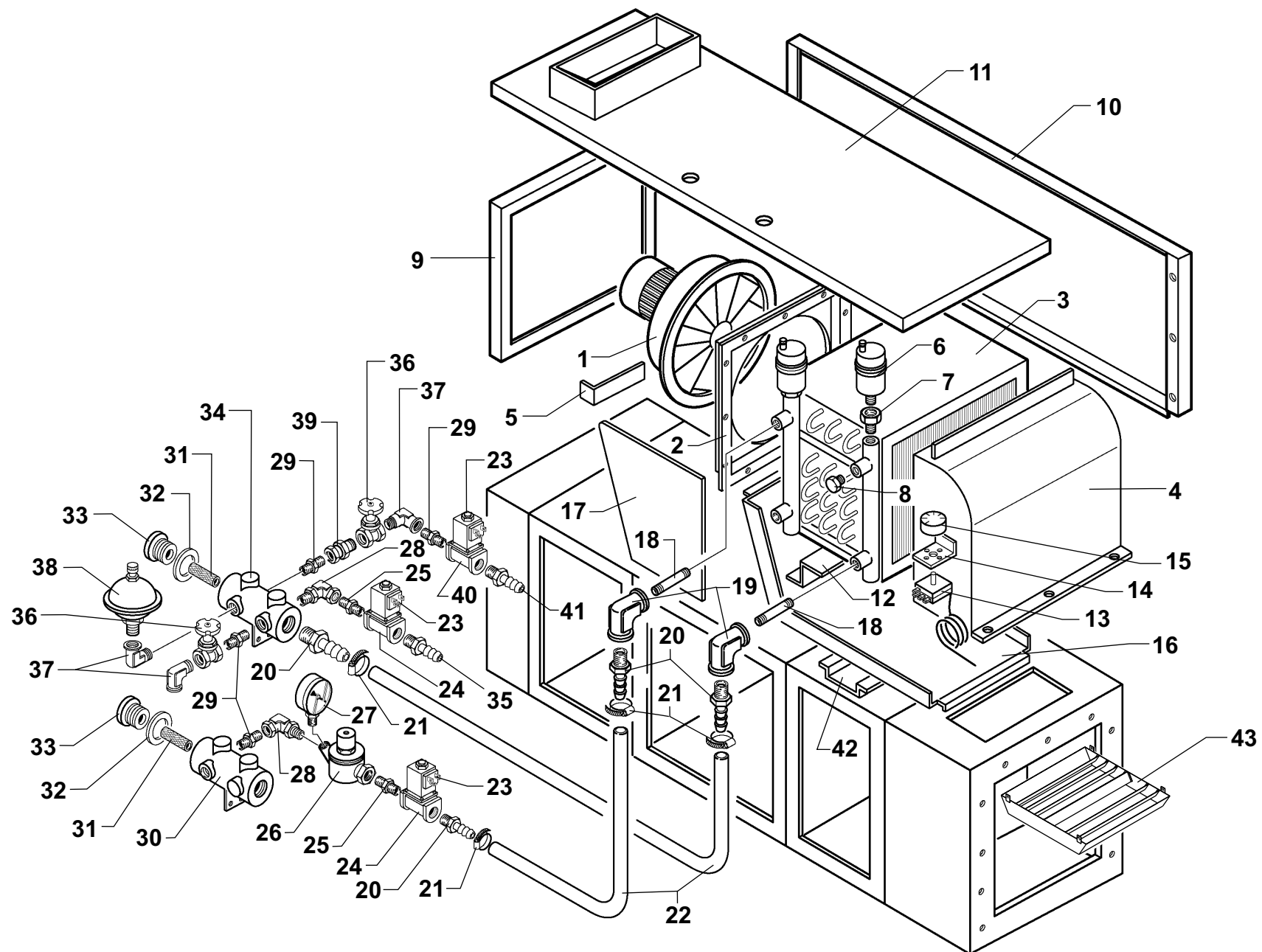

LAVASTOVIGLIE A NASTRO – RECUPERATORE DI CALORE

ED. 2000

TAV. 20

Pos.	COD.	COD.	Q.tà	DESCRIZIONE	DENOMINATION	DESCRIPTION	BEZEICHNUNG	DESCRIPCIÓN
1	TR0511		1	VENTILATORE 0,75 Hp	VENTILATEUR	FAN MOTOR	VENTILATOR	VENTILADOR
2	TR0488		1	SUPPORTO VENTILATORE	SUPPORT VENTILATEUR	FAN MOTOR SUPPORT	VENTILATOR TRÄGER	SOPORTE VENTILADOR
3	TR2175		1	BATTERIA R.C.	BATTERIE	BATTERY	BATTERIE	BATERÍA
4	TR 2176		1	CONVOGLIATORE	CONVOYER	CHANNEL	ABLEITBLECH	TRANSPORTADOR
5	TR 2179		2	SQUADRETTA PER PARATIA	EQUERRE PAROI	BULKHEAD BRACKET	LUFTLEITBLECH WINKEL	ANGULAR PARA TAPIQUE
6	TR 2371		2	VALVOLA DI SFIATO 3/8"	VANNE	VALVE	LUFTERVENTIL	VALVULA DESCOMPRESIÓN
7	TR 2451		2	PROLUNGA 3/8"-1/4"	PROLUNGEMENT	EXTENSION CORD	LEITUNGSTRECKER	PROLONGACIÓN
8	906415		2	TAPPO 3/4"	BOUCHON	PLUG	PROPFEN	TAPÓN
9	TR2123		2	SPALLA CASSONE DX-SX	SUPPORT CAISSON	HOUSING SUPPORT	VERKLEIDUNG HALTER.	APOYO CAJÓN IZQUIER.
10	TR2122		1	SPALLA CASSONE ANT.	SUPPORT CAISSON	HOUSING SUPPORT	VERKLEIDUNG HALTER.	APOYO CAJÓN ANTERIOR
10	TR2124		1	SPALLA CASSONE POST.	SUPPORT CAISSON	HOUSING SUPPORT	VERKLEIDUNG HALTER.	APOYO CAJÓN POSTERIOR
11	TR2125		1	COPERCHIO	COUVERCLE	COVER	DECKEL	TAPA
12	TR2180		2	SQUADRETTA SUPP. BATTERIA	EQUERRE BATTERIE	BATTERY BRACKET	BATTERIE TRÄGER	ANGULAR SOPORTE BATERÍA
13	907100		1	TERMOSTATO	THERMOSTAT	THERMOSTAT	THERMOSTAT	TERMÓSTATO
14	TR2144		1	SQUADRETTA TERMOSTATO	EQUERRE THERMOSTAT	THERMOSTAT BRACKET	THERMOSTAT WINKEL	ANGULAR TERMÓSTATO
15	903982		1	MANOPOLA	BOUTON	KNOB	KNOPF	EMPUÑADURA
16	TR2128		1	SCIVOLO	GLISSIERE	TANK FILLER	HINTERESLEITBLECH	DESLIZADOR
17	TR2178		1	PARATIA ANTERIORE	PAROI	BULKHEAD	LUFTLEITBLECH	TABIQUE ANTERIOR
17	TR2184		1	PARATIA POSTERIORE	PAROI	BULKHEAD	LUFTLEITBLECH	TABIQUE POSTERIOR
18	TR2308		2	TUBO ZINCATO 3/4"-3/4"	TUYAU	PIPE	RORH	TUBO CINCO
19	TR2439		2	RACCORDO GOMITO F/F	RACCORD	PIPE FITTING	ANSCHLUSSE	EMPALME CODO
20	TR2216		4	RACCORDO PORTAGOMMA 3/4"	RACCORD	PIPE FITTING	ANSCHLUSSE	EMPALME GOME PARA PUERTA
21	902460		4	FASCETTA 26÷38	COLLIER	CLAMP	SHELLE	ABRAZADERA
22	TR0469		2	TUBO GOMMA 19x31	TUYAU EN CAOUTCHOUC	RUBBER PIPE	GUMMISCHLAUCH	TUBO GOMA
23	TR0020		3	BOBINA 24V	BOBINE	COIL	SPULE	BOBINA
24	TR0090		2	ELETTROVALVOLA 3/4"	ELECTROVANNE	ELECTRIC VALVE	ELEKTROVENTIL	VALVULA ELECTRICA
25	TR2352		2	NIPPLO RIDOTTO 1/2"-3/4"	NIPPLES	NIPPLE	NIPPLE	NIPLE REDUCCIÓN
26	TR0371		1	RIDUTTORE DI PRESSIONE	REDUCTEUR	PRESSURE REDUCER	DRUCKMINDERER	REDUCTOR DE PRECIÓN
27	TR0399		1	MANOMETRO PER RIDUTTORE	MANOMETRE REDUCTEUR	PRESSURE GANGE	DRUCKMESSER	MANÓMETRO PARA REDUCTOR
28	TR2333		2	BOCCHETTONE CURVO 1/2"	GOULOTTE	PIPE UNION	STUTZEN	RAMPA DE DESAGÜE CURVO
29	TR2322		4	NIPPLO 1/2"	NIPPLES	NIPPLE	NIPPLE	NIPLE
30	TR0126		1	FILTRO 2 VIE	FILTRE	FILTER	FILTER	FILTRO 2 DIRECCIONES
31	TR0123		2	FILTRO A CARTUCCIA	FILTRE	FILTER	FILTER	FILTRO CON CARTUCHO
32	903406		2	GUARNIZIONE	JOINT	GASKET	DICHTUNG	GUARNICIÓN

