

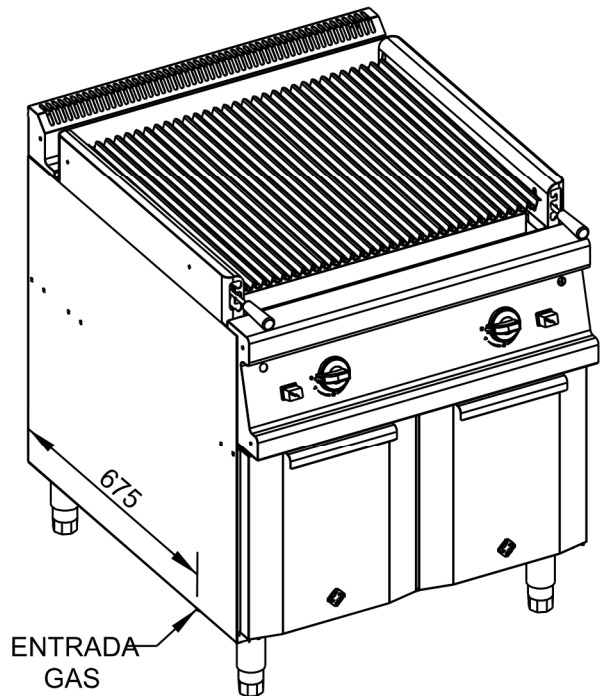

926/MA/11/05

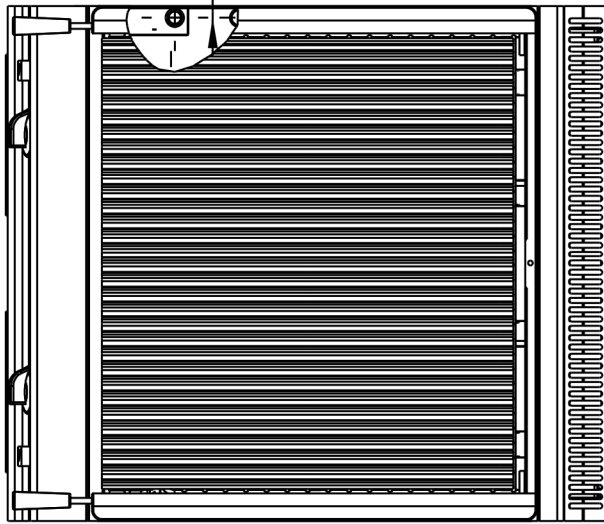

4785/ER/11/05

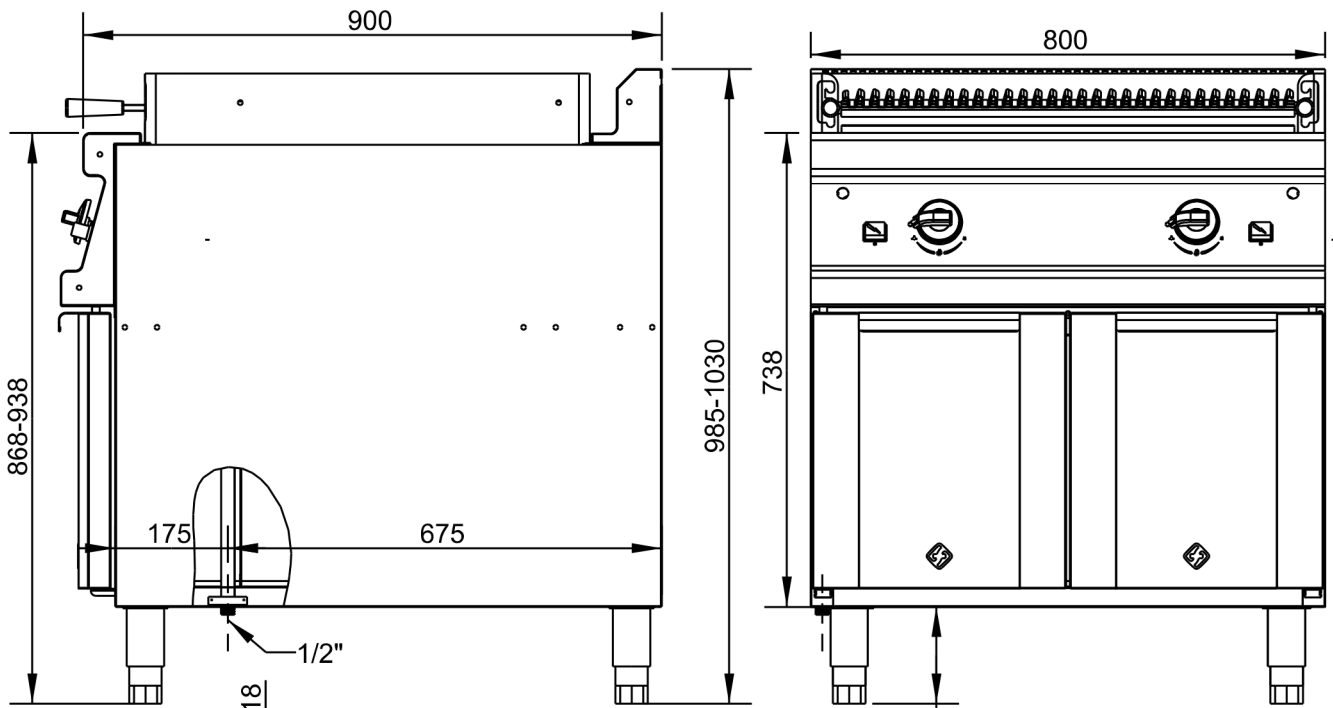

FUNDADA EN 1978  
**MASBAGA**  
SEMPRE COCINANDO

**EURAST**

**macfrin**

TOLERANCIAS GENERALES: ±0.1 mm



**COOKING SYSTEMS,SL**

FAMILIA: COCINAS 2008

MODELO: 4702 - HBG - PG89

DATA:  
07/01/09

DENOMINACION:  
BBQ 800X900

ESCALA:  
1/10

MATERIAL:  
INOX

CODIGO:  
4702



926/MA/11/05



4785/ER/11/05

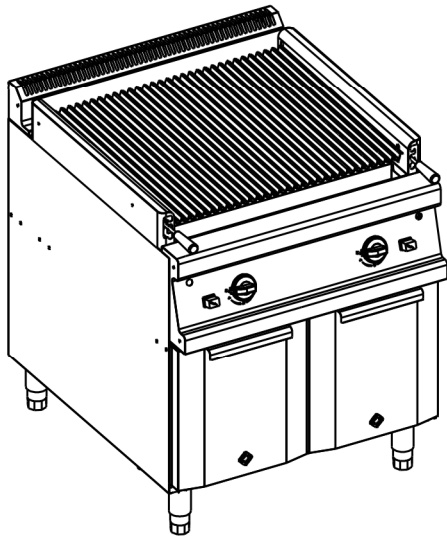

QT	COD	DESCRIPCION
2	3747	PIEZO ELECTRICO SIT
1	330213	TRASERO 800
1	340508	LATERAL DERECHO 900
1	340509	LATERAL DERECHO 900
1	340563	BASE 800 X 900
2	350104	OMEGA COCINA 800
2	350503	BISAGRA
1	350565	FRONTAL INFERIOR 800
1	350599	TAPA TUBOS ENTRADA GAS
2	362133	PROTECTOR PIEZO ELECTRICO
1	470449	CANAL BBQ 800
1	4704491	CANAL EXTRAÍBLE BBQ 800
1	330685PC	BATERIA COMPLETA COCINA 2F. 800
1	340122C	CONJUNTO PETO 800
2	340173PM	CONJUNTO MANDO A GAS
1	350485PC	BATERIA COMPLETA ARMARIO
2	350503P	EJE SUPERIOR PUERTA
2	350505M	CONJUNTO PUERTA COCINA DCHA/IZQ.
1	470201M	CONJ FNC BBQ MONTADA 800X900
1	470201P	PARRILLA CARNE BBQ 800X900
1	470216M	DEFLECTOR MONTADO 800X900
1	470439C	CONJUNTO FRONTAL BBQ 800
2	C5811429M	GRIFO COCINA 21-S COMPLETO
4	C6260511	PATA INOX 130-200 (S_F)
4	C9500009	PIEDRA VOL CÁNICA (BOLSA 3KG.)

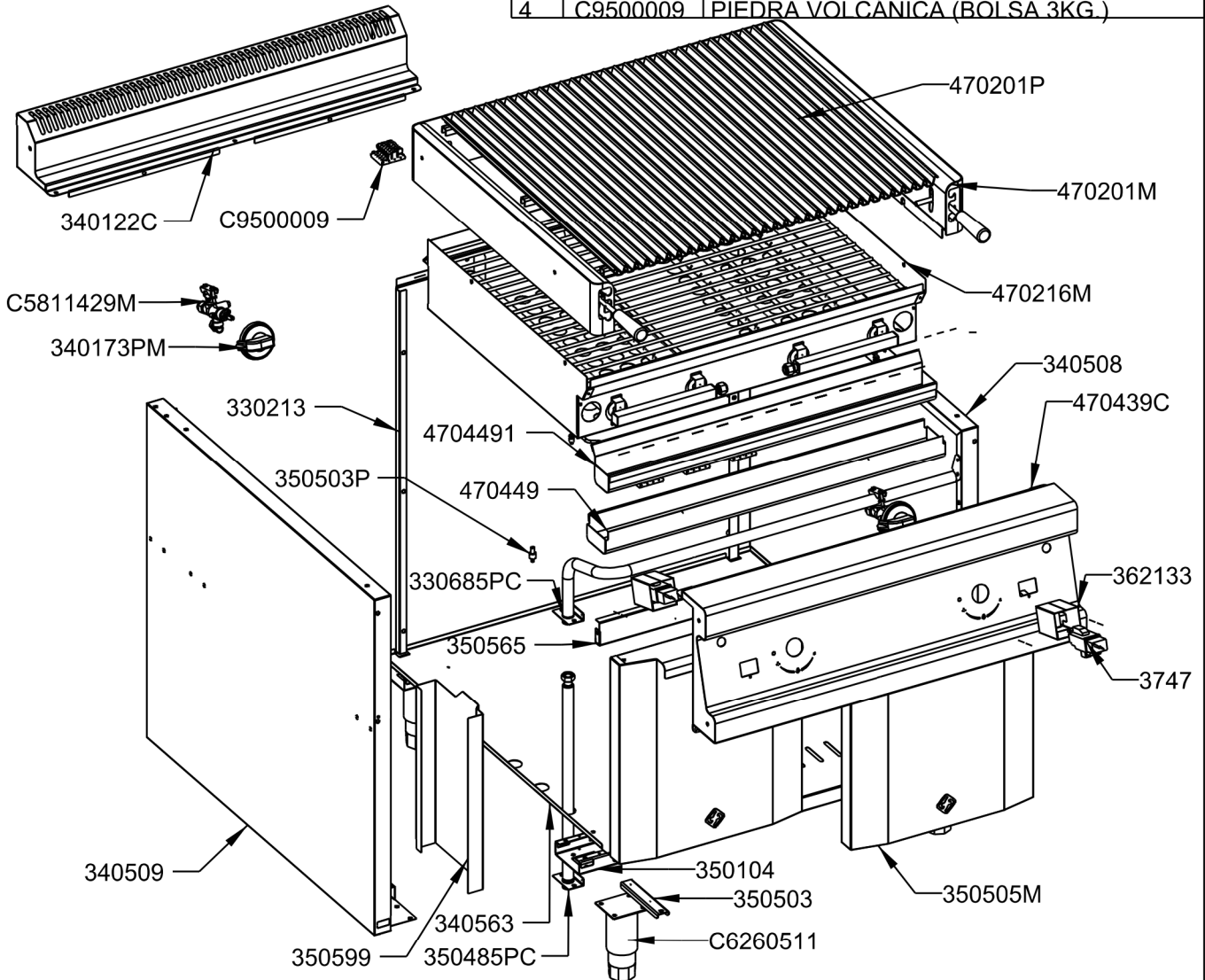

FUNDADA EN 1978  
**MASBAGA**  
SEMPRE COCINANDO

**EURAST**

**macfrin**

TOLERANCIAS GENERALES: ±0.1 mm



**COOKING SYSTEMS, SL**

DENOMINACION:  
BBQ 800X900

FAMILIA: COCINAS 2008

MODELO: 4702 - HBG - PG89

DATA:  
07/01/09

ESCALA:  
1/20

MATERIAL:  
INOX

CODIGO:  
4702



926/MA/11/05



4785/ER/11/05



QT	COD	DESCRIPCION
4	1091	PASADOR 2X16
4	1095	TORNILLO M-5X10 TLR INOX
2	2175	CABLE PIEZO L=760
4	3315	VARILLA MEC.ELEVACION
4	3326	CASQUILLO PARA SOLDAR
2	3747	PIEZO ELECTRICO SIT
4	3781	TUERCA M16X1.5 D.10
4	3782	BICONO D.10 LATON
2	3810	RACORD LATON 90° M-16X1.5
1	4702	BBQ 800X900
2	6036	MANGO BAQUELITA CONICO
8	300187	REGISTRO TRASERO QUEMADOR
2	300388	CORRELLAMAS
2	300399	TAPA 20X20 C/AGUJERO D.12
2	301399	TAPA 20X20
2	330189	MANGUITO M16X1.5 TUBO D.10
1	330194	PLETINA LATERAL BATERÍA
1	330213	TRASERO 800
2	330294	PLETINA BASE BATERÍA
1	340122	PETO SOBRE 800X750/900
1	340178	TAPETA DERECHA PETO 750/900
1	340179	TAPETA IZQ. PETO 750/900
1	340508	LATERAL DERECHO 900
1	340509	LATERAL DERECHO 900
1	340563	BASE 800 X 900
2	350104	OMEGA COCINA 800
1	350178	TAPETA LATERAL DERECHA FRONTAL
1	350179	TAPETA LATERAL IZQUIEDA FRONTAL
2	350503	BISAGRA
2	350505	PUERTA ARMARIO COCINA
2	350518	CONTRAPUERTA ARMARIO COCINA
1	350565	FRONTAL INFERIOR 800
1	350599	TAPA TUBOS ENTRADA GAS
2	362133	PROTECTOR PIEZO ELECTRICO
1	470178	LATERAL DCHO.SOBRE BBQ.900
1	470179	LATERAL IZQ. SOBRE BBQ.900
1	470201	ENCIMERA 800X900
1	470216	DEFLECTOR BBQ 800X900
1	470439	FRONTAL MANDOS BBQ 800X750/900
3	470448	GUIA REFUERZO PARRILLA CARNE 800
1	470449	CANAL BBQ.800
1	4704491	CANAL EXTRAÍBLE BBQ.800
1	330685P	BATERIA 2F 800
1	330685PC	BATERIA COMPLETA COCINA 2F. 800

FUNDADA EN 1978  
**MAS BAGA**  
SEMPRE COCINAS

**EURAST**

**macfrin**

TOLERANCIAS GENERALES: ±0.1 mm

  
**COOKING SYSTEMS, SL**

FAMILIA: COCINAS 2008

MODELO: 4702 - HBG - PG89

DATA:  
07/01/09

DENOMINACION:  
BBQ 800X900

ESCALA:  
1/10

MATERIAL:  
INOX

CODIGO:  
4702



926/MA/11/05



4785/ER/11/05



1	340122C	CONJUNTO PETO 800
2	340172P	ENVELLECEDOR MANDO GAS/ELECT.
2	340173P	MANDO COCINA GAS 2008
2	340173PM	CONJUNTO MANDO A GAS
1	350485P	BATERIA ARMARIO COCINA
1	350485PC	BATERIA COMPLETA ARMARIO
2	350503P	EJE SUPERIOR PUERTA
2	350505M	CONJUNTO PUERTA COCINA DCHA/IZQ.
4	361187P	QUEMADOR TUBULAR D.40 L.550
29	470148P	CANAL PARR.CARNE CENT.BBQ 900
1	470201C	CONJ.ENC.BBQ.SOLD.800X900
1	470201M	CONJ.ENC.BBQ.MONTADA 800X900
1	470201P	PARRILLA CARNE BBQ 800X900
1	470202P	PARRILLA LAVA BBQ 800X900
2	470210P	BIELA TRASERA BBQ. 900
1	470216M	DEFLECTOR MONTADO 800X900
2	470240P	BIELA FRONTAL BBQ. 900
1	470248P	CANAL PARR.CARNE LAT.BBQ 900
1	470439C	CONJUNTO FRONTAL BBQ 800
2	493086P	COLECTOR HGR
2	493086PC	COLECTOR 2 SALIDAS HGR
2	A1018996	RACORD BUJIA
2	A1018997	RACORD PILOTO
2	A1018998	RACORD TERMOPAR
2	A1018999	BICONO PILOTO
2	C5810129	PILOTO POLIDORO
2	C5810129M	PILOTO POLIDORO COMPLETO
2	C5810139	BUJIA
2	C5810159	INYECTOR PILOTO GN (27.2) 2 AGUJ.
2	C5810169	INYECTOR PILOTO GLP (22) 1 AGUJ.
2	C5811429	GRIFO VALVULA COCINA 21S D.1/2"
2	C5811429M	GRIFO COCINA 21-S COMPLETO
1	C5811459	RACORD 2P. 359GLCU-COAS 14X1/2"
2	C5811829	TERMOPAR LISO M9X1 L 600
4	C5812659	INY.D.120 GLP Q.L.550 / GN Q.L.300
4	C5812679	INYECTOR D.180 GN QUEMADOR L.550
2	C5815359	TUERCA+BICONO D.6 M10X1
4	C6260511	PATA INOX 130-200 (S_F)
4	C9500009	PIEDRA VOLCÁNICA (BOLSA 3KG.)
8	TESTA35	ANGULO TESTATINA 35
6	TESTA70	ANGULO TESTATINA 70

FUNDADA EN 1978  
**MASBAGA**  
SEMPRE COCINAS

**EURAST**

**macfrin**

TOLERANCIAS GENERALES: ±0.1 mm

  
**COOKING SYSTEMS,SL**

FAMILIA: COCINAS 2008

MODELO: 4702 - HBG - PG89

DATA:  
07/01/09

DENOMINACION:  
BBQ 800X900

ESCALA:  
1/10

MATERIAL:  
INOX

CODIGO:  
4702



926/MA/11/05



4785/ER/11/05



FUNDADA EN 1978  
**MASBAGA**  
REFRIGERACIONES

**EURAST**

**macfrin**

TOLERANCIAS GENERALES: ±0.1 mm

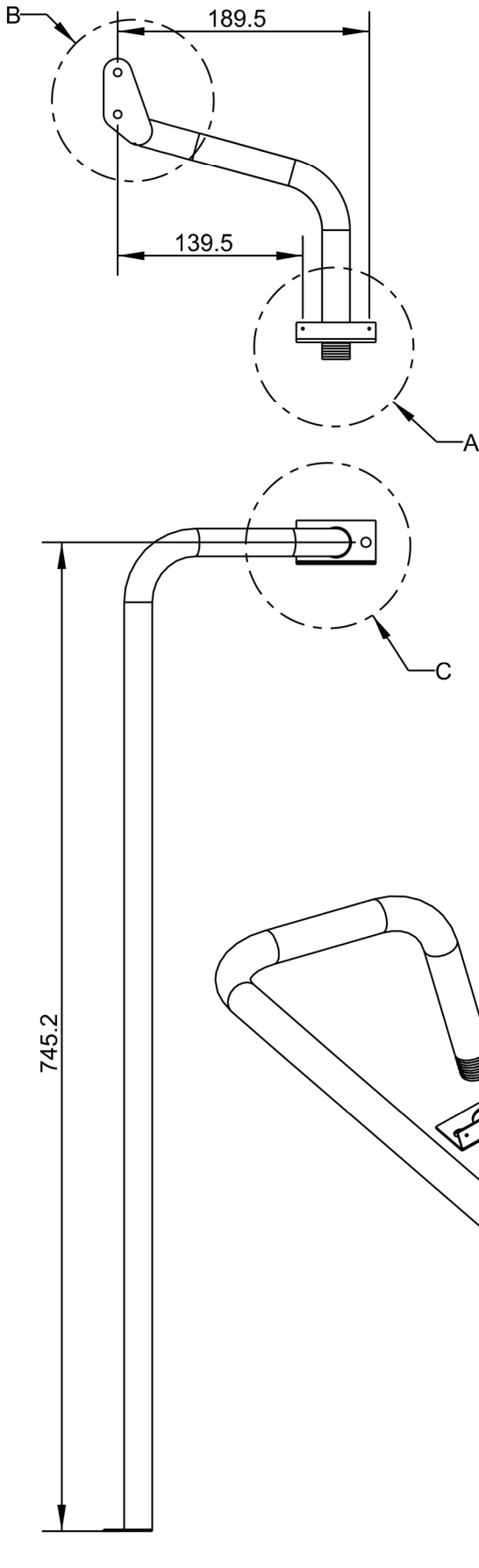

QT	COD	DESCRIPCION
1	330685P	BATERIA 2F 800
1	330294	PLETINA BASE BATERÍA
1	330194	PLETINA LATERAL BATERÍA

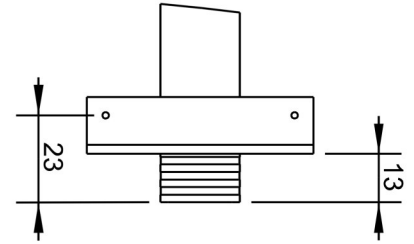

DETALLE A  
ESCALA 1/2

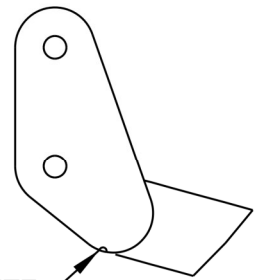

MUY IMPORTANTE  
ALINEAR MUESCA  
CON AGUJEROS Ø 10

DETALLE B  
ESCALA 1/2

CORDON POR ARRIBA  
A LOS 2 LADOS

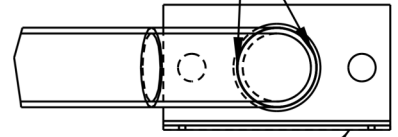

OJO: ALA PLETINA  
POR ESTE LADO

DETALLE C  
ESCALA 1/2

SOLDAR 330685P CON 330194 TOTALMENTE ESTANCO  
PUNTEAR A 2 LADOS SEGUN SE INDICA 330685P CON 330294

  
**macfrin**  
group  
**COOKING SYSTEMS, SL**

FAMILIA: COCINAS 2008

DATA:  
21/10/08

MODELO: 3306

DENOMINACION:  
BATERIA COMPLETA COCINA 2F. 800

ESCALA:  
1/4

MATERIAL:  
FE  
TRATAMIENTO:  
ZINCADO

PROGRAMA:  
3306-85-PC



926/MA/11/05



4785/ER/11/05



QT	COD	DESCRIPCION
1	340122	PETO SOBRE 800X750/900
1	340178	TAPETA DERECHA PETO 750/900
1	340179	TAPETA IZQ. PETO 750/900
2	TESTA35	ANGULO TESTATINA 35
2	TESTA70	ANGULO TESTATINA 70

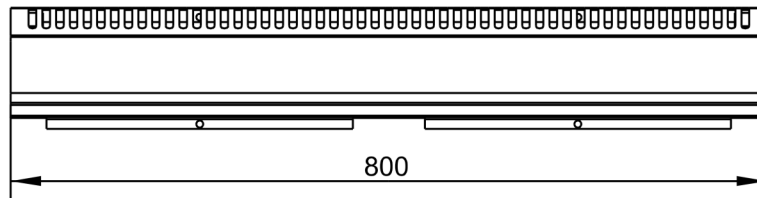
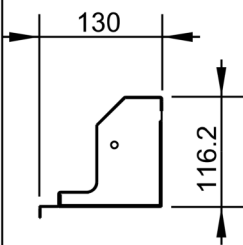
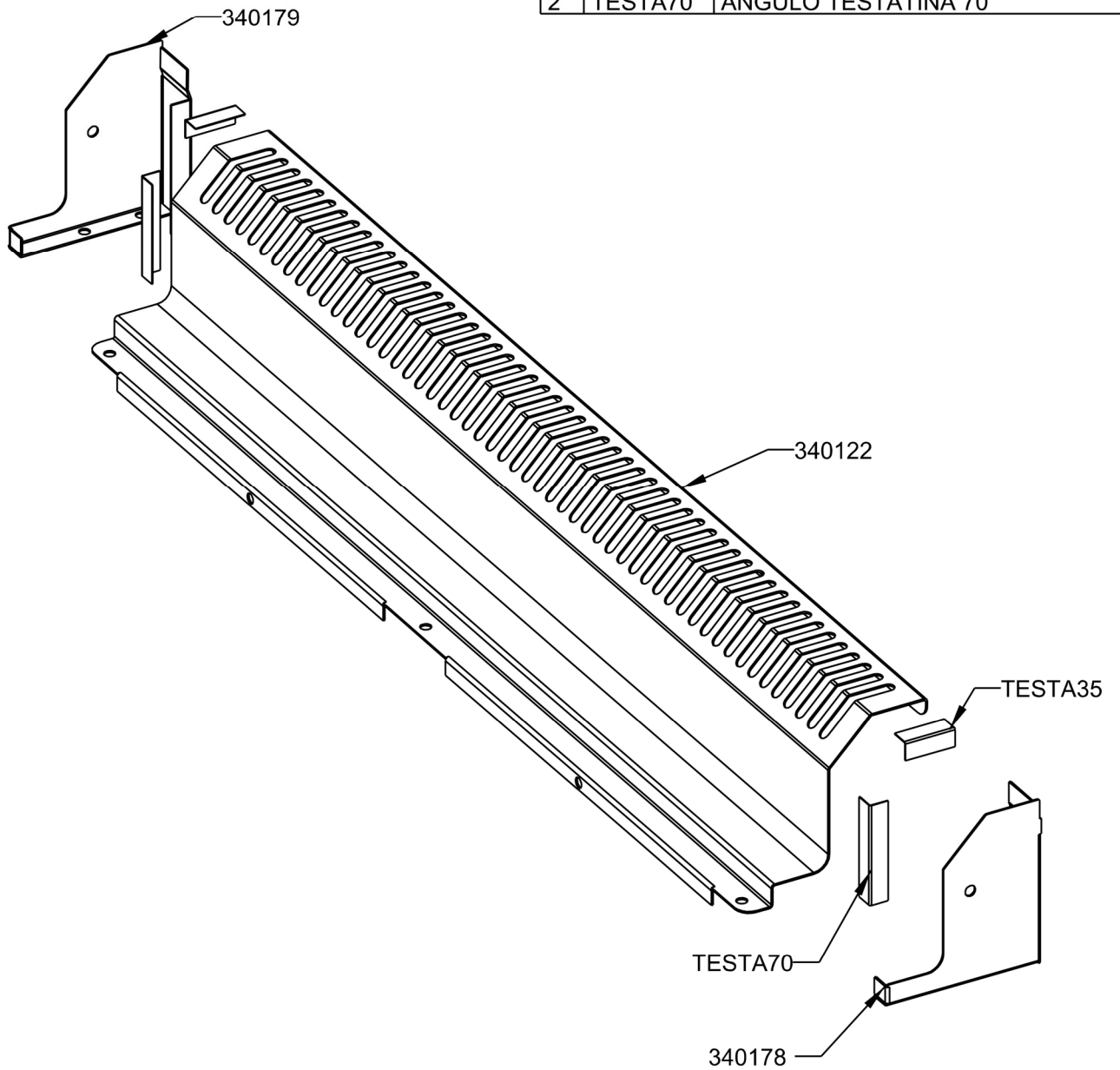

FUNDADA EN 1978  
**MAS BAGA**  
SEMPRE COCINANDO

**EURAST**

**macfrin**

TOLERANCIAS GENERALES: ±0.1 mm

**macfrin** group  
**COOKING SYSTEMS,SL**

FAMILIA: COCINAS 2008

MODELO: 3401

REF.	
O.F.	
QT.	
DEST.	SOLDAR

DATA:  
16/09/08

DENOMINACION:  
CONJUNTO PETO 800

ESCALA:  
1/4

MATERIAL:  
INOX

PROGRAMA:  
3401-22-C



926/MA/11/05



4785/ER/11/05

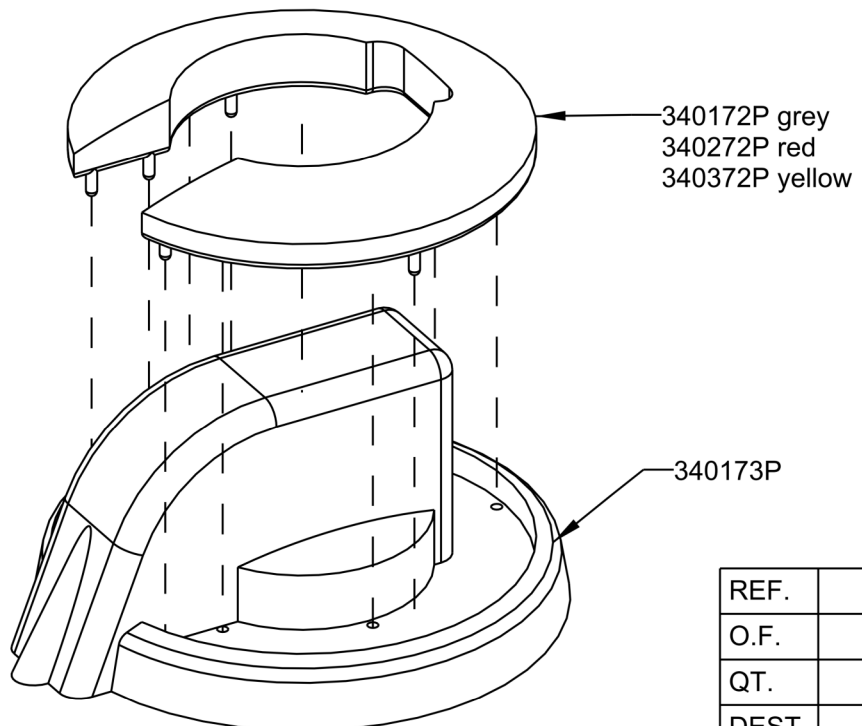
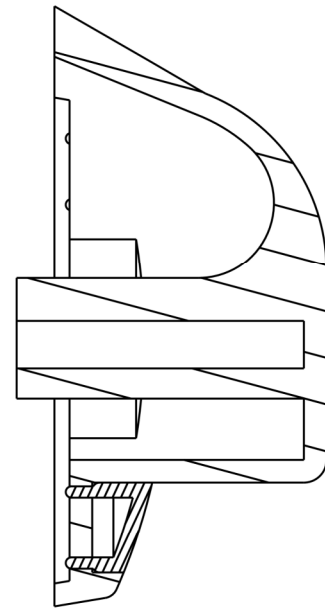
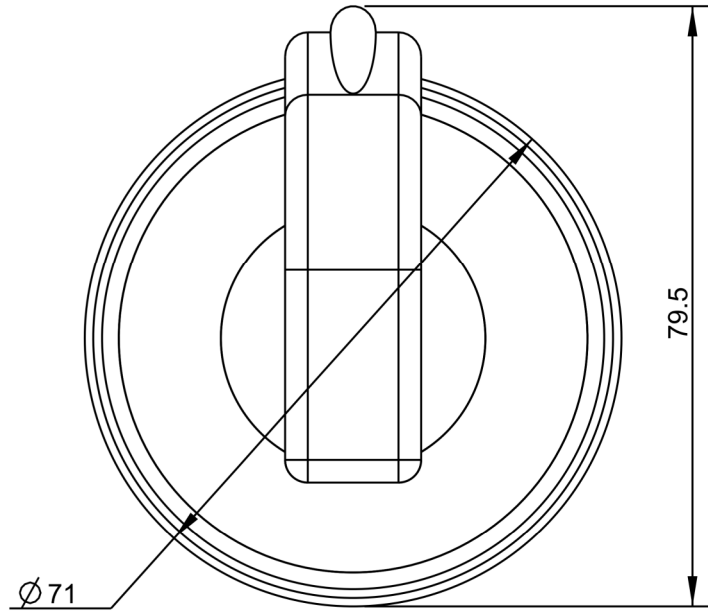
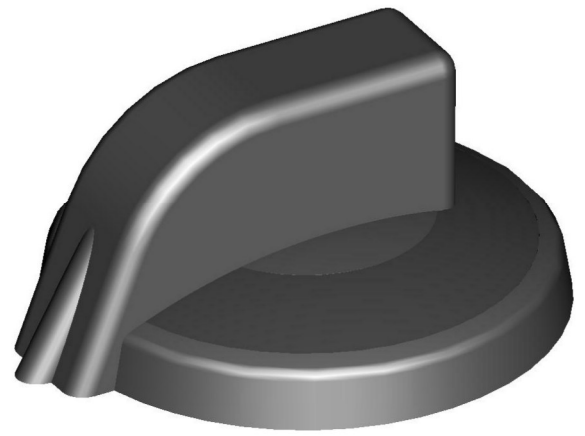
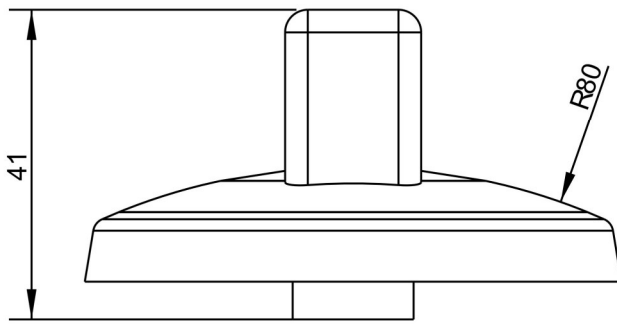

TOLERANCIAS GENERALES: ±0.1 mm

**macfrin**  
group  
COOKING SYSTEMS,SL

FAMILIA: COCINAS 2007

MODELO: 3401

REF.	
O.F.	
QT.	
DEST.	

DATA:  
10/12/07

DENOMINACION:  
CONJUNTO MANDO A GAS

ESCALA:  
1/1

MATERIAL:  
BAK + ABS

PROGRAMA:  
340173PM grey  
340273PM red  
340373PM yellow



926/MA/11/05



4785/ER/11/05



QT	COD	DESCRIPCION
1	330294	PLETINA BASE BATERÍA
1	350485P	BATERIA ARMARIO COCINA
1	C5811459	RACORD 2P. 359GLCU-COAS 14X1/2"

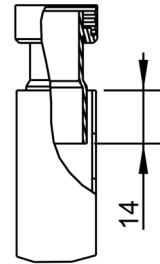
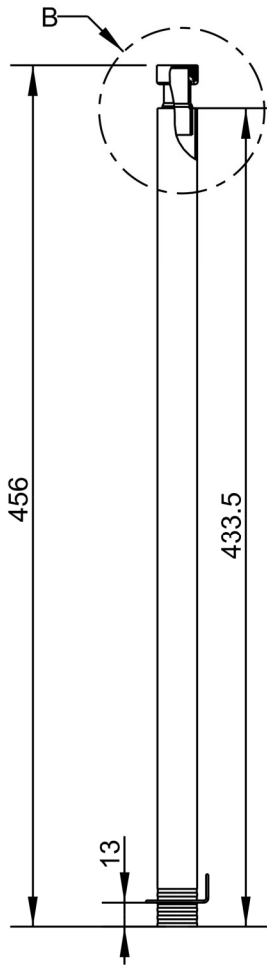

MUY IMPORTANTE  
SOLDADURA CON PLATA  
DETALLE B  
ESCALA 1/2

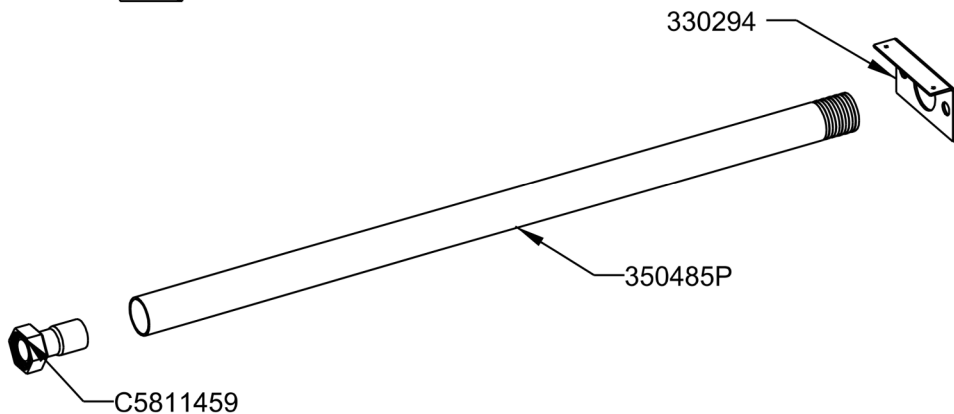

FUNDADA EN 1978  
**MASBAGA**  
BATERIAS COCINAS

**EURAST**

**macfrin**

TOLERANCIAS GENERALES: ±0.1 mm

**macfrin**  
group  
**COOKING SYSTEMS,SL**

FAMILIA: COCINAS 2008

DATA:  
14/11/08

MODELO: 3504

DENOMINACION:  
BATERIA COMPLETA ARMARIO

ESCALA:  
1/4

MATERIAL:  
FE  
TRATAMIENTO:  
ZINCADO

PROGRAMA:  
3504-85-PC



926/MA/11/05



4785/ER/11/05



QT.	CODIGO	DESCRIPCION
1	350505	PUERTA ARMARIO COCINA
1	350518	CONTRAPUERTA ARMARIO COCINA
1	350505M	CONJUNTO PUERTA COCINA DCHA/IZQ.

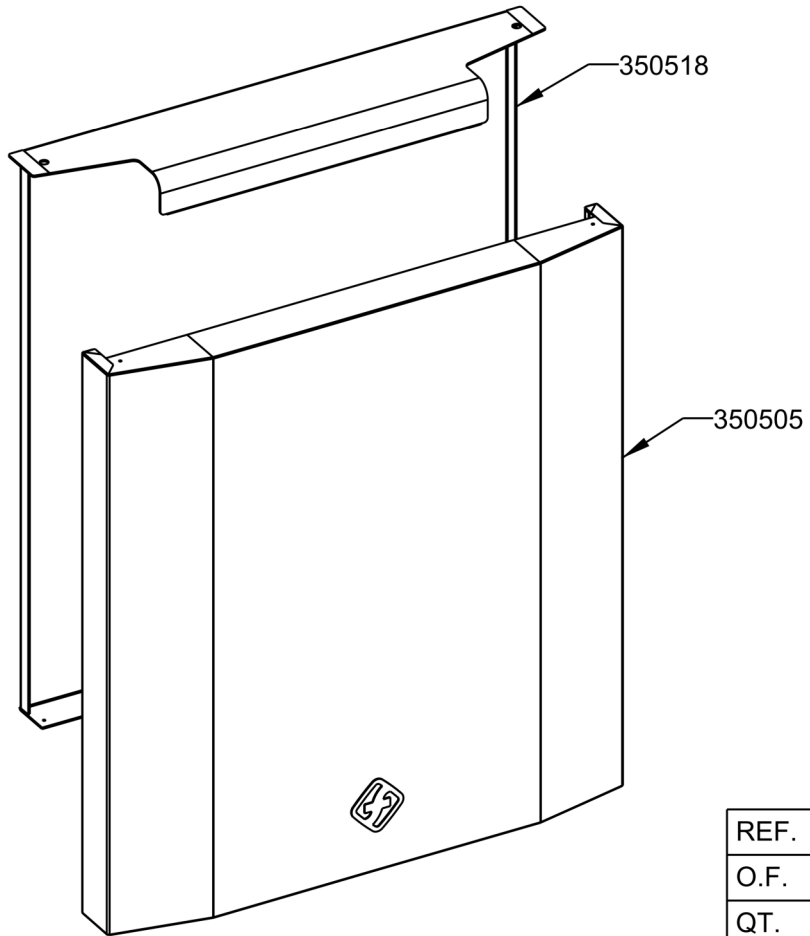
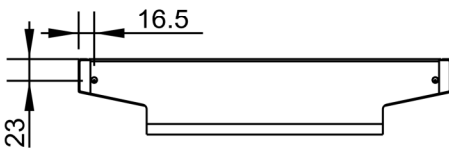
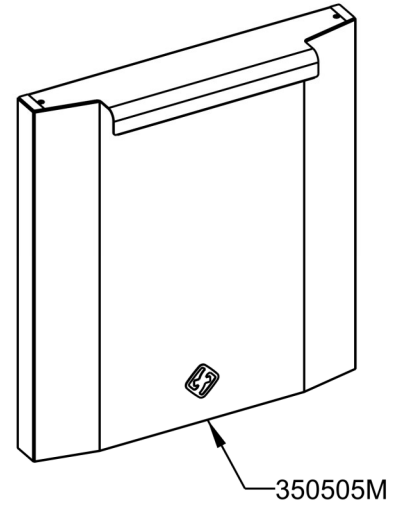
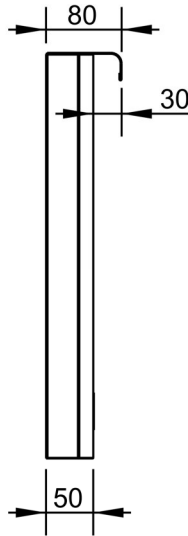
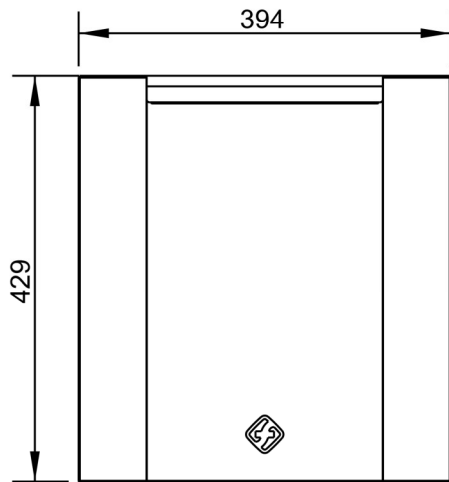

TOLERANCIAS GENERALES: ±0.1 mm



FAMILIA: COCINAS 2008

MODELO: 3505

REF.	
O.F.	
QT.	
DEST.	

DATA:  
26/05/08

DENOMINACION:  
CONJUNTO PUERTA COCINA DCHA/IZQ.

ESCALA:  
1/8

MATERIAL:  
INOX

PROGRAMA:  
3505-05-M



926/MA/11/05



4785/ER/11/05



TOLERANCIAS GENERALES: ±0.1 mm

QT	COD	DESCRIPCION
2	470240P	BIELA FRONTAL BBQ. 900
2	470210P	BIELA TRASERA BBQ. 900
1	470201C	CONJ.ENC.BBQ.SOLD.800X900
2	6036	MANGO BAQUELITA CONICO
4	1091	PASADOR 2X16
4	1095	TORNILLO M-5X10 TLR INOX
4	3315	VARILLA MEC.ELEVACION

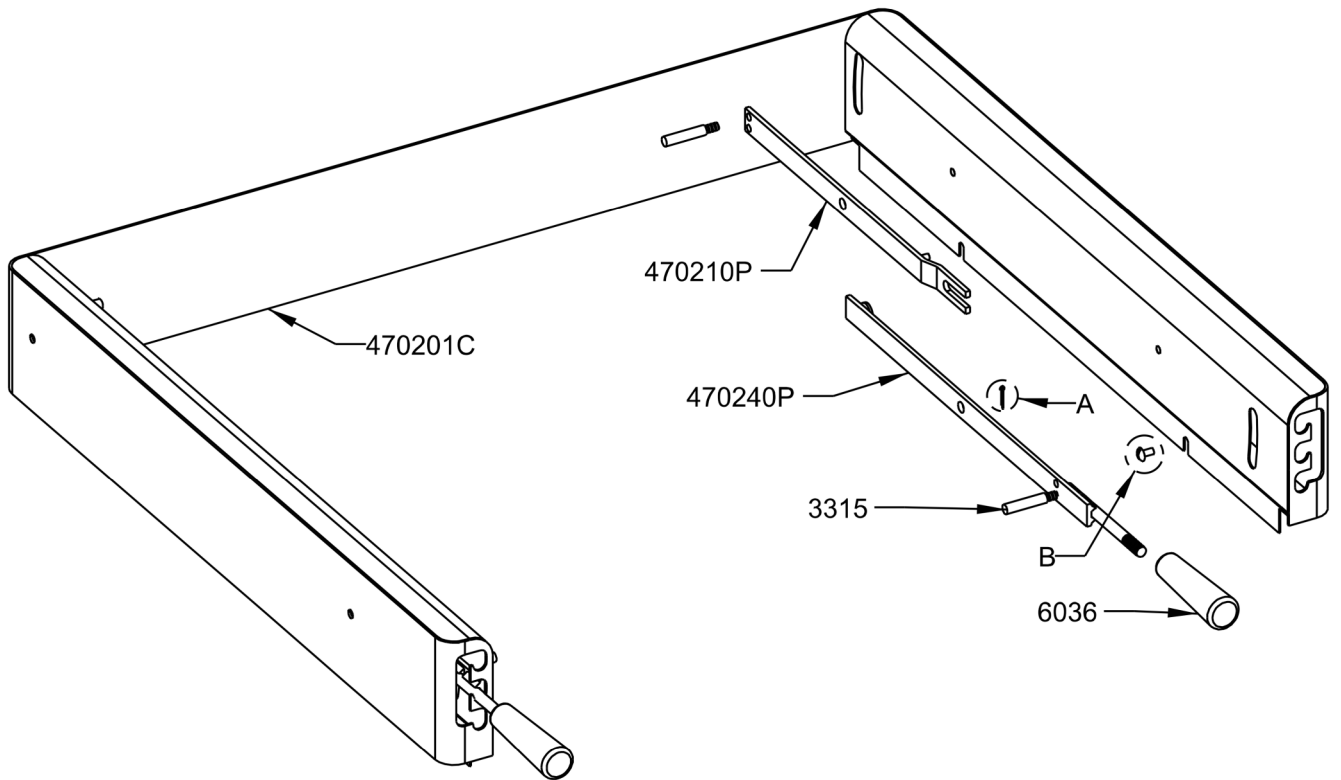
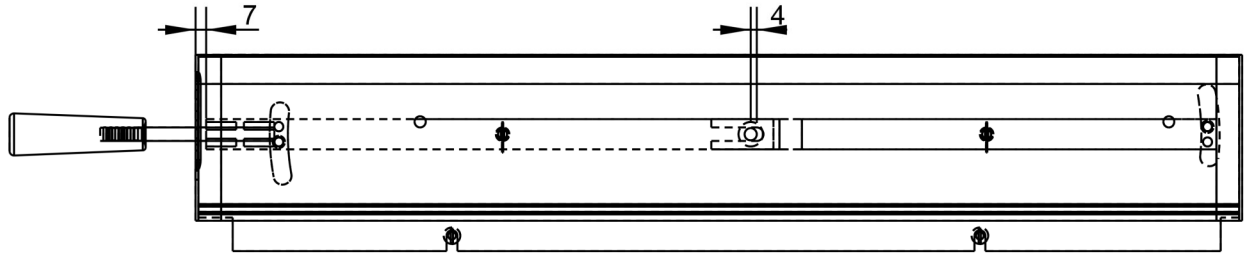
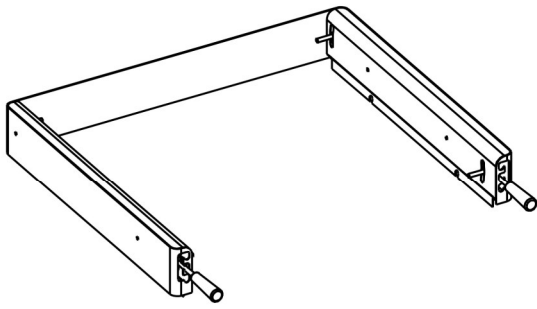

DETALLE B  
ESCALA 1/2

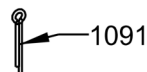

DETALLE A  
ESCALA 1/2

REF.	
O.F.	
QT.	
DEST.	



FAMILIA: COCINAS 2008

MODELO: 4702

DATA:  
09/01/09

DENOMINACION:  
CONJ.ENC.BBQ.MONTADA 800X900

ESCALA:  
1/5

MATERIAL:  
INOX

CODIGO:  
4702-01-M



926/MA/11/05



4785/ER/11/05



QT	COD	DESCRIPCION
4	3326	CASQUILLO PARA SOLDAR
1	470201	ENCIMERA 800X900
1	470178	LATERAL DCHO.SOBRE BBQ.900
1	470179	LATERAL IZQ. SOBRE BBQ.900

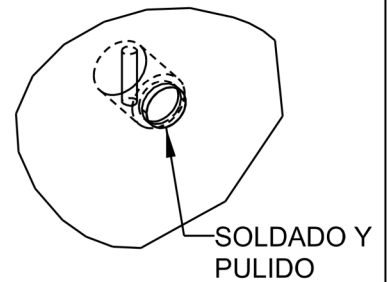
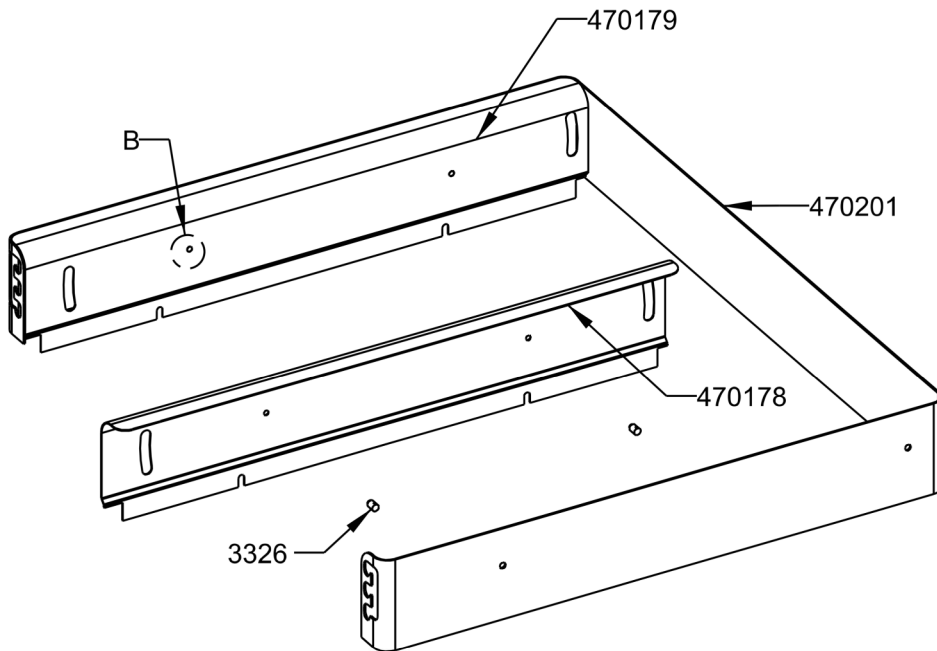
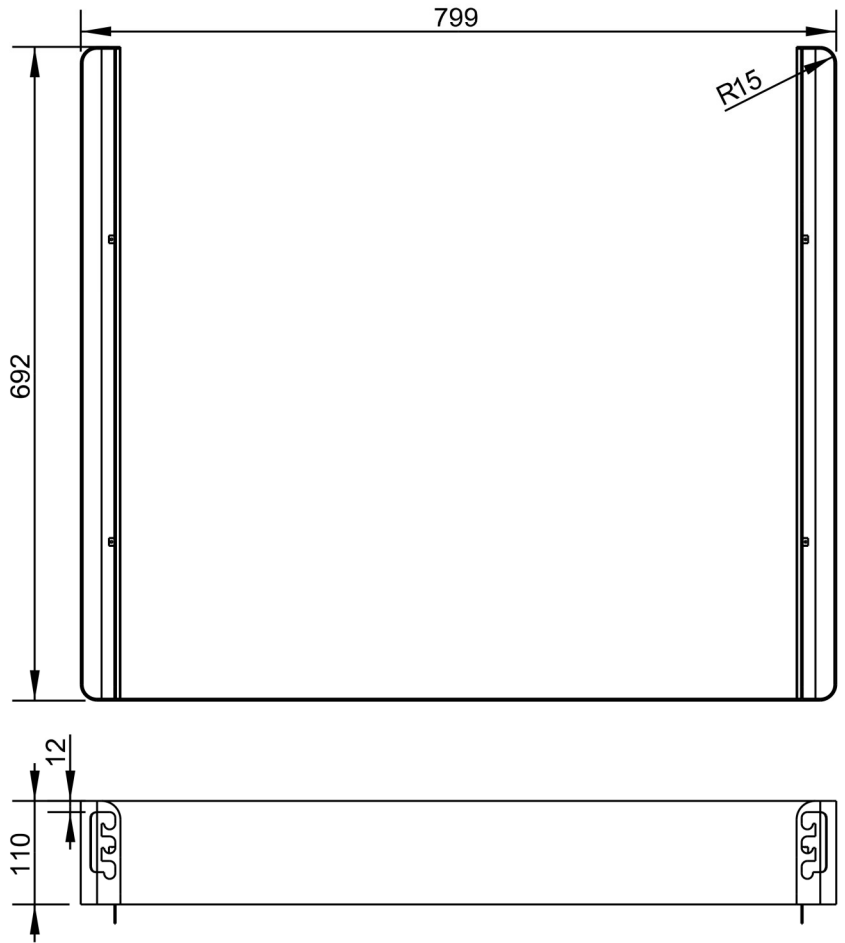
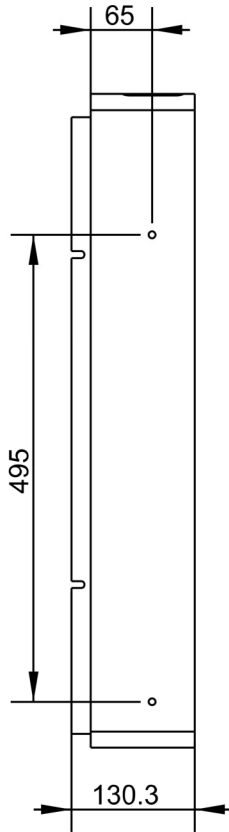

DETALLE B  
ESCALA 1/1

FUNDADA EN 1978  
**MASBAGA**  
REFRIGERACIONES

**EURAST**

**macfrin**

TOLERANCIAS GENERALES: ±0.1 mm

**macfrin**  
group  
**COOKING SYSTEMS,SL**

CONJUNTO SOLDADO Y PULIDO

FAMILIA: COCINAS 2008

MODELO: 4702

REF.	
O.F.	
QT.	
DEST.	

DATA:  
09/01/09

DENOMINACION:  
CONJ.ENC.BBQ.SOLD.800X900

ESCALA:  
1/8

MATERIAL:  
INOX

CODIGO:  
4702-01-C



926/MA/11/05



4785/ER/11/05



QT	COD	DESCRIPCION
3	470448	GUIA REFUERZO PARRILLA CARNE 800
29	470148P	CANAL PARR. CARNE CENT. BBQ 900
1	470248P	CANAL PARR. CARNE LAT. BBQ 900

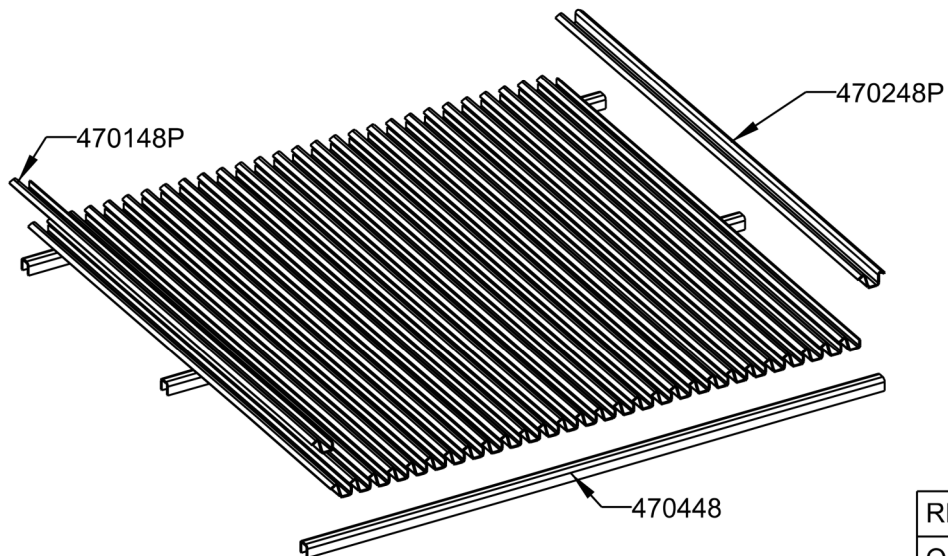
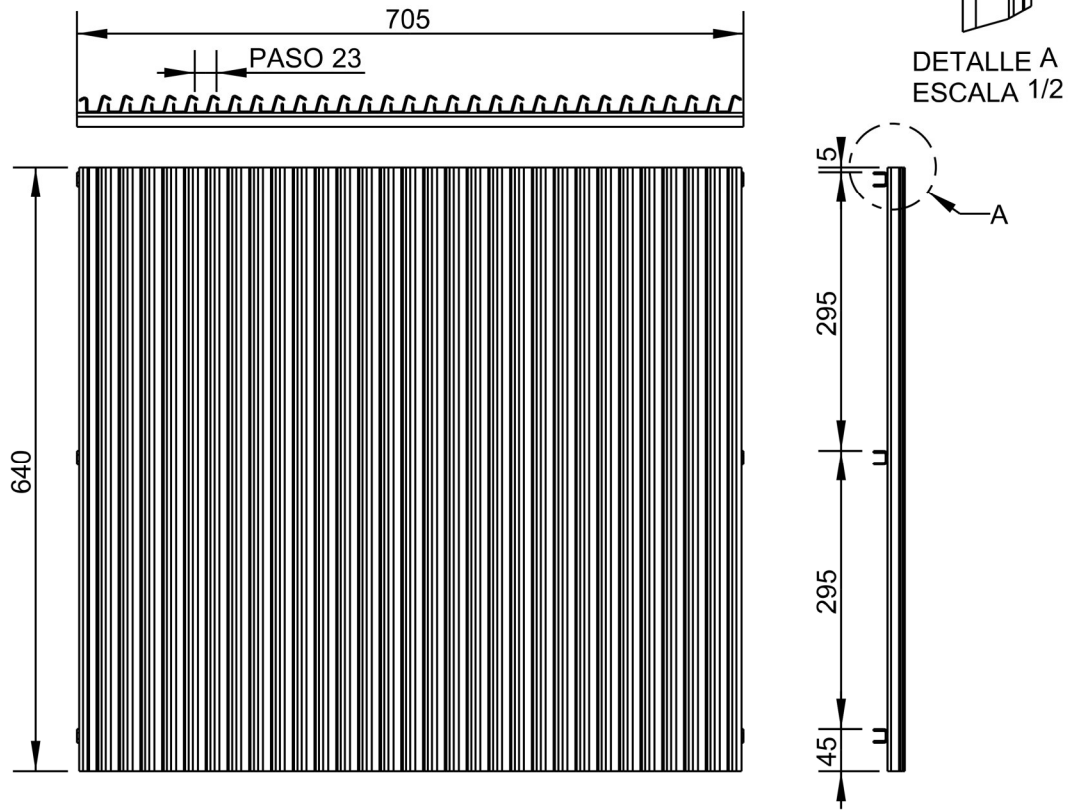

TOLERANCIAS GENERALES:  $\pm 0.1$  mm

SOLDAR TODOS LOS COMPONENTES POR PUNTOS (FUERZA 4)  
USAR PLANTILLA DE ALUMINIO PARA SOLDAR LA ESTRUCTURA



FAMILIA: COCINAS 2008

MODELO: 4702

DENOMINACION:  
PARRILLA CARNE BBQ 800X900

ESCALA:  
1/8

MATERIAL:  
INOX

REF.	
O.F.	
QT.	
DEST.	

DATA:  
08/01/09

CODIGO:  
4702-01-P



926/MA/11/05



4785/ER/11/05



FUNDADA EN 1978  
**MASBAGA**  
SERVICIOS SOCIALES

**EURAST**

**macfrin**

TOLERANCIAS GENERALES: ±0.1 mm

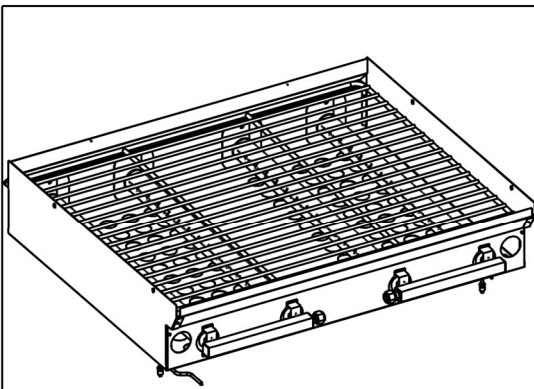

QT	COD	DESCRIPCION
2	3781	TUERCA M16X1.5 D.10
2	3782	BICONO D.10 LATON
8	300187	REGISTRO TRASERO QUEMADOR
2	300388	CORRELLAMAS
1	470216	DEFLECTOR BBQ 800X900
4	361187P	QUEMADOR TUBULAR D.40 L.550
1	470202P	PARRILLA LAVA BBQ 800X900
2	493086PC	COLECTOR 2 SALIDAS HGR
2	C5810129M	PILOTO POLIDORO COMPLETO
4	C5812659	INY.D.120 GLP Q.L.550 / GN Q.L.300
4	C5812679	INYECTOR D.180 GN QUEMADOR L.550

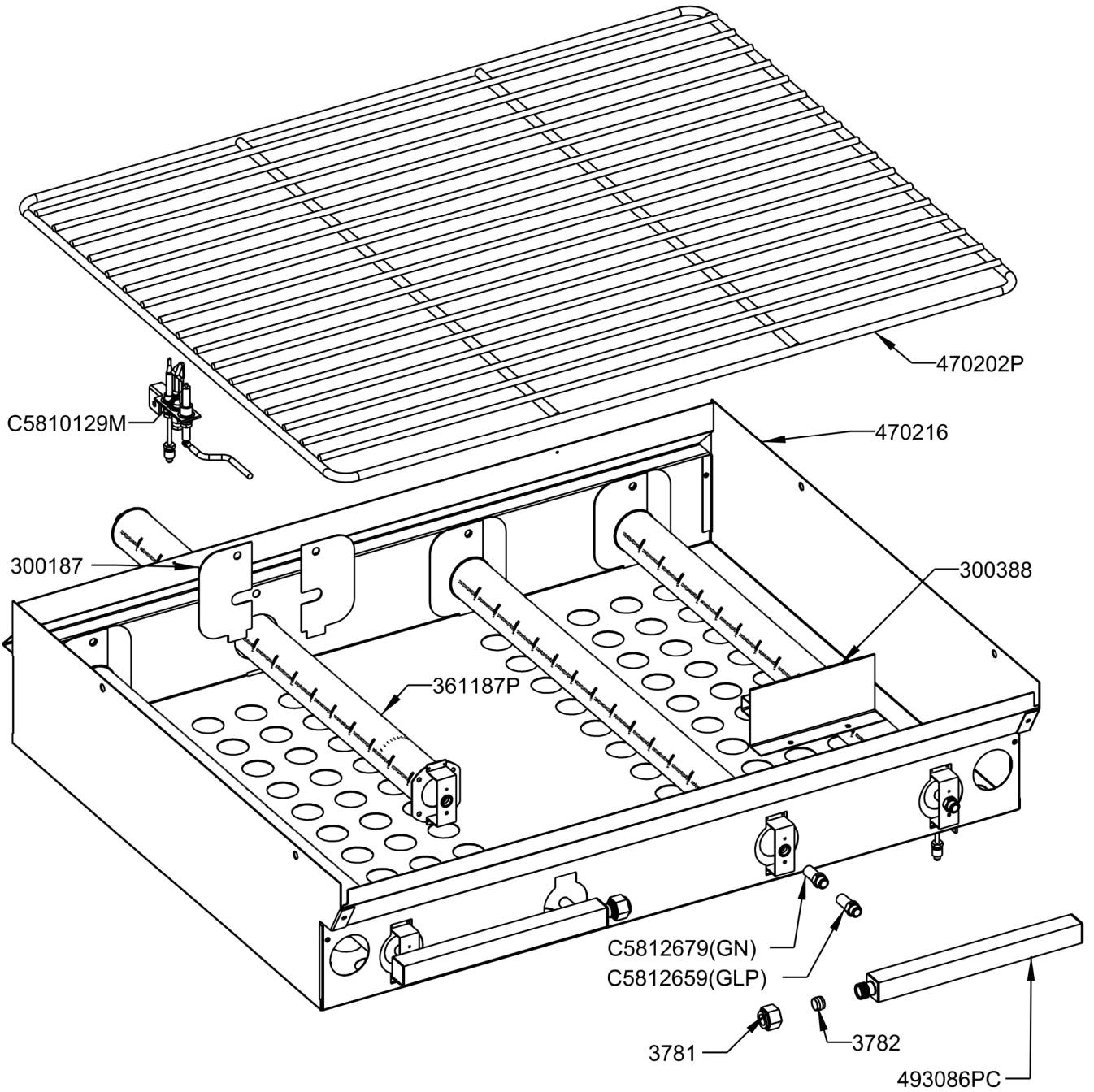

 <b>macfrin</b> group <b>COOKING SYSTEMS,SL</b>	FAMILIA: COCINAS 2008	DATA: 08/01/09	
	MODELO: 4702		
DENOMINACION: DEFLECTOR MONTADO 800X900	ESCALA: 1/5	MATERIAL: INOX	CODIGO: 4702-16-M

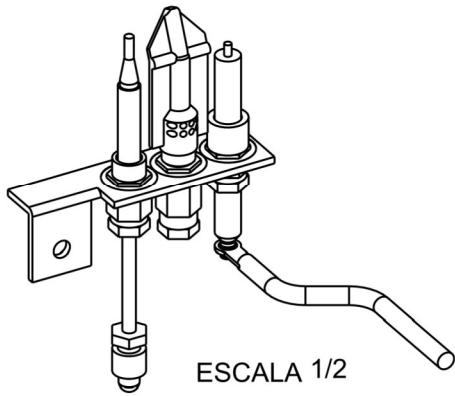

ESCALA 1/2

QT	COD	DESCRIPCION
1	2175	CABLE PIEZO L=760
1	A1018996	RACORD BUJIA
1	A1018997	RACORD PILOTO
1	A1018998	RACORD TERMOPAR
1	A1018999	BICONO PILOTO
1	C5810129	PILOTO POLIDORO
1	C5810139	BUJIA
1	C5810159	INYECTOR PILOTO GN (27.2) 2 AGUJ.
1	C5810169	INYECTOR PILOTO GLP (22) 1 AGUJ.
1	C5811829	TERMOPAR LISO M9X1 L 600

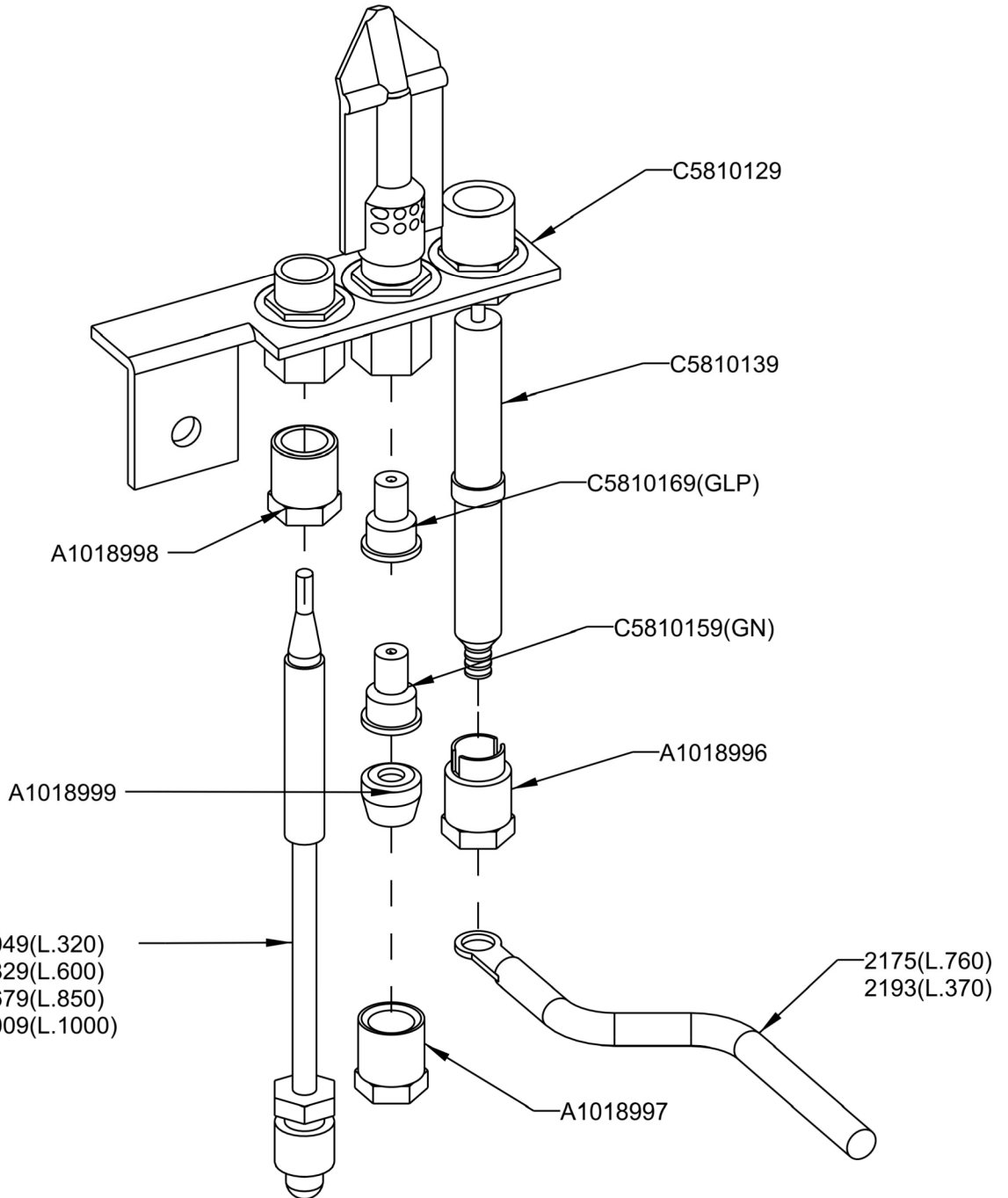

C5820049(L.320)  
 C5811829(L.600)  
 C5811679(L.850)  
 C5811009(L.1000)



926/MA/11/05



4785/ER/11/05



QT	COD	DESCRIPCION
1	300399	TAPA 20X20 C/AGUJERO D.12
1	301399	TAPA 20X20
1	330189	MANGUITO M16X1.5 TUBO D.10
1	493086P	COLECTOR HGR

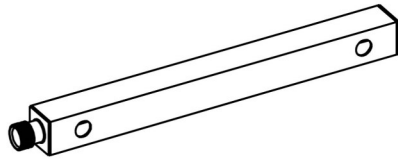

ESCALA 1/4

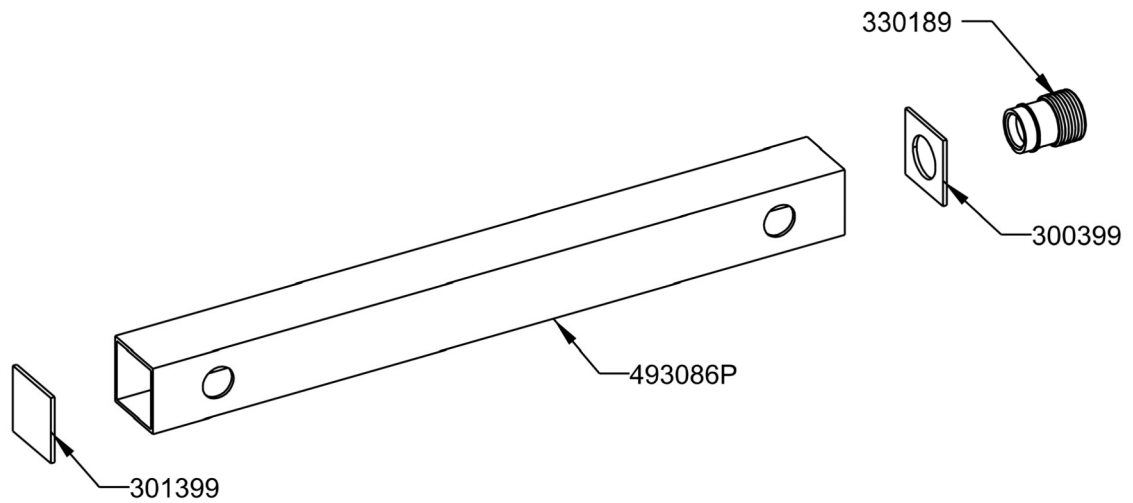
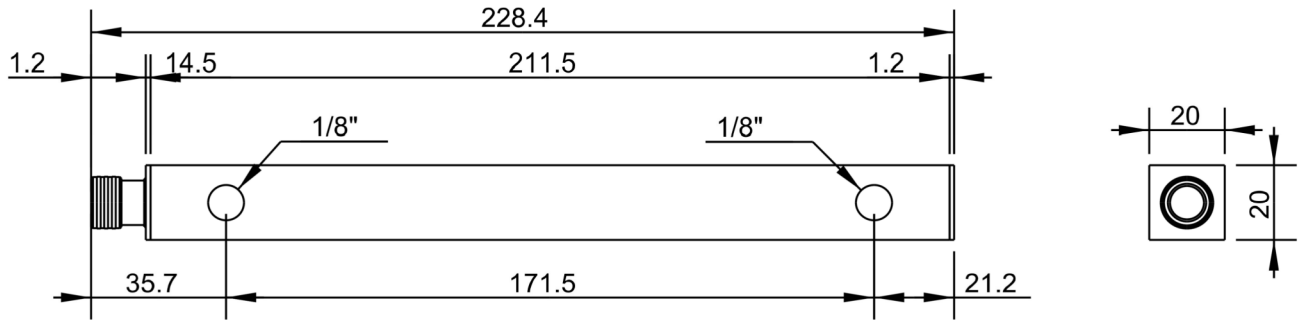

TOLERANCIAS GENERALES: ±0.1 mm

SOLDADURA CONTINUA Y ESTANCA



FAMILIA: COCINAS 2008

MODELO: 4930

REF.	
O.F.	
QT.	
DEST.	

DATA:  
07/10/08

DENOMINACION:  
COLECTOR 2 SALIDAS GAS HGR

ESCALA:  
1/2

MATERIAL:  
FE ZINCADO

PROGRAMA:  
4930-86-PC



926/MA/11/05



4785/ER/11/05



TOLERANCIAS GENERALES: ±0.1 mm

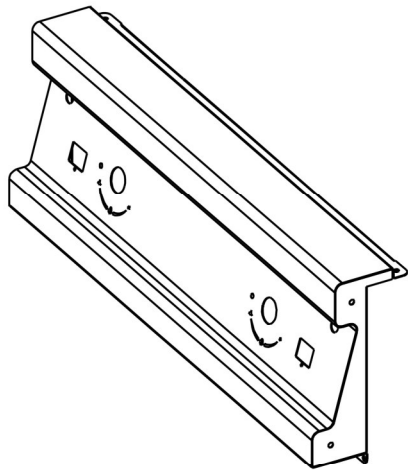

QT	CODIGO	DESCRIPCION
1	350178	TAPETA LATERAL DERECHA FRONTAL
1	350179	TAPETA LATERAL IZQUIEDA FRONTAL
1	470439	FRONTAL MANDOS BBQ 800X750/900
1	470439C	CONJUNTO FRONTAL BBQ 800
6	TESTA35	ANGULO TESTATINA 35
4	TESTA70	ANGULO TESTATINA 70

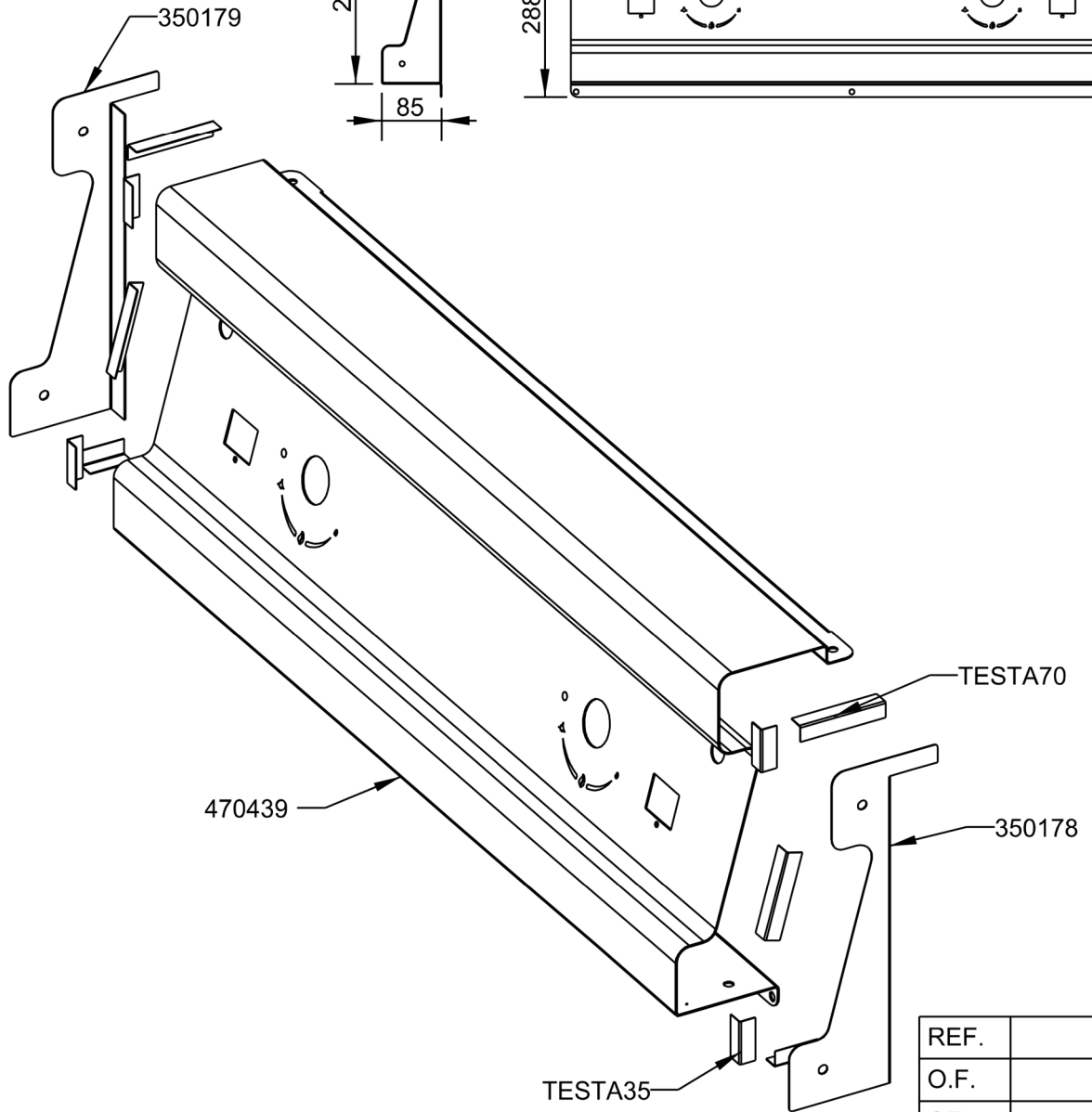
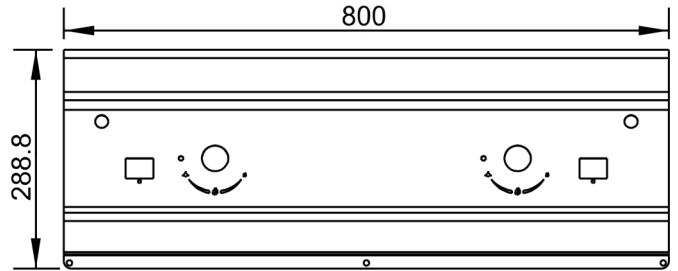
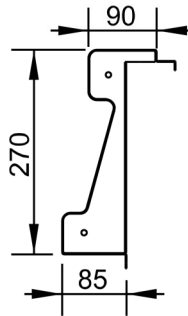

CONJUNTO SOLDADO POR PUNTOS



FAMILIA: COCINAS 2008

MODELO: 4704

DENOMINACION:  
CONJUNTO FRONTAL BBQ 800

ESCALA:  
1/10

MATERIAL:  
INOX

REF.	
O.F.	
QT.	
DEST.	

DATA:  
24/10/08

CODIGO:  
470439C



926/MA/11/05



4785/ER/11/05



QT	COD	DESCRIPCION
1	3781	TUERCA M16X1.5 D.10
1	3782	BICONO D.10 LATON
1	3810	RACORD LATON 90° M-16X1.5
1	C5811429	GRIFO VALVULA COCINA 21S D.1/2"
1	C5815369	TUERCA+BICONLO D.6 M10X1

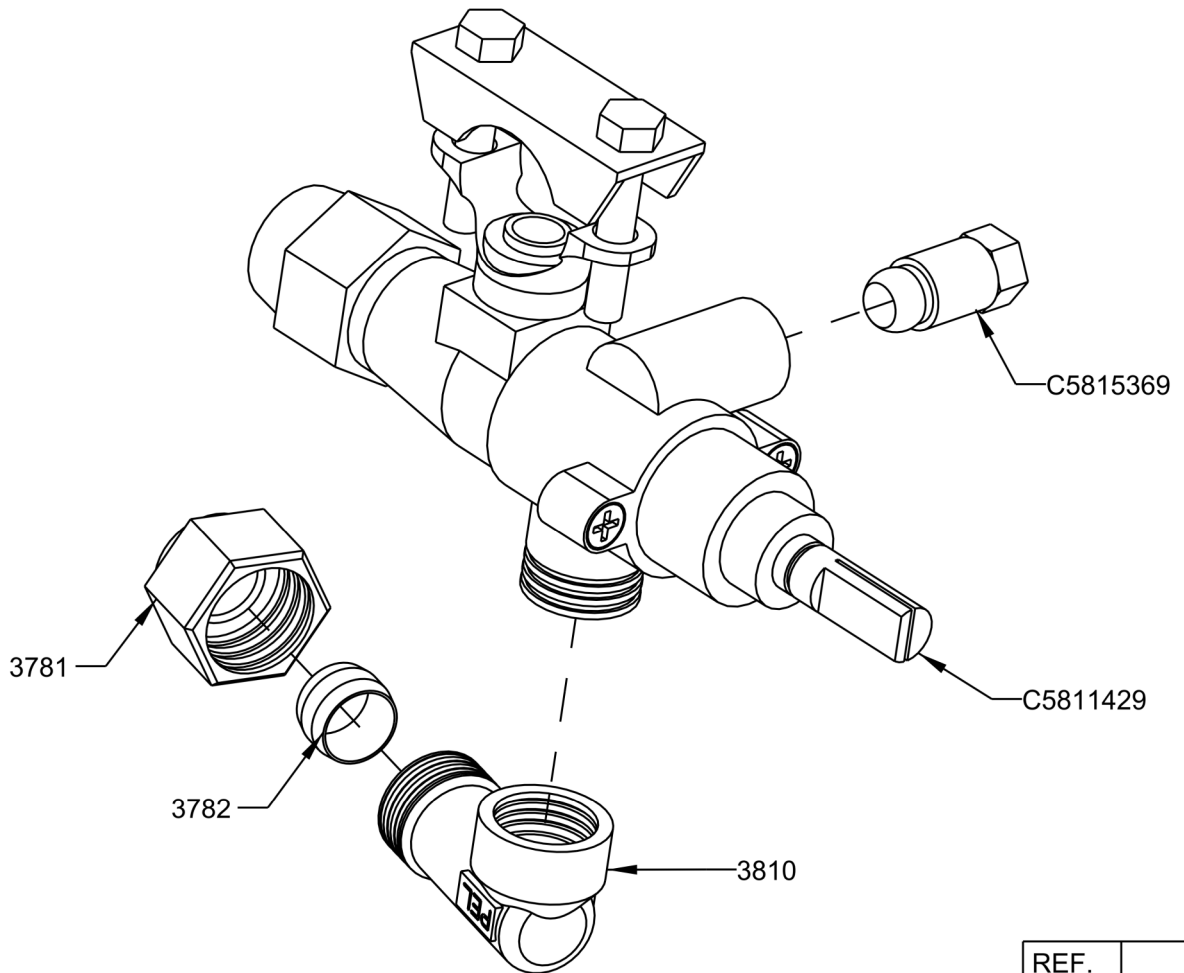
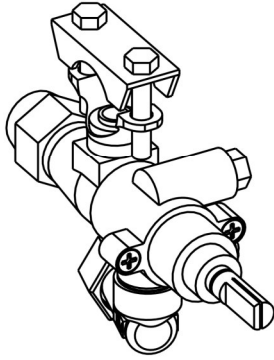

FUNDADA EN 1978  
**MASBAGA**  
BARBERS COOKING

**EURAST**

**macfrin**

TOLERANCIAS GENERALES: ±0.1 mm

**macfrin**  
group  
**COOKING SYSTEMS,SL**

FAMILIA: COCINAS 2008

MODELO: 3401

REF.	
O.F.	
QT.	
DEST.	

DATA:  
05/09/08

DENOMINACION:  
GRIFO COCINA 21-S COMPLETO

ESCALA:  
1/1

MATERIAL:  
LATON

PROGRAMA:  
C5811429M