

Pos.	COD.	Q.tà	DESCRIZIONE	DENOMINATION	DESCRIPTION	BEZEICHNUNG	DESCRIPCIÓN
1	908501	1	BASAMENTO	SOCLE	BASE	UNTERSTRUKTUR	BASE
2	TR0860	4	PIEDINO REGOLABILE	PETIT PIED RÉGABLE	RUBBER LEG	EINSTELLBARESOCKEL	PIÉ REGULABLE
3	908570	1	VASCA STAMPATA	BASSIN	TANK	WANNE	BATEA
4	908508	1	LONGHERONE DX	LONGERON	BACK STAY	LANGSTRAGER	LARGUERO DX
5	908509	1	LONGHERONE SX	LONGERON	BACK STAY	LANGSTRAGER	LARGUERO SX
6	908704	6	CUSCINETTO CON PERNO	ROULEMENT	BEARING	LAGER	COJINETE
7	950315	2	SPESSORE X LONGHERONE	ÉPAISSEUR	THICKNESS	STÄRKE	GRUESO
8	908513	1	CAPOTE COMPLETA	CAPOTE	HOOD	GEHAUSE	CAPOTE
9	908703	2	BUSSOLA PER MANIGLIONE	DOUILLE	BEARING	BUCHSE	BRÚJULA
10	909046	1	MANIGLIONE COMPLETO	POIGNEE	HANDLE	HANDRIFF	MANIJA
11	906066	2	ROTELLA SUPPORTO MOLLA	GALET PIVOTANT	SMALL WHELL	RADCHEN	RUEDA DE SOPORTE RESORTE
12	904796	2	PERNO ROTELLA	PIVOT D'ACCROCHAGE	HOOKING PIN	KUPPLUNGSBOLZEN	PERNO
13	902377	2	TIRANTE MOLLA	TIRANT	CONNECTING ROD	ZUGSTAB	VARILLA RESORTE
14	904137	2	MOLLA SOLLEV. CAPOTE	RESSORT	SPRING	FEDER	RESORTE
15	902035	4	DADO M10 TORN.	ECROU	NUT	MUTTER	TUERCA
16	906055	2	RONDELLA PIANA Ø10	RONDELLE	WASHER	UNTERLEGSCHIEBE	ARANDELA
17	905941	2	RONDELLA GROWER Ø10	RONDELLE	WASHER	UNTERLEGSCHIEBE	ARANDELA GROWER
18	908504	1	SUPPORTO MICRO	SUPPORT MICRO	SUPPORT MICRO	HALTERUNG MIKRO	SOPORTE MICRO
19	909105	1	REED MAGNETICO	REED	REED	REED	REED MAGNÉTICO
20	908706	1	CUSTODIA CON MAGNETE	PROTECTION MAGNETO	COVER MAGNET	MAGNETSCHUTZ	ESTUCHE CON IMÁN
21	908512	2	PIASTRA FISSAGGIO GUIDA	PLAQUE FIXATION GUIDE	PLATE FIXING GUIDES	PLATTE BEFESTIGUNG FÜHRT	PLACA FIJADO GUÍAS
22	908511	2	GUIDA MANIGLIONE	GUIDE DE POIGNÉE	HANDLE GUIDE	HANDGRIFF-FÜHRER	GUÍA DE LA MANIJA
23	908726	4	DISTANZIALE CAPOTE	ENTRETOISE	SPACER	DISTANZSCHEIBE	ESPACIADOR
24	908651	1	COBENTAZIONE FRONTALE VASCA	ISOLATION FRONTALE	FRONTAL INSULATING	FRONTALES ISOLIEREN	AISLAMIENTO FRONTAL
25	909011	1	SCHEDA COMANDI	FICHE COMMANDE	CONTROL CARD	KONTROLLKARTE	FICHA PEDIDO
26	908653	1	COBENTAZIONE CAPOTE	ISOLATION CAPOTE	HOOD INSULATING	GEHAUSE ISOLIEREN	AISLAMIENTO CAPOTE
27	908654	1	CAPPELLO COIBENTAZIONE CAPOTE	COUVERCLE ISOLATION CAPOTE	HOOD INSULATING COVER	GEHASE ISOLIEREN DECKEL	COBERTURA AISLAMIENTO CAPOTE
28	908652	2	COIBENTAZIONE LATERALE DX-SX	ISOLATION LATÉRALE	LATERAL INSULATING	SEITLICHES ISOLIEREN	AISLAMIENTO LATERAL
29	908510	1	TRAVERSA POSTER. SUPERIORE	ENTRETOISE POSTER. SUPÉRIEUR	UPPER BACK CROSSPIECE	OBERER HINTERE DURCHQUERUNG	TRAVESÍA POSTERIOR SUPERIOR
30	908858	1	PANNELLO POSTERIORE	PANNEAU POSTERIEUR	BACK PANEL	HINTERE VERKLEIDUNG	PANEL POSTERIOR
31	908649	1	COBENTAZIONE SUPERIORE VASCA	ISOLATION SUPÉRIEUR BASSIN	UPPER BACK INSULATING TANK	OBERER ISOLIEREN WANNE	AISLAMIENTO SUPERIOR BATEA
32	950316	2	SUPPORTO TIRAGGIO MOLLE	SUPPORT RESSORT	SPRINGS SUPPORT	FRÜHLINGE UNTERSTÜTZUNG	SOPORTE RESORTE
33	907773	2	COPIGLIA 2x30	COUPILLE	SPLIT PIN	SPLINT	CLAVIJA
34	907785	2	VITE FEMMINA M6	VIS	SCREW	SCHRAUBE	TORNILLO
35	903252	2	GUARNIZIONE PIASTRA GUIDA	JOINT	GASKET	DICHTUNG	GUARNICIÓN

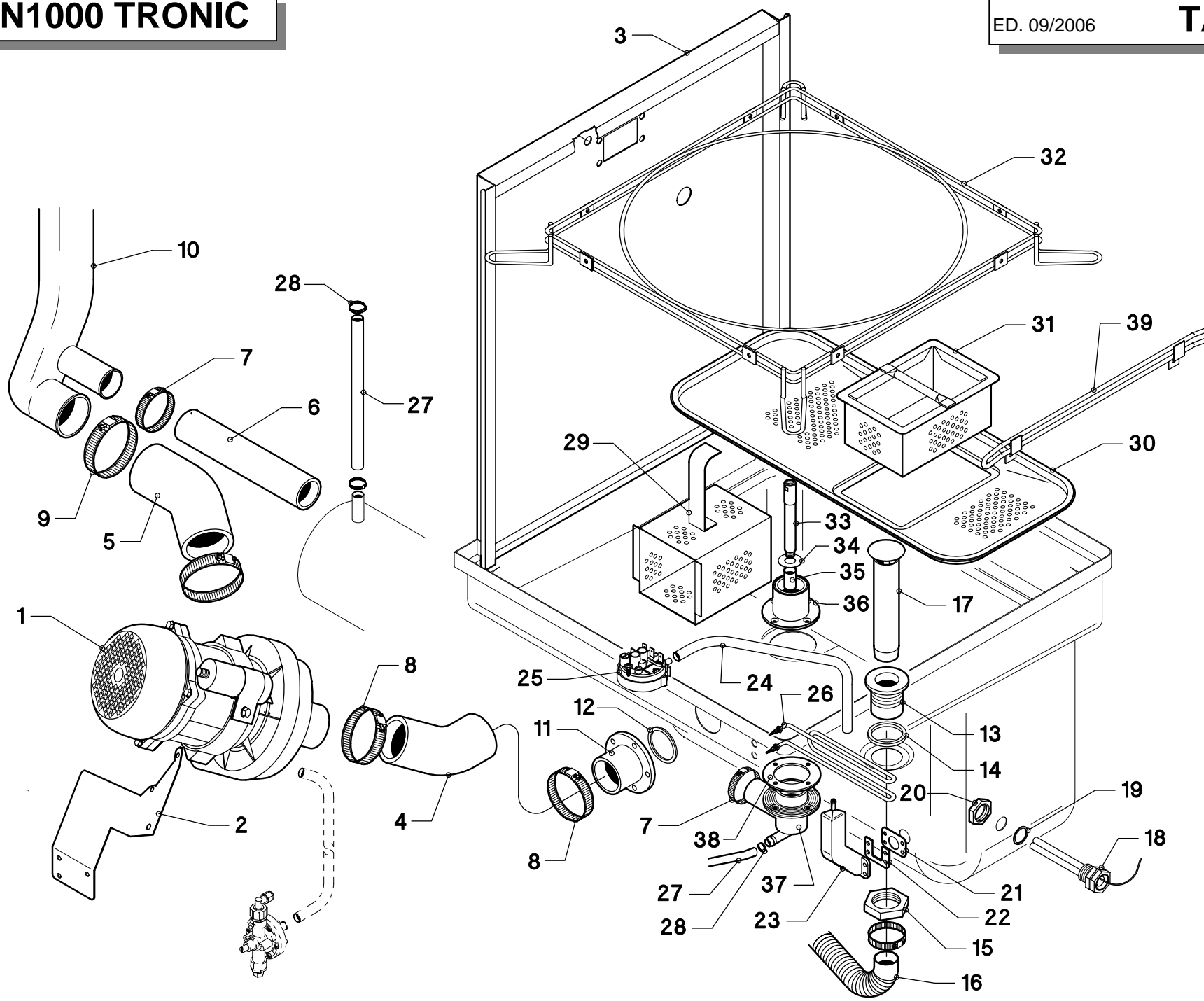

Pos.	COD.	Q.tà	DESCRIZIONE	DENOMINATION	DESCRIPTION	BEZEICHNUNG	DESCRIPCIÓN
1	902293	1	POMPA	POMPE	PUMP	PUMPE	BOMBA
2	908575	1	SUPPORTO POMPA	SUPPORT POMPE	PUMP SUPPORT	PUMPE TRÄGER	SOPORTE BOMBA
3	908516	1	SCHIENALE	STRUCURE POSTERIEUR	BACK FRAME WORK	GEFÜGE	RESPALDO
4	908742	1	MANICOTTO ASPIRAZIONE	MANCHON D'ASPIRATION	INLET ELBOW	ANSAUGMUFFE	PALANCA DE ASPIRACIÓN
5	908746	1	TUBO MANDATA	MANCHON DE REFAULEM.	OUTLET ELBOW	AUSLAMUFFE	PALANCA DE MANDO
6	908709	1	TUBO MANDATA LAVAGGIO INFER.	TUYAU DE LAVAGE INF.	LOWER WASHING PIPE	UNTERER SPÜLUNG SAÜLE	TUBO LAVADO INFERIOR
7	902441	2	FASCETTA Ø 38÷50	COLLIER	CLAMP	SCHELLE	ABRAZADERA
8	902490	2	FASCETTA Ø 58÷75	COLLIER	CLAMP	SCHELLE	ABRAZADERA
9	902480	2	FASCETTA Ø 44÷56	COLLIER	CLAMP	SCHELLE	ABRAZADERA
10	908747	1	COLONNA LAVAGGIO	COLONNE DE LAVAGE	WASHING PIPE	SPÜLUNG SAÜLE	COLUMNA LAVADO
11	901653	1	RACCORDO ASPIRAZIONE	RACCORD D'ASPIRATION	INTAKE PIPE FITTING	ANSAUGANSCHLUSSE	EMPALME DE ASPIRACIÓN
12	904395	1	O-RING	O-RING	O-RING	O-RING	O-RING
13	905450	1	RACCORDO SCARICO	RACCORD DÉCHARGÉ	PIPE FITTING FOR OUTLET	ABLAUFANSCHLUSS	EMPALME DESAGOTE
14	904380	1	O-RING	O-RING	O-RING	O-RING	O-RING
15	902080	1	GHIERA 1" ¼ GAS	VIROLE	LOCK-NUT	NUT MUTTER	ABRAZADERA
16	907451	1	TUBO DI SCARICO	TUYAU DE DÉCHARGÉ	OUTLET HOSE	ABLAUFSCHLAUCH	TUBO DESAGOTE
17	907329	1	TROPPO PIENO	NIVEAU	OVER FLOW	VEBERLAUF	DAMISIADO LLENO
18	TR0298	1	PORTABULBO	SIEGE DE BULBE	SEATING BULB	KUGEL SITZ	PORTABULBO
19	903250	1	GUARNIZIONE 1/2" GAS	JOINT	GASKET	DICHTUNG	GUARNICIÓN
20	902061	1	GHIERA 1/2" GAS	VIROLE	LOCK NUT	NUT MUTTER	ABRAZADERA
21	903261	1	GUARNIZIONE TRAPPOLA ARIA	JOINT RESERVOIR AIR	AIR TRAP GASKET	DICHTUNG LUFTFALLE	GUARNICIÓN TRAMPA DEL AIRE
22	907926	1	PIASTRINA TRAPPOLA ARIA	PLAQUETTE RESERVOIR AIR	AIR TRAP LINK	GLIED LUFTFALLE	PLANCHA TRAMPA DEL AIRE
23	907254	1	TRAPPOLA ARIA	RESERVOIR AIR	AIR TRAP	LUFTFALLE	TRAMPA DEL AIRE
24	907279	1	TUBO PRESSOSTATO	TUYAU PRESSOSTAT	PRESSURE SWITCH PIPE	SCHLAUCH	TUBO PRESÓSTATO
25	905271	1	PRESSOSTATO	PRESSOSTAT	PRESSURE SWITCH	DRUCHWAECHTE	PRESOSTATO
26	905748	1	RESISTENZA 3000W	RESISTANCE	HEATING ELEMENT	HEIZKÖRPER	RESISTENCIA
27	907295	2	TUBO GOMMA 12 x 19,5	TUYAU EN CAOUTCHOUC	RUBBER HOSE	GUMMISCHLAUCH	TUBO GOMA
28	902440	3	FASCETTA Ø 13÷20	COLLIER	CLAMP	SCHELLE	ABRAZADERA
29	906710	1	FILTRO ASPIRAZIONE POMPA	FILTRE D'ASPIRATION	INTAKE FILTER	ABLAUF FILTER	FILTRO DE ASPIRACIÓN
30	906703	1	FILTRO VASCA	FILTRE BASSIN	TANK FILTER	FILTER WANNE	FILTRO BATEA
31	906704	1	FILTRO A CASSETTO	TIROIR FILTRE	DRAWER FILTER	FACH-FILTER	FILTRO A CAJÓN
32	908708	1	TELAIO PORTACESTELLI	CHASSIS PORTE PANIER	TRACK	FÜHRUNG	BASTIDOR
33	908734	1	PERNO RISCIAQUO INFERIORE	TOURILLON DE RINÇAGE INFER.	INFERIOR RINSE PIN	UNTERSPELLSTIFT	PERNO ENJUAGUE INFERIOR
34	906004	1	RONDELLA	RONDELLE	WASHER	UNTERLEGSCHIEBE	ARANDELA
35	908456	1	BOCCOLA RIDUZIONE	RÉDUCTION	REDUCTION BUSH	VERKLEINERUNG	REDUCCIÓN
36	905388	1	RACCORDO INFER. LAVAGGIO	RACCORD DE LAVAGE INFER.	WASHING INFER. PIPE FITTING	UNTERANSCHLUSS WASCHEN	EMPALME INFER. DE LAVADO
37	905449	1	MOZZO LAVAGGIO/RISCIAQUO	MOYEU DE LAVAGE/RINÇAGE	WASHING/RINSE HUB	SPÜLUNG/NASCHSPÜLUNG NABE	BUJE DE LAVADO/ENJUAGUE
38	908141	1	GUARNIZIONE	JOINT	GASKET	DICHTUNG	GUARNICIÓN
39	901672	1	GUIDA PORTACESTELLO	COULISSE PANIER	BASKET GUIDE	KORBÜFHRUNG	GUIA CANASTOS

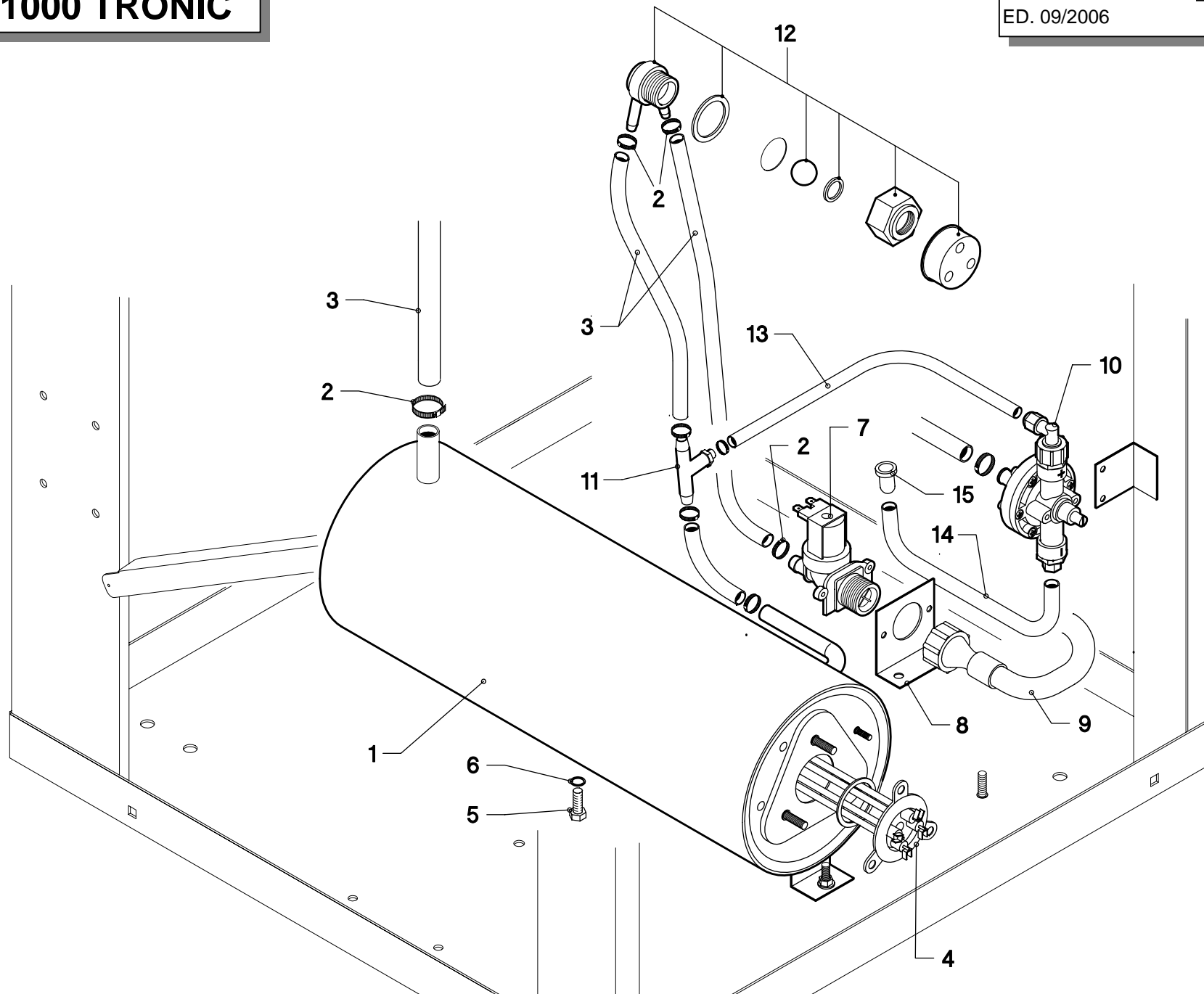

Pos.	COD.	Q.tà	DESCRIZIONE	DENOMINATION	DESCRIPTION	BEZEICHNUNG	DESCRIPCIÓN
1	900485	1	BOILER	CHAUFFE EAU	BOILER	HEISSWASSERSPEICHER	BOILER
2	902440	7	FASCETTA Ø 13÷20	COLLIER	CLAMP	SHELLE	ABRAZADERA
3	907295	4	TUBO GOMMA 12x19,5	TUYAU EN CAOUTCHOUC	RUBBER HOSE	GUMMISCHLAUCH	TUBO GOMA
4	905570	1	RESISTENZA 6KW + O-RING	RESISTANCE + O-RING	HEATING ELEMENT + O-RING	HEIZKÖRPER + O-RING	RESISTENCIA + O-RING
5	907820	1	VITE	VIS	SCREW	SCHRAUBE	TORNILLO
6	904430	1	O-RING TAPPO BOILER	O-RING BOUCHON	O-RING PLUG	O-RING FROPFEN	O-RING TAPÓN
7	902390	1	ELETTRIVALVOLA	SOUPAPE ELECTRIQUE	ELECTRIC VALVE	ELEKTROVENTIL	VALVULA ELETRICA
8	906365	1	SUPPORTO ELETTRIVALVOLA	PALIER SOUPAPE ELECTRIQUE	BEARING ELECTRIC VALVE	TRÄGE ELEKTROVENTIL	SOPORTO VALVULA ELETRICA
9	907345	1	TUBO CARICO ACQUA	TUYAN D'ENTRÉE DE L'EAU	INLET PIPE	WASSERZUFÜHRROHR	TUBO
10	902018	1	DOSATORE POMPA	DOSEUR POMPE	PUMP DOSING DEVICE	DOSIERSATZ PUMPE	DOSIFICADOR BOMBA
11	905408	1	RACCORDO A 3 VIE	RACCORD	PIPE FITTING	ANSCHLUSSE	EMPALME
12	TR2433	1	VALVOLA ANTIRIFLUSSO	VALVE	VALVE	VENTIL	VALVULA
13	907279	1	TUBO 4 x 7	TUYAU	PIPE	SCHLAUCH	TUBO
14	907278	1	TUBO 4 x 7	TUYAU	PIPE	SCHLAUCH	TUBO
15	902568	1	FILTRO DOSATORE	FILTRE DOSEUR	FILTER FOR DOSING	FILTER	FILTRO DOSIFICADOR

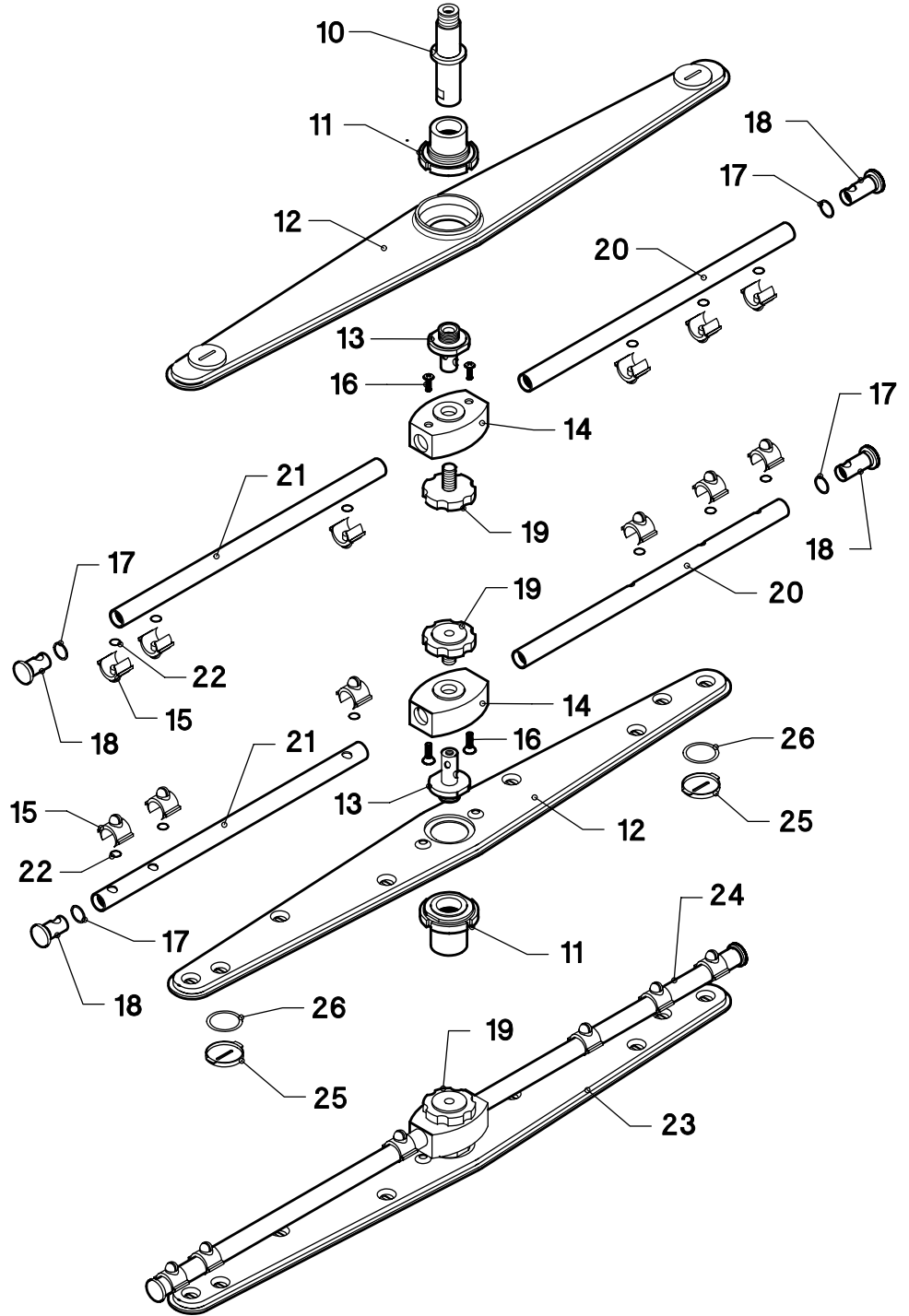
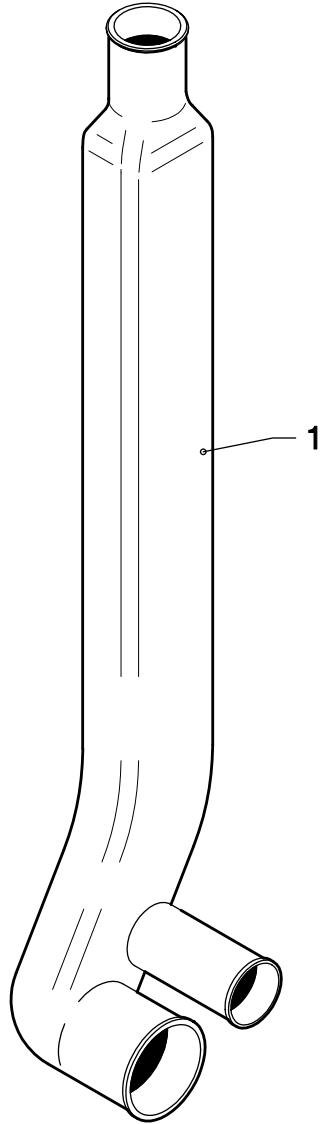
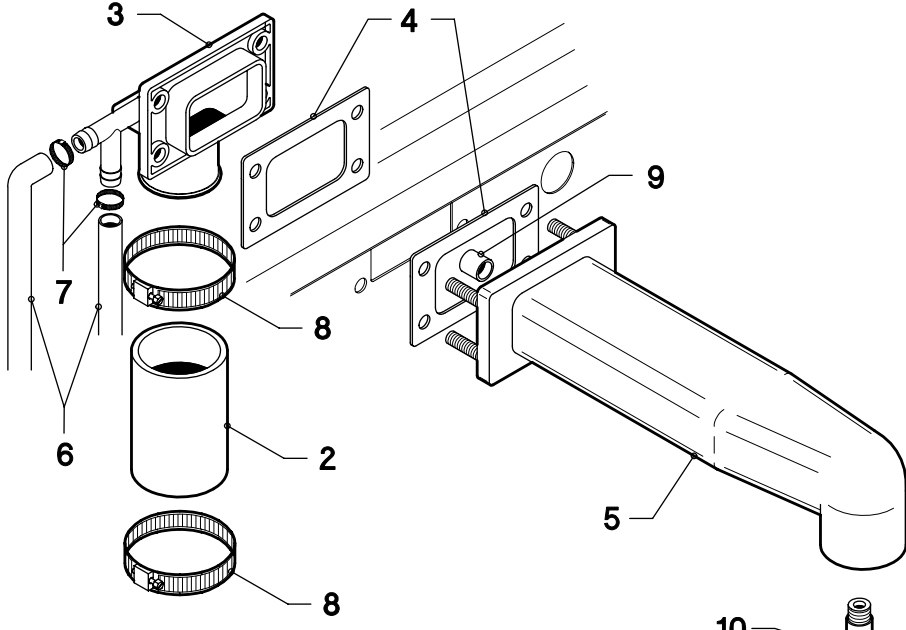

Pos.	COD.	Q.tà	DESCRIZIONE	DENOMINATION	DESCRIPTION	BEZEICHNUNG	DESCRIPCIÓN
1	908747	1	COLONNA LAVAGGIO	COLONNE DE LAVAGE	WASHING PIPE	SPÜLUNG SAÜLE	COLUMNNA LAVADO
2	903706	1	MANICOTTO	MANCHON	ELBOW	MUFFE	PALANCA
3	908745	1	RACCORDO BRACCIO	RACCORD	PIPE FITTING	ANSCHLUSSE	EMPALME
4	903413	2	GUARNIZIONE COLONNA LAVAGGIO	JOINT COLONNE DE LAVAGE	WASHING PIPE GASKET	SPÜLUNG SAÜLE DICHTUNG	GUARNICIÓN COLUMNNA LAVADO
5	908743	1	BRACCIO LAVAGGIO	BRAS DE LAVAGE	WASHING ARM	WASCHLAUFRAD	BRAZO LAVADO
6	907295	2	TUBO GOMMA 12 x 19,5	TUYAU EN CAOUTCHOUC	RUBBER HOSE	GUMMISCHLAUCH	TUBO GOMA
7	902440	2	FASCETTA Ø 13÷20	COLLIER	CLAMP	SHELLE	ABRAZADERA
8	902480	2	FASCETTA Ø 44÷56	COLLIER	CLAMP	SHELLE	ABRAZADERA
9	903379	1	GUARNIZIONE	JOINT	GASKET	DICHTUNG	GUARNICIÓN
10	904765	1	PERNO RISCIA SCUO SUPERIORE	TOURILLON DE RINÇAGE SUPER.	UPPER RINSE PIN	OBERER SPÜLLSTIFT	PERNO ENJUAGUE SUPERIOR
11	904277	2	MOZZO + GHIERA	MOYEU + VIROLE	HUB + RING-NUT	NABE + KLEMMUTTER	BUJE + ABRAZADERA
12	902908	2	GIRANTE LAVAGGIO	BRAS DE LAVAGE	WASH ARM	SPÜLLARM	RODETE LAVADO
13	904760	2	PERNO GIRANTE RISC.	TOURILLON DE RINÇAGE	RINSE PIN	SPÜLLSTIFT	PERNO RODETE ENJUAGUE
14	904292	2	MOZZO GIRANTE RISC.	MOYEU	HUB	NABE	BUJE RODETE ENJUAGUE
15	902816	12	GETTO RISCIA SCUO	JET DE RINÇAGE	RINSING JET	SPÜLLDUSE	CHORRO ENJUAGUE
16	907651	4	VITE TPS M 4x8	VIS	SCREW	SCHRAUBE	TORNILLO
17	904321	4	O-RING	O-RING	O-RING	O-RING	O-RING
18	906450	4	TAPPO PER BRACCIO RISC.	BOUCHON BRAS DE RINÇAGE	PLUG FOR RINSE ARM	VERSCHLUSS SPÜLLAUF	TAPÓN PARA BRAZO ENJUAGUE
19	902880	2	GHIERA BLOCCAGGIO	FRETTE DE BLOCAGE	RING-NUT	KLEMMUTTER	ABRAZADERA BLOQUEO
20	954806	2	BRACCIO RISCIA SCUO DX	BRAS DE RINÇAGE DROITE	RIGHT RINSE ARM	RECHTE SPÜLLAUFRAD	BRAZO ENJUAGUE DERECHO
21	954807	2	BRACCIO RISCIA SCUO SX	BRAS DE RINÇAGE GAUCHE	LEFT RINSE ARM	LINKE SPÜLLAUFRAD	BRAZO ENJUAGUE IZQUIERDO
22	904388	12	O-RING	O-RING	O-RING	O-RING	O-RING
23	903107	2	GIRANTE LAVAGGIO COMP.	BRAS DE LAVAGE COMPL.	COMPL. WASH ARM	SPÜLLARM KOMPL.	RODETE LAVADO COMPL.
24	903017	2	GIRANTE RISCIA SCUO COMP.	BRAS DE RINÇAGE COMPL.	COMPL. RINSE ARM	SPÜLLSTIFT KOMPL.	RODETE ENJUAGUE COMP.
25	906445	4	TAPPO ISPEZIONE	BOUCHON	PLUG	FROPFEN	TAPÓN
26	904324	4	O-RING TAPPO ISPEZIONE	O-RING	O-RING	O-RING	O-RING

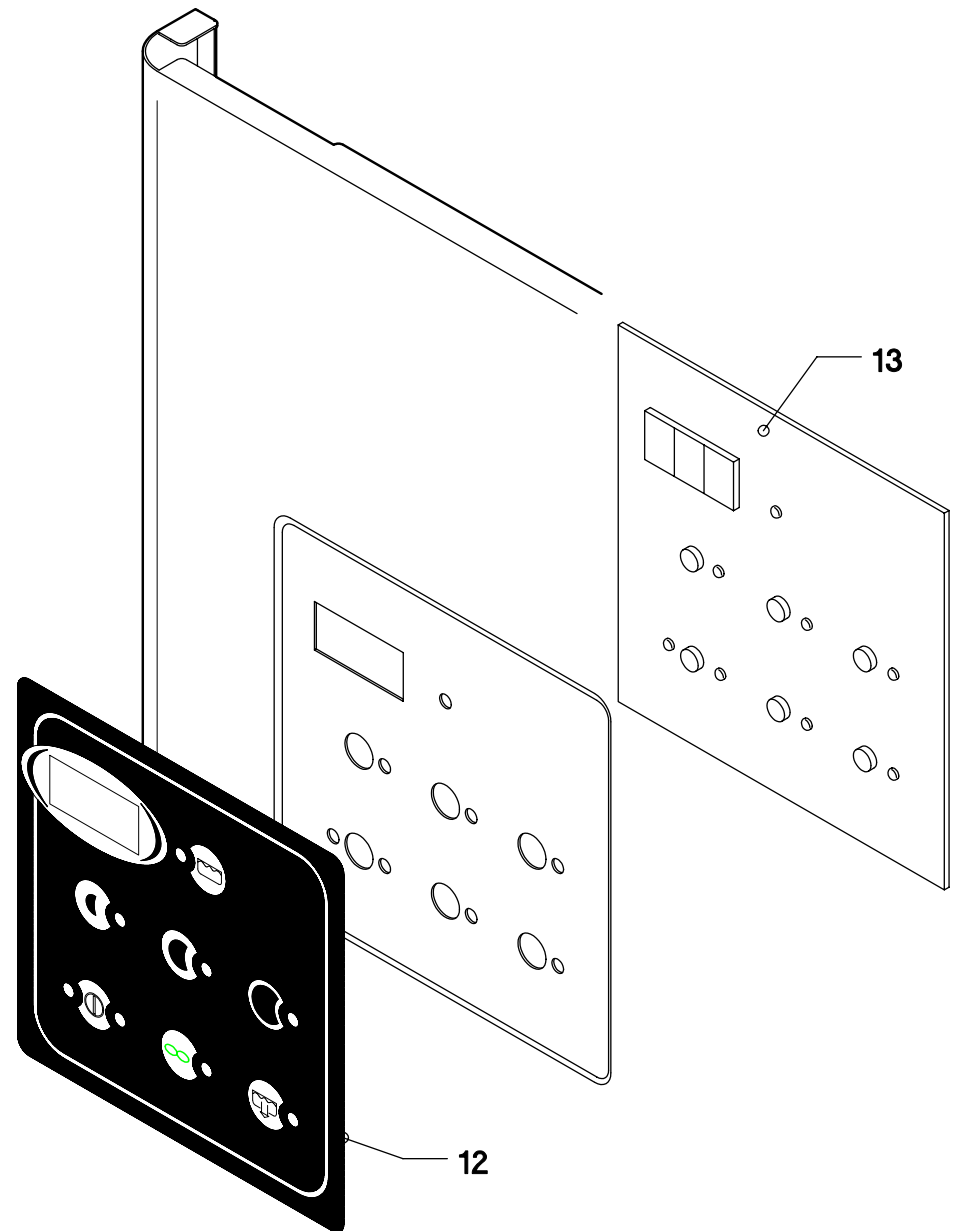
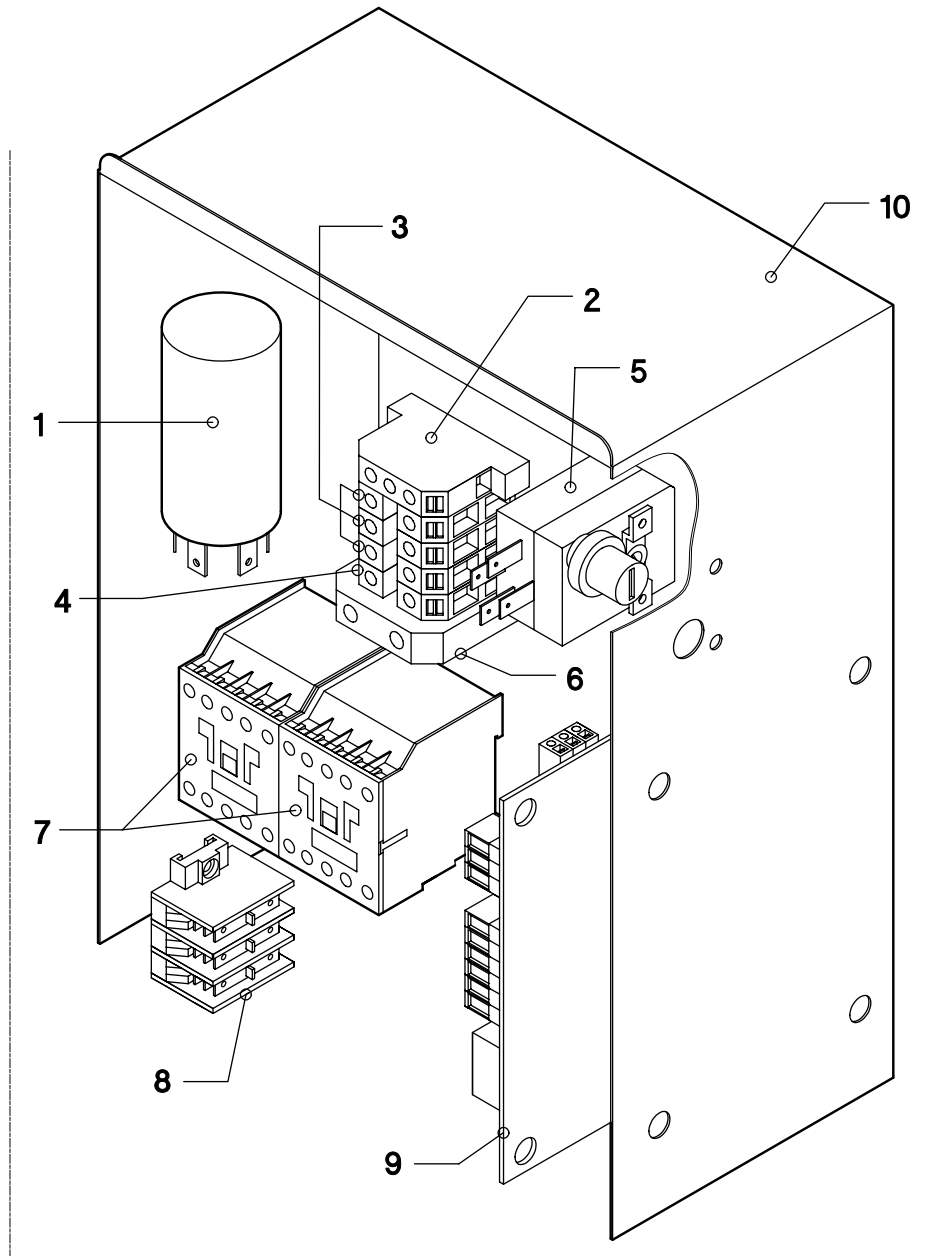

Pos.	COD.	Q.tà	DESCRIZIONE	DENOMINATION	DESCRIPTION	BEZEICHNUNG	DESCRIPCIÓN
1	902107	1	FILTRI ANTIDISTURBO	FILTRE ANTIDERANGEMENT	NOISE FILTER	ENTSTORFILTER	FILTROS DE RUIDOSIDAD
2	904163	1	MORSETTO 1P	BORNE	TERMINAL	KLEMMLEISTE	GRAMPA
3	TR3178	1	MORSETTO 3P	BORNE	TERMINAL	KLEMMLEISTE	GRAMPA
4	904166	1	MORSETTO 1P	BORNE	TERMINAL	KLEMMLEISTE	GRAMPA
5	907125	1	TERMOSTATO DI SICUREZZA	THERMOSTAT	THERMOSTAT	THERMOSTAT	TERMÓSTATO DE SEGURIDAD
6	904175	1	FERMA MORSETTO	ARRÊTÉE BORNE	TERMINAL BLOCK	KLEMMENBLOCK	BLOQUE GRAMPA
7	907095	2	TELERUTTORE	TELERUPTEUR	CONTACTOR	SCHUTZ	TELERRUPTOR
8	955068	1	MORSETTO PA80	BORNES	TERMINAL BOARD	KLEMMLEISTE	TABLEROS DE BORNES
9	909012	1	SCHEDA ELETTRONICA CPU	FICHE ÉLECTRONIQUE CPU	CPU CARD	CPU KARTE	FICHA ELECTRÓNICA CPU
10	908750	1	CASSETTA ELETTRICA	BOITE ELECTRIQUE	CABINET	SCHALTKASTEN	CAJA ELÉCTRICA
11	908691	1	QUADRO ELETTRICO	TABLEAU ELECTRIQUE	SWITCHBOARD	SCHALTAFEL	TABLERO ELÉCTRICO
12	909134	1	TARGA	PLAQUETTE	PLATE	SCHILD	PLACA
13	909011	1	SCHEDA COMANDI	FICHE COMMANDE	CONTROL CARD	KONTROLLKARTE	FICHA PEDIDO