



Applus®
LGAI
Organismo Notificado
0370

AENOR
Organismo Notificado
0099

FUNDADA EN 1878
MAS BAGA
GRANDES COCINAS

EURAST

mac-fin

TOLERANCIAS GENERALES: ± 0.5 mm

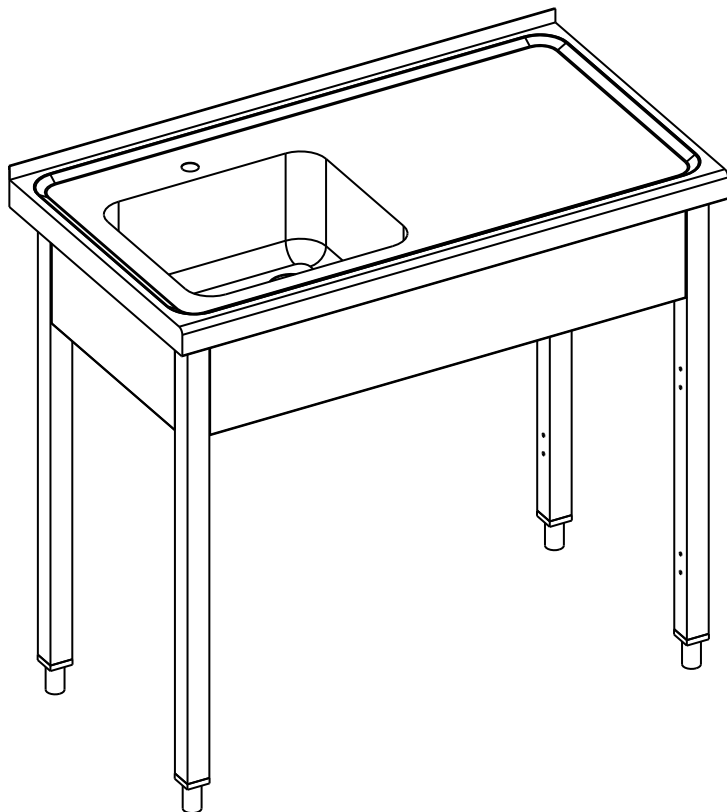
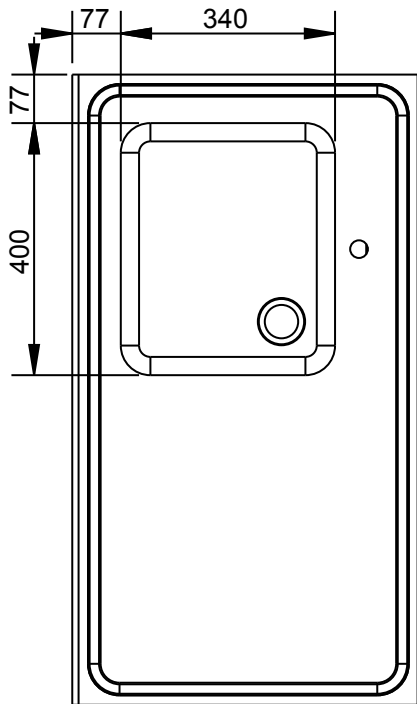
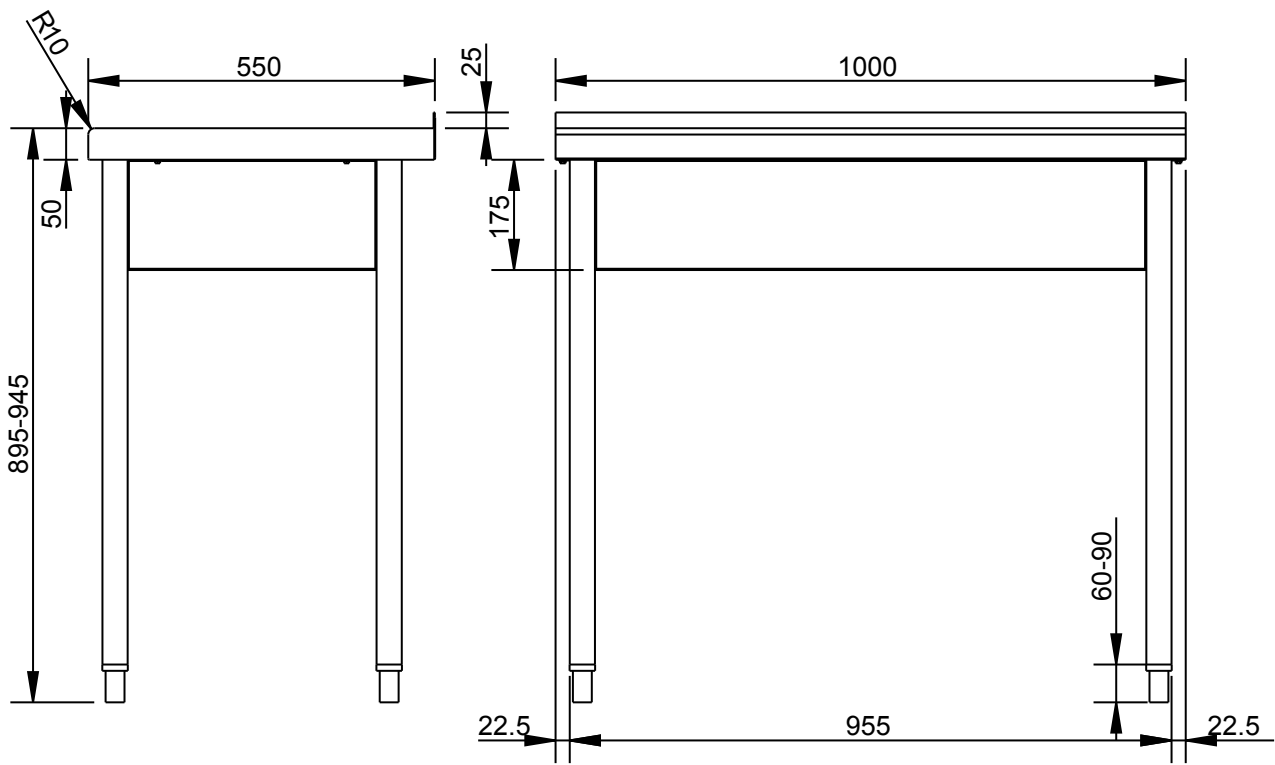

FAMILIA: NEUTRO 2008

FECHA: 30/03/11

MODELO: 209/1

PESO(Kg): 18.009

DENOMINACION:
FREGADERO S/IZQ. 1000x550

ESCALA:
1/12

MATERIAL:
INOX

CODIGO:
2091



Applus®
LGA1
Organismo Notificado
0370

AENOR
Organismo Notificado
0099



TOLERANCIAS GENERALES: ± 0.5 mm

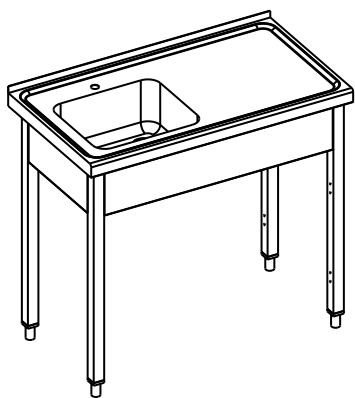

QT	COD	DESCRIPCION
2	209140	FRISO LATERAL FREGADERO
2	209165	FRISO FREGADERO FRONT/TRASERO
2	171208P	PATA DEL.DCHA./TRAS.IZQ.
2	171209P	PATA DEL.IZQ./TRAS.DCHA.
1	920901C	CONJ.FREGADERO S/IZQ.1000x550
4	C1062003	TORNILLO M-5X15 DIN933 ZN
16	C1064063	TORNILLO M-6X15 DIN933 ZN
4	C1260053	ARANDELA M-5 DIN-125 ZN
16	C1260243	ARANDELA M-6 DIN-125 ZN

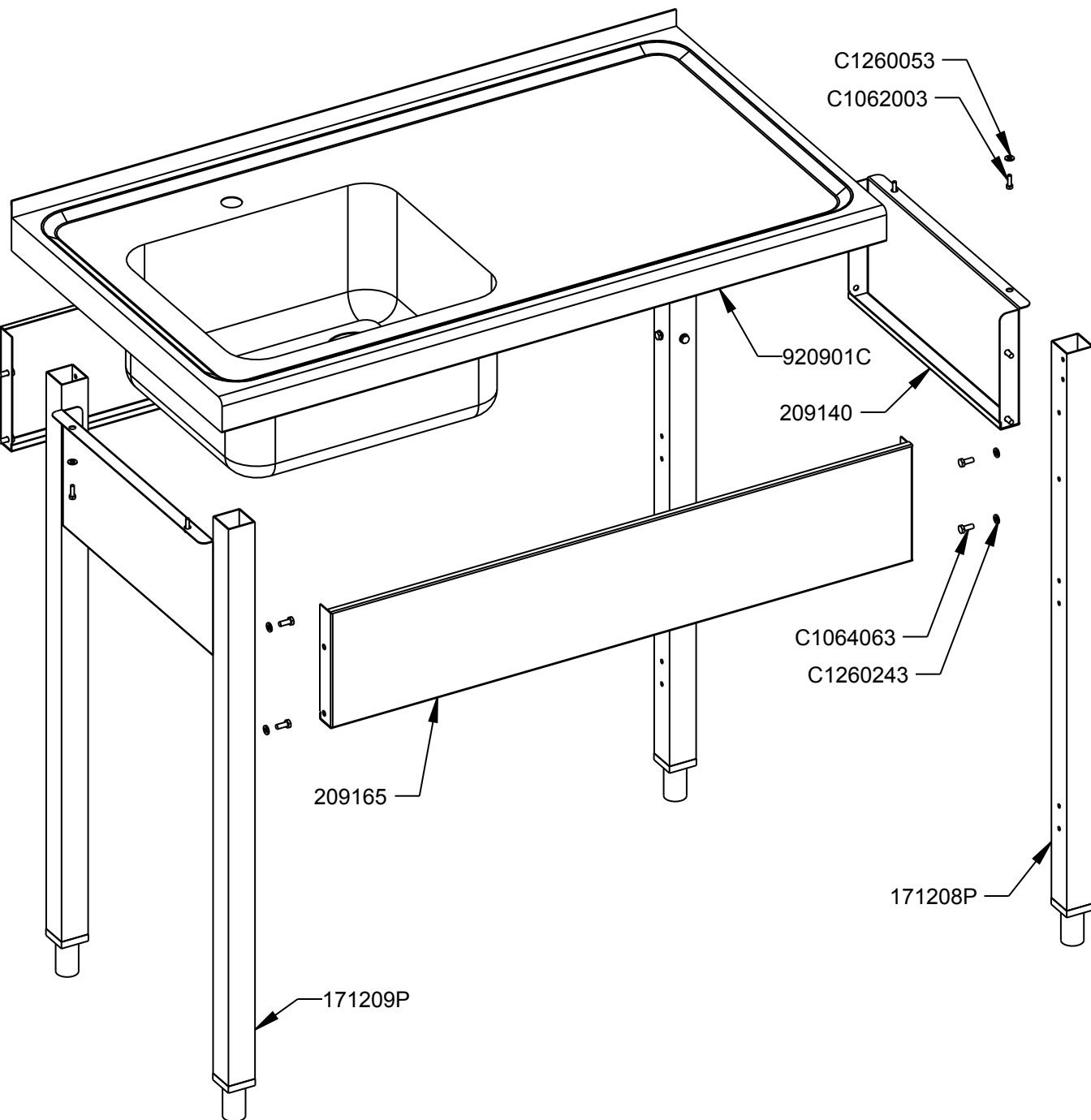

FAMILIA: NEUTRO 2008

FECHA: 30/03/11

MODELO: 209/1

PESO(Kg): 18.009

DENOMINACION:
FREGADERO S/IZQ. 1000x550

ESCALA:
1/8

MATERIAL:
INOX

CODIGO:
2091



Applus®
LGA1
Organismo
Notificado
0370

AENOR
Organismo
Notificado
0099



TOLERANCIAS GENERALES: ± 0.5 mm

QT	COD	DESCRIPCION	FAB.	MATERIAL	DATA	PESO
2	209140	FRISO LATERAL FREGADERO	SÍ	INOFER 1.2	30/03/11	0.936
2	209165	FRISO FREGADERO FRONT/TRASERO	SÍ	INOFER 1.2	30/03/11	1.887
1	209402	OMEGA FREGADERO 1000X550	SÍ	GALVA 1.5	25/03/11	0.805
1	920901C	CONJ.FREGADERO S/IZQ.1000x550	SÍ	INOX	28/03/11	8.548
1	920901	FREGADERO S/IZQ.1000X550	NO	INOX	25/03/11	7.731
2	171208P	PATA DEL.DCHA./TRAS.IZQ.	NO	INOX 40x40x1.5	16/02/11	0.980
2	171209P	PATA DEL.IZQ./TRAS.DCHA.	NO	INOX 40x40x1.5	16/02/11	0.980
4	C1062003	TORNILLO M-5X15 DIN933 ZN	NO	FE ZN	03/02/09	0.003
16	C1064063	TORNILLO M-6X15 DIN933 ZN	NO	FE ZN	17/12/09	0.006
4	C1260053	ARANDELA M-5 DIN-125 ZN	NO	FE ZN	11/05/10	0.001
16	C1260243	ARANDELA M-6 DIN-125 ZN	NO	FE ZN	22/03/11	0.001
6	C1660109	REMACHE EXAG.ROSCADO M-5 S/CAB	NO	Fe ZN	24/03/11	0.002



FAMILIA: NEUTRO 2008

FECHA: 30/03/11

MODELO: 209/1

PESO(Kg): 18.009

DENOMINACION:
FREGADERO S/IZQ. 1000x550

ESCALA:
1/8

MATERIAL:
INOX

CODIGO:
2091



Applus®
LGA1
Organismo
Notificado
0370

AENOR
Organismo
Notificado
0099



TOLERANCIAS GENERALES: ± 0.5 mm

QT	COD	DESCRIPCION
1	920901	FREGADERO S/IZQ.1000X550
1	209402	OMEGA FREGADERO 1000X550
6	C1660109	REMACHE EXAG.ROSCADO M-5 S/CAB

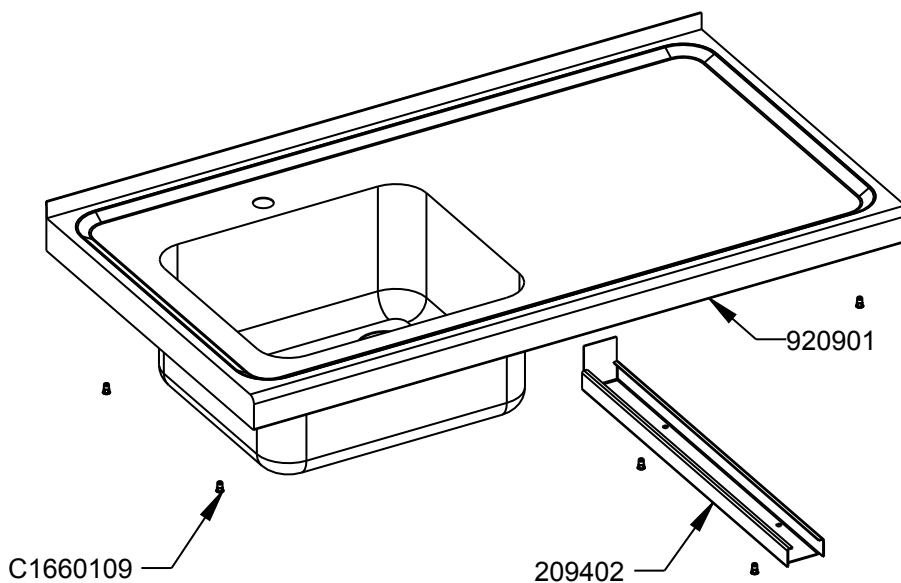
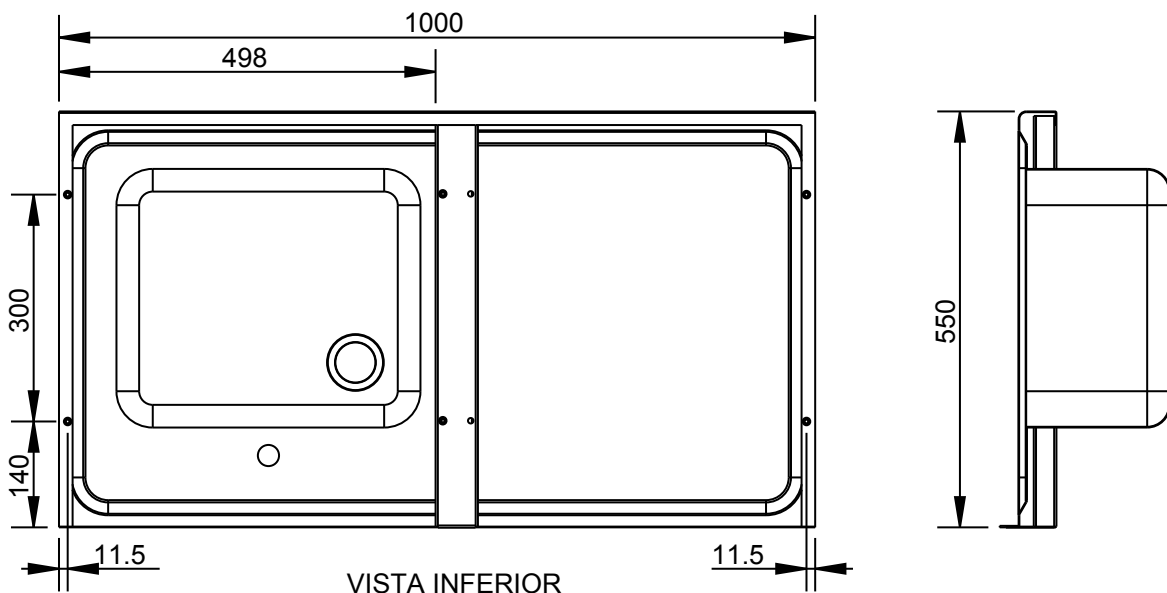
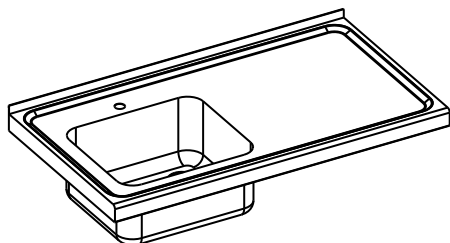

REF.	
O.F.	
QT.	
DEST.	



FAMILIA: NEUTRO 2008

FECHA: 28/03/11

MODELO: 209

PESO(Kg): 8.548

DENOMINACION:
CONJ.FREGADERO S/IZQ.1000x550

ESCALA:
1/10

MATERIAL:
INOX

CODIGO:
920901C