

PARTI DI RICAMBIO  
PIECES DETACHEES  
SPARE PARTS  
ERSATZTEILE  
LISTA DE RECAMBIOS

**C 1000 E BT**  
**C 1300 E BT**

9/02

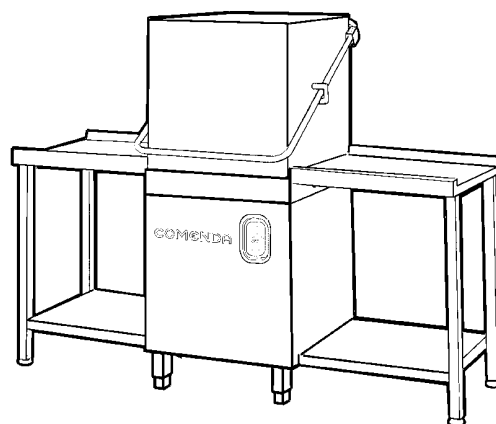

## 2 - Hood/Tank

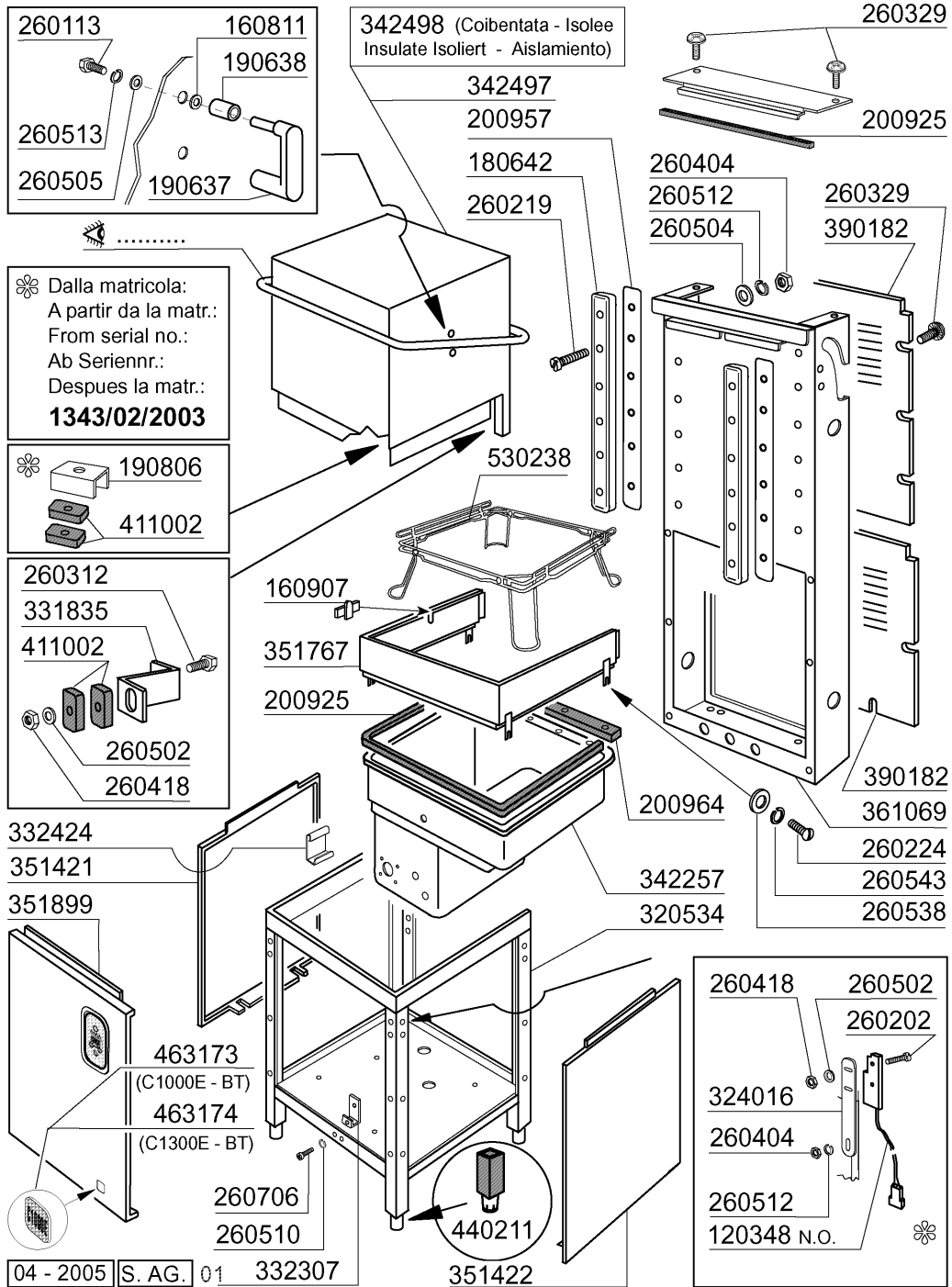

## 2 - Hood/Tank

CODE	DESCRIPTION
120348	MAGN.SWITCH (N.O.)
160811	WASHER F2 18X8.5X1 ALGOF
160907	CONNECTION FOR TABLES C95-155
180642	GUIDE
190637	GUIDE FOR DOOR "C"
190638	ROLLER FOR "C" DOOR GUIDE
190806	MAGNET HOUSING
200925	GASKET
200957	GASKET
200964	GASKET 618X14 SP.2
260113	STAINL.ST.TE SCREW 8X20 A2 UNI
260202	SCREW TCP 3X16
260219	STAINL.ST TCP SCREW 6X35 A2 UN
260224	TB-SCREW 6X15 B23-10-11-12
260312	SCREW TSP 4X16
260329	VITE M5X12 SPEC.ZIGR.SOTTOTEST
260404	STAINLESS STEEL NUTS D6 UNI 55
260418	SELF-LOCKING NUT M4
260502	S/S FLAT WASHER D.4
260504	ST/ST FLAT WASHER D6
260505	STAINL.STEEL FLAT WASHER D8
260510	GROWER WASHER D.4
260512	ST/ST GROWER WASHER D6
260513	GROWER WASHER D8
260538	WASHER 18X6X1,5 ST/ST
260543	WASHER D.6 ST/ST
260706	SCREW 3,9X13 S/S
320534	LOWER FRAME
324016	SWITCH BRACKET
331835	BRACKET F.MAGNET C165
332307	BRACKET
332424	SQUADRETTA SOST.TUBO PRESS.C
342257	TANK
342497	HOOD
342498	INSULATED HOOD
351421	LEFT PANEL
351422	RIGHT PANEL
351767	FRONT PANEL
351899	FRONT PANEL C1000-1300
361069	BACK FRAME
390182	BACK PANEL
411002	PERMANENT MAGNET 24X12
440211	LEGS
463173	DOX SYSTEM C1000E
463174	DOX SYSTEM C1300E
530238	RACK SUPPORT C-SERIES

### 3 - Tank

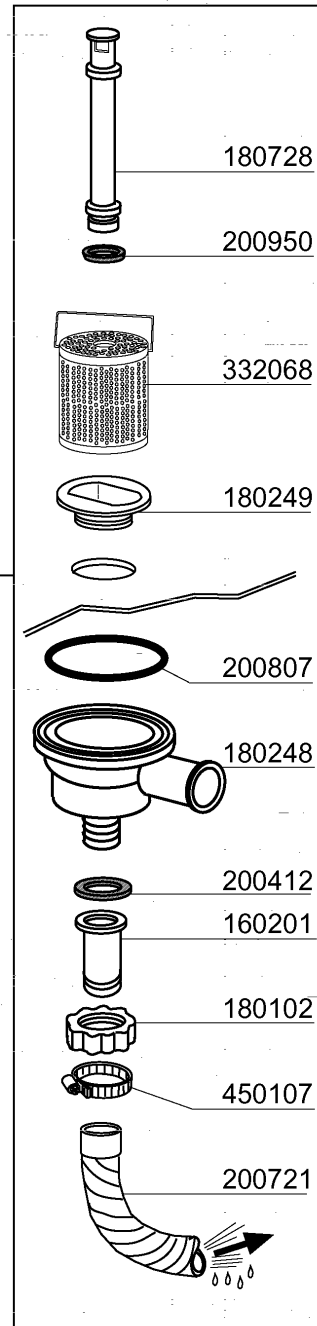
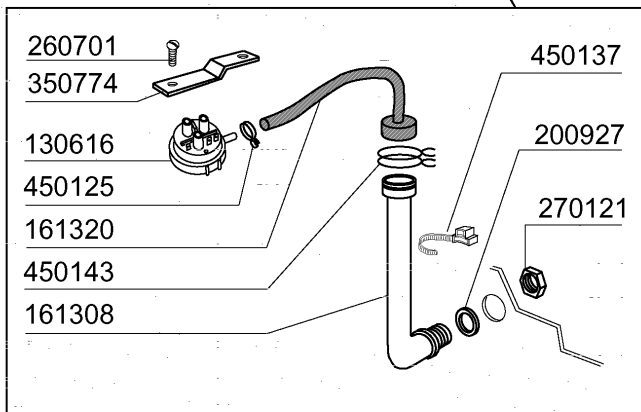
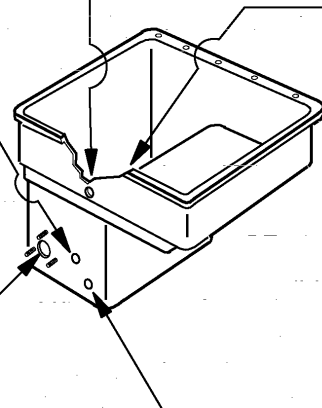
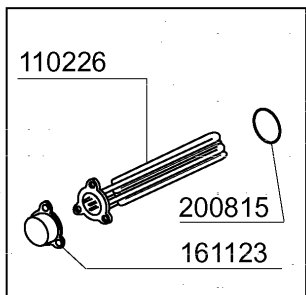
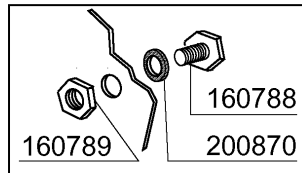
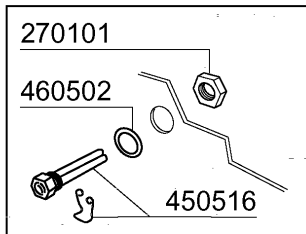
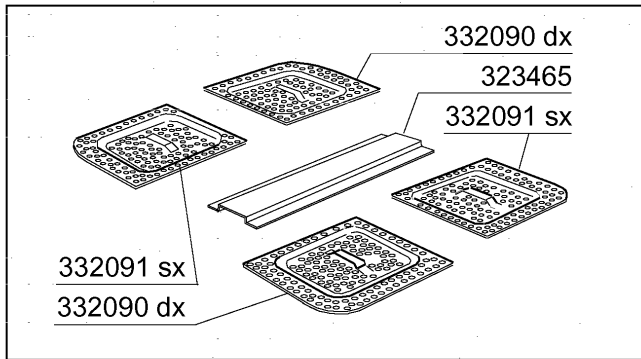

02 - 2004 | S. AG.

### 3 - Tank

CODE	DESCRIPTION
110226	HEAT. ELEMENT 3000W 230/400V
130616	PRESSURE SWITCH 190/80 FOR C95
160201	ELBOW F.TANK INLET MOPLN
160788	PLUG
160789	NUT
161123	HEAT.ELEMENT COVER H42 SNL
161308	AIR CHAMBER C95-155
161320	HOSE FOR AIR CHAMBER
180102	DRAIN PIPE NUT 1"1/2 F45-55
180248	SUCTION TANK
180249	NUT
180728	OVERFLOW PIPE
200412	GASKET DRAIN 11/2" 45X33X3
200721	DRAIN HOSE 28X35 2MT.
200807	O-RING 3,53 X 110,72
200815	O-RING F. HEAT.ELEM.
200870	GASKET 18X10X2
200927	GASKET FOR AIR TRAP
200950	VITON GASKET
260701	SCREW 3,5X9,5
270101	HEXAGON LOCK NUT 1/2"
270121	NUT FOR AIR TRAP
323465	STRAINERS SUPPORT
332068	STRAINER
332090	RIGHT STRAINER
332091	TANK LEFT STRAINER
350774	BRACKET
450107	CLAMP FE ZN 38-50 H=12,2
450125	ELASTIC CLAMP D. 10,4X9,8
450137	COLLAR CONNECTION WITH BASE 31
450143	CLAMP D.39,7 X 37,7
450516	THERMOSTAT SHIELD FOR 2 TERMOS
460502	GASKET 30X21X2

## 4 - Handle

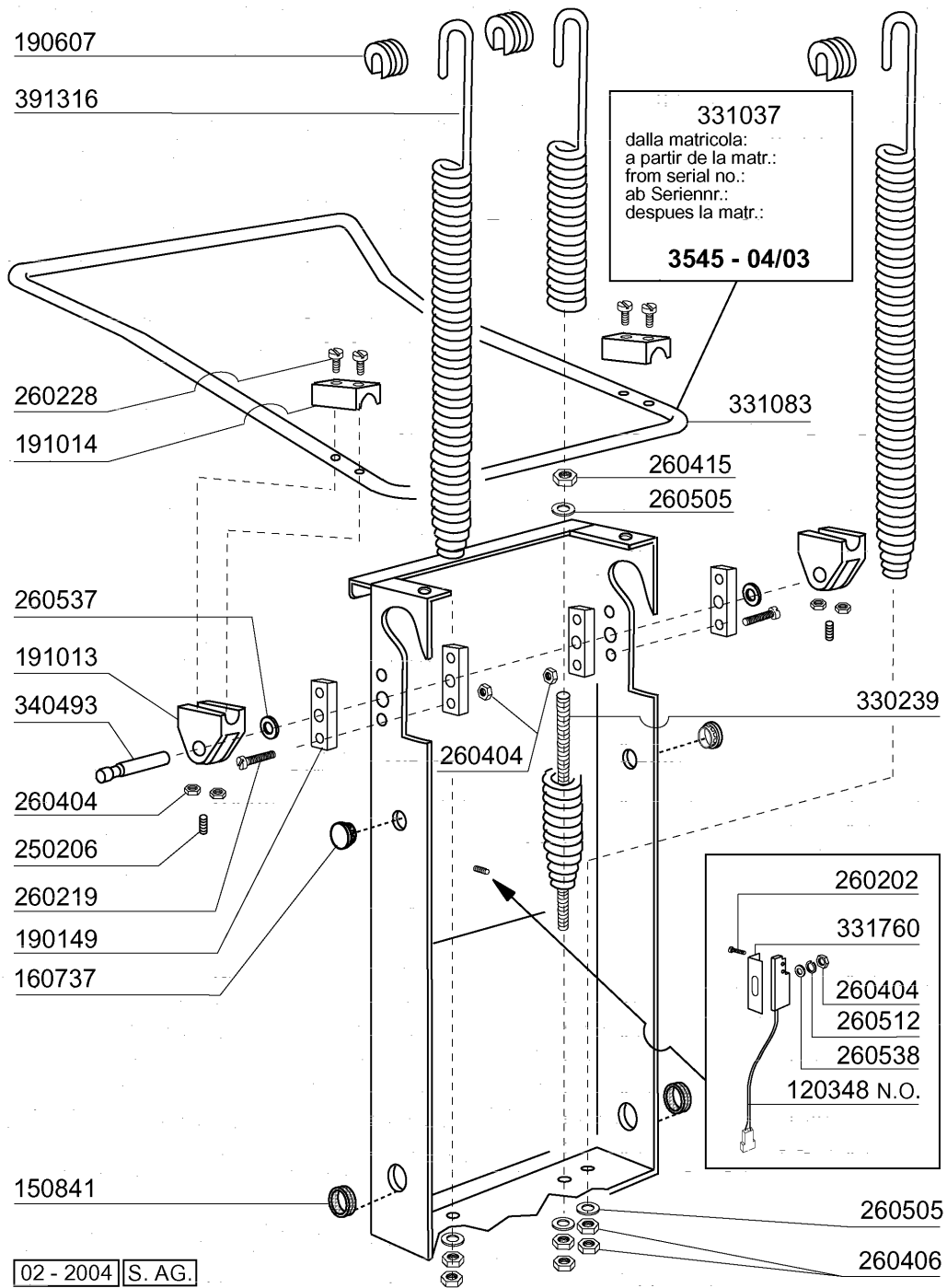

#### 4 - Handle

CODE	DESCRIPTION
120348	MAGN.SWITCH (N.O.)
150841	CABLE HOLDER
160737	PLUG HEYCO D.34,9
190149	REINFORCEMENT FOR HANDLE SUPP.
190607	HANDLE BUSH C30-70
191013	HINGE F. SUPPORT C30-C70
191014	FLANGE F. HANDLE C30-70
250206	GRUB SCREW D.6
260202	SCREW TCP 3X16
260219	STAINL.ST TCP SCREW 6X35 A2 UN
260228	STAINL.ST SPECIAL SCREW 6X42 3
260404	STAINLESS STEEL NUTS D6 UNI 55
260406	NUT 8MA
260415	STAINLESS STEEL SELF-LOCKING N
260505	STAINL.STEEL FLAT WASHER D8
260512	ST/ST GROWER WASHER D6
260537	STAINL.STEEL FLAT WASHER D13X2
260538	WASHER 18X6X1,5 ST/ST
330239	ROD
331037	HANDLE C95-155-165 ISOLATED
331083	HANDLE
331760	BRACKET
340493	PIN F. HINGE C30
391316	SPRING FOR HANDLE C85/140-G75

### 5 - Wash/Rinse column

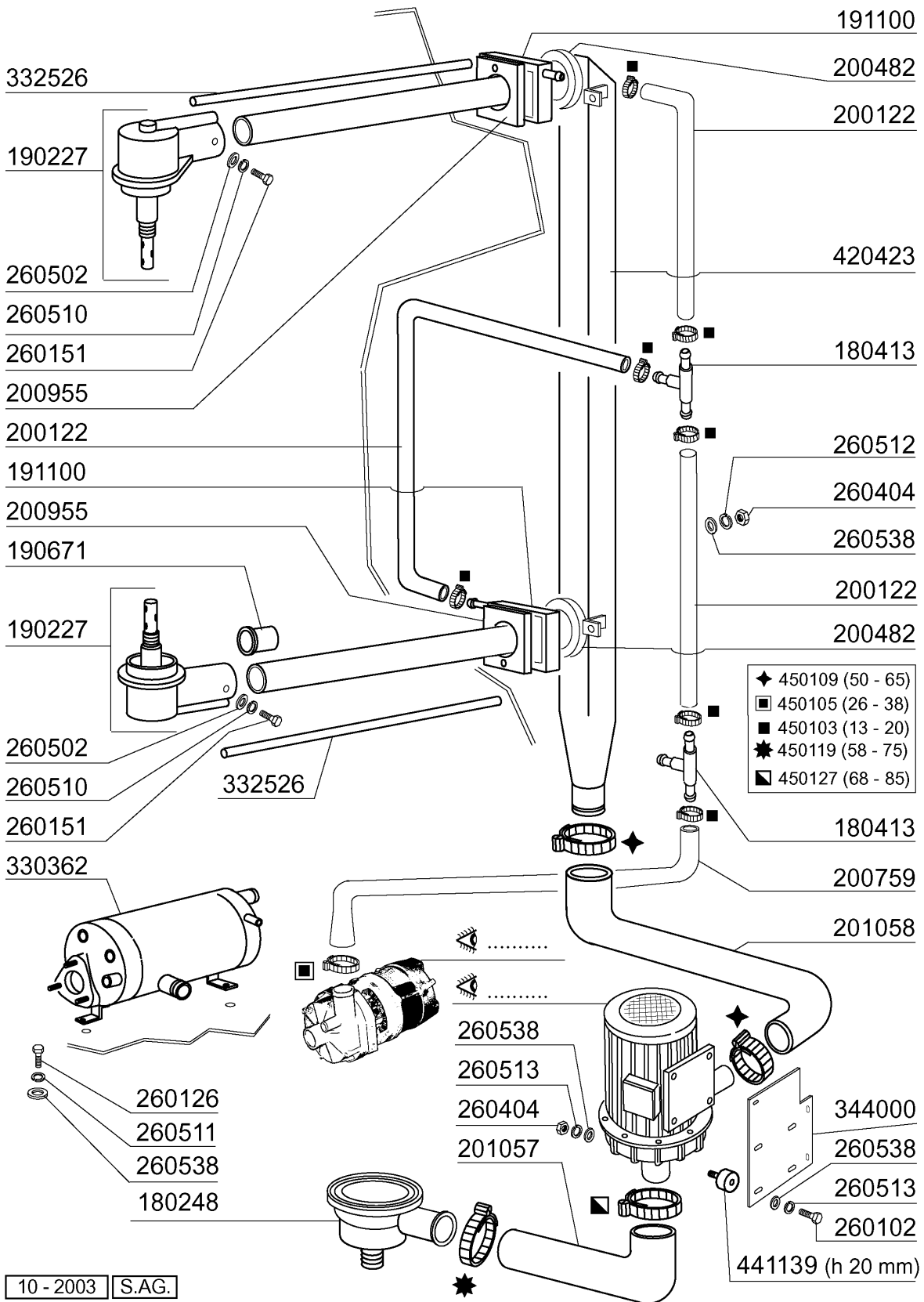

10 - 2003 S.A.G.

## 5 - Wash/Rinse column

CODE	DESCRIPTION
180248	SUCTION TANK
180413	TEE NIPPLE D.11,5 - RINSE ASSE
190227	ARM SUPPORT
190671	BUSH
191100	RINSE COLLECTOR C-LC
200122	HOSE 11X19
200482	GASKET 60X54 RAMP C140
200759	DELIVERY HOSE FOR ECORINSE AC-
200955	GASKET
201057	WASH PUMP INLET HOSE
201058	OUTLET HOSE
260102	SCREW TE 6X10
260126	SCREW TE 5X12
260151	SCREW TE 4X12
260404	STAINLESS STEEL NUTS D6 UNI 55
260502	S/S FLAT WASHER D.4
260510	GROWER WASHER D.4
260511	GROWER WASHER D.5
260512	ST/ST GROWER WASHER D6
260513	GROWER WASHER D8
260538	WASHER 18X6X1,5 ST/ST
330362	BOOSTER FOR BREAK TANK
332526	RINSE HOSE
344000	PUMP SUPPORT
420423	WASH RAMP C/LC
441139	VIBRATION-DAMPING FEET 25X20X6
450103	CLAMP FE ZN. 13-20 H=9
450105	CLAMP FE ZN. 26-38 H=12,2
450109	CLAMP 50-65
450119	CLAMP FE ZN. 58-75 H=12,2
450127	CLAMP FE ZN. 68-85 H=12,2

6 - Wash arm

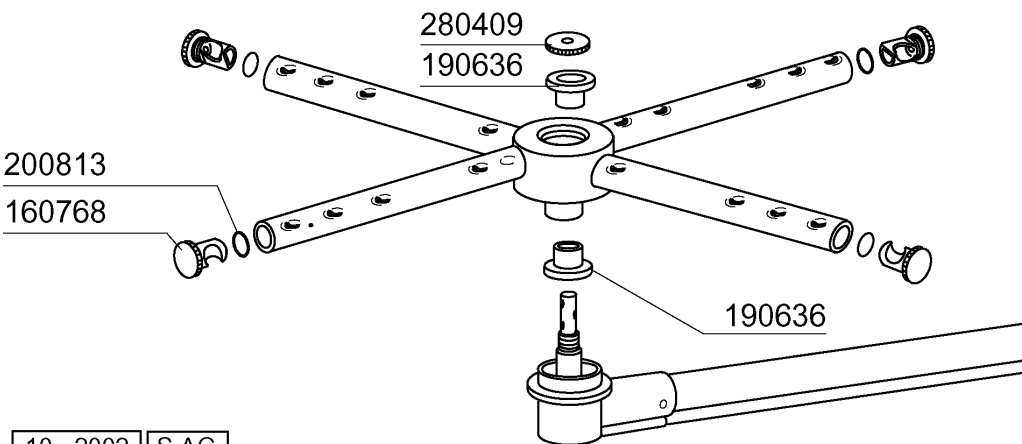
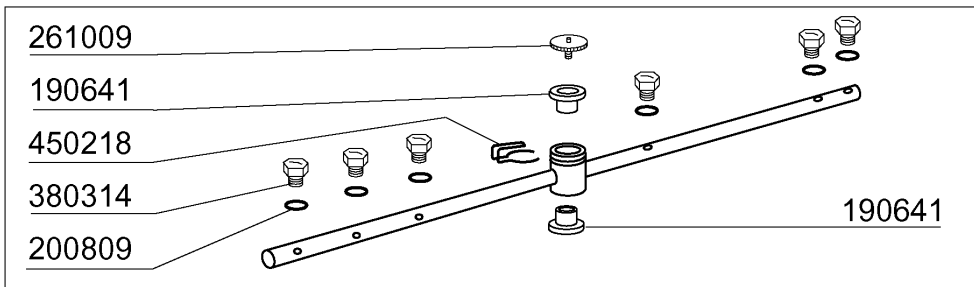
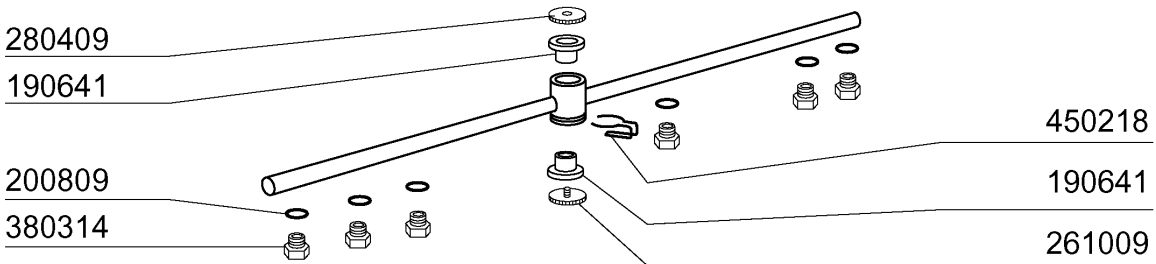
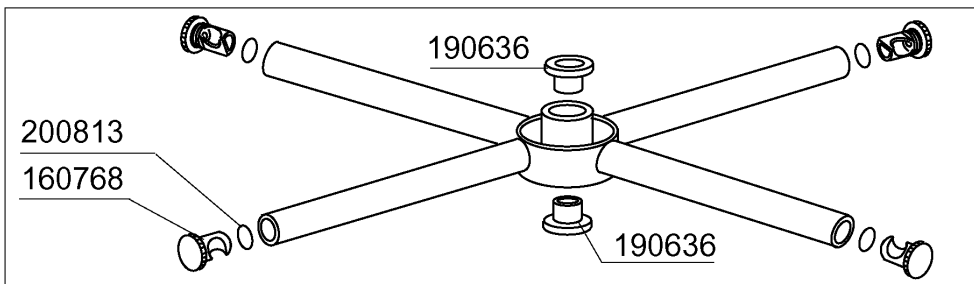
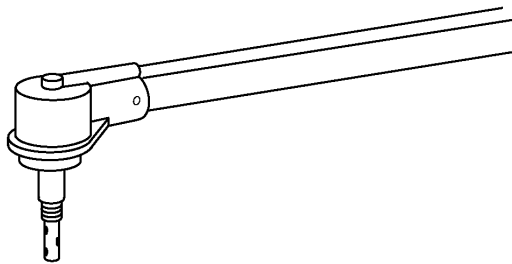

10 - 2002 S.A.G.

## 6 - Wash arm

CODE	DESCRIPTION
160768	PLUG FOR "C95-155" WASH ARM
190636	BUSH FOR C95-155-165 WASH ARM
190641	BUSH FOR C95-155-165 RINSE ARM
200809	OR GASKET 1,78X8,73X12,29
200813	OR GASKET 2,21X16,36X20,78
261009	RETAIN.SCREW FOR WASH-RINSE AR
280409	RETAIN.LOCK NUT CENTR.CROSS C1
380314	RINSE JETS 801/HR
420535	WASH ARM C1300-C155
430316	RINSE ARM FOR C95-C155-C165
450218	SPRING F.RINSE ARM RETAIN.SCRE

### 7 - Rinse Assembly / Break Tank

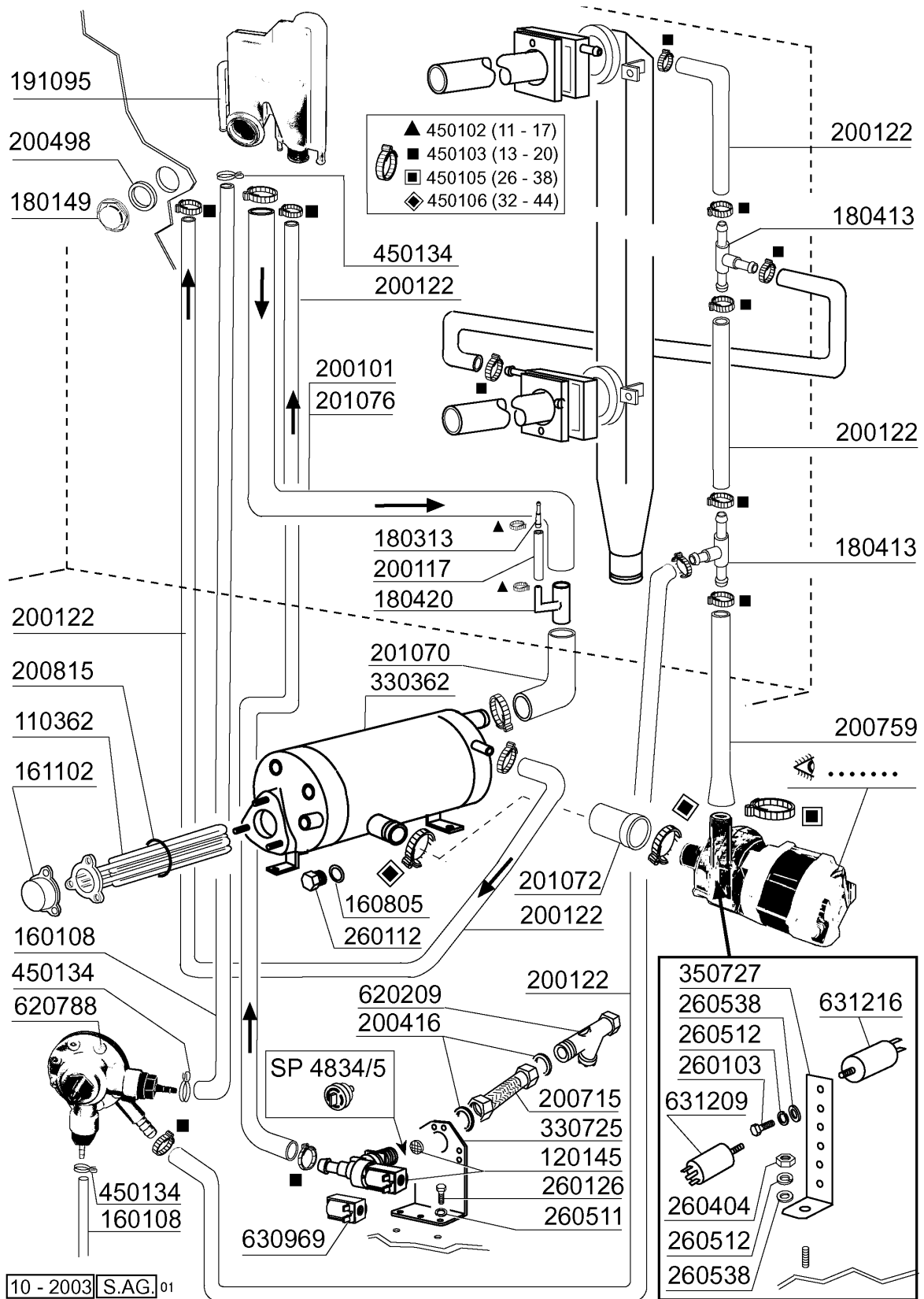

## 7 - Rinse Assembly / Break Tank

CODE	DESCRIPTION
110362	HEAT.ELEMENT 9000W 220/380V
120145	SOLENOID VALVE 12 LT 1 WAY
160108	INJECT.INLET HOSE D.8X5
160805	GASKET D.8
161102	ELEMENT COVER MOPL.
180149	PLASTIC NUT
180313	TEE-NIPPLE
180413	TEE NIPPLE D.11,5 - RINSE ASSE
180420	TEE-NIPPLE
191095	CONTAINER FOR BREAK TANK
200101	RUBBER TUBE 25X35
200117	RUBBER HOSE 7X16
200122	HOSE 11X19
200416	GASKET D. 3/4"
200498	GASKET
200715	HOSE WATER INLET 2M STAINL.ST
200759	DELIVERY HOSE FOR ECORINSE AC-
200815	O-RING F. HEAT.ELEM.
201070	HOSE
201072	HOSE
201076	HOSE
260103	SCREW TE 6X12
260112	STAINLESS STEEL TE-SCREW 8X16
260126	SCREW TE 5X12
260404	STAINLESS STEEL NUTS D6 UNI 55
260511	GROWER WASHER D.5
260512	ST/ST GROWER WASHER D6
260538	WASHER 18X6X1,5 ST/ST
330362	BOOSTER FOR BREAK TANK
330725	STANDARD BRACKET F.SOLEN.VALV
350727	BRACKET
450102	CLAMP FE ZN 11-17 H=9
450103	CLAMP FE ZN. 13-20 H=9
450105	CLAMP FE ZN. 26-38 H=12,2
450106	CLAMP FE ZN 32-44 H=12,2
450134	ELASTIC HOSE CLIP D.9,3/8,8
620209	INLET WATER FILTER
620788	RINSE AID INJECTOR H21428
630969	COIL S4216 220/50HZ
631209	ANTI-NOISE FILTER
631216	CAPACITOR 6.3 MF 450V

8 - Wash pump

**C1000 E BT**

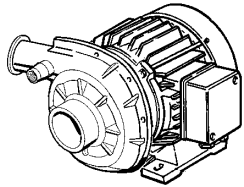

HP 1,5 - Kw 1.1  
V. 230 - 400/3 50 Hz  
(ZF 650 DX - 1612)

**100798**

**100796**

HP 2 - Kw 1.5  
V. 230 - 400/3 50 Hz  
(ZF 800 DX - 1611)

**C1300 E BT**

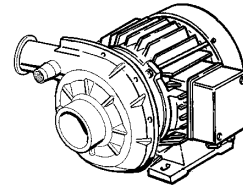

631692 (50 Hz) Ø 120 mm  
631699 (60 Hz) .....

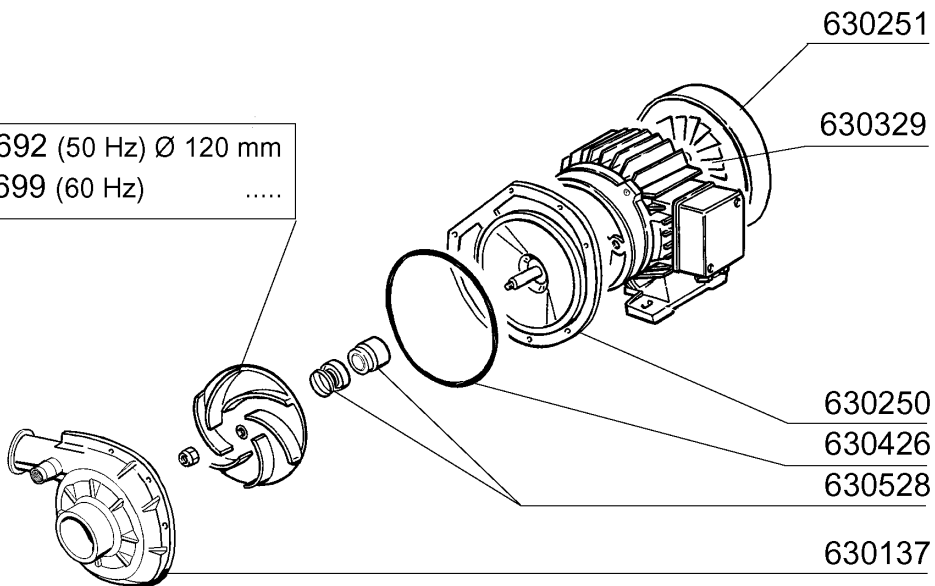

630533  
631698  
630427  
630136

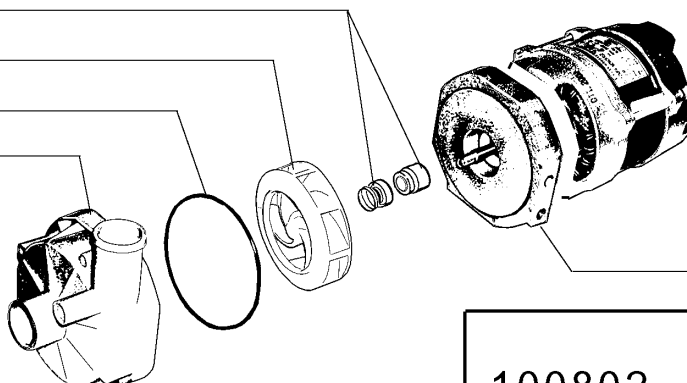

631216  
6,3 µF

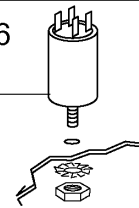

630249

**100802**

230V  
50 Hz - HP 1  
kW 0,2 (ZF131 DX)

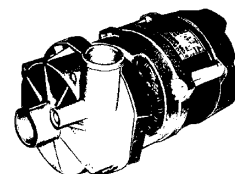

10 - 2003 | S. AG.

## 8 - Wash pump

CODE	DESCRIPTION
100796	PUMP 2HP 400/3/50HZ LGB
100798	PUMP 1,5HP LGB
100802	PUMP HP 0,3 230V-50HZ
630136	PUMP VOLUTE LGB ZF131DX
630137	PUMP VOLUTE LGB ZF800DX
630249	PUMP FLANGE ZF131 DX
630250	BACK PLATE PUMP ZF650/800
630251	FAN HOUSING ZF650/800
630329	PUMP FAN IMPELLOR ZF650/800
630426	GASKET LGB ZF800
630427	O-RING FOR PUMP ZF131DX
630528	SEAL LGB ZF800 2HP
630533	PUMP SEALS WASH PUMP ZF131DX
631216	CAPACITOR 6.3 MF 450V
631692	IMPELLER PUMP ZF650/800
631698	PUMP IMPELLER ZF131DX
631699	PUMP IMPELLER 60HZ ZF650/800

### 9 - Control panel

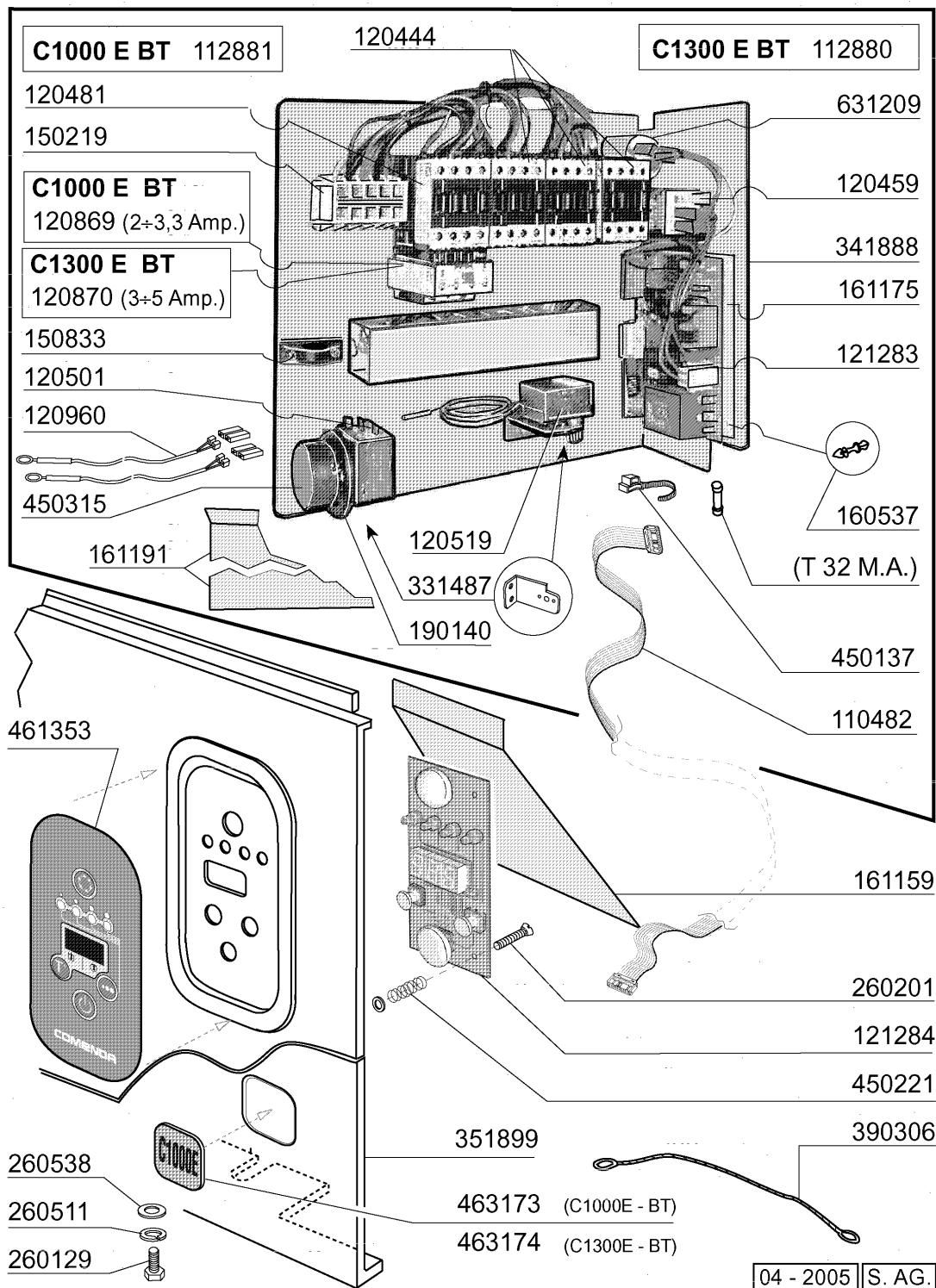

## 9 - Control panel

CODE	DESCRIPTION
110482	CABLE FOR PCB FC-C-GE
112880	WIRING C1300E BT
112881	WIRING C1000E BT
120444	CONTACTOR 9A 220V 50HZ
120459	AUXIL.RELE 16A 220V
120481	CONTACTOR 9A-230V 50/60HZ
120501	THERMOSTAT 30/90ØC
120519	SECURITY THERMOSTAT 95-125Ø
120869	OVERLOAD RELAY 2/3,3
120870	OVERLOAD RELAY 3/5
120960	PROBE C-G
121283	ELECTRONIC PANEL "C-GE"
121284	ELECTRONIC CONTROL PANEL C-GE
150219	TERMINAL BLOCK 5P MMQ165VD26
150833	CABLE HOLDER BC/BR
160537	ELECTRONIC CARD SPACER
161159	PROTECT. COMMANDS SWITCHBOARD
161175	PROTECTION
161191	CONTROL BOX COVER
190140	BUTTON HOLDER BR-BC-FC
260129	SCREW TE M 5X20
260201	SCREW TCP 3X10
260511	GROWER WASHER D.5
260538	WASHER 18X6X1,5 ST/ST
331487	BRACKET FOR 1 THERMOSTAT
341888	CONTROL BOX SUPPORT
351899	FRONT PANEL C1000-1300
390306	CABLE
450137	COLLAR CONNECTION WITH BASE 31
450221	SPRING FOR ELECTRONIC TIMER
450315	KNOB F. THERMOSTAT 90Ø
461353	PLATE C-GE ELECTRONIC
463173	DOX SYSTEM C1000E
463174	DOX SYSTEM C1300E
631209	ANTI-NOISE FILTER

# 10 - Rinse aid injector

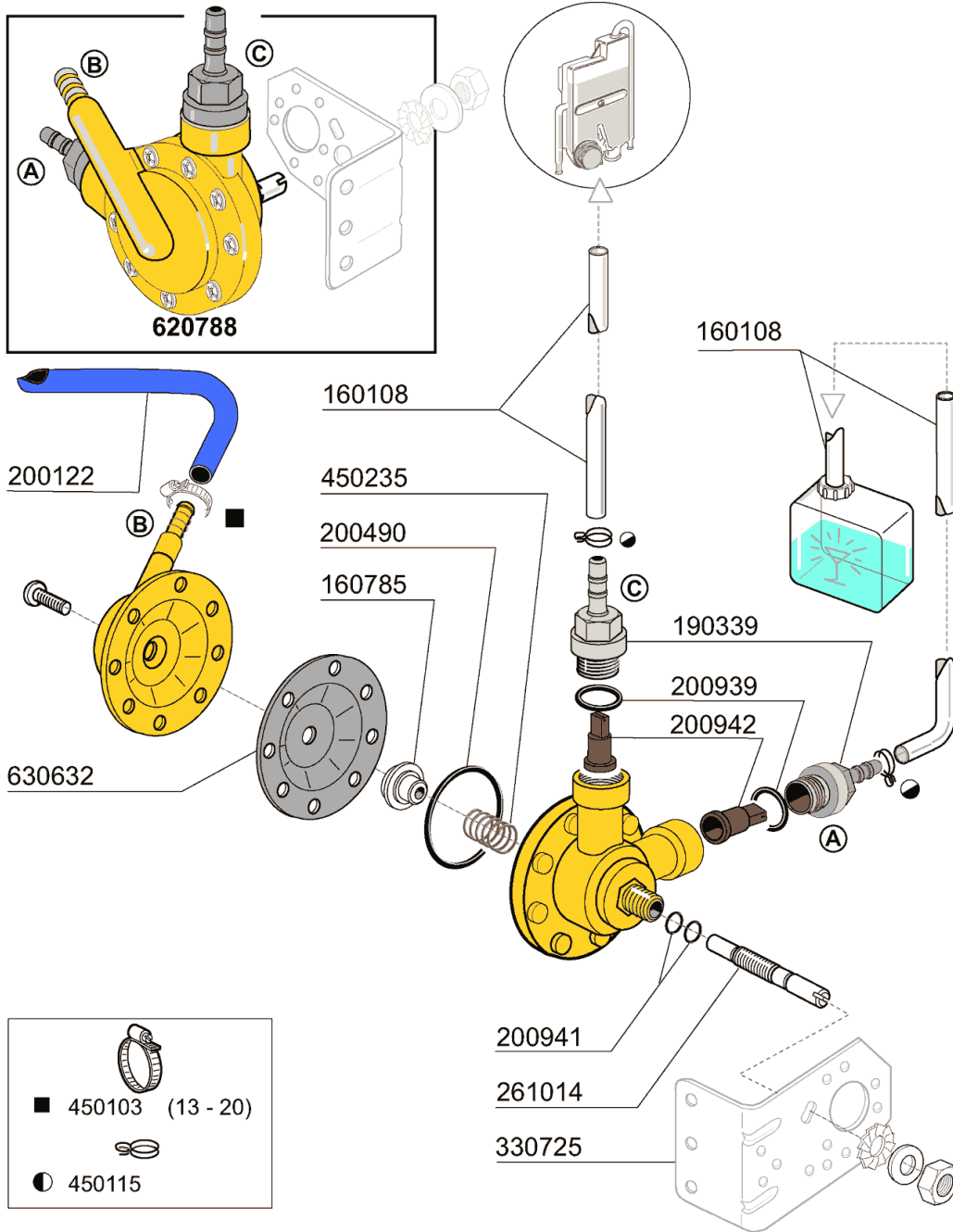

04 - 2007 | S. AG.

NEW  
2006

## 10 - Rinse aid injector

CODE	DESCRIPTION
160108	INJECT.INLET HOSE D.8X5
160785	GUIDE FOR SPRING RINSE AID INJ
190339	RINSE AID INJECTOR CONNECTION
200122	HOSE 11X19
200490	PROTECTION GASKET MOD.ADV.
200939	OR GASKET
200941	OR GASKET
200942	VALVE RINSE INJECTOR HVD
261014	SCREW
330725	STANDARD BRACKET F.SOLEN.VALV
450103	CLAMP FE ZN. 13-20 H=9
450115	ELASTIC CLAMP D.8,3/7,8
450235	SPRING RINSE AID INJECTOR
620788	RINSE AID INJECTOR H21428
630632	DIAPHRAGM RINSE INJECTOR HVD

# 11 - CRC

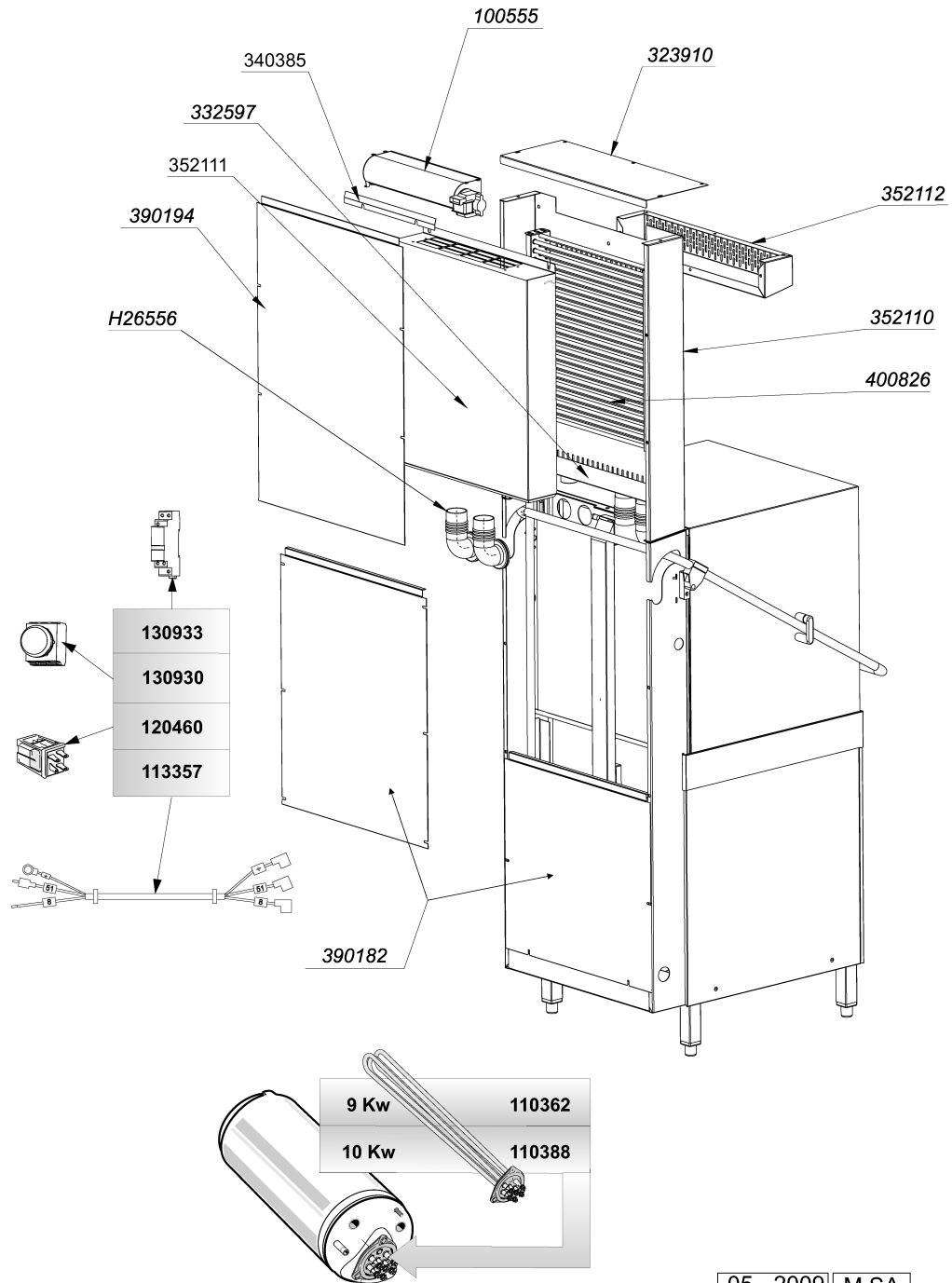

05 - 2009 M.SA

## 11 - CRC

CODE	DESCRIPTION
100555	FAN TGA60/1 360-30
110362	HEAT.ELEMENT 9000W 220/380V
110388	HEAT.ELEMENT 10000W 230/400V
113357	CABLE FOR CRC
120460	RELAY 16A 220V
130930	CONTACT ABB 1NO/1NC 180"
130933	SUPPL. CONTACT NO/NC ABB
323910	CRC UPPER COVER
332597	COLLETTORE ASPIRAZ. CRC C2001
340385	PARATIA VENT."POST" CRC C2001
352110	BACK PANEL
352111	BACK PANEL CRC
352112	FRONT COVER CRC
390182	BACK PANEL
390194	BACK PANEL CRC
400826	CRC BATTERY
H26556	HOSE