

	*	**
G30-28+30mbar G31- 37mbar	533020800	533057700
G30- 50mbar	533020800	533057600
G20- 20mbar G25- 25mbar	533020300	533047500
G20- 20mbar DE-AT	533020300	533047500
G25- 20mbar	533020300	533046900
G25- 25mbar NL	533020300	533046800
G20- 25mbar	533020300	533047400

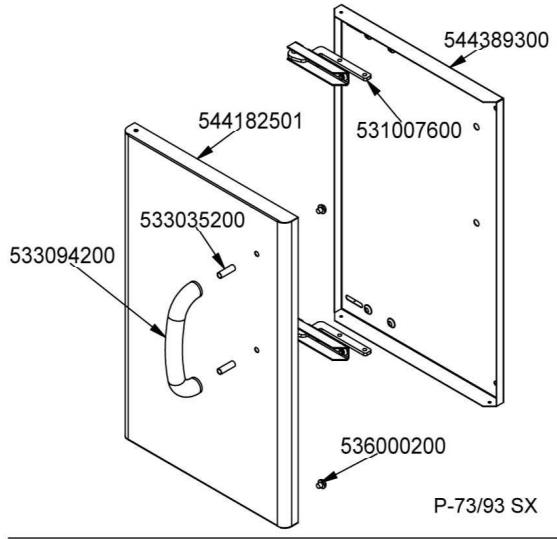

P-73/93 SX

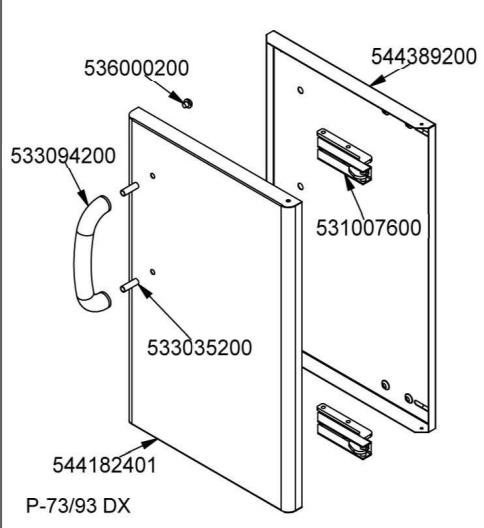

P-73/93 DX

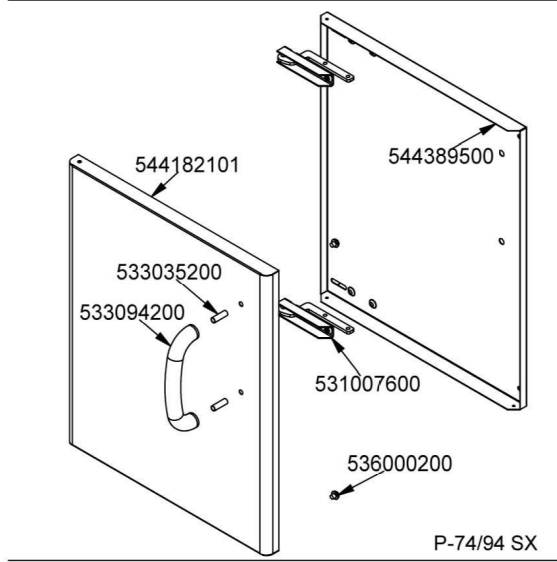

P-74/94 SX

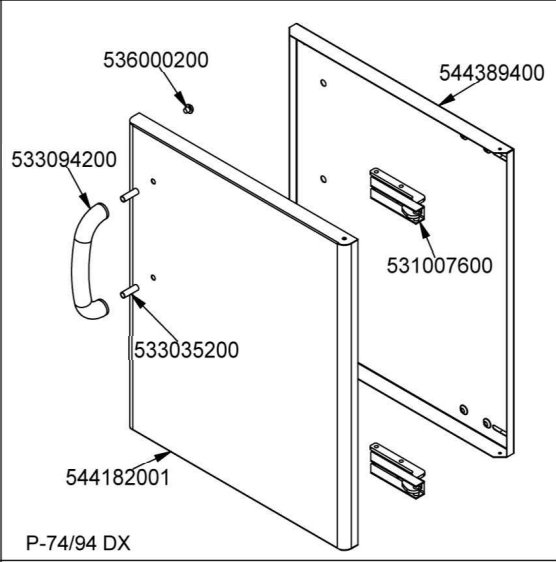

P-74/94 DX

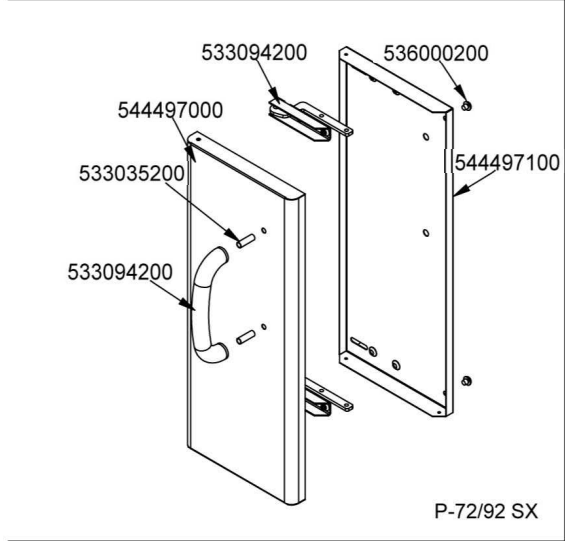

P-72/92 SX

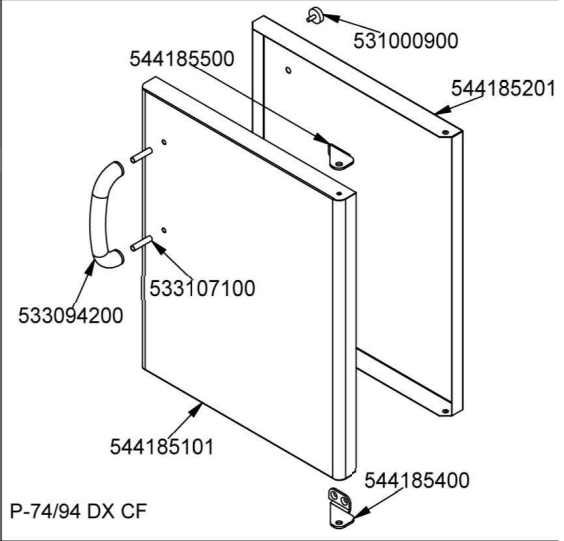

P-74/94 DX CF

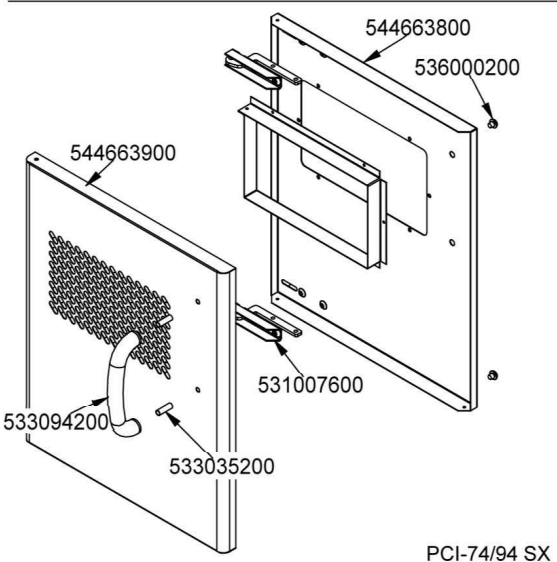

PCI-74/94 SX

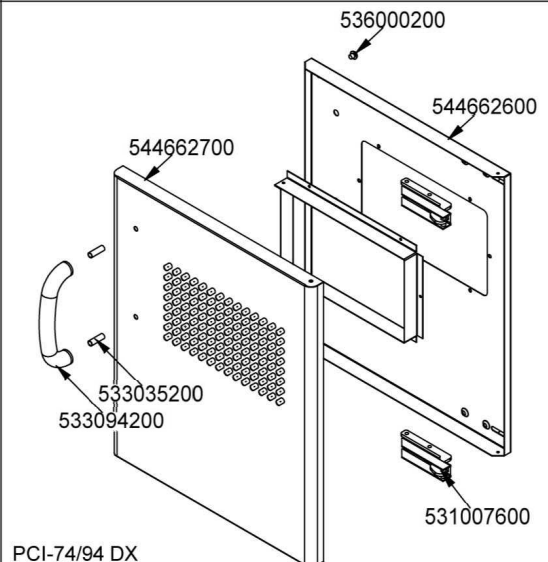

PCI-74/94 DX

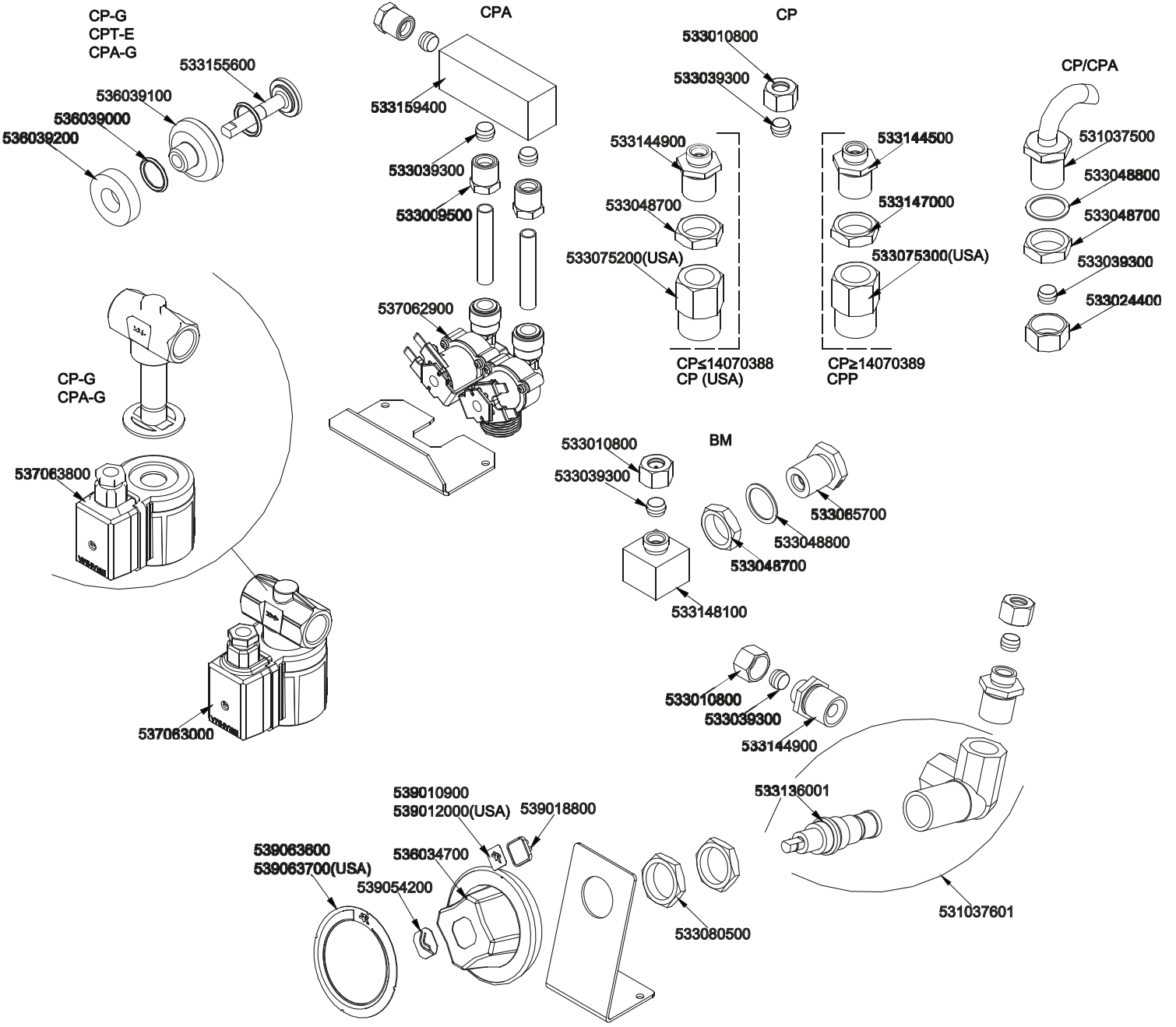

BR BRM-G

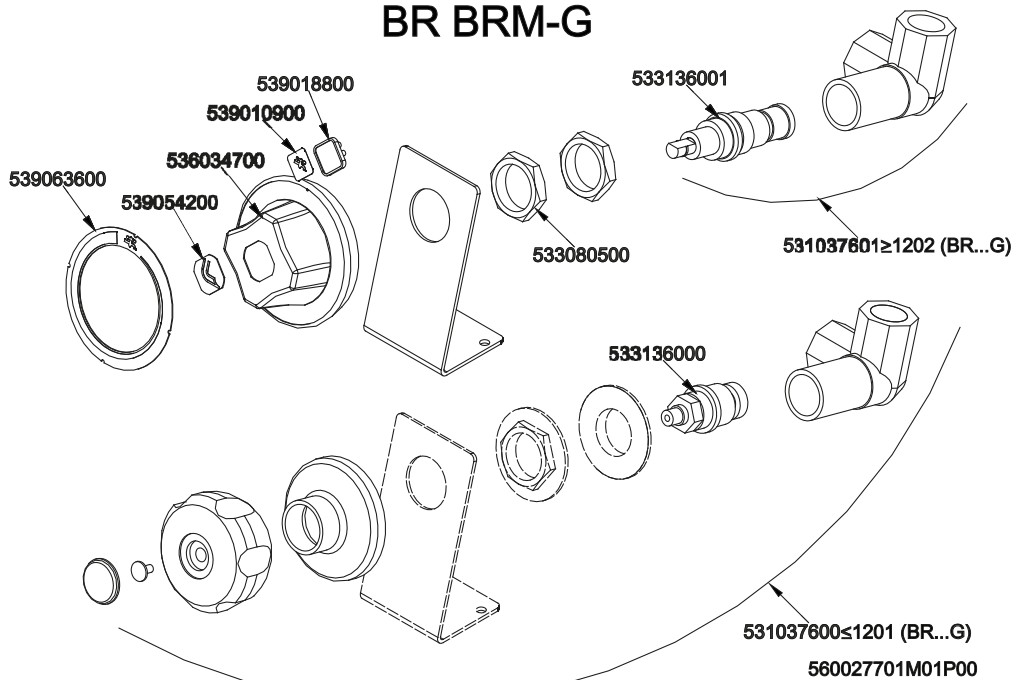

Page	Pos	Code	Description
001		532004100	FLUE GRID L=370 90LINE (RAF
001		541136900	LOW SPACER 76 1 GRID
001		531064800	GRID FOR BASKET SUPPORT * CP-66
001		544503800	SUPP.CESTO SCOLO CP-76
001		541157802	UPPER PLATE CP-76G
001		531042800	SEMISPHERE FILTER
001		546006100	RUBBER TUBE §25INT.*§33EXT.*L=540
001		544173500	LEFT SIDE PANEL S.70
001		541142700	BURNER SUPPORT FT-76G CP-76G
001		531056300	BURNER TUB.07 KW CP-76G S70
001		541140701	CONTROL PANEL S607090 CP-76G
001		533039900	PIPE HOLDER 1" G M D.24
001		531018600	BALL VALVE 1"G M-F CPM-62G
001		533040000	1"G F-F-F "T" FITTING
001		533038200	1" G M-F ELBOW FITTING
001		544173400	RIGHT SIDE PANEL S.70
001		536005200	INOX LEG 2" 120-180 M10
002		533069600	BY PASS COCK §130 20S-21S
002		533010800	TUBE NUT D.10 M16*1,5
002		533039300	BICONE §10
002		533039100	BICONE §6
002		533018500	FITTING FOR BICONE D.6 M10*1
002		536034500	KNOB §77 4P. §08*6,5
002		539054200	STAMP Ø20,5 CR."L" LOTUS R.
002		539062800	RED STICKING DISK 72
002		539018900	INDEX FOR KNOB W/RED SIGN
002		531025500	GAS COCK 21S P.V.BY-PASS Ø130
002		533009500	NIPPLE FOR BICONE 10S
002		533009400	BICONE 10S
002		537002800	PIEZOELECTRIC IGNITION M18 WITH NUT
003		544389300	CONTROP.73 SX APP. LT
003		531007600	DOOR HINGE
003		544182501	LEFT DOOR 73
003		533094200	S/S HANDLE FOR 70/90 SERIES
003		533035200	HANDLE SPACER
003		536000200	D.12 H.4 BUMPER
003		544389200	CONTROP.73 DX APP. LT
003		544182401	RIGHT DOOR 73
003		544182101	LEFT DOOR 74
003		544389500	INNER-DOOR OF LHD 74
003		544389400	CONTROP.74 DX APP. LT
003		544182001	RIGHT DOOR 74
003		544497000	PORTA 72 SX
003		544497100	CONTROP.72 SX APP. LT
003		544185101	RIGHT DOOR 74 CF
003		533107100	HANDLE SPACER OF CF-70
003		544185500	UPPER DOOR HINGE FOR COMPARTME CF70
003		531000900	MAGNET §22 KG.3 WITH DISK
003		544185201	INNER DOOR * 74DX
003		544185400	LOWER DOOR HINGE FOR COMPARTME CF70
003		544663900	LHD 74 DOOR FOR PCI

Page	Pos	Code	Description
003		544663800	74 LHD OVEN INNER DOOR FOUR PCI
003		544662700	DOOR 74 DX PCI
003		544662600	CONTROP.74 DX APP. LT PCI
004		533010800	TUBE NUT D.10 M16*1,5
004		533155600	PERNO PER SENSORE ACQUA
004		536039100	GUIDA PER SENSORE ACQUA
004		536039000	GUARNIZ.O-RING 12,42X1,78 SILIC.
004		536039200	DISTANZIALE PER SENSORE ACQUA
004		533039300	BICONE §10
004		533159400	RACC.UN.2 U.ELETTROV.ACQUA CP
004		533144500	FITTING FOR WATER INPUT 3/4G
004		531037500	RACCORD CA.H2O 1/2G CAN.D10
004		533144900	MALE FITTING WATER INLET M16X1,5
004		533048700	NUT 1/2G ZN
004		533048800	GASKET §30*§21*2 FIBRE
004		533147000	BICONE FITTING 3/4G ZN
004		533009500	NIPPLE FOR BICONE 10S
004		533024400	HEXAGONAL NUT 1/2G TUBE D.10
004		537062900	ELETTROV.A.3/4GM-2Ø10JG 230V RPV
004		537063800	COIL ELECTROV.G.1/2GF 230V
004		533065700	FITTING FOR WATER INPUT 1/2G
004		533148100	RACC.A GOM.90° 1/2G F.M16X1,5M. (S
004		537063000	ELETTROV.G.1/2GF-1/2GF 230V
004		539010900	ADHESIVE LABEL FOR DRAIN COCK
004		533136001	SCREW TAP WATER LOAD FOR CP S70/90
004		539012000	ADHESIVE LABEL FOR DRAIN COCK USA
004		539018800	BLANK INDEX FOR KNOB
004		539063600	ADHESIVE DISK 72 FOR DRAIN COCK
004		539063700	ADHESIVE DISK 72 FOR DRAIN COCK USA
004		536034700	KNOB §77 4P. §08*6,5 F§30
004		539054200	STAMP Ø20,5 CR."L" LOTUS R.
004		531037601	TAP FOR WATER 90°DX CP
004		533136000	SCREW TAP WATER LOAD FOR CP S70/90
004		531037600	TAP FOR WATER LOADING 1/2"GF CP 90