



VM 900

LIST OF THE EXPLODED VIEWS

SHELL ASSY

COOLING SYSTEM

HYDRAULIC CIRCUIT

SPRAYER PUMP

ELECTRIC PARTS

2nd Version

From s/n.141196 up Today

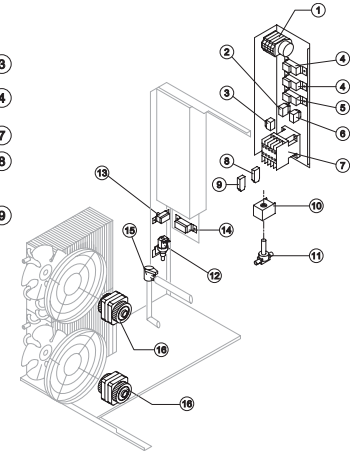
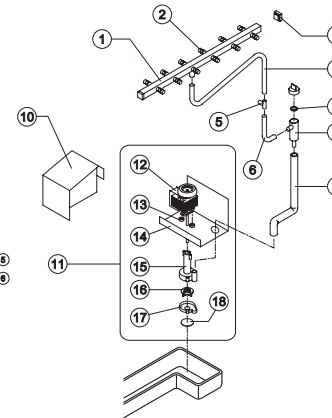
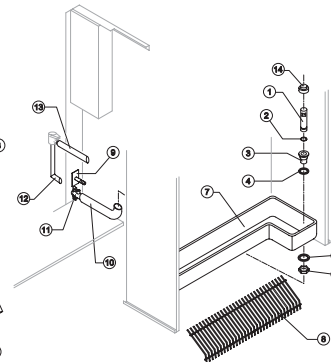
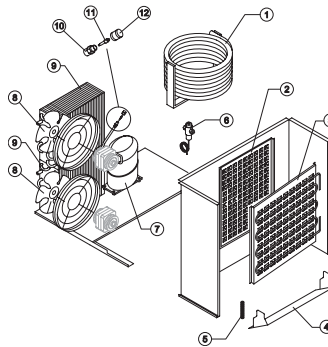
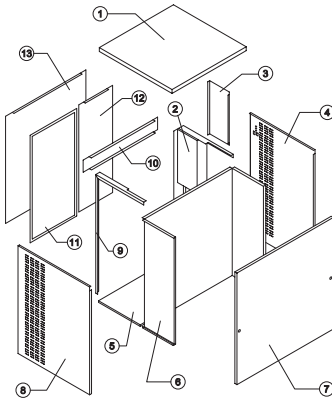

SHELL ASSY

COOLING SYSTEM

HYDRAULIC CIRCUIT

SPRAYER PUMP

ELECTRIC PARTS

1st Version

Till s/n.141195

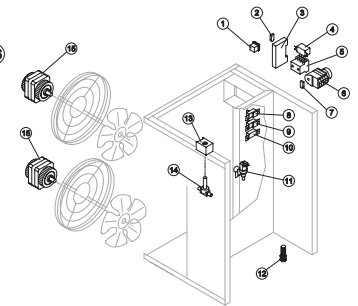
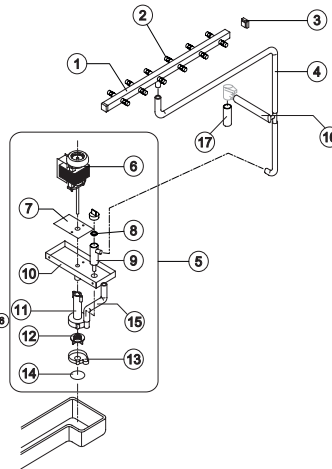
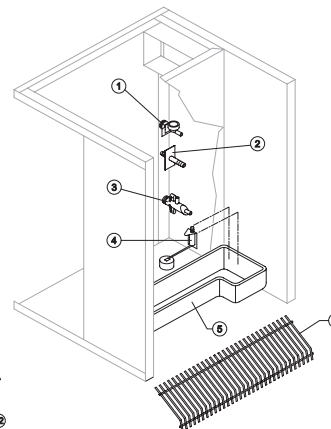
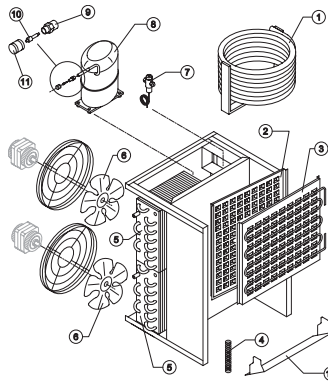
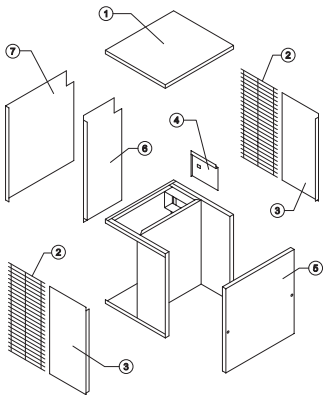

Rev. 3 - 2/7/2003

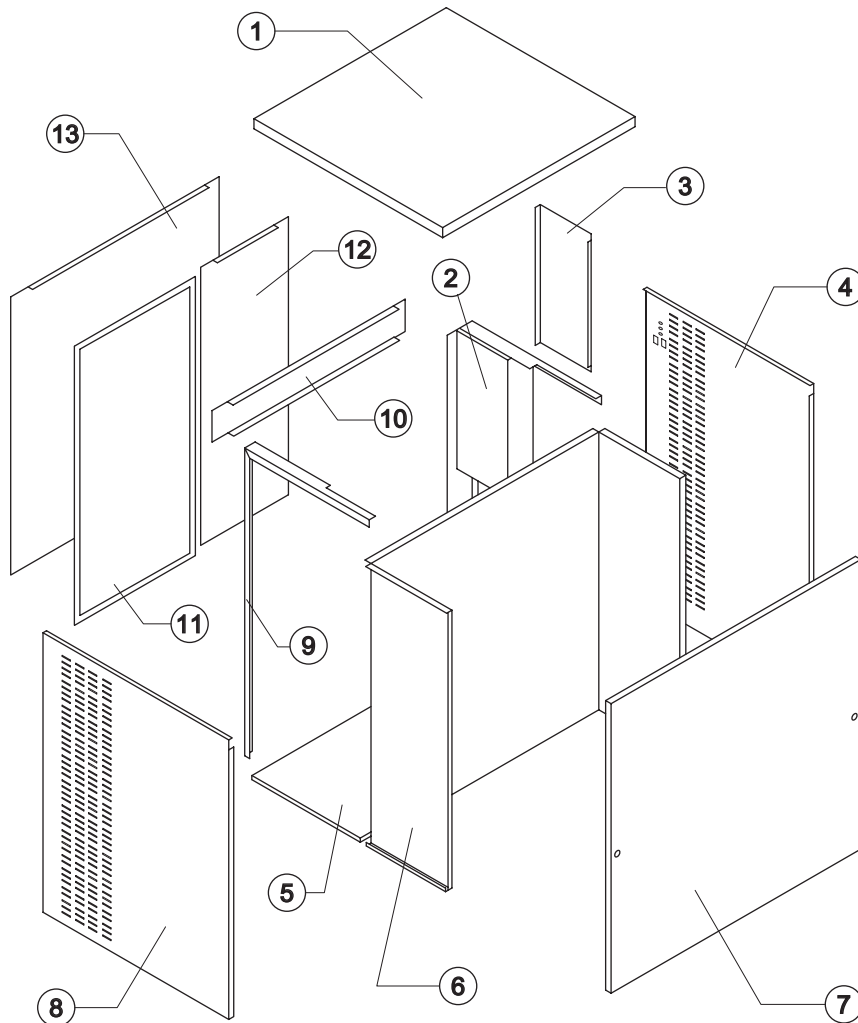

Rev. 3 - 2/7/2003

Common Parts

Ref.	Spare Description	Code
1	Top Assembly	C22813
2	Right Bent	22814
3	Electrical Box Cover	21274
4	Right Side	22821
5	Base Plate	22812
6	Evaporator Housing Panel	22819
7	Front Panel Assembly	C22816
8	Left Side	22822
9	Left Bent	22820
10	Back Transom	22817

Parts for Air-Cooled Version Only

Ref.	Spare Description	Code
11	Filter	18166
12	Back Panel	21287

Parts for Water-Cooled Version Only

Ref.	Spare Description	Code
13	Back Panel	21285

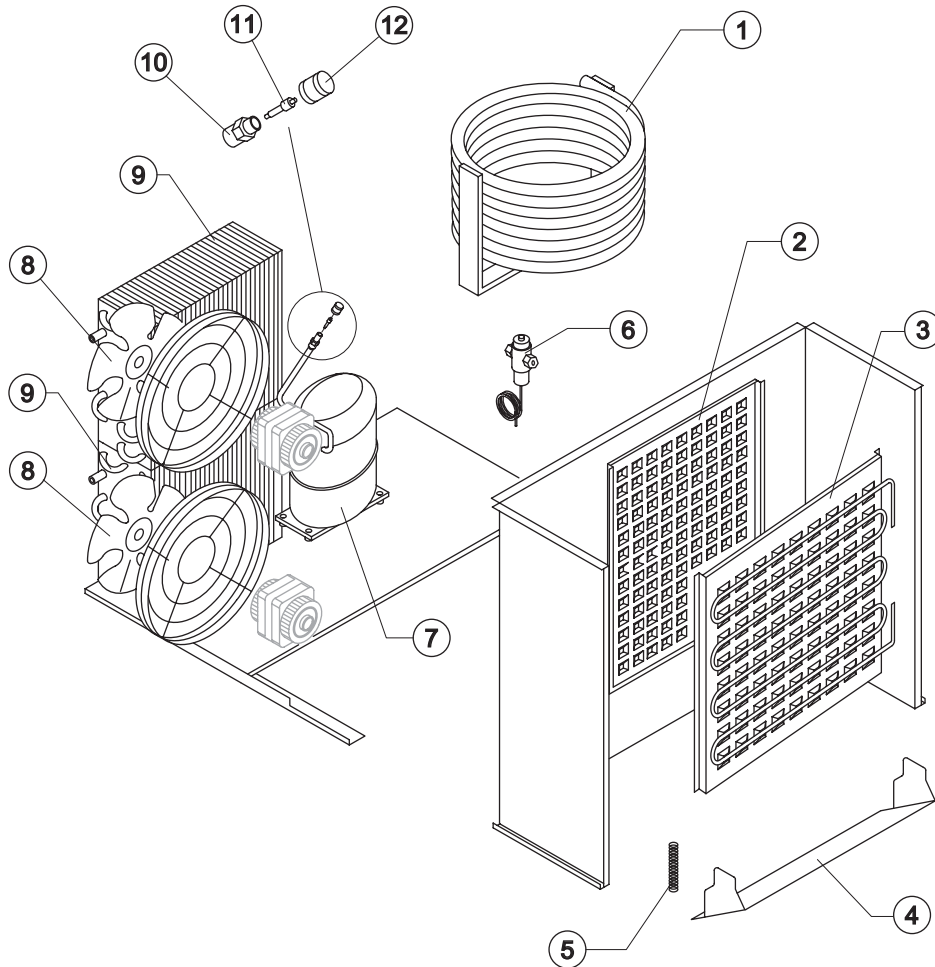

Common Parts

Ref.	Spare Description	Code
2	Evaporator (Back)	D10227
3	Evaporatore (Front)	D10228
4	Horizontally Hinged	22608-3
5	Spring	20464
7	Compressor	See Table -
10	Vacuum-Charge Valve Body	14007
11	Vacuum-Charge Valve Device	14005
12	Vacuum-Charge Valve Plug	14006

Parts for Air-Cooled Version Only

Ref.	Spare Description	Code
8	Suction Fan	20407
9	Air Condenser	20670

Parts for Water-Cooled Version Only

Ref.	Spare Description	Code
1	Water Condenser	14285
6	Pressure Valve	20149

Ref. 7 - Compressor

Tension		Code
220/240V 50 Hz	Current Version	23647
220/240V 50 Hz	Till s/n.173858	23489
220/230V 60 Hz	Current Version	23651
220/230V 60 Hz	Till s/n. 173885	23527



Common Parts

Ref.	Spare Description	Code
1	Overflow Pipe	10399
2	OR Gasket for Overflow Pipe	20233
3	Overflow Pipe Nipple	10241
4	Silicone Gasket	13006
5	Semirigid Polyethylene Gasket	13007
6	Bin Discharge Nut	10096
7	Water Basin	10395
8	Ice Cubes Slide	D12057
10	Overflow Pipe Nipple	13120
11	Drain Nipple	10431
12	Discharge Valve Connection Pipe - Discharge	13040
13	Discharge Valve Connection Pipe ("T"Shaped)	13102
14	Overflow Cap	10305

Parts for Water-Cooled Version Only

Ref.	Spare Description	Code
9	Rubber Holder with Plate	C20462

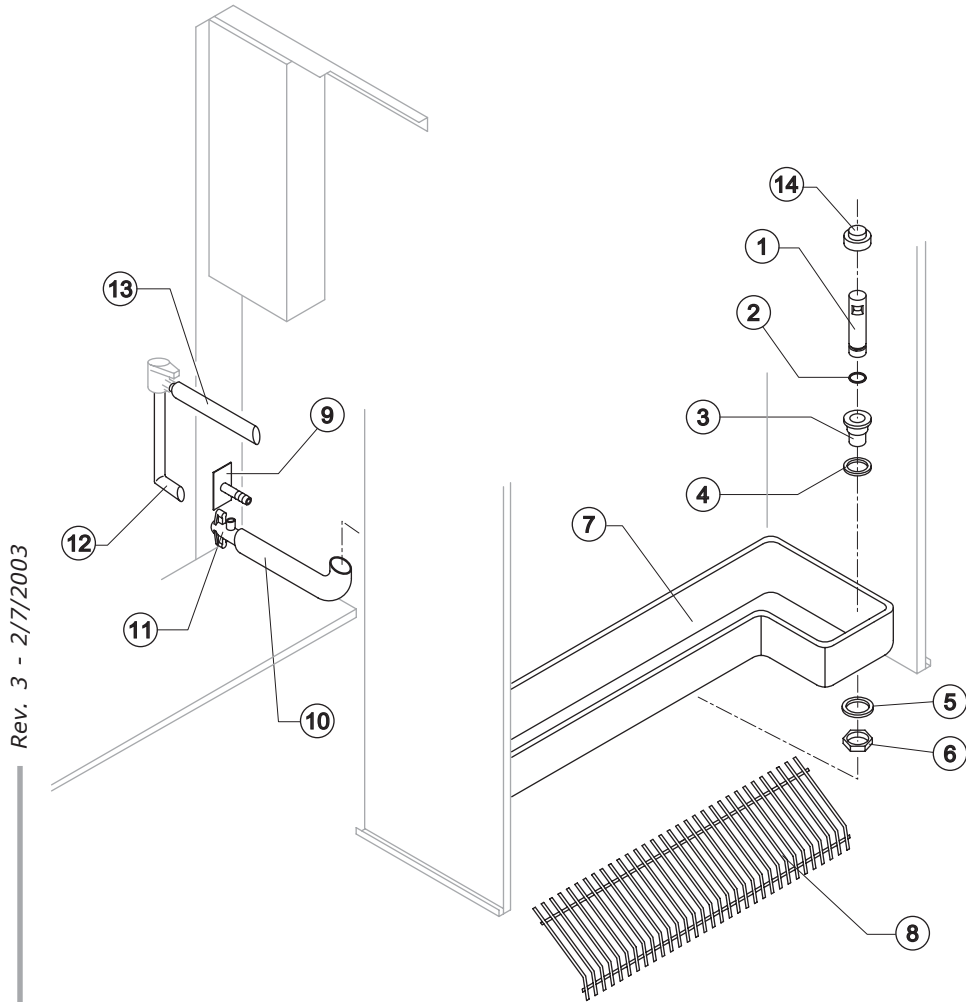

Rev. 3 - 2/7/2003



VM 900

2nd Version From s/n.141196 up Today

SPRAYER PUMP

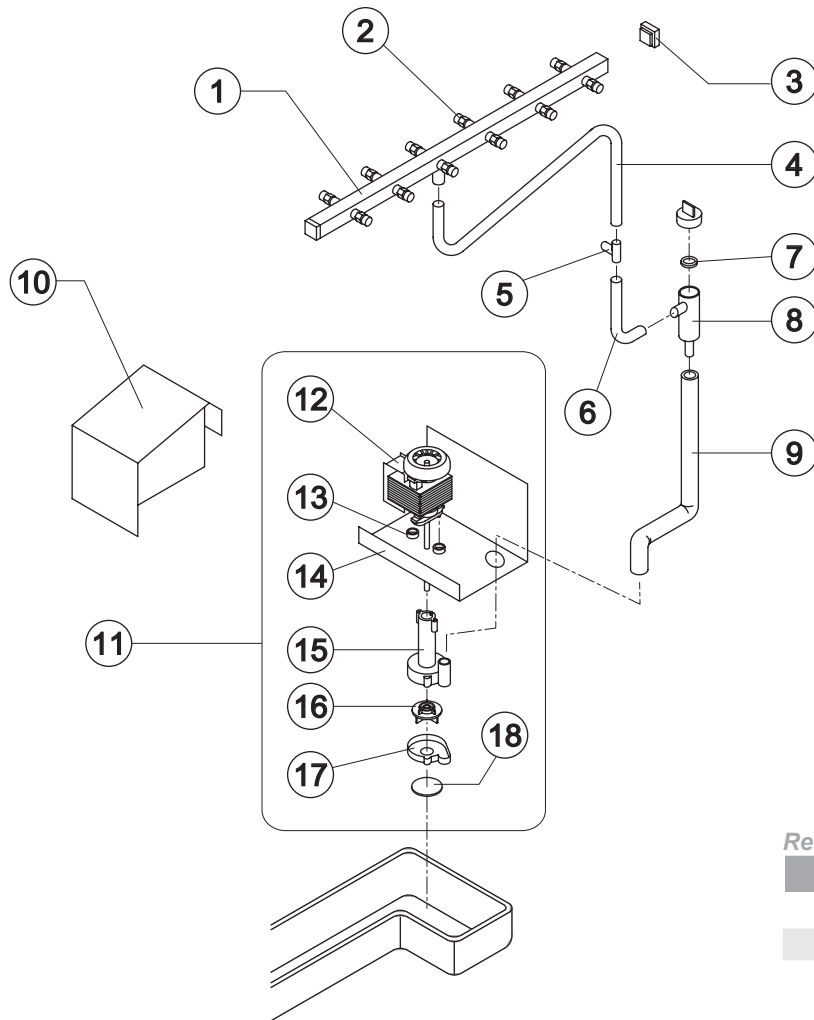

Ref.	Spare Description	Code	
1	Sprayers Bar Assembly	C20617	
2	Sprayer	D20463	
3	Sprayers Bar Plug	10012	
4	Sprinkler Ba Connection Pipe ("T" Shaped)	13134	
5	Plastic "T" ø 20	10082	
6	Sprayers Feeding Pipe	13005	
7	Pump Filter Gasket	13080	
8	Pump Filter	10139	
9	Sylicon Pipe ø 16/22	13111	
10	Protection Pump Panel	22804	
11	Pump Assembly	See Table	-
12	Pump Motor	See Table	-
13	Thickness Pump Motor		20510
14	Pump Motor Support		22799
15	Pump Body		10065
16	Pump Impeller	See Table	-
17	Diffuser		10067
18	Pump Filter		20518

Ref. 11 - Pump Assembly

Tension	Code
220/240V 50 Hz	C23626
220/230V 60 Hz	C23627

Ref. 12 - Pump Motor

Tension	Code
220/240V 50 Hz	23600
220/230V 60 Hz	23601

Ref. 16 - Pump Impeller

Tension	Code
220/240V 50 Hz	10066
220/230V 60 Hz	10138

Rev. 3 - 2/7/2003

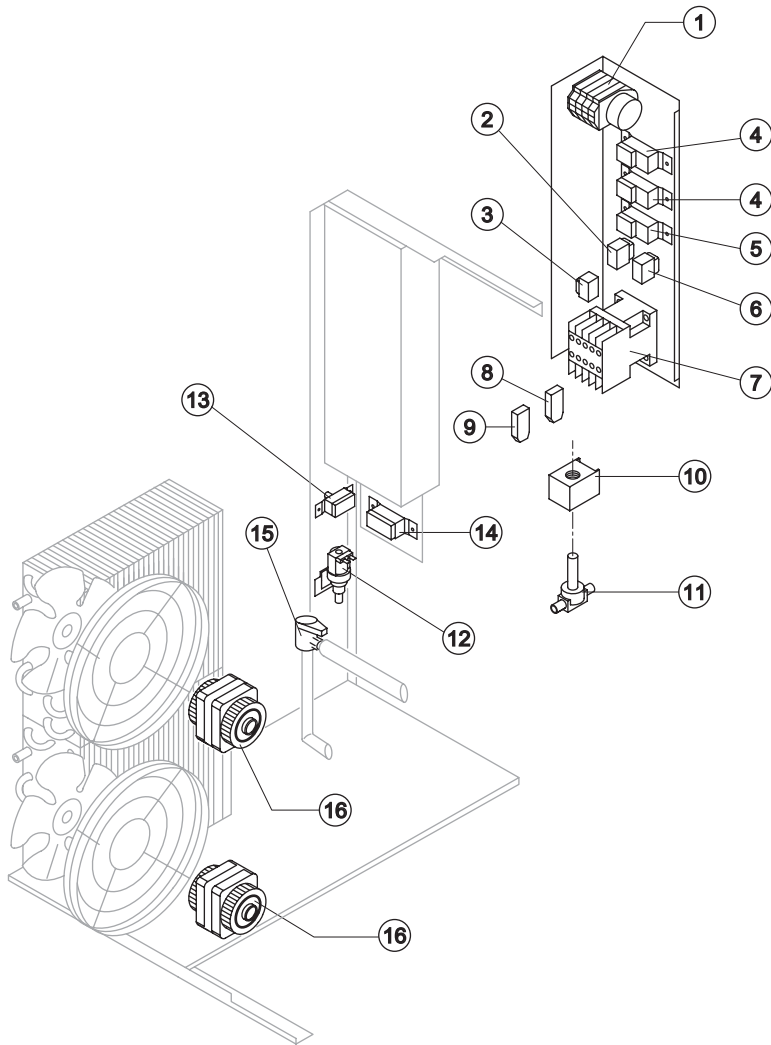

Common Parts

Ref.	Spare Description	Code
1	Timer	See Table
2	Light Switch "Economy-Full"	23611
3	"Washing" Switch	23619
4	Bin Thermostat	23005
5	Evaporator Thermostat	23597
6	Green Light Switch	23327
7	Contactor	23147
10	Hot Gas Coil	23091
11	Hot Gas Valve Body	20409
12	Inlet Watervalue 1 Way	23623
13	Safety Pressure Switch	23342
15	Outlet Water Valve	23537

Parts for Air-Cooled Version Only

Ref.	Spare Description	Code
8	Anti Radio Interference Filter	Only 220V 50 Hz
9	Anti Radio Interference Filter	Only 220V 50 Hz
14	Condenser Pressure Switch	23175
16	Fan Motor	23121

Ref. 1 - Timer

Tension	Code
220/240V 50 Hz	23635
220/230V 60 Hz	23632

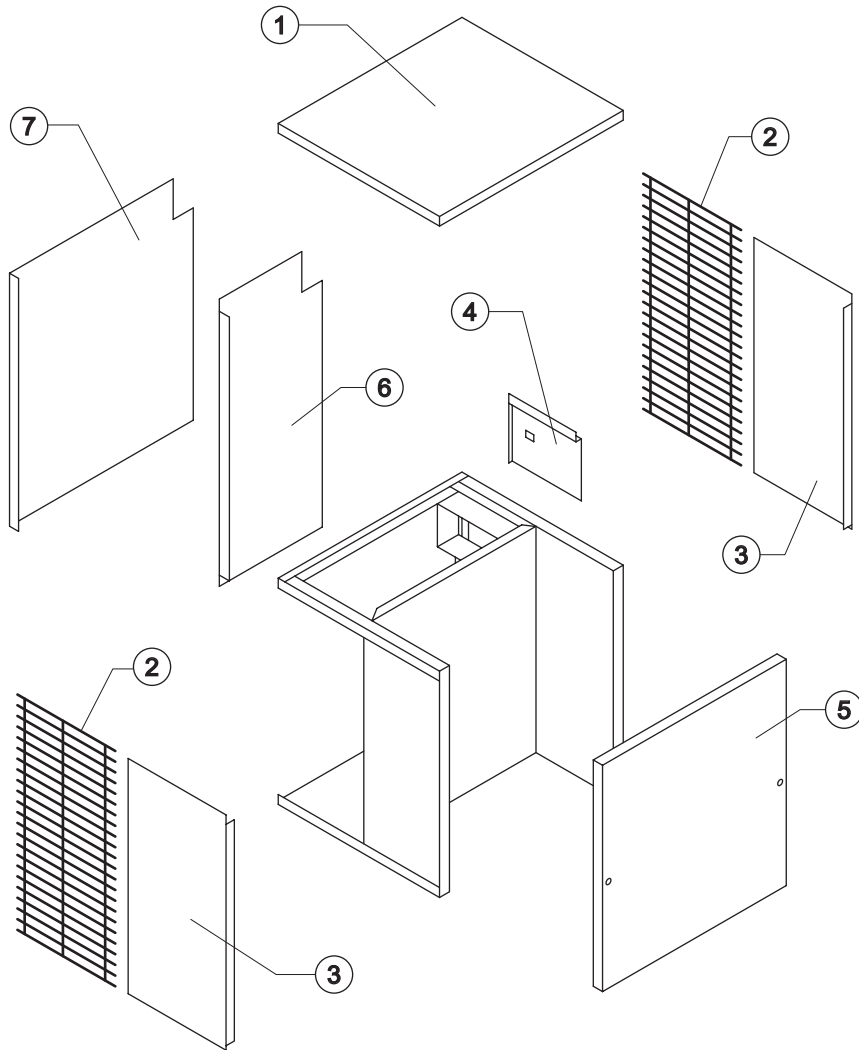

Rev. 3 - 2/7/2003

Common Parts

Ref.	Spare Description	Code
1	Top Assembly	C22607
2	Lateral Grid (Right & Left)	D12055
3	Right Side & Left Side	22606
4	Electrical Box Cover	Current Version 21231
4	Electrical Box Cover	Till s/n. 81707 21222
5	Front Panel Assembly	C22604

Parts for Air-Cooled Version Only

Ref.	Spare Description	Code
6	Back Panel	21217

Parts for Water-Cooled Version Only

Ref.	Spare Description	Code
7	Back Panel	21223

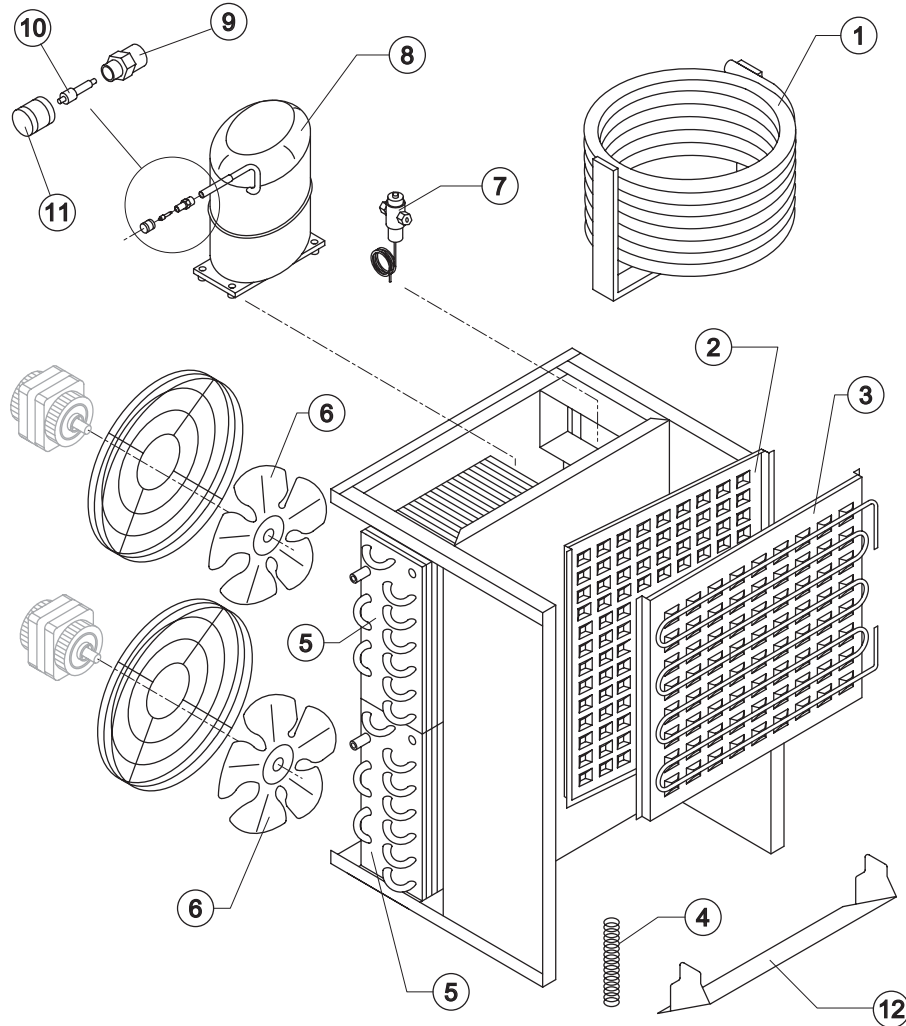

Common Parts

Ref.	Spare Description	Code
2	Evaporator (Back)	D10227
3	Evaporator (Front)	D10228
4	Spring	20464
8	Compressor	See Table
9	Vaccum-Charge Valve Body	14007
10	Vaccum-Charge Valve Device	14005
11	Vaccum-Charge Valve Plug	14006
12	Horizontally Hinged	22608

Parts for Air-Cooled Version Only

Ref.	Spare Description	Code
5	Air Condenser	20670
6	Suction Fan	20407

Parts for Water-Cooled Version Only

Ref.	Spare Description	Code
1	Water Condenser	14285
7	Pressure Valve Switch	20149

Ref. 8 - Compressor

Tension	Code
220/240V 50 Hz	23489
220/230V 60 Hz	23527
400V 3N 50 Hz	23453

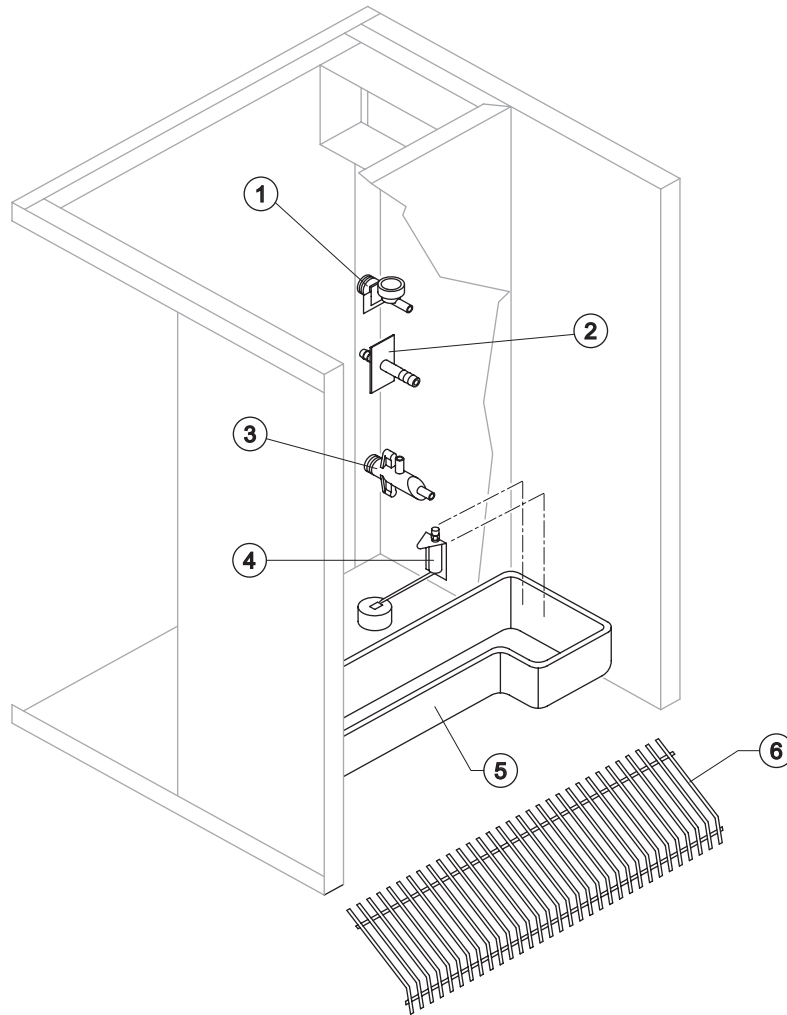

Common Parts

Ref.	Spare Description	Code
1	1 way Inlet Water Nipple	10239
4	Floating Valve	10188
5	Water Basin	10236
6	Ice Cubes slide	D12057

Parts for Air-Cooled Version Only

Ref.	Spare Description	Code
3	Discharges Manifold	C10052

Parts for Water-Cooled Version Only

Ref.	Spare Description	Code
2	Rubber Holder with plate	C20462
3	Discharges Manifold	Current Version C10052
3	Discharges Manifold	Till s/n. 127939 C10053

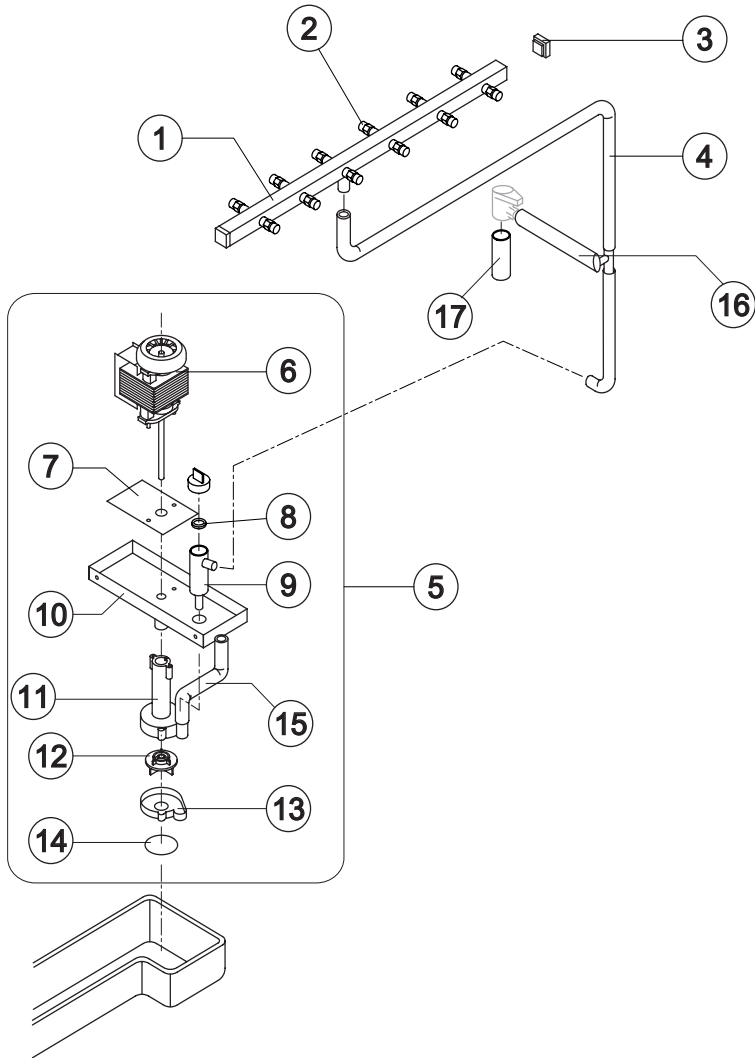

Ref.	Spare Description	Code	
1	Sprayers Bar assembly	C20466	
2	Sprayer	D20463	
3	Sprayers Bar Plug	10012	
4	Filter-Sprayers Pipe Connection	13103	
5	Pump Assembly	See Table	-
6	Pump Motor	See Table	-
7	Heat Dissipator	22430	
8	Pump Filter Gasket	13080	
9	Pump Filter	10139	
10	Pump Motor Support	10161	
11	Pump Body	10065	
12	Pump Impeller	See Table	-
13	Diffuser	10067	
14	Pump Filter	20518	
15	Pump - Filter Connection Pipe	13084	
16	Discharge Valve Connecting Pipe ("T" Shaped)	13102	
17	Connecting Pipe Water Outlet Valve Manifold	13104	

Ref. 5 - Pump Assembly

Tension	Code
220/240V 50 Hz	C23629
220/230V 60 Hz	C23630
400V 3N 50 Hz	C23629

Ref. 6 - Pump Motor

Tension	Code
220/240V 50 Hz	23600
220/230V 60 Hz	23601
400V 3N 50 Hz	23600

Ref. 12 - Pump Impeller

Tension	Code
220/240V 50 Hz	10066
220/230V 60 Hz	10138
400V 3N 50 Hz	10066



Common Parts

Ref.	Spare Description	Code
1	Green Light Switch	23327
3	Electronic Timer	23560
4	Relay	23190
5	Contactors	23147
6	Timer	See Table
8	Safety Pressure Switch	23342
10	Evaporator Thermostat	23597
11	Outlet Water Valve	23537
12	Closeness Switch	23540
13	Hot Gas Coil	23091
14	Hot Gas Valve Body	20409

Parts for Air-Cooled Version Only

Ref.	Spare Description	Code
2	Anti Radio Interference Filter	Only 220V e 400V 3N 50 Hz 23458
7	Anti Radio Interference Filter	Only 220V e 400V 3N 50 Hz 23459
9	Condenser Pressure Switch	23175
15	Fan Motor	23121

Ref. 6 - Timer

Tension	Code
220/240V 50 Hz	23539
220/230V 60 Hz	23559
400V 3N 50 Hz	23539

Rev. 3 - 2/7/2003

