

G & E401 CONTROL PANEL

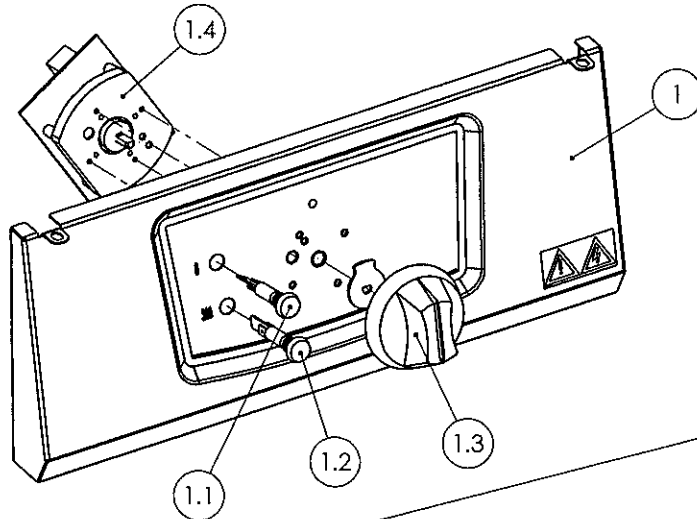

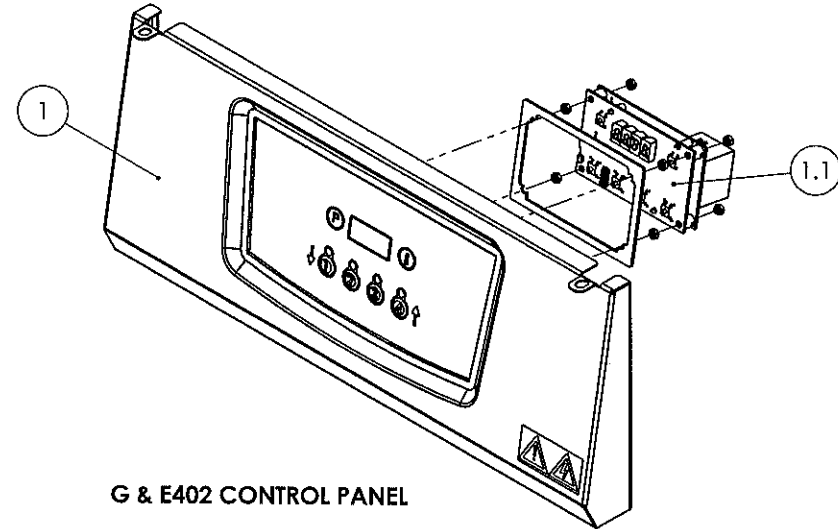

ITEM	DESCRIPTION	SPARES No.
1	CONTROL PANEL ASSEMBLY	731350000
1.1	RED NEON	735010370
1.2	AMBER NEON	735010380
1.3	CONTROL KNOB C/W STOP	731350001
1.4	CONTROLLER	731350002

ITEM	DESCRIPTION	SPARES No.
1	CONTROL PANEL ASSEMBLY	731360000
1.1	CONTROLLER C/W SPACER	731360001

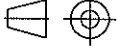

G & E402 CONTROL PANEL

CLEARED FOR PRODUCTION

ISSUE	MOD No	ALTERATION	DRAWN BY	DATE	IF IN DOUBT ASK DO NOT SCALE FIRST ANGLE PROJECTION  UNLESS OTHERWISE SPECIFIED: DIMENSIONS ARE IN MILLIMETERS TOLERANCES: LINEAR: ±0.5mm ANGULAR: ±0.5 DEG DEBUR AND BREAK SHARP EDGES WEIGHT: 1191315.75g	DRAWN: G.SMITH	PRODUCT	DRAWING NUMBER	ISSUE
A	1234/10	PRODUCTION ISSUE	G.SMITH	22/11/10			DATE: 22/11/10	G & E401/402 SINGLE PAN FRYERS	AD48017
					SCALE:		TITLE	SPARES - CONTROL PANELS	
						MATL:			
						THICKNESS:	FINISH:		
						BIN No:	PART No:		

© NO REPRODUCTION OR PUBLICATION OF THIS DRAWING MAY BE MADE AND NO ARTICLE MAY BE MANUFACTURED OR ASSEMBLED IN ACCORDANCE WITH THIS DRAWING WITHOUT PRIOR WRITTEN CONSENT. THIS PROHIBITION IS A TERM OF ANY CONTRACT RELATING TO THIS DRAWING. RIGHTS RESERVED UNDER THE COPYRIGHT ACT 1956 AS AMENDED BY THE DESIGN COPYRIGHT ACT 1968

MODEL SHOWN - E402F

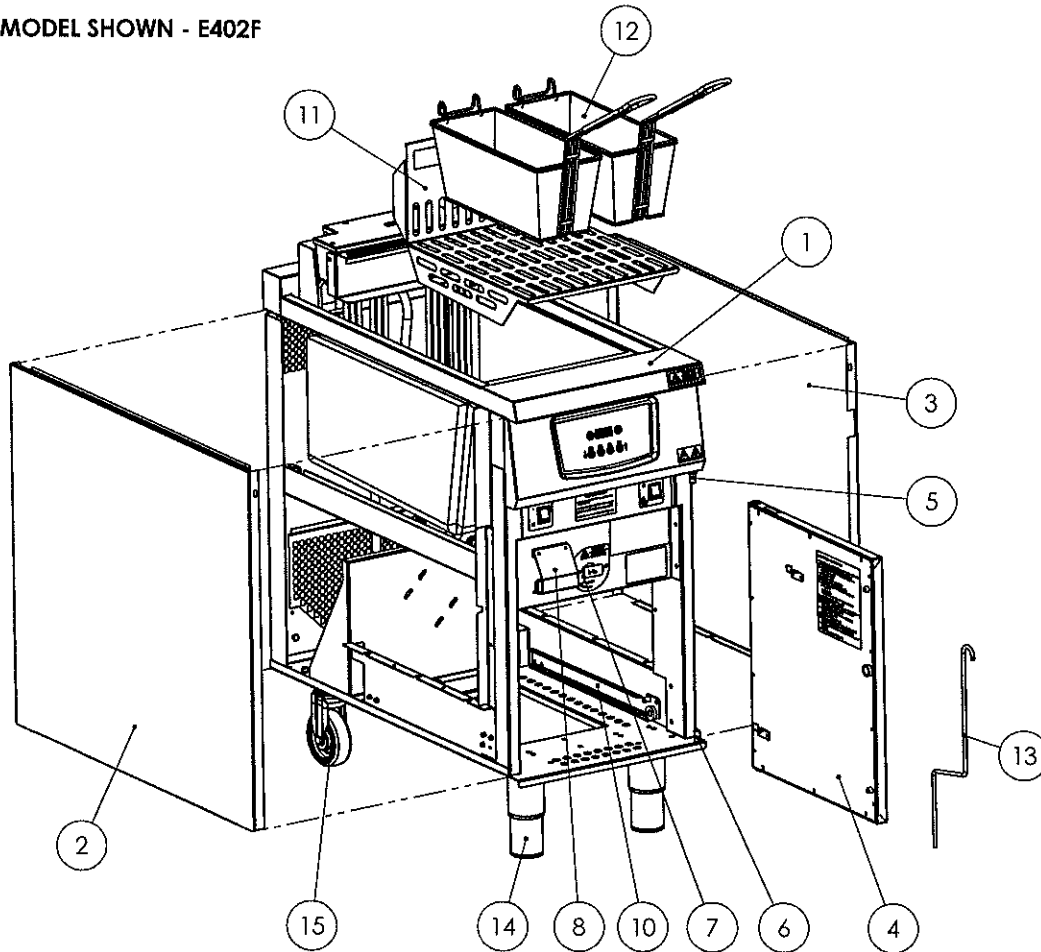

ITEM	DESCRIPTION	SPARES No
1	HOB / PAN ASSEMBLY C/W DRAIN VALVE	731350003
2	LH OUTER SIDE	731350004
3	RH OUTER SIDE	731350005
4	DOOR ASSEMBLY	731350006
5	TOP DOOR HINGE	536430108
6	BOTTOM DOOR HINGE PIN	536430109
7	DRAIN HANDLE	731350007
8	DRAIN HANDLE FLAP	731350008
9	LH BUCKET RUNNER (NOT SHOWN)	731350009
10	RH BUCKET RUNNER	731350010
11	ELEMENT GUARD	731350011
12	CHIP BASKET	536430126
13	DRAIN PROD / LIFTING TOOL	731350012
14	ADJUSTABLE FEET	731350013
15	CASTORS	731350014

CLEARED FOR PRODUCTION

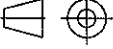
ISSUE	MOD No	ALTERATION	DRAWN BY	DATE	IF IN DOUBT ASK DO NOT SCALE FIRST ANGLE PROJECTION  UNLESS OTHERWISE SPECIFIED: DIMENSIONS ARE IN MILLIMETERS TOLERANCES: LINEAR: ±0.5mm ANGULAR: ±0.5 DEG DEBUR AND BREAK SHARP EDGES WEGH: 1191329.65g	DRAWN: G.SMITH	PRODUCT	E401/402 SINGLE PAN FRYER SPARES - MAIN BODY	DRAWING NUMBER	ISSUE
A	1234/10	PRODUCTION ISSUE	G.SMITH	23/11/10		DATE: 23/11/10	TITLE			
© NO REPRODUCTION OR PUBLICATION OF THIS DRAWING MAY BE MADE AND NO ARTICLE MAY BE MANUFACTURED OR ASSEMBLED IN ACCORDANCE WITH THIS DRAWING WITHOUT PRIOR WRITTEN CONSENT. THIS PROHIBITION IS A TERM OF ANY CONTRACT RELATING TO THIS DRAWING. RIGHTS RESERVED UNDER THE COPYRIGHT ACT 1956 AS AMENDED BY THE DESIGN COPYRIGHT ACT 1968						MATL:	FINISH:	PART No:		
						THICKNESS:				
						BIN No:				



Falcon Foodservice Equipment Wallace View Hillfoots Road Stirling Scotland

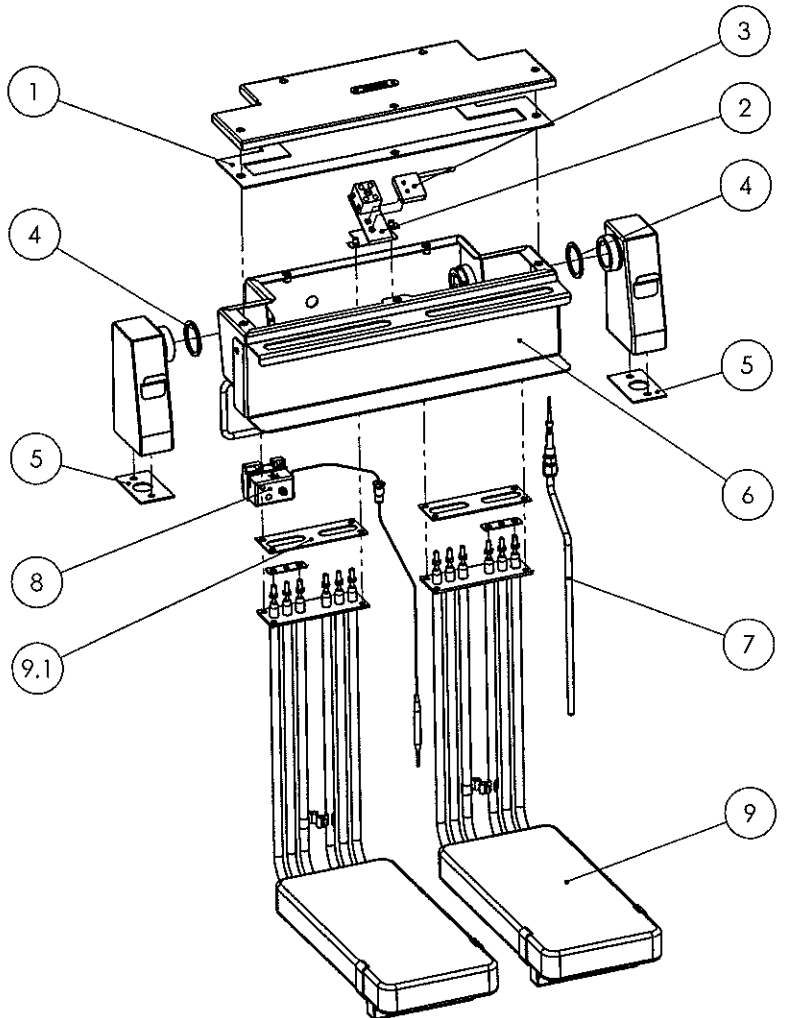

ITEM	DESCRIPTION	SPARES No
1	ELEMENT BOX LID GASKET	731350015
2	TILT SWITCH BRACKET	731350016
3	TILT SWITCH	735750014
4	ELEMENT BOX CABLE GASKET	731350017
5	ELEMENT BOX SUPPORT GASKET	731350018
6	BASKET HANGING RAIL	731350019
7	THERMISTOR PROBE C/W FITTINGS	731350020
8	SAFETY STAT C/W FITTINGS	731350021
9	ELEMENT C/W GASKET	731350022
9.1	ELEMENT GASKET	731350023

CLEARED FOR PRODUCTION

ISSUE	MOD No	ALTERATION	DRAWN BY	DATE
A	1234/10	PRODUCTION ISSUE	G.SMITH	23/11/10

IF IN DOUBT ASK
DO NOT SCALE
FIRST ANGLE PROJECTION

UNLESS OTHERWISE SPECIFIED:
DIMENSIONS ARE IN MILLIMETERS
TOLERANCES:
LINEAR: ±0.5mm
ANGULAR: ±0.5 DEG

DEBUR AND
BREAK SHARP EDGES

WEIGHT: 1191329.65g



DRAWN: G.SMITH	PRODUCT	E401/402 SINGLE PAN FRYER	
DATE: 23/11/10	TITLE	SPARES - ELEMENTS / HOUSING	
SCALE:	MATL:	DRAWING NUMBER	ISSUE
THICKNESS:	FINISH:	AD48019	A
BIN No:	PART No:		

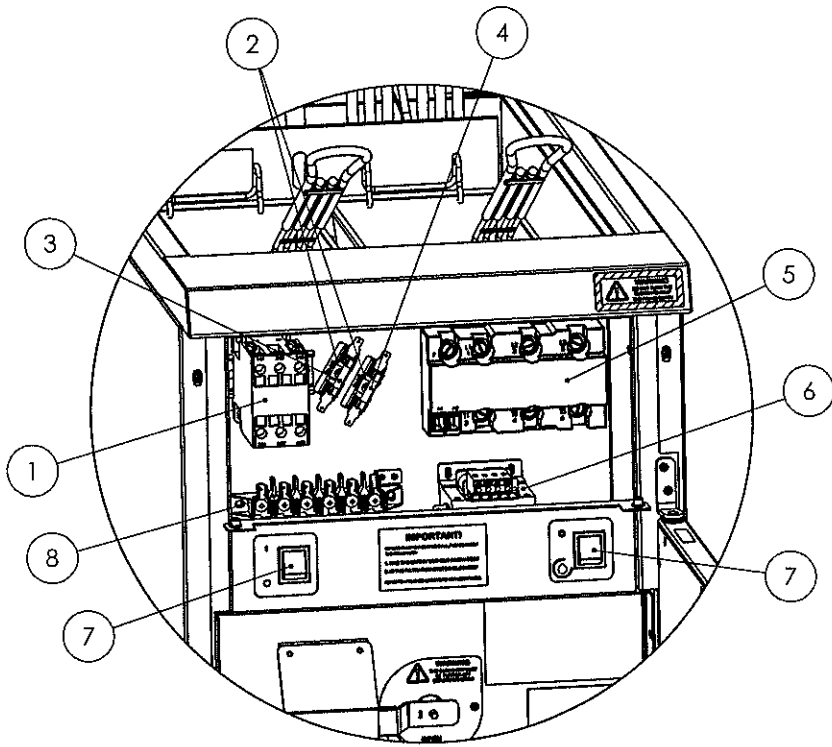

MODEL SHOWN - E402F

ITEM	DESCRIPTION	UNIT	SPARES No
1	CONTACTOR		734510010
2	FUSE HOLDER		731050002
3	2 AMP ANTI-SURGE FUSE		731050002
4	5 AMP ANTI-SURGE FUSE	FILTER MODELS ONLY	536430009
5	SOLID STATE POWER SWITCH		731350024
6	STEP-DOWN TRANSFORMER	402 ONLY	731360002
7	ROCKER SWITCH		732950006
8	MAINS TERMINAL BLOCK		731000006
9	MAINS INLET CABLE (NOT SHOWN)		731350025
10	MAINS INLET CABLE GLAND C/W NUT (NOT SHOWN)		731350026
11	MAIN WIRING LOOM (NOT SHOWN)	FILTER MODELS ONLY	731350027
12	MAIN WIRING LOOM (NOT SHOWN)	NON-FILTER MODELS	731370000
13	CONTROL PANEL WIRING LOOM (NOT SHOWN)	401 ONLY	731350028
14	CONTROL PANEL WIRING LOOM (NOT SHOWN)	402 ONLY	731360003

CLEARED FOR PRODUCTION

ISSUE	MOD No	ALTERATION	DRAWN BY	DATE
A	1234/10	PRODUCTION ISSUE	G.SMITH	22/11/10

IF IN DOUBT ASK
DO NOT SCALE
FIRST ANGLE PROJECTION

UNLESS OTHERWISE SPECIFIED:
DIMENSIONS ARE IN MILLIMETERS
TOLERANCES:
LINEAR: ±0.5mm
ANGULAR: ±0.5 DEG

DEBUR AND
BREAK SHARP EDGES

WEIGHT: 1191329.65g



DRAWN: G.SMITH	PRODUCT	E401/402 SINGLE PAN FRYER	
DATE: 22/11/10	TITLE	SPARES - ELECTRICS	
SCALE:	DRAWING NUMBER	AD48020	ISSUE
MATL:	FINISH:		A
THICKNESS:	PART No:		
BIN No:			

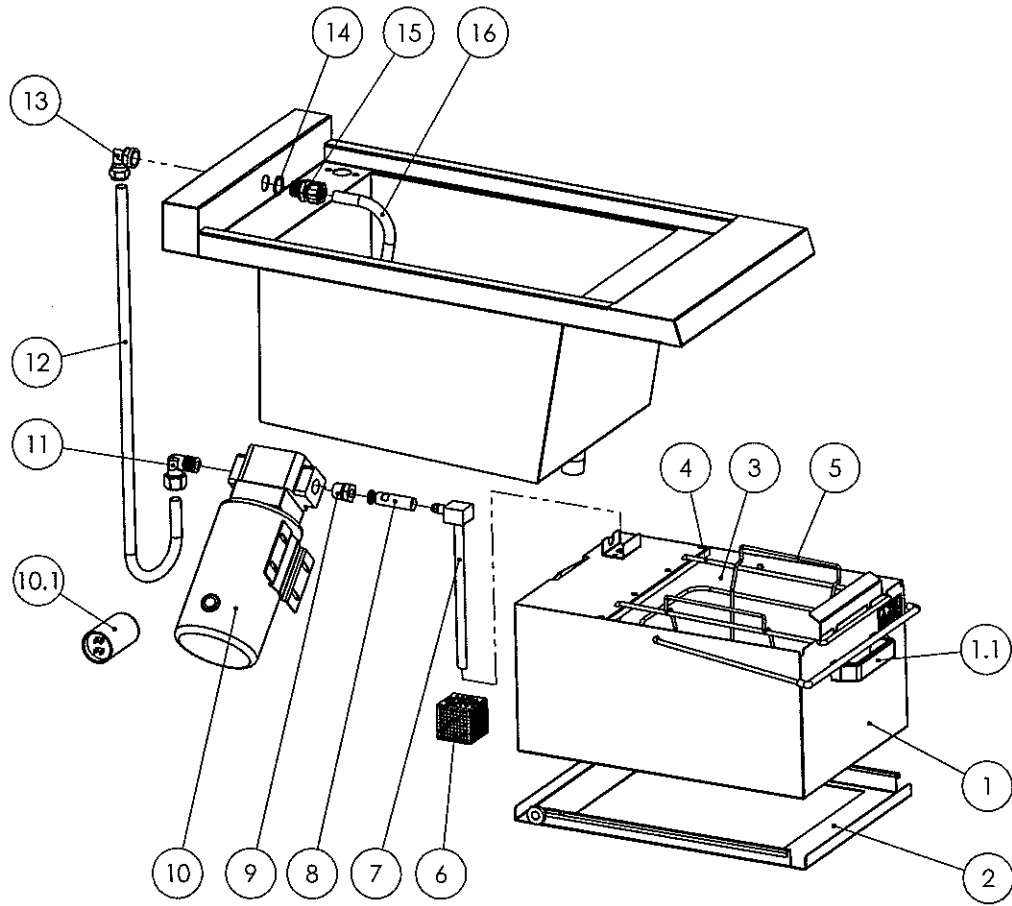

ITEM	DESCRIPTION	SPARES No
1	OIL CONTAINER ASSEMBLY	731350029
1.1	OIL CONTAINER FRONT HANDLE	731350030
2	OIL CONTAINER CARRIER	535770028
3	FINE MESH FILTER	737101159
4	FINE MESH FILTER WIRE SUPPORT	737101143
5	BASKET FILTER	731350031
6	SUCTION PIPE FILTER	731350032
7	SUCTION PIPE C/W 'O' RING	731350033
7.1	SUCTION PIPE 'O' RING (NOT SHOWN)	731350034
8	OIL INLET NOZZLE C/W WASHER	731350035
9	REDUCER	731350036
10	OIL PUMP	731350037
10.1	OIL PUMP CAPACITOR	731350038
11	PUMP ELBOW	731350039
12	OIL PUMP OUTLET PIPE	731350040
13	OIL RETURN ELBOW	731350041
14	OIL RETURN PIPE GASKET	731350042
15	OIL RETURN COUPLING	731350043
16	OIL RETURN PIPE	731350044

CLEARED FOR PRODUCTION

ISSUE	MOD No	ALTERATION	DRAWN BY	DATE	IF IN DOUBT ASK DO NOT SCALE FIRST ANGLE PROJECTION 	DRAWN: G.SMITH	PRODUCT	E401F / E402F SINGLE PAN FRYER	
A	1234/10	PRODUCTION ISSUE	G.SMITH	23/11/10		UNLESS OTHERWISE SPECIFIED: DIMENSIONS ARE IN MILLIMETERS TOLERANCES: LINEAR: ±0.5mm ANGULAR: ±0.5 DEG	DATE: 23/11/10	TITLE	SPARES - FILTRATION
					DEBUR AND BREAK SHARP EDGES WEIGHT: 1191329.65g	SCALE:	MATL:	DRAWING NUMBER	ISSUE
© NO REPRODUCTION OR PUBLICATION OF THIS DRAWING MAY BE MADE AND NO ARTICLE MAY BE MANUFACTURED OR ASSEMBLED IN ACCORDANCE WITH THIS DRAWING WITHOUT PRIOR WRITTEN CONSENT. THIS PROHIBITION IS A TERM OF ANY CONTRACT RELATING TO THIS DRAWING. RIGHTS RESERVED UNDER THE COPYRIGHT ACT 1956 AS AMENDED BY THE DESIGN COPYRIGHT ACT 1968						THICKNESS:	FINISH:	AD48021	A
						BIN No:	PART No:		

