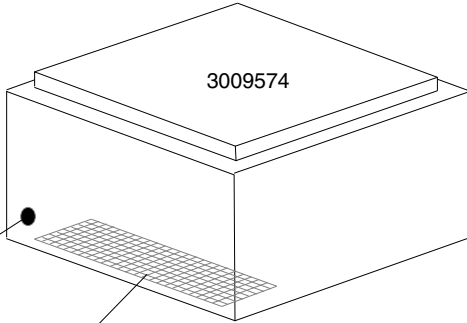
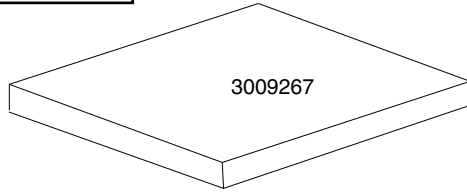
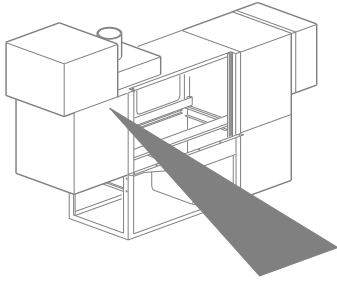
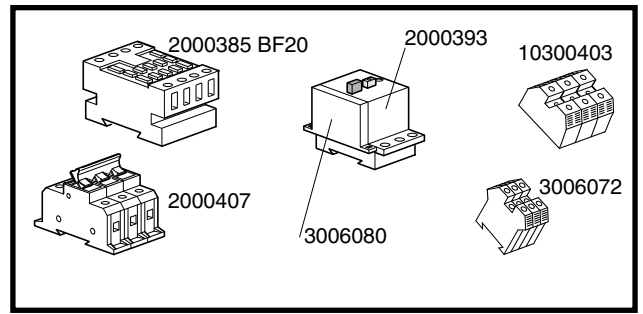

TABLE
KI9110

REV
02

OPTIONAL ASCIUGAT. K11/A (6-Kw)

OPTIONAL DRYING K11/A (6-Kw)



13316

3009564

15105/A

3009104

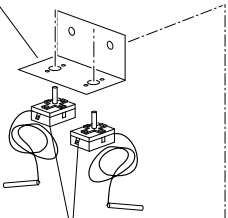

10707/2

11209



10200171



2000359

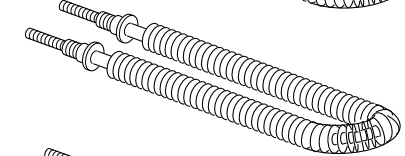

2000359

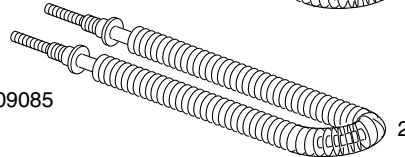

2000359

3009085

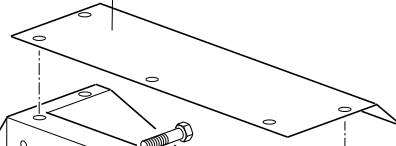

3009486 DX-RIGHT
3009487 SX-LEFT

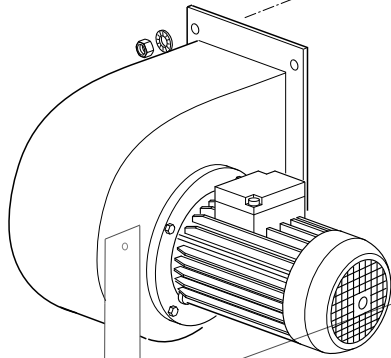

3009214

3000300

3000307 (0,75 HP 200V)



3009492

3009540

3009381

3009525

