

Ref.	Description	Refrigerant	A/W	Tension	Code
1	Foamed cabinet assy				C11086
2	Sprayers bar pipe connection assy				C13036
3	Pump suction filter				20005
4	Sprayers bar assembly				C20144
5	Sprayers bar plug				10012
6	Sprayer				D20002
7	Evaporator basin assembly				C10259
8	Overflow tube assembly				C10133
9	Overflow-discharge connection pipe				10256
10	Plastic nipple water outlet				10007
11	Back grid				D12021
12	Discharges manifold		A		C10006
12	Discharges manifold		W		C26452
13	Inlet watervalve 1 way		A	1-2	23108
13	Inlet watervalve 1 way		A	3	23281
13	Inlet water valve 2 ways		W	1-2	23157
13	Inlet water valve 2 ways		W	3	23282
14	Ice cubes slide				D12022
15	Back panel assembly				C21209
16	Evaporator cover				10058
17	Top assembly				C22688
18	Flags support assy				C22134
19	Door assembly				C10275
20	Bulbe thermostat tube				20521
21	Front grid panel				22564
22	Grid+frame				C10205
23	Filtering panel				18106
24	Foot h.100 mm				10040
25	Suction impeller			1-2	10213
26	Hub+washer+screw				10014
27	Pump motor			1-2	23068
27	Pump			3	23264
28	Pump delivery pipe				13095
29	Pump suction pipe				13096
31	Overflow pipe				13109

**Note:** Code C10133 from serial no. 62566. Previous serial no. code 13094.  
 Code 13109 from serial no. 62566. Previous serial no. code 13094.  
 Code 10256 from serial no. 62566. Previous serial no. code 22088.  
 Code 20521 from serial no. 94923. Previous serial no. code 20062.

**COOLING SYSTEM ASSEMBLY Mod. CB1265 A/W - Cube A (Cod. 24340)**

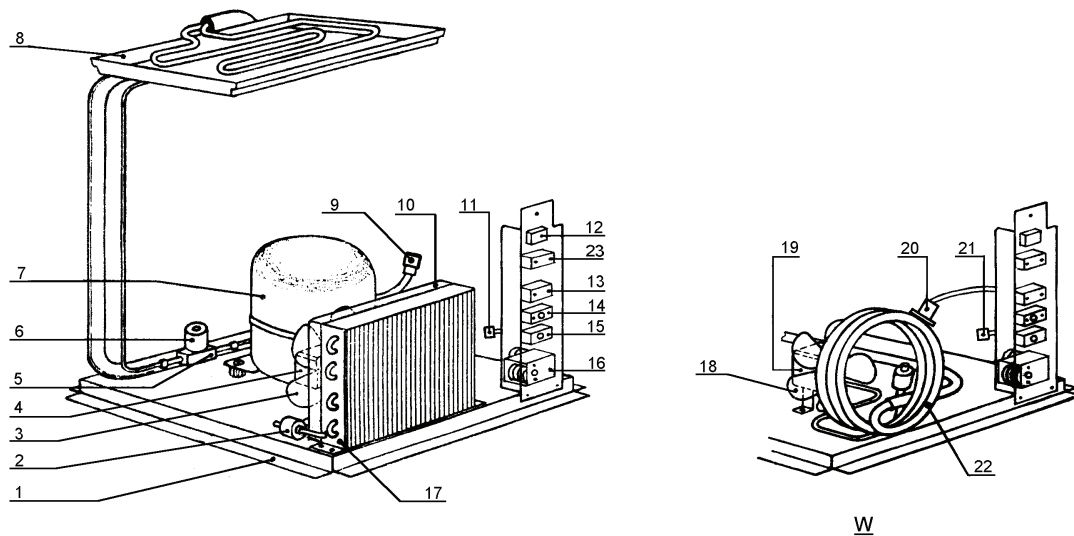

Ref.	Description	Refrigerant	A/W	Tension	Code
1	Base plate				C21210
2	Solid core drier				14089
3	Suction fan 254/34		A		20031
4	Lower fan motor		A	1	23067
4	Lower fan motor		A	2	23580
4	Fan motor		A	3	23393
5	Hot gas valve body				20409
6	Hot gas coil			1-2	23091
6	Hot gas coil			3	23256
7	Compressor			1	23440
7	Compressor			2	23465
7	Compressor			3	23554
8	Evaporator				D10214
9	Vacuum-charge valve device				14005
9	Vacuum-charge valve plug				14006
9	Vacuum- charge valve body				14007
10	Air condenser conveyer		A		10163
11	Anti radio interference filter		A	1	23459
12	Green light switch				23327
13	Condenser pressure switch				23175
14	Bin thermostat				23005
15	Evaporator thermostat				23591
16	Timer			1	23222
16	Timer			2	23248
16	Timer			3	23259
17	Air condenser		A		20264
18	Suction impeller		W		10213
19	Fan motor		W	1-2	23029
19	Fan motor		W	3	23265
20	Safety thermostat		W		C23114
21	Anti radio interference filter		W	1	23457
22	Water condenser		W		14034
23	Contacteur			3	23595

**Note:**

### **Erklärung zu Ersatzteillisten in den Spalten Tension-Spannung**

<b>1</b>	Spannung	220-240V	50Hz
<b>2</b>	Spannung	220-230V	60Hz
<b>3</b>	Spannung	110 115V	60Hz
<b>4</b>	Spannung	230V3P	50Hz
<b>5</b>	Spannung	400V	50Hz
<b>6</b>	Spannung	220-230V3P	60Hz
<b>7</b>	Spannung	440-460V3P	60Hz