

AC 125 B & C - AC 175

Electronic cuber with storage

Spare parts list
Catalogo ricambi
Catalogues pièces détachées
Ersatzteilkatalog

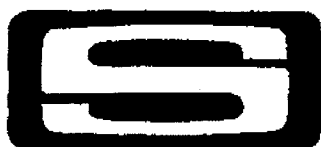
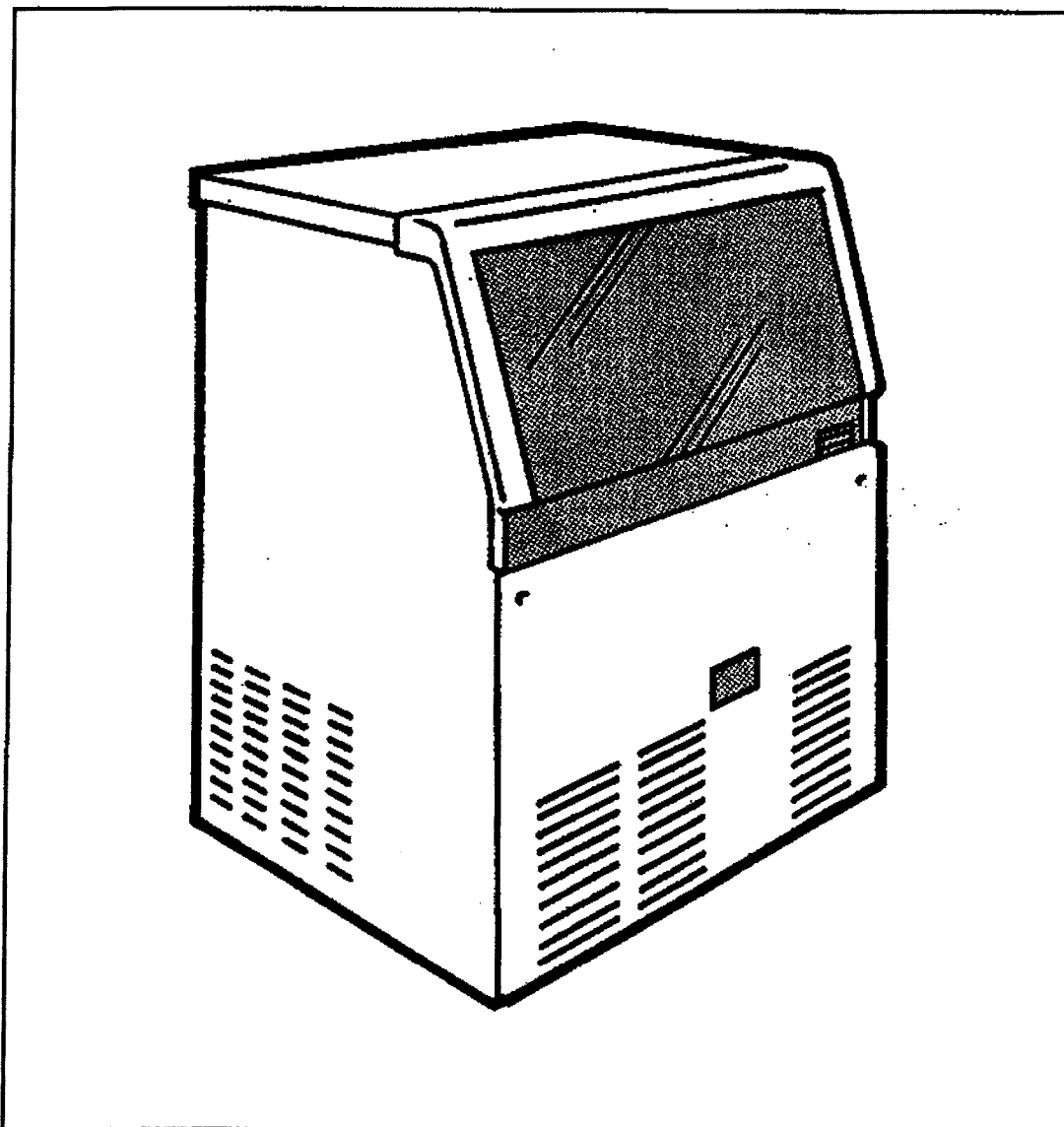

SCOTSMAN®

ICE SYSTEMS

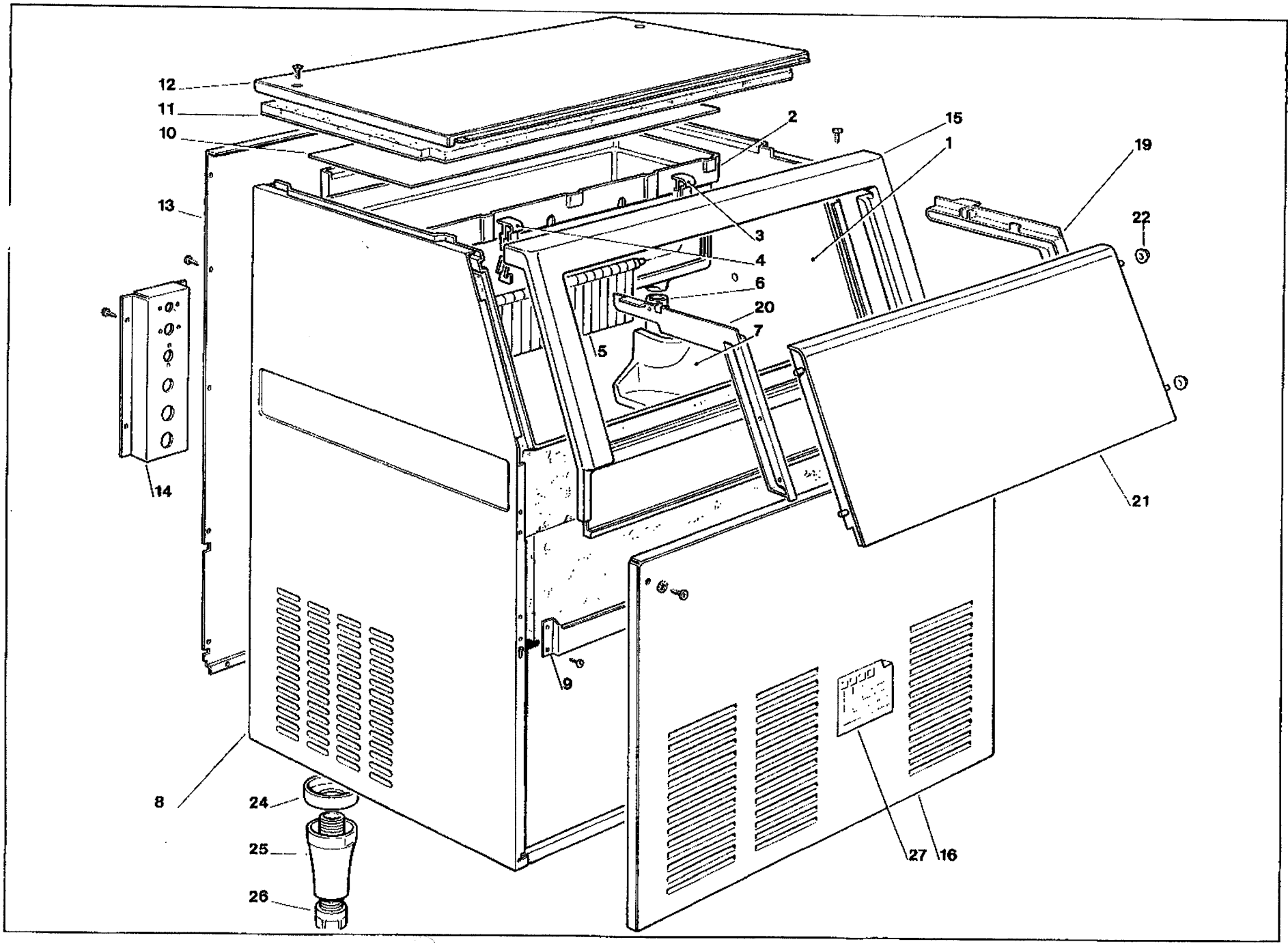

ACM 125 B - UNIT PANELS - ASSIEME MOBILE - ENS. CARROSSERIE - MACHINE GEHAUSE

ITEM NO POS NO REP. NO REF. NO	PART NO CODICE REFERENCE STUECK NR	DESCRIPTION	DESCRIZIONE	DESIGNATION	BESCHREIBUNG
1	782060 07	INSULATED STORAGE BIN	ASSIEME CELLA ISOLATA	CABINE DE STOCKAGE ISOLEE	ISOLIEREISSPEICHER
2	660382 00	EVAPORATOR HOUSING	ALLOGGIAMENTO EVAPORATORE	CUVE - ÉVAPORATEUR	VERDAMPFER RAHMEN
3	660388 00	CURTAIN BRACKET RIGHT	SUPPORTO TENDINA DX	SUPPORT RIDEAU DROITE	JALOUSIE RECHTEHALTERUNG
4	660388 01	CURTAIN BRACKET LEFT	SUPPORTO TENDINA SX	SUPPORT RIDEAU GAUCHE	JALOUSIE LINKEHALTERUNG
5	784169 05	CURTAIN	TENDINA	RIDEAU	JALOUSIE
6	743112 01	PLASTIC PIPE	TUBO IN PLASTICA	TUYAU EN PLASTIQUE	PLASTIKROHR
7	660405 00	WATER RESERVOIR COVER	COPRIGANALINO	COUVERCLE RESERVOIR EAU	WASSERBECKENDECKEL
8	781307 10 781307 11	UNIT FRAME UNIT FRAME S.S.	ASSIEME TELAIO ASSIEME TELAIO ACCIAIO INOX	ENSAMBLE CHASSIS ENSAMBLE CHASSIS ACIER INOX	CHASSIS RAHMEN EDELSTHAL-CHASSIS REHMEN
9	702127 00	METAL BRACKET	SUPPORTO IN METALLO	SUPPORT METALLIQUE	METALLTRÄGER
10	741075 00	EVAPORATOR COVER	COPERCHIO EVAPORATORE	COUVERCLE ÉVAPORATEUR	VERDAMPFERDECKEL
11	794245 00	UPPER INSULATION	ISOLAMENTO SUPERIORE	ISOLATION SUPERIEUR	OBERE ISOLIERUNG
12	701798 00 701798 01	TOP PANEL TOP PANEL S.S.	PANNELLO SUPERIORE PANNELLO SUPERIORE ACC. INOX	PANNEAU SUPERIEUR PANNEAU SUPERIEURE ACIER INOX	ABDECKHAUBE ABDECKHAUBE EDELSTAHL
13	701928 00 701928 01	REAR PANEL REAR PANEL S.S.	PANNELLO POSTERIORE PANNELLO POSTERIORE ACC. INOX	PANNEAU ARRIERE PANNEAU ARRIERE ACIER INOX	REUCKWAND REUCKWAND EDELSTAHL
14	701993 00 701993 01	METAL BRACKET FOR FITTINGS METAL BRACKET FOR FITTINGS S.S.	SUPPORTO ATTACCHI SUPPORTO ATTACCHI ACC. INOX	SUPPORT DE RACCORDEMENTS SUPPORT DE RACC. ACIER INOX	ANSCHLUSSTÜCKMETALLTRÄGER ANSCHLUSSTÜCKMETALLTRÄGER EDELSTAHL
15	782078 00	BIN DOOR FRAME ASSY	ASSIEME CORNICE SPORTELLO	ENS. ENCADREMENT PORTE CABINE	TÜRRAHMEN
16	701796 04 701796 05	FRONT PANEL FRONT PANEL S.S.	PANNELLO FRONTALE PANNELLO FRONTALE ACCIAIO INOX	PANNEAU AVANT PANNEAU AVANT ACIER INOX	VORDERWAND VORDERWAND EDELSTAHL
19	660523 00	RIGHT BIN DOOR GUIDE	GUIDA SPORTELLO DESTRA	GLISSIER DE PORTE DROITE	RECHTESPEICHERTUERGLEIT
20	660523 01	LEFT BIN DOOR GUIDE	GUIDA SPORTELLO SINISTRA	GLISSIER DE PORTE GAUCHE	LINKESPEICHERTUERGLEIT
21	782009 07	BIN DOOR ASSY	ASSIEME SPORTELLO	ENSAMBLE PORTE CABINE	SPEICHERTUER
22	660286 00	DOOR RUNNER - BUSHING	BUSSOLE DI SCORRIMENTO	BAGUE DE COULISSAGE PORTE	TUERGLEITBUCHSE
24	660516 00	LEG SOCKET COLLAR	COPRIGHIERA PIEDINI	COLLIER DE SOCLE PIEDS	FUESSENIPPELNRING
25	660257 00	LEG	PIEDINO	PIED	FUESSE
26	660258 00	LEG LEVELLER	VITE DI REGOLAZIONE	VIS DE REGLAGE DES PIEDS	NIVELLIERUNGSHUELSE
27	650624 00	LABEL	ADESIVO SEGNALETICO	ETIQUETTE	ETKETT

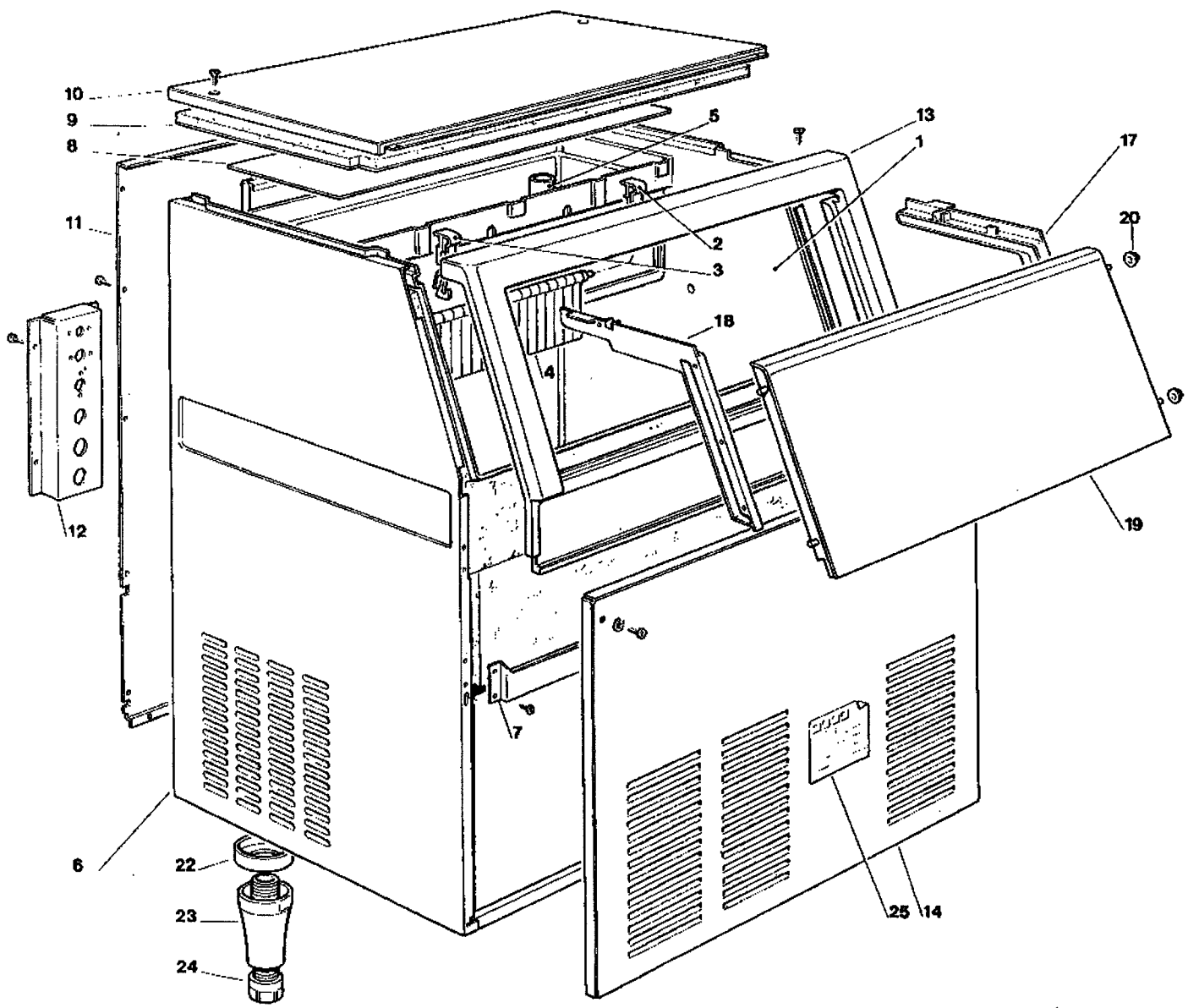

AC 125 C - AC 175 - UNIT PANELS - ASSIEME MOBILE - ENS. CARROSSERIE - MACHINE GEHAUSE

ITEM NO POS NO REP. NO REF. NO	PART NO CODICE REFERENCE STUECK NR	DESCRIPTION	DESCRIZIONE	DESIGNATION	BESCHREIBUNG
1	782081 00 782087 00*	INSULATED STORAGE BIN INSULATED STORAGE BIN	ASSIEME CELLA ISOLATA ASSIEME CELLA ISOLATA	CABINE DE STOCKAGE ISOLEE CABINE DE STOCKAGE ISOLEE	ISOLIEREISSPEICHER ISOLIEREISSPEICHER
2	660388 00	CURTAIN BRACKET RIGHT	SUPPORTO TENDINA DX	SUPPORT RIDEAU DROITE	JALOUSIE RECHTEHALTERUNG
3	660388 01	CURTAIN BRACKET LEFT	SUPPORTO TENDINA SX	SUPPORT RIDEAU GAUCHE	JALOUSIE LINKEHALTERUNG
4	784169 05	CURTAIN	TENDINA	RIDEAU	JALOUSIE
5	281720 04 281720 06*	PLASTIC PIPE PLASTIC PIPE	TUBO IN PLASTICA TUBO IN PLASTICA	TUYAU EN PLASTIQUE TUYAU EN PLASTIQUE	PLASTIKROHR PLASTIKROHR
6	781307 13	UNIT FRAME S.S.	ASSIEME TELAIO ACCIAIO INOX	ENSAMBLE CHASSIS ACIER INOX	EDELSTHAL-CHASSIS REHMEN
7	702127 00	METAL BRACKET	SUPPORTO IN METALLO	SUPPORT METALLIQUE	METALLTRÄGER
8	741075 00	EVAPORATOR COVER	COPERCHIO EVAPORATORE	COUVERCLE ÉVAPORATEUR	VERDAMPFERDECKEL
9	794245 01	UPPER INSULATION	ISOLAMENTO SUPERIORE	ISOLATION SUPERIEUR	OBERE ISOLIERUNG
10	701798 01	TOP PANEL S.S.	PANNELLO SUPERIORE ACC. INOX	PANNEAU SUPERIEURE ACIER INOX	ABDECKEHAUBE EDELSTAHL
11	701928 01	REAR PANEL S.S.	PANNELLO POSTERIORE ACC. INOX	PANNEAU ARRIERE ACIER INOX	REUCKWAND EDELSTAHL
12	701993 01	METAL BRACKET FOR FITTINGS S.S.	SUPPORTO ATTACCHI ACC. INOX	SUPPORT DE RACC. ACIER INOX	ANSCHLUSSTÜCKMETALLTRÄGER EDELSTAHL
13	782078 06 782078 08	BIN DOOR FRAME ASSY - AC 125 BIN DOOR FRAME ASSY - AC 175	ASSIEME CORNICE SPORTELLI - AC 125 ASSIEME CORNICE SPORTELLI - AC 175	ENS. ENCADREMENT PORTE CABINE - AC 125 ENS. ENCADREMENT PORTE CABINE - AC 175	TÜRRAHMEN - AC 125 TÜRRAHMEN - AC 175
14	701796 05	FRONT PANEL S.S.	PANNELLO FRONTALE ACCIAIO INOX	PANNEAU AVANT ACIER INOX	VORDERWAND EDELSTAHL
17	660523 00	RIGHT BIN DOOR GUIDE	GUIDA SPORTELLI DESTRA	GLISSIER DE PORTE DROITE	RECHTESPEICHERTUERGLEIT
18	660523 01	LEFT BIN DOOR GUIDE	GUIDA SPORTELLI SINISTRA	GLISSIER DE PORTE GAUCHE	LINKESPEICHERTUERGLEIT
19	782009 07	BIN DOOR ASSY	ASSIEME SPORTELLI	ENSAMBLE PORTE CABINE	SPEICHERTUER
20	660286 00	DOOR RUNNER - BUSHING	BUSSOLE DI SCORRIMENTO	BAGUE DE COULISSAGE PORTE	TUERGLEITBUCHSE
22	660516 00	LEG SOCKET COLLAR	COPRIGHIERA PIEDINI	COLLIER DE SOCLE PIEDS	FUESSENIPPELNRIING
23	660257 00	LEG	PIEDINO	PIED	FUESSE
24	660258 00	LEG LEVELLER	VITE DI REGOLAZIONE	VIS DE REGLAGE DES PIEDS	NIVELLIERUNGSHUELSE
25	650624 00	LABEL	ADESIVO SEGNALETICO	ETIQUETTE	ETIKETT
		* FROM ACM 125 S.N. 26400 FROM ACM 175 S.N. 2216	* DA ACM 125 N.S. 26400 DA ACM 175 N.S. 2216	* A PARTIR DU ACM 125 N.S. 26400 A PARTIR DU ACM 175 N.S. 2216	* VON ACM 125 S.N. 26400 VON ACM 175 S.N. 2216

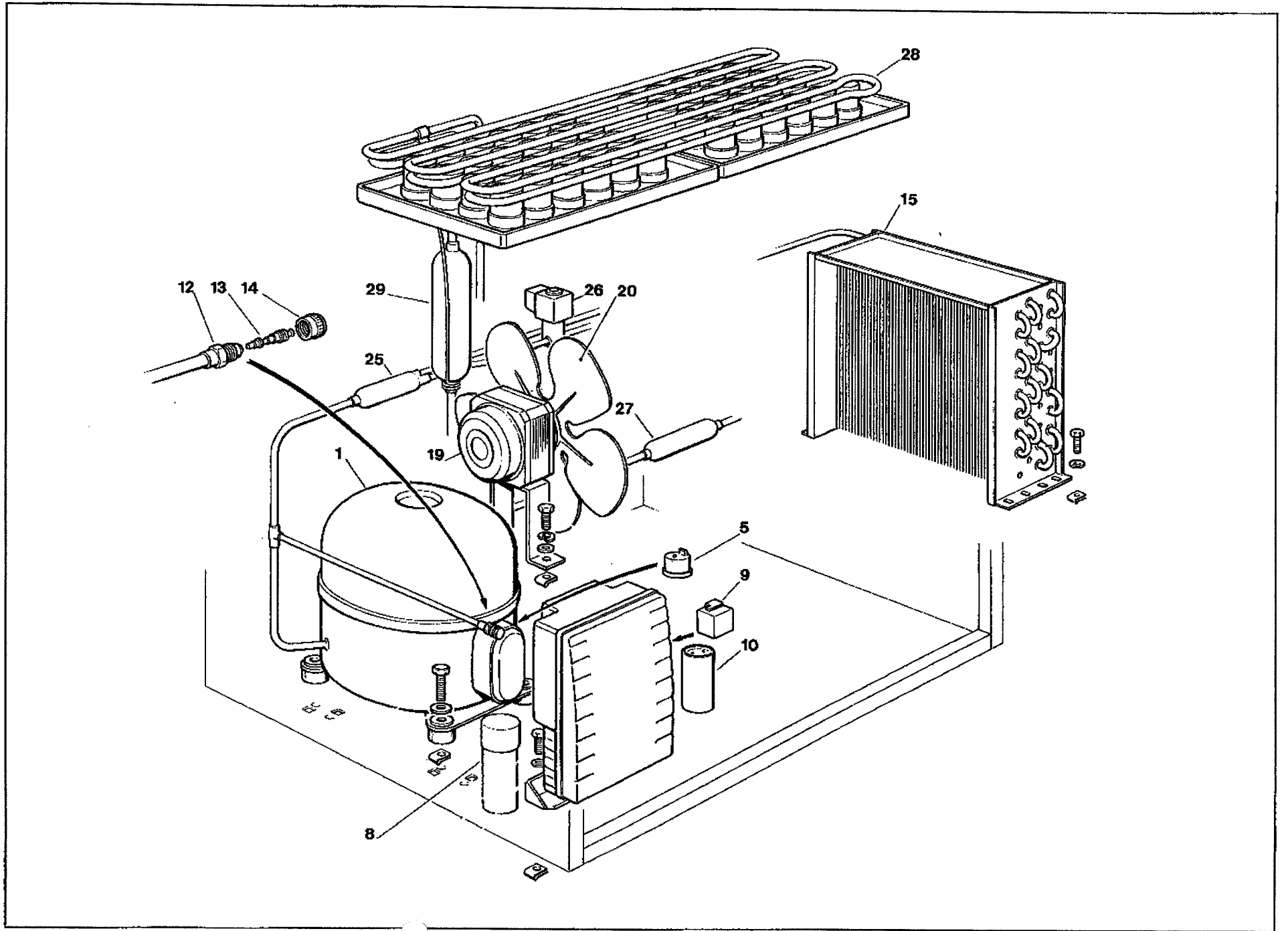

AC 125 - AC 175 - REFRIGERANT SYSTEM AIR COOLED - SISTEMA REFRIGERANTE RAFFR. AD ARIA
CIRCUIT FRIGORIFIQUE REFROID. PAR AIR - LUFTGEKÜHLT GEFRIERSYSTEM

ITEM NO POS NO REP. NO REF. NO	PART NO CODICE REFERENCE STUECK NR	DESCRIPTION	DESCRIZIONE	DESIGNATION	BESCHREIBUNG
1	670000 04 670097 04 670078 23*	COMPRESSOR ASSY - AC 125 COMPRESSOR ASSY - AC 175 COMPRESSOR ASSY - AC 175	ASSIEME COMPRESSORE - AC 125 ASSIEME COMPRESSORE - AC 175 ASSIEME COMPRESSORE - AC 175	ENSAMBLE COMPRESSEUR - AC 125 ENSAMBLE COMPRESSEUR - AC 175 ENSAMBLE COMPRESSEUR - AC 175	KOMPRESSOR - AC 125 KOMPRESSOR - AC 175 KOMPRESSOR - AC 175
5	620058 45 620058 63 620058 75*	PROTECTOR - AC 125 PROTECTOR - AC 175 PROTECTOR - AC 175	PROTETTORE - AC 125 PROTETTORE - AC 175 PROTETTORE - AC 175	PROTECTEUR - AC 125 PROTECTEUR - AC 175 PROTECTEUR - AC 175	SCHUTZGERAT - AC 125 SCHUTZGERAT - AC 175 SCHUTZGERAT - AC 175
8	620167 21 620167 33 620167 21*	RUN CAPACITOR - AC 125 RUN CAPACITOR - AC 175 RUN CAPACITOR - AC 175	CAPACITA DI MARCIA - AC 125 CAPACITA DI MARCIA - AC 175 CAPACITA DI MARCIA - AC 175	CAPACITE PERMANENCE - AC 125 CAPACITE PERMANENCE - AC 175 CAPACITE PERMANENCE - AC 175	BETRIEB KONDENSATOR - AC 125 BETRIEB KONDENSATOR - AC 175 BETRIEB KONDENSATOR - AC 175
9	620168 11 620168 19 620168 11*	START RELAY - AC 125 START RELAY - AC 175 START RELAY - AC 175	RELE DI AVVIAMENTO - AC 125 RELE DI AVVIAMENTO - AC 175 RELE DI AVVIAMENTO - AC 175	RELAIS DE DEMARRAGE - AC 125 RELAIS DE DEMARRAGE - AC 175 RELAIS DE DEMARRAGE - AC 175	RELAIS - AC 125 RELAIS - AC 175 RELAIS - AC 175
10	620167 22 620167 29 620167 43*	START CAPACITOR - AC 125 START CAPACITOR - AC 175 START CAPACITOR - AC 175	CAPACITA D'AVVIAMENTO - AC 125 CAPACITA D'AVVIAMENTO - AC 175 CAPACITA D'AVVIAMENTO - AC 175	CAPACITE DE DEMARRAGE - AC 125 CAPACITE DE DEMARRAGE - AC 175 CAPACITE DE DEMARRAGE - AC 175	START KONDENSATOR - AC 125 START KONDENSATOR - AC 175 START KONDENSATOR - AC 175
12	650109 00	VALVE BODY	CORPO VALVOLA	CORPS DE VANNE	VENTILGEHAUSE
13	670012 00	VALVE PISTON	PISTONCINO VALVOLA	PISTON	VENTILKOLBEN
14	650106 00	VALVE CAP	CAPPUCCIO VALVOLA	CAPUCHON DE VANNE	VENTILKLAPPE
15	620405 00	AIR COOLED CONDENSER	CONDENSATORE AD ARIA	CONDENSEUR A AIR	LUFTGEKÜLTE KONDENSATOR
19	620419 02 620419 04	FAN MOTOR AC 125 FAN MOTOR AC 175	MOTORE VENTILATORE AC 125 MOTORE VENTILATORE AC 175	MOTEUR VENTILATEUR AC 125 MOTEUR VENTILATEUR AC 175	LUFTER MOTOR AC 125 LUFTER MOTOR AC 175
20	620007 07	FAN BLADE	VENTOLA	HELICE	FLUEGEL
25	630020 01	MECHANICAL FILTER	FILTRO MECCANICO	FILTRE MECANIQUE	MECHANISCH FILTERN
26	620306 26 620306 28	HOT GAS VALVE ASSY HOT GAS VALVE COIL	ASSIEME VALVOLA GAS CALDO BOBINA VALVOLA GAS CALDO	ENSAMBLE VANNE GAZ CHAUD BOBINE VANNE GAZ CHAUD	HEISSGAZ VENTIL HEISSGAZ VENTIL SPULE
27	630003 03	DRIER	FILTRO DEUMIDIFICATORE	FILTRE DESHYDRATEUR	TROCKNER
28	784263 00 784263 00	EVAPORATOR ASSY-ACM EVAPORATOR ASSY-ACS	ASSIEME EVAPORATORE-ACM ASSIEME EVAPORATORE-ACS	ENSAMBLE ÉVAPORATEUR-ACM ENSAMBLE ÉVAPORATEUR-ACS	VERDAMPFEREINHEIT-ACM VERDAMPFEREINHEIT-ACS
29	784253 04 784253 06	SUCTION LINE/ACCUMULATOR AC 125 SUCTION LINE/ACCUMULATOR AC 175	ACCUMUL. E LINEA ASPIRAZIONE AC 125 ACCUMUL. E LINEA ASPIRAZIONE AC 175	ENS. ASPIRATION/ACCUMULATEUR AC 125 ENS. ASPIRATION/ACCUMULATEUR AC 175	SAMMLER UND SAUGLEITUNGEN AC 125 SAMMLER UND SAUGLEITUNGEN AC 175
		* FROM S.N. 2016	* DA N.S. 2016	* A PARTIR DU N.S. 2016	* VON S.N. 2016

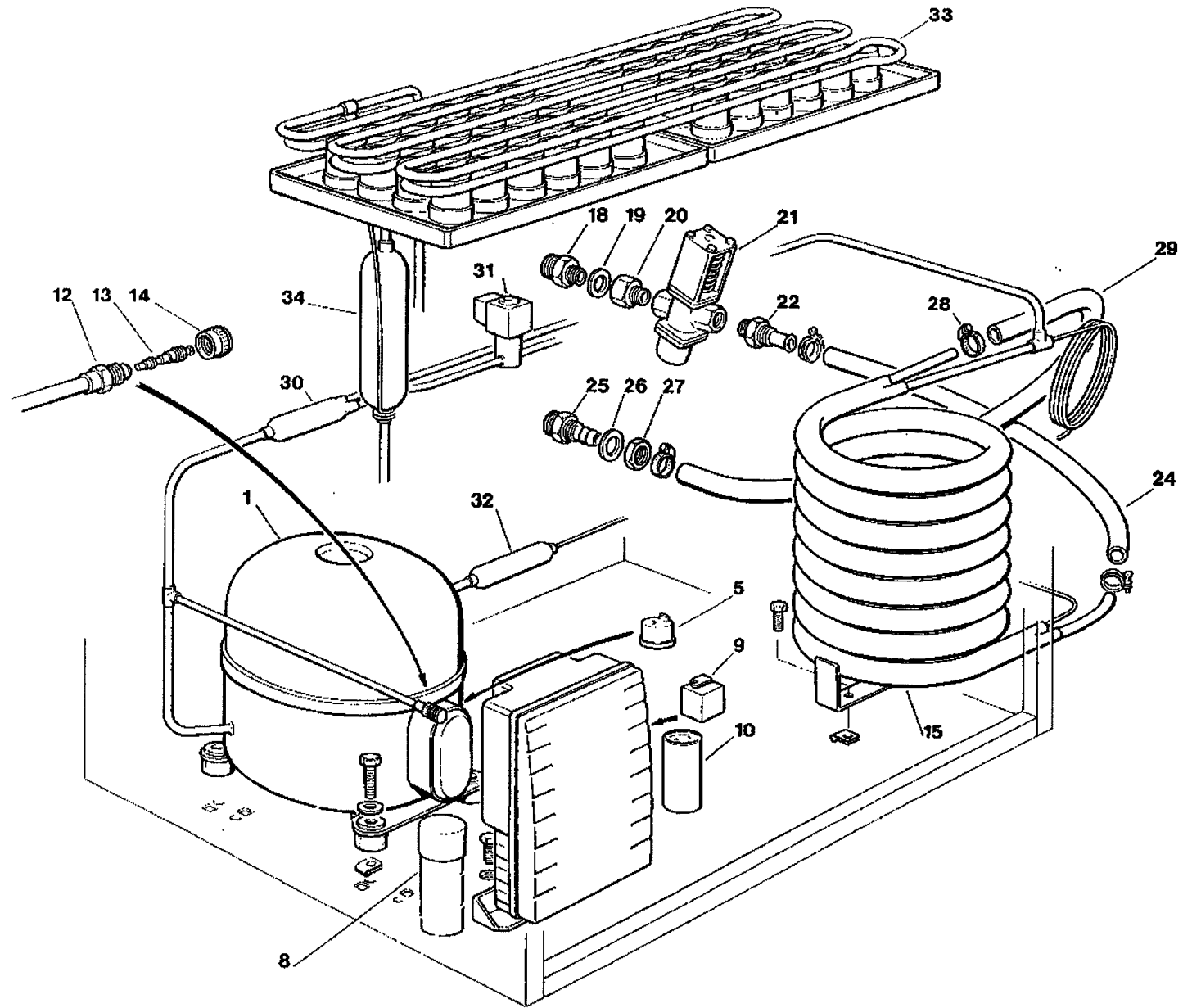

AC 125 - AC 175 - REFRIGERANT SYSTEM WATER COOLED - SISTEMA REFRIGERANTE RAFFR. AD ACQUA
CIRCUIT FRIGORIFIQUE REFROID. PAR EAU - WASSERGEKÜHLT GEFRIERSYSTEM

ITEM NO POS NO REP. NO REF. NO	PART NO CODICE REFERENCE STUECK NR	DESCRIPTION	DESCRIZIONE	DESIGNATION	BESCHREIBUNG
1	670000 04 670097 04 670076 23*	COMPRESSOR ASSY - AC 125 COMPRESSOR ASSY - AC 175 COMPRESSOR ASSY - AC 175	ASSIEME COMPRESSORE - AC 125 ASSIEME COMPRESSORE - AC 175 ASSIEME COMPRESSORE - AC 175	ENSAMBLE COMPRESSEUR - AC 125 ENSAMBLE COMPRESSEUR - AC 175 ENSAMBLE COMPRESSEUR - AC 175	KOMPRESSOR - AC 125 KOMPRESSOR - AC 175 KOMPRESSOR - AC 175
5	620058 45 620058 63 620058 75*	PROTECTOR - AC 125 PROTECTOR - AC 175 PROTECTOR - AC 175	PROTETTORE - AC 125 PROTETTORE - AC 175 PROTETTORE - AC 175	PROTECTEUR - AC 125 PROTECTEUR - AC 175 PROTECTEUR - AC 175	SCHUTZGERAT - AC 125 SCHUTZGERAT - AC 175 SCHUTZGERAT - AC 175
8	620167 21 620167 33 620167 21*	RUN CAPACITOR - AC 125 RUN CAPACITOR - AC 175 RUN CAPACITOR - AC 175	CAPACITA DI MARCIA - AC 125 CAPACITA DI MARCIA - AC 175 CAPACITA DI MARCIA - AC 175	CAPACITE PERMANENCE - AC 125 CAPACITE PERMANENCE - AC 175 CAPACITE PERMANENCE - AC 175	BETRIEB KONDENSATOR - AC 125 BETRIEB KONDENSATOR - AC 175 BETRIEB KONDENSATOR - AC 175
9	620168 11 620168 19 620168 11*	START RELAY - AC 125 START RELAY - AC 175 START RELAY - AC 175	RELE DI AVVIAMENTO - AC 125 RELE DI AVVIAMENTO - AC 175 RELE DI AVVIAMENTO - AC 175	RELAIS DE DEMARRAGE - AC 125 RELAIS DE DEMARRAGE - AC 175 RELAIS DE DEMARRAGE - AC 175	RELAIS - AC 125 RELAIS - AC 175 RELAIS - AC 175
10	620167 22 620167 29 620167 43*	START CAPACITOR - AC 125 START CAPACITOR - AC 175 START CAPACITOR - AC 175	CAPACITA D'AVVIAMENTO - AC 125 CAPACITA D'AVVIAMENTO - AC 175 CAPACITA D'AVVIAMENTO - AC 175	CAPACITE DE DEMARRAGE - AC 125 CAPACITE DE DEMARRAGE - AC 175 CAPACITE DE DEMARRAGE - AC 175	START KONDENSATOR - AC 125 START KONDENSATOR - AC 175 START KONDENSATOR - AC 175
12	650109 00	VALVE BODY	CORPO VALVOLA	CORPS DE VANNE	VENTILGEHAUSE
13	670012 00	VALVE PISTON	PISTONCINO VALVOLA	PISTON	VENTILKOLBEN
14	650106 00	VALVE CAP	CAPPUCCIO VALVOLA	CAPUCHON DE VANNE	VENTILKLAPPE
15	620331 00	WATER COOLED CONDENSER	CONDENSATORE AD ACQUA	CONDENSEUR A EAU	WASSERGEKÜHLT KONDENSATOR
16	400053 00	NUT	DADO	ECROU	MUTTER
19	400052 00	FIBER WASHER	RONDELLA IN FIBRA	RONDELLE EN FIBRE	FIBER SCHEIBE
20	733204 00	WATER INLET FITTING	RACCORDO INGRESSO ACQUA	RACCORD ARRIVÉE D'EAU	WASSER EINLAUFSTÜCK
21	620111 00	WATER REGULATING VALVE	VALVOLA PRESSOSTATICA	VANNE A EAU PRESSOSTATIQUE	WASSERREGLERVENTIL
22	733094 03	REGULATING VALVE OUTLET FITTING	RACCORDO USCITA VALVOLA PRESS.	RACCORD SORTIE VANNE PRESS.	WASSERREGLER ABFLUSSSTUECK
24	281900 01	PLASTIC TUBE-PER METER	TUBO IN PLASTICA-PER METRO	TUYAU EN PLASTIQUE-POUR METRE	PLASTIK ROHR-PRO METER
25	660291 00	WATER DRAIN FITTING	RACCORDO SCARICO ACQUA	RACCORD ÉVACUATION EAU	WASSERABFLUSSSCHLAUCH
26	400031 00	FIBER WASHER	RONDELLA IN FIBRA	RONDELLE EN FIBRE	FIBER SCHEIBE
27	400030 01	NUT	DADO	ECROU	MUTTER
29	281900 01	PLASTIC TUBE-PER METER	TUBO IN PLASTICA-PER METRO	TUYAU EN PLASTIQUE-POUR METRE	PLASTIK ROHR-PRO METER
30	630020 01	MECHANICAL FILTER	FILTRO MECCANICO	FILTRE MECHANIQUE	MECHANISCH FILTERN
31	620306 26 620306 28	HOT GAS VALVE ASSY HOT GAS VALVE COIL	ASS. VALVOLA GAS CALDO BOBINA VALVOLA GAS CALDO	ENS. VANNE GAZ CHAUD BOBINE VANNE GAZ CHAUD	HEISSGAZ VENTIL HEISSGAZ VENTIL SPULE
32	620063 03	DRIER	FILTRO DEUMIDIFICATORE	FILTRE DESHYDRATEUR	TROCKNER
33	784263 00 784263 00	EVAPORATOR ASSY-ACM EVAPORATOR ASSY-ACS	ASSIEME EVAPORATORE-ACM ASSIEME EVAPORATORE-ACS	ENSAMBLE ÉVAPORATEUR-ACM ENSAMBLE ÉVAPORATEUR-ACS	VERDAMPFEREINHEIT-ACM VERDAMPFEREINHEIT-ACS
34	784253 04 784253 06	SUCTION LINE/ACCUMULATOR AC 125 SUCTION LINE/ACCUMULATOR AC 175	ACCUMUL. E LINEA ASPIRAZIONE AC 125 ACCUMUL. E LINEA ASPIRAZIONE AC 175	ENS. ASPIRATION/ACCUMULATEUR AC 125 ENS. ASPIRATION/ACCUMULATEUR AC 175	SAMMLER UND SAUGLEITUNGEN AC 125 SAMMLER UND SAUGLEITUNGEN AC 175
		* FROM S.N. 2016	* DA N.S. 2016	* A PARTIR DU N.S. 2016	* VON S.N. 2016

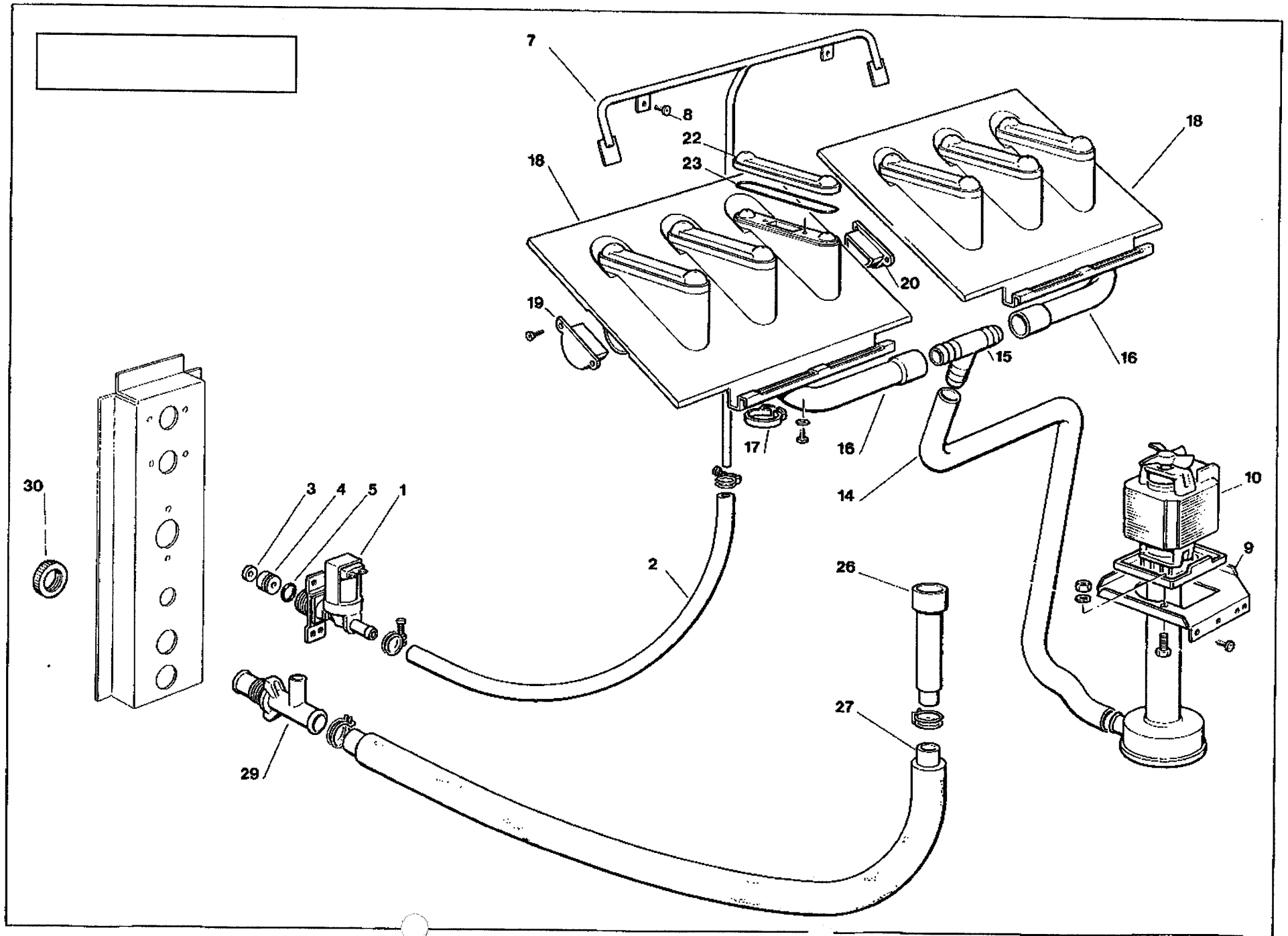

ACM 125 B - WATER SYSTEM - CIRCUITO IDRAULICO - CIRCUIT HYDRAULIQUE - WASSER SYSTEM

ITEM NO POS NO REP. NO REF. NO	PART NO CODICE REFERENCE STUECK NR	DESCRIPTION	DESCRIZIONE	DESIGNATION	BESCHREIBUNG
1	650105 00	WATER INLET VALVE	VALVOLA INGRESSO ACQUA	VANNE ARRIVÉE D'EAU	WASSEREINLAUFVENTIL
2	291900 01	WATER INLET TUBE-PER METER	TUBO INGRESSO ACQUA-PER METRO	TUYAU ARRIVÉE D'EAU-POUR METRE	WASSEREINLAUFROHR-PRO METER
3	640022 00	FLOW CONTROL	CONTROLLO DI FLUSSO	CONTRÔLE DE DEBIT	DURCHFLUSSREGLER
4	733185 00	FLOW CONTROL BODY	CORPO CONTROLLO DI FLUSSO	CORPS CONTRÔLE DE DEBIT	DURCHFLUSSREGLER GEHAUSE
5	640110 00	O RING	GUARNIZIONE OR	JOINT TORIQUE	SIMMER RING
7	660537 00	WATER DISTRIBUTOR TUBE	TUBO DISTRIBUTORE D'ACQUA	TUYAU DISTRIBUTEUR EAU	WASSERVERTEILERROHR
9	723079 00	PUMP MOTOR BRACKET	SUPPORTO POMPA	SUPPORT METALLIQUE POMPE	PUMPENTRÄGER
10	793113 03	WATER PUMP ASSY	ASSIEME POMPA	ENSAMBLE POMPE A EAU	WASSER PUMPE
14	610155 00	WATER TUBE - PUMP TO SPRAY SYSTEM	TUBO MANDATA POMPA	TUYAU - POMPE PLAQUE D'ARROSAGE	SCHLAUCH PUMPE - SPRUHSYSTEM
15	610053 02	T FITTING	RACCORDO A T	RACCORD A T	T STÜCK
16	610156 00	TUBE - T SPRAY SYSTEM	TUBO - T PIASTRA SPRUZZANTE	TUYAU - T PLAQUE D'ARROSAGE	ROHR - T SPRUHSYSTEM
17	660499 01	PLASTIC CLAMP	FASCETTA IN PLASTICA	COLLIER EN PLASTIQUE	PLASTIK SCHELLE
18	793129 01	SPRAY PLATEN ASSY	ASSIEME PIASTRA SPRUZZANTE	ENS. PLAQUE PULVERISATION EAU	SPRUHSYSTEM EINHEIT
19	660520 03	PLASTIC PLUG	TAPPO IN PLASTICA	BOUCHON EN PLASTIQUE	PLASTIK VERSTOPFEN
20	660520 02	PLASTIC PLUG	TAPPO IN PLASTICA	BOUCHON EN PLASTIQUE	PLASTIK VERSTOPFEN
22	660519 01	PLASTIC COVER	COPERCHIO IN PLASTICA	COUVERCLE EN PLASTIQUE	PLASTIK DECKEL
23	640041 20	O RING	GUARNIZIONE OR	JOINT TORIQUE	SIMMER RING
26	660387 00	OVERFLOW STAND PIPE	TUBO TROPPO PIENO	TUYAU TROP PLEIN	UEBERLAUFROHR
27	610146 07	WATER DRAIN TUBE	TUBO SCARICO ACQUA	TUYAU ÉVACUATION EAU	ABFLUSSROHR
29	660224 00	DRAIN T FITTING	RACCORDO DI SCARICO	RACCORD T D'ÉVACUATION	T STÜCK
30	660535 00	PLASTIC RING NUT	GHIERA IN PLASTICA	COLLIER DE SERRAGE EN PLASTIQUE	PLASTICK RING MUTTER

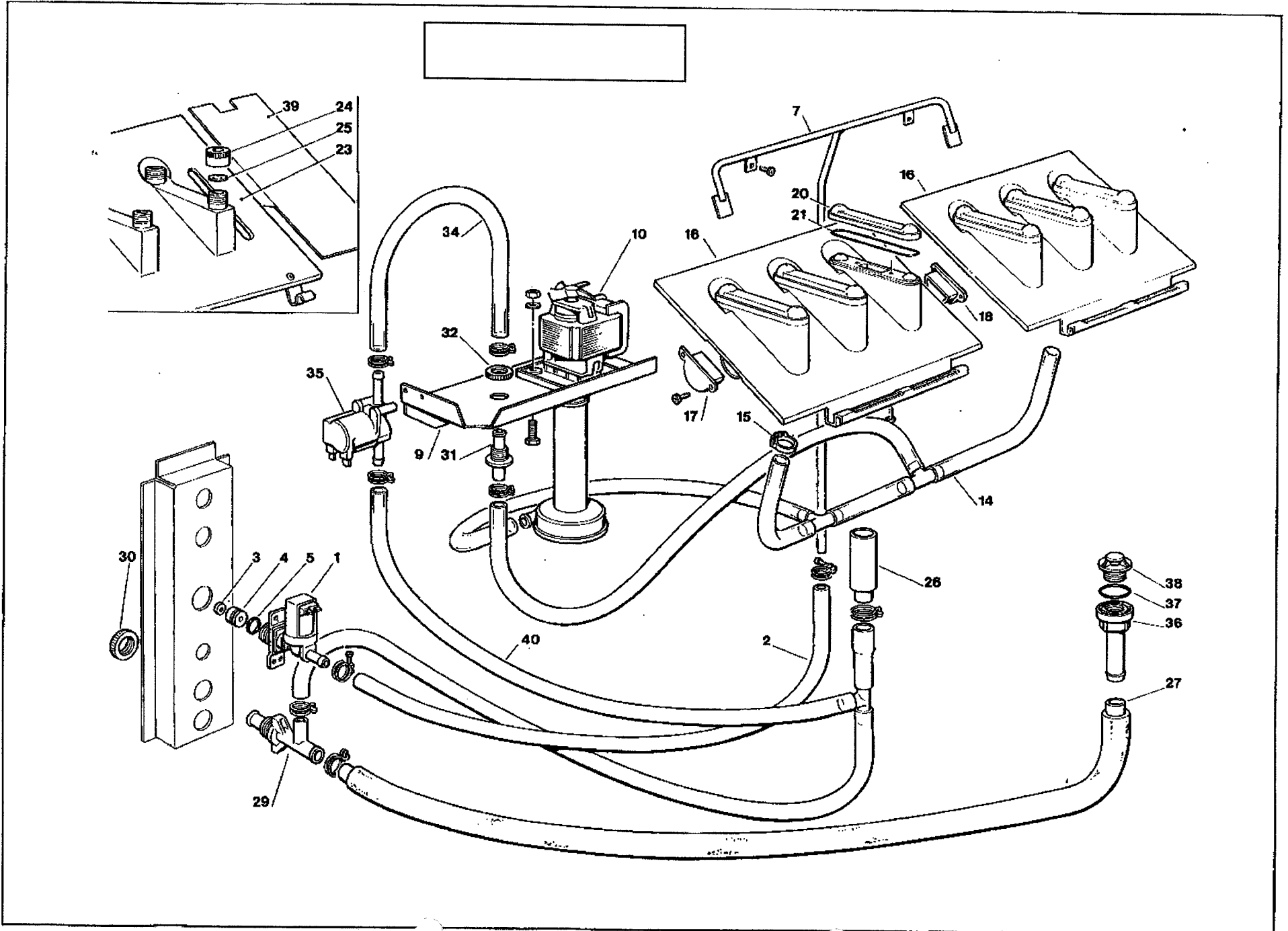

AC 125 - AC 175 - WATER SYSTEM - CIRCUITO IDRAULICO - CIRCUIT HYDRAULIQUE - WASSERSYSTEM

ITEM NO POS NO REP. NO REF. NO	PART NO CODICE REFERENCE STUECK NR	DESCRIPTION	DESCRIZIONE	DESIGNATION	BESCHREIBUNG
1	650105 00	WATER INLET VALVE	VALVOLA INGRESSO ACQUA	VANNE ARRIVÉE D'EAU	WASSEREINLAUFVENTIL
2	291900 01	WATER INLET TUBE-PER METER	TUBO INGRESSO ACQUA-PER METRO	TUYAU ARRIVÉE D'EAU-POUR METRE	WASSEREINLAUFROHR-PRO METER
3	640022 00	FLOW CONTROL	CONTROLLO DI FLUSSO	CONTRÔLE DE DEBIT	DURCHFLOSSREGLER
4	733185 00	FLOW CONTROL BODY	CORPO CONTROLLO DI FLUSSO	CORPS CONTRÔLE DE DEBIT	DURCHFLOSSREGLER GEHAUSE
5	640110 00	O RING	GUARNIZIONE OR	JOINT TORIQUE	SIMMER RING
7	660537 00	WATER DISTRIBUTOR TUBE	TUBO DISTRIBUTORE D'ACQUA	TUYAU DISTRIBUTEUR EAU	WASSERVERTEILERROHR
9	723147 00 723156 00*	PUMP MOTOR BRACKET PUMP MOTOR BRACKET	SUPPORTO POMPA SUPPORTO POMPA	SUPPORT METALLIQUE POMPE SUPPORT METALLIQUE POMPE	PUMPENTRÄGER PUMPENTRÄGER
10	793113 12 793146 03*	WATER PUMP ASSY WATER PUMP ASSY	ASSIEME POMPA ASSIEME POMPA	ENSAMBLE POMPE A EAU ENSAMBLE POMPE A EAU	WASSER PUMPE WASSER PUMPE
14	610175 00 610186 00*	WATER TUBE - PUMP TO SPRAY SYSTEM WATER TUBE - PUMP TO SPRAY SYSTEM	TUBO MANDATA POMPA TUBO MANDATA POMPA	TUYAU - POMPE PLAQUE D'ARROSAGE TUYAU - POMPE PLAQUE D'ARROSAGE	SCHLAUCH PUMPE - SPRUHSYSTEM SCHLAUCH PUMPE - SPRUHSYSTEM
15	650499 01	PLASTIC CLAMP	FASCETTA IN PLASTICA	COLLIER EN PLASTIQUE	PLASTIK SCHELLE
16	793129 01	SPRAY PLATEN ASSY-ACM	ASSIEME PIASTRA SPRUZZANTE-ACM	ENS. PLAQUE PULVERISATION EAU-ACM	SPRUHSYSTEM EINHEIT-ACM
17	660520 03	PLASTIC PLUG	TAPPO IN PLASTICA	BOUCHON EN PLASTIQUE	PLASTIK VERSTOPFEN
18	660520 02	PLASTIC PLUG	TAPPO IN PLASTICA	BOUCHON EN PLASTIQUE	PLASTIK VERSTOPFEN
20	660519 01	PLASTIC COVER	COPERCHIO IN PLASTICA	COUVERCLE EN PLASTIQUE	PLASTIK DECKEL
21	640041 20	O RING	GUARNIZIONE OR	JOINT TORIQUE	SIMMER RING
23	793117 00	SPRAY PLATEN ASSY-ACS	ASSIEME PIASTRA SPRUZZANTE	ENS. PLAQUE PULVERISATION EAU	SPRUHSYSTEM EINHEIT
24	660155 03	SPRAY JET	CAPPUCCIO SPRUZZATORE	CAPUCHON	SPRUHKOPF
25	660296 02	SPINNER JET	RONDELLA SPRUZZANTE	GICLEUR	SPRYTZ VORRICHTUNG
26	281720 04 281720 06*	OVERFLOW STAND PIPE OVERFLOW STAND PIPE	TUBO TROPPO PIENO TUBO TROPPO PIENO	TUYAU TROP PLEIN TUYAU TROP PLEIN	UEBERLAUFROHR UEBERLAUFROHR
27	610148 15	WATER DRAIN TUBE	TUBO SCARICO ACQUA	TUYAU ÉVACUATION EAU	ABFLUSSROHR
29	660224 00	DRAIN T FITTING	RACCORDO DI SCARICO	RACCORD T D'ÉVACUATION	T STÜCK
30	660535 00	PLASTIC RING NUT	GHIERA IN PLASTICA	COLLIER DE SERRAGE EN PLASTIQUE	PLASTICK RING MUTTER
31	660534 00	PLASTIC FITTING	RACCORDO DI SCARICO	RACCORD ÉVACUATION	ABFLUSS STÜCK
32	660535 00	PLASTIC RING NUT	GHIERA IN PLASTICA	COLLIER DE SERRAGE EN PLASTIQUE	PLASTIKRING MUTTER
34	610173 00	TUBE	TUBO	TUYAU	ROHR
35	620406 00	WATER DRAIN VALVE	VALVOLA SCARICO ACQUA	VANNE VIDANGE EAU	WASSERABFLUSSVENTIL
36	660219 01	DRAIN FITTING	RACCORDO DI SCARICO	RACCORD ÉVACUATION	ABFLUSSROHR
37	640134 00	O RING	GUARNIZIONE O R	JOINT TORIQUE	SIMMER RING
38	660211 01	DRAIN FILTER	FILTRO SCARICO ACQUA	FILTRE ÉVACUATION EAU	ABFLUSSFILTER
39	723105 00	S.S. PLATE	PIASTRINA IN ACC. INOX	PLAQUE EN ACIER INOX	EDELSTAHLPLATTE
40	610176 01	TUBE	TUBO	TUYAU	ROHR
		* FROM ACM 125 S.N. 26400 FROM ACM 175 S.N. 2216	* DA ACM 125 N.S. 26400 DA ACM 175 N.S. 2216	* A PARTIR DU ACM 125 N.S. 26400 A PARTIR DU ACM 175 N.S. 2216	* VON ACM 125 S.N. 26400 VON ACM 175 S.N. 2216

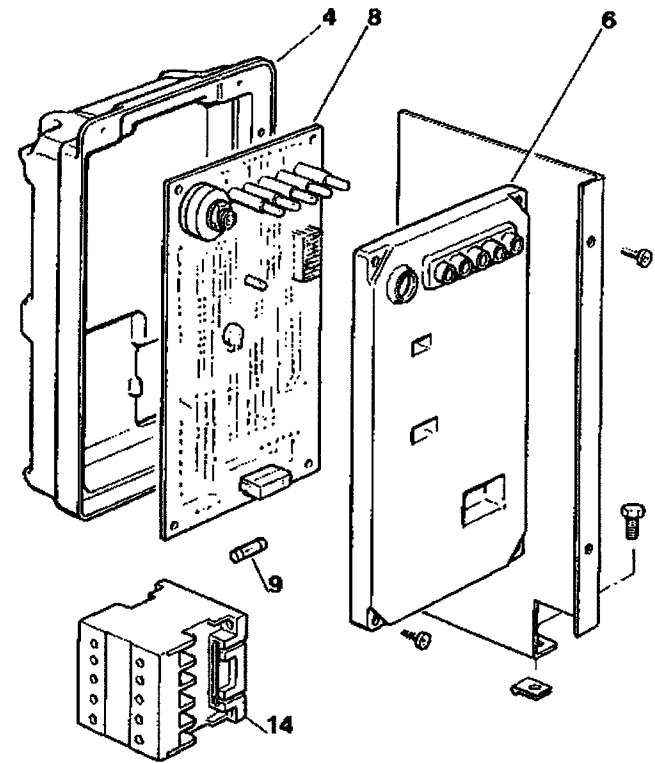
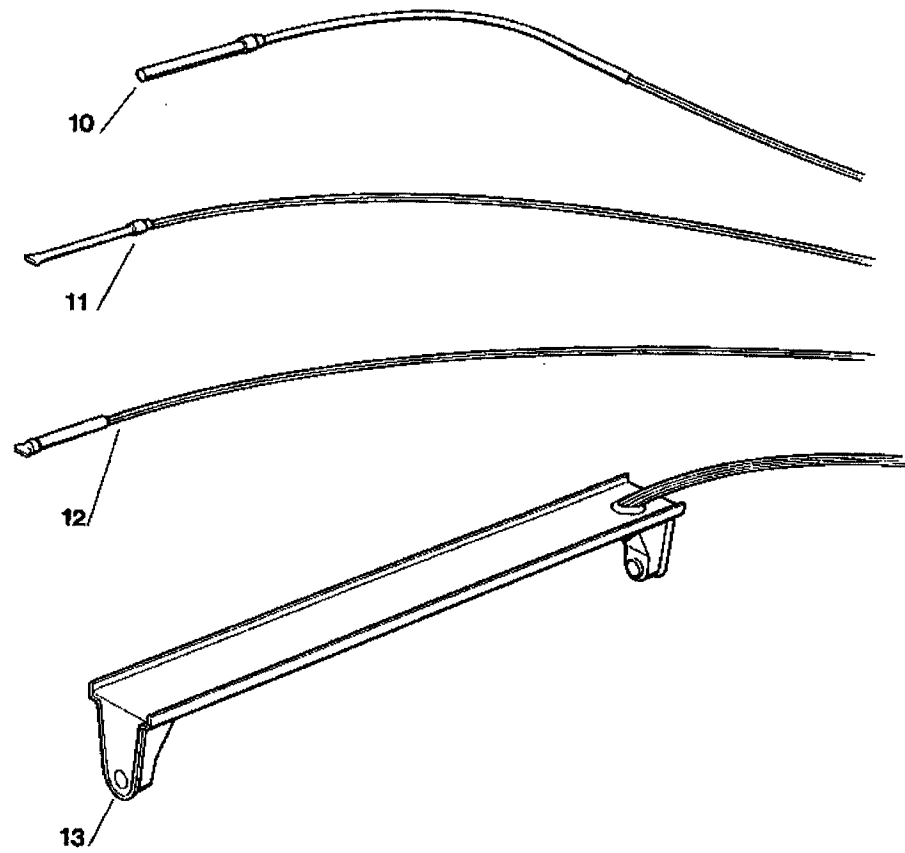

AC 125 - AC 175 - P.C. BOARD AND SENSOR ASSY - SCHEDA ELETTRONICA E SENSORI -ENS. CARTE ELECTRIQUE ET DETECTEURS
 ELEKTRONISCHE KARTE UND TEMPERATURFUEHLERENHEIT

ITEM NO POS NO REP. NO REF. NO	PART NO CODICE REFERENCE STUECK NR	DESCRIPTION	DESCRIZIONE	DESIGNATION	BESCHREIBUNG
4	660546 00	CONTROL BOX	SCATOLA ELETTRICA	BOITE ELECTRIQUE	SCHALT SCHRANK
6	PA8069 00	CONTROL BOX COVER	COPERCHIO SCATOLA ELETTRICA	COUVERCLE BOITE DE COMMANDE	SCHALTSCHRANK DECKEL
8	620403 01	P. C. BOARD ASSY	ASSIEME SCHEDA ELETTRONICA	ENSAMBLE CARTE ELECTRONIQUE	GEDRUCKTESCHALTUNG
9	630015 09 630015 10	FUSE (100 mA) FUSE (16 A)	FUSIBILE (100 mA) FUSIBILE (16 A)	FUSIBLE (100 mA) FUSIBLE (16 A)	SCHMELZSICHERUNG (100 mA) SCHMELZSICHERUNG (16 A)
10	620404 10	EVAPORATOR TEMP. SENSOR	SENSORE TEMP. EVAPORATORE	CAPTEUR TEMP. ÉVAPORATEUR	VERDAMPFERTEMPERATURFUEHLER
11	620404 01	CONDENSER TEMP. SENSOR	SENSORE TEMP. CONDENSATORE	CAPTEUR TEMP. CONDENSEUR	KONDENSATORTEMPERATURFUEHLER
12	620404 02	AMBIENT TEMP. SENSOR	SENSORE TEMP. AMBIENTE	CAPTEUR TEMP. AMBIANCE	RAUMTEMPERATURFUEHLER
13	650674 00	ICE LEVEL CONTROL ASSY	ASS. CONTR. LIVELLO GHIACCIO	ENS. DETECTEUR NIVEAU GLACE	EISNIVEAUFUEHLEREINHEIT
14	630119 02	CONTACTOR	TELERUTTORE	CONTACTEUR	SCHALTSCHÜTZ

AC 125 - AC 175 - COMPRESSOR CHART - TABELLA COMPRESSORI - TABLEAU COMPRESSEUR - KOMPRESSOR KARTE

MODEL MODELLO MODELE MODELL	VOLTS TENSIONE TENSION SPANNUNG	COMPRESSOR MODEL MOD. COMPRESSORE TYPE COMPRESSEUR KOMPRESSOR TYP	COMPRESSOR COMPRESSORE COMPRESSEUR KOMPRESSOR	RELAY RELE RELAIS RELAIS	PROTECTOR PROTETTORE PROTECTEUR SCHUTZGERAT	START CAPACITOR CAPACITA D'AVV. CAPACITE DE DEMARRAGE START KONDENSATOR	RUN CAPACITOR CAPACITA DI MARCIA CAPACITE PERMANENCE BETRIEB KONDENSATOR
ACM 125	115/60/1	U.H. CAE 9460 T	670000 08	620168 23	620058 72	620167 41	620167 22
ACM 125 ACM 175 ACM 175*	230/60/1 230/60/1 230/60/1	U.H. AE 5465 E ELECTROLUX S 18 TN U.H. AJ 5510 F	670000 06 670097 05 670076 24	620168 14 620057 38 620168 14	620058 51 620058 68 620058 75	620167 22 620167 29 620167 22	620167 21 620167 36 620167 21
ACM 125 ACM 175 ACM 175*	220/50/1 220/50/1 220/50/1	U.H. AE 5465 E ELECTROLUX S 18 TN U.H. AJ 5510 F	670000 04 670097 04 670076 23	620168 11 620168 19 620168 11	620058 45 620058 63 620058 75	620167 22 620167 29 620167 22	620167 21 620167 33 620167 21

* FROM ACM 175 S.N. 2016

* DA ACM 175 N.S. 2016

* A PARTIR DU ACM 175 N.S. 2016

* VON ACM 175 S.N. 2016

AC 125 - AC 175 - ELECTRIC COMPONENTS CHART - TABELLA COMPONENTI ELETTRICI
TABLEAU COMPOSANTS ELECTRIQUE - ELEKTRISCHEKARTE

MODEL MODELLO MODELE MODELL	VOLTS TENSIONE TENSION SPANNUNG	CONTACTOR TELERUTTORE CONTACTEUR SCHALTSCHÖTZ	WATER PUMP POMPA POMPE A EAU WASSER PUMPE	FAN MOTOR ONLY MOTORE VENTILATORE MOTEUR VENTILATEUR LUFTER MOTOR	WATER INLET VALVE VALV. INGR. ACQUA V.E.M. ARRIVEE EAU WASSEREIN.VENTIL	HOT GAS VALVE COIL BOBINA VALVOLA GAS CALDO BOBINE V.E.M. GAZ CHAUDS HEISSGAZ VENTIL SPULE	P.C. BOARD SCHEDA ELETTRONICA CARTE ELECTRONIQUE ELEKTRONISCHE KARTE
ACM 125 B ACM 125 C ACM 125 C*	115/60/1 115/60/1 115/60/1	630124 07 630124 07 630124 07	793113 04 793113 13 793146 04	620419 03 620419 03 620419 03	650105 01 650105 01 650105 01	620306 17 620306 17 620306 17	620403 13 620403 13 620403 13
ACM 125 B ACM 125 C ACM 125 C* ACM 175 ACM 175*	230/60/1 230/60/1 230/60/1 230/60/1 230/60/1	630119 02 630119 02 630119 02 630119 02 630119 02	793113 05 793113 14 793146 05 793113 14 793146 05	620419 02 620419 02 620419 02 620419 04 620419 04	650105 00 650105 00 650105 00 650105 00 650105 00	620306 28 620306 28 620306 28 620306 28 620306 28	620403 12 620403 12 620403 12 620403 12 620403 12
ACM 125 B ACM 125 C ACM 125 C* ACM 175 ACM 175*	220/50/1 220/50/1 220/50/1 220/50/1 220/50/1	630119 02 630119 02 630119 02 630119 02 630119 02	793113 03 793113 12 793146 03 793113 12 793146 03	620419 02 620419 02 620419 02 620419 04 620419 04	650105 00 650105 00 650105 00 650105 00 650105 00	620306 28 620306 28 620306 28 620306 28 620306 28	620403 12 620403 12 620403 12 620403 12 620403 12

* FROM ACM 125 S.N. 26400
FROM ACM 175 S.N. 2216

* DA ACM 125 N.S. 26400
DA ACM 175 N.S. 2216

* A PARTIR DU ACM 125 N.S. 26400
A PARTIR DU ACM 175 N.S. 2216

* VON ACM 125 S.N. 26400
VON ACM 175 S.N. 2216