

FME-10 FME-2/10 FME-15 FME-2/15

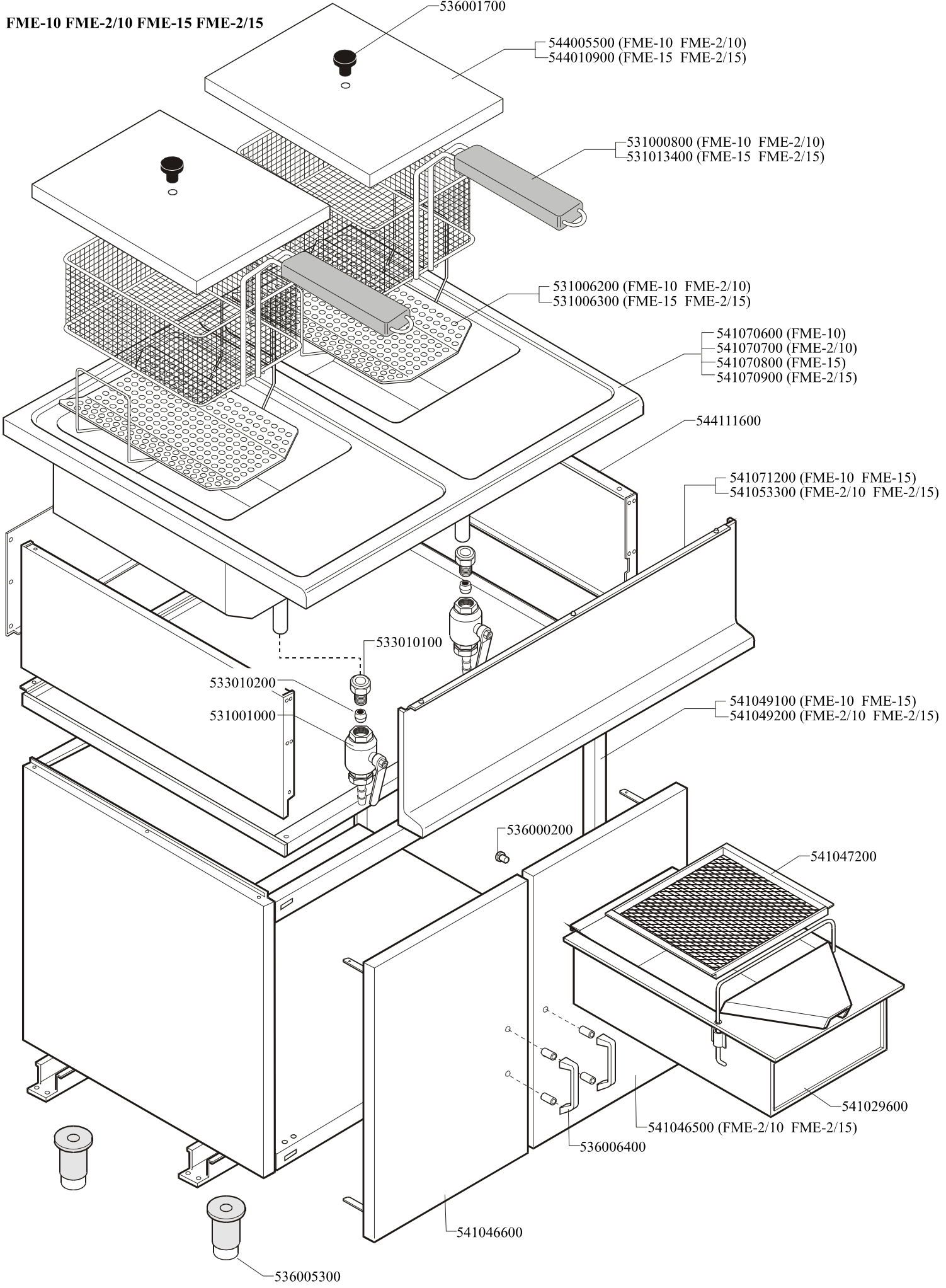

FME-10 FME-2/10 FME-15 FME-2/15

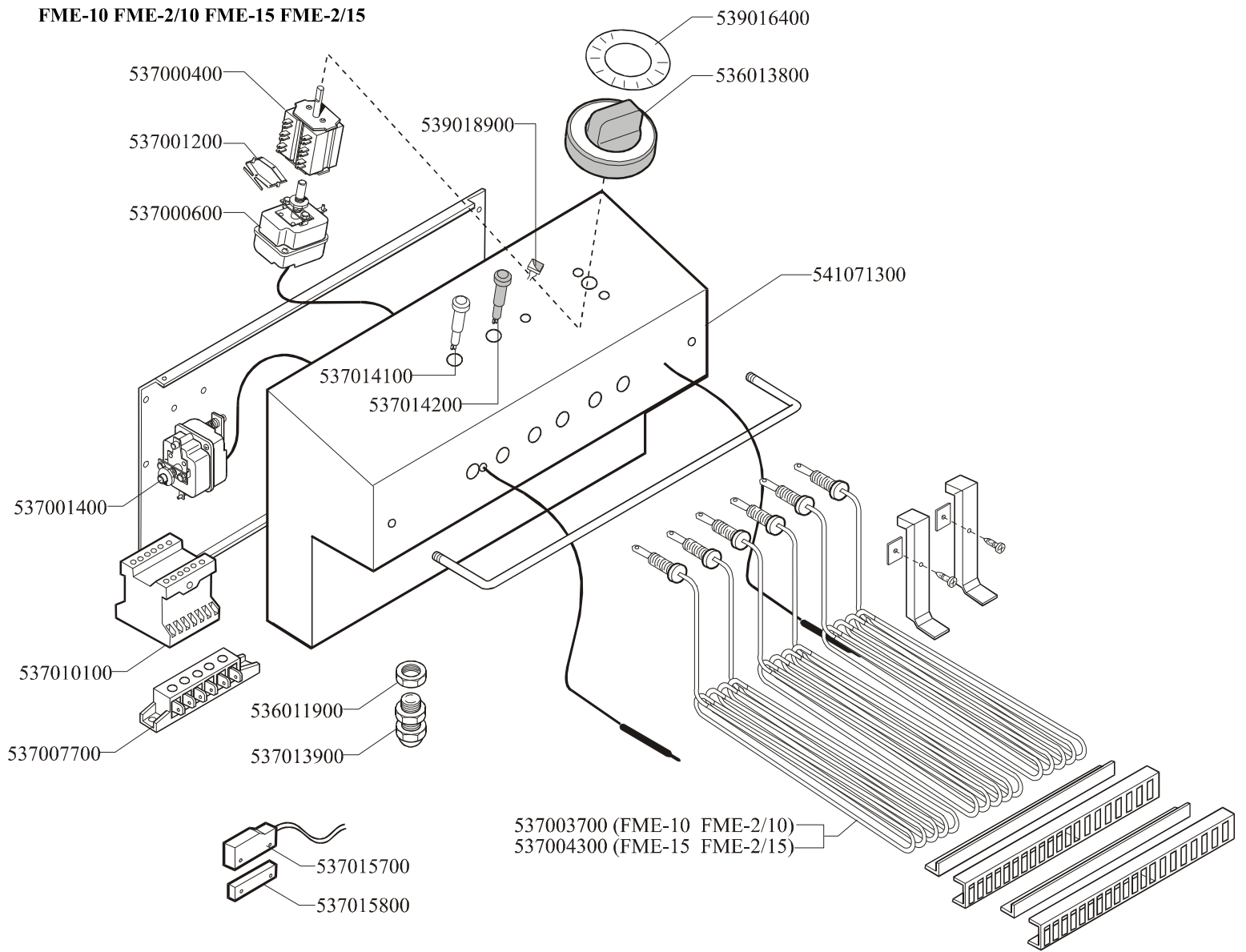

Page	Pos	Code	Description
001		536001700	GRIP D.25*19*M6
001		544010900	TANK LID FME-15
001		531013400	FRYER BASKET 15LTS.GAS/ELECTRIC
001		531006300	FILTER FME-15
001		541070900	UPPER PLATE FME-2/15
001		544111600	SIDE PANEL 700
001		541053300	CONTROL PANEL FMPE-25 FME-2/10/15
001		533010100	3/4 D. 18 PIPE UNION
001		533010200	BICONE 18S
001		531001000	DRAIN COCK 3/4" + HANDLE
001		541049200	800 CABINET
001		536000200	D.12 H.4 BUMPER
001		541047200	FILTER FOR DRIP TRAY
001		541029600	DRIP TRAY 40L
001		541046500	RIGHT DOOR 40
001		536006400	BLACK HANDLE 65/FE/FG
001		541046600	LEFT DOOR 40
001		536005300	PLASTIC LED 2"
002		539016400	ADHESIVE GRADUATED DISC FOR KNOB
002		536013800	KNOB D.70 BLACK 6*5 WITH SPRING
002		539018900	INDEX FOR KNOB
002		537000400	COMMUTATOR 1POS.SINGLEPHASE S49 16A
002		537001200	FIXING BRACKET FOR THERMOSTAT/COMM.
002		537000600	THERMOSTAT 90-180°C SINGLEPHASE
002		541071300	CONTROL BOX FE-10 FME-15
002		537014100	WHITE WARNING LIGHT 250V
002		537014200	GREEN WARNING LIGHT 250V
002		537001400	SAFETY THERMOSTAT 235°C THREEPHASE
002		537004300	HEATING ELEMENT W3000 V230 FME-15
002		537015700	MAGNETIC SENSOR (SWITCH)
002		537015800	MAGNETIC UNIT FOR SENSOR
002		536011900	HEXAGONAL LOCK NUT PG-16
002		537013900	CABLE SECURING CLAMP PG-16
002		537007700	TERMINAL BLOCK THREEPHASE 40A
002		537010100	REMOTE CONTROL SWITCH 20A 230V