



MÁQ. DE LAVAR LOUÇA



MÁQUINA LAVAR F 532 TR - 6.0.095.0057

POTÊNCIA 5300 W
POWER

TENSÃO DE ALIMENTAÇÃO 400V-3N/50Hz
POWER SUPPLY

CAPACIDADE DA CUBA 35 Lt / 4500W
TANK CAPACITY

CAPACIDADE DA CALDEIRA 5 Lt / 4500W
BOILER CAPACITY

ALTURA DE ENTRADA 335 mm
WORKING HEIGHT

PRODUTIVIDADE 30 cestos/h
PRODUCTIVITY

CONSUMO DE ÁGUA/CICLO 2,5 Lt
WATER CONSUMPTION

PESO LIQUIDO 60 kg
NET WEIGHT

PESO BRUTO 70 kg
GROSS WEIGHT

DIMENSÕES (LxPxH) 600x630x815 mm
DIMENSIONS (LxPxH)

DIMENSÕES DA EMBALAGEM (LxPxH) 700x700x900 mm
PACKAGE DIMENSIONS

DIMENSÕES DO CESTO (LxP) 500x500 mm
BASKET DIMENSIONS

MÁQUINA LAVAR F 532 TR

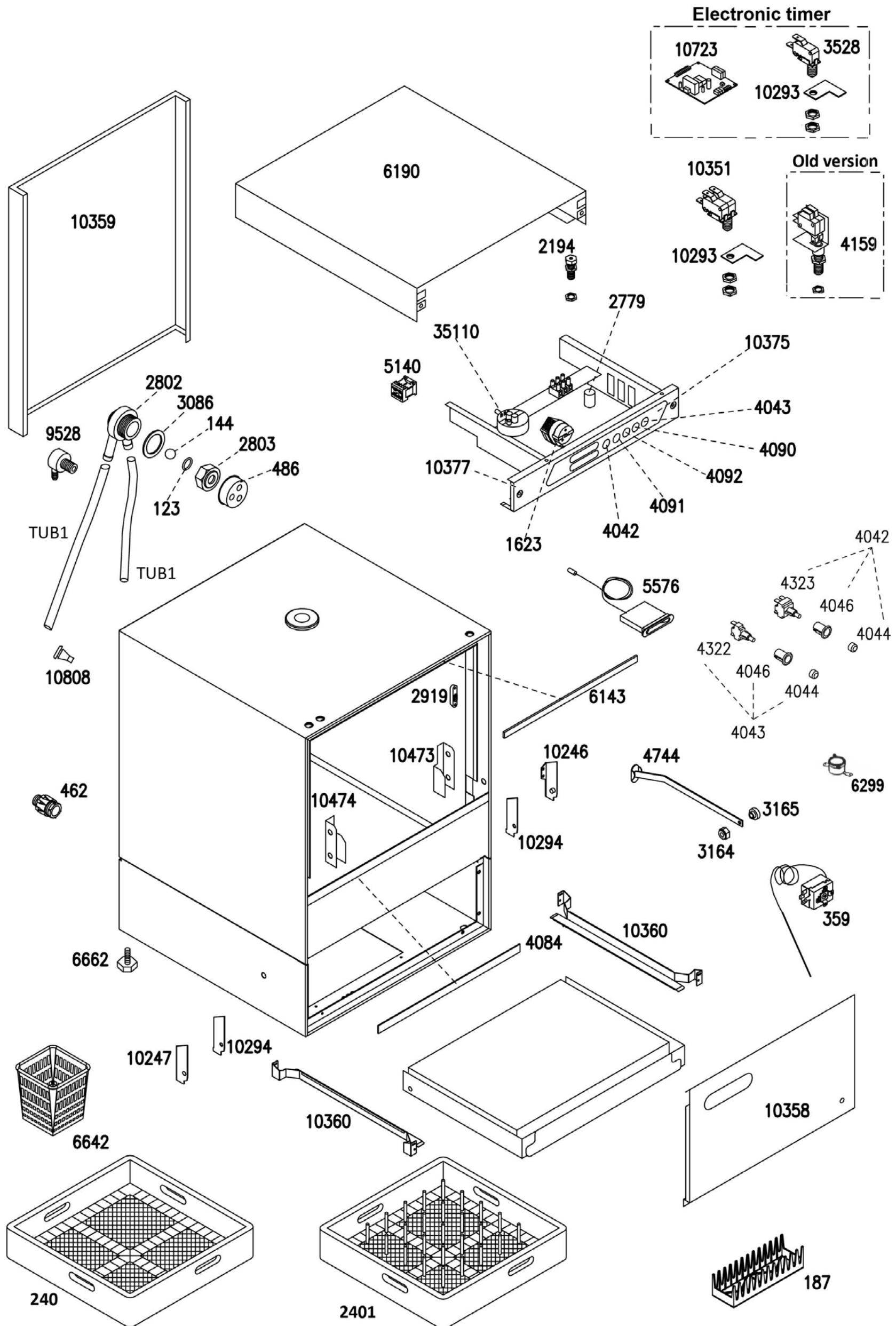

MÁQUINA LAVAR F 532 TR

LISTA DE COMPONENTES E ACESSÓRIOS

Spare parts list

ITEM Nº	CODIGO	DESIGNAÇÃO	DESIGNATION
25	5.0.097.0025	ORING 20,63X2,62	O'RING OR 128
32	5.0.097.0032	CURVA ESGOTO Ø35	DRAIN TUBE
43	5.0.097.0043	FILTRO CUBA F430/F532/F1040	INOX ROUND FILTER
57	5.0.097.0057	JUNTA RESISTENCIA CALDEIRA	BOILER HEATING ELEMENT GASKET
60	5.0.097.0060	BOMBA ABRILHANTADORA	BRIGHTENER DISPENSER
93	5.0.097.0093	ORING BRAÇO LAVAGEM	O'RING OR 121
123	5.0.097.0123	ORING VALVULA DVGW	O'RING OR 11,91X2,62
135	4.0.000.0850	TUBO TEFLON Ø6X1MM	TUBE 4X6MM
139	5.0.097.0139	TUBO ENTRADA AGUA	WATER INLET TUBE
144	5.0.097.0144	ESFERA 5/8 PTFE VALVULA DVGW	5/8 PTFE BALL
187	5.0.097.0187	PORTA PIRES - 15	DISH HOLDER FOR BASKET
203	5.0.097.0203	PORCA CURVA ESGOTO Ø35	FASTENING NUT
204	5.0.097.0204	JUNTA 59X45X2,5 (CURVA ESGOTO Ø35)	RUBBER GASKET
240	5.0.097.0240	CESTO COPOS 500X500	GLASS BASKET 500X500
267	5.0.097.0267	PORCA RESISTENCIA CUBA	HEATING ELEMENT NUT
359	5.0.097.0359	TERMOSTATO REGULAVEL 0-90°C	THERMOSTAT 0° TO 90° C1200
394	5.0.097.0394	ELECTROVALVULA SIMPLES 90° FINA	ELECTROVALVE 90°
462		CERRA CABOS PG21	CABLES FASTENER WITH NUT ART106/21 PG21
486	5.0.097.0486	TAMPA VALVULA DVGW	COVER FOR THE ANTI-FLOW VALVE
697	5.0.097.0697	ORING RESISTENCIA CUBA OR112	HEATING ELEMENT O'RING
1173	5.0.097.1173	ANILHA TEFLON 16X10X2	16X10X2MM TEFLON WASHER
1299	5.0.097.1299	RESISTENCIA CALDEIRA 4500W F532/F1040	BOILER HEATING ELEMENT 4500W
1350	5.0.097.1350	RESISTENCIA CUBA 4500W F532/F1040	TANK HEATING ELEMENT 4500W
1623	5.0.097.1623	TEMPORIZADOR 2 MIN.	TIMER
1633	5.0.097.1633	ORING CONCHA DISTRIBUIDORA	SHELL O'RING
1678	4.0.065.0056	CABO H07RN-F 3G4	H07RN-F 3G4 CABLE
1954	5.0.097.1954	DISTRIBUIDOR BRAÇO 4 VIAS	4RP DISTRIBUTOR
2036		CONDENSADOR 16	CONDENSATOR 16
2149	5.0.097.2149	DISTRIBUIDOR 3 VIAS	LOWER SHELL
2153	5.0.097.2153	VEIO HASTE INFERIOR	SHAFT FOR LOWER HAND
2188	5.0.097.2188	TUBO SAIDA AGUA F430/F532/F1040	DRAIN TUBE
2194	5.0.097.2194	FECHO DA PORTA	DOOR LOCK ASSEMBLY
2329	5.0.097.2329	TUBO CAMARA DE AR/PRESSOSTATO	TUBE BETWEEN AIR CHAMBER AND PRESSURE SWITCH
2362	5.0.097.2362	PORCA RACORD ASPIRAÇÃO	RACORD FASTENING NUT
2373	5.0.097.2373	RACORD ASPIRAÇÃO	SUCTION RACORD
2374	5.0.097.2374	ORING RACORD ASPIRAÇÃO	O'RING 6275
2401	5.0.097.2401	CESTO PRATOS (18) 500X500	DISHES BASKET 500X500
2450	5.0.097.2450	PORCA RACORD T (CERRA TUBO)	TUBE FASTENER
2502	5.0.097.2502	TAMPAO BRAÇO ENXAGUAMENTO	COVER OF THE RINSE HAND
2503	5.0.097.2503	RACORD T TUBO Ø6-2X TUBO Ø12	RETENSION VALVE

MÁQUINA LAVAR F 532 TR

LISTA DE COMPONENTES E ACESSÓRIOS

Spare parts list

ITEM Nº	CODIGO	DESIGNAÇÃO	DESIGNATION
2531	5.0.097.2531	ORING BRAÇO ENXAGUAMENTO	O'RING OR 106
2650	5.0.097.2650	TAMPAO BRAÇO LAVAGEM	CROSS PLASTIC COVER
2654	5.0.097.2654	MOLA	SPRING FOR CROSS PLASTIC COVER
2655	5.0.097.2655	TUBO ASPIRAÇÃO F430/F532/F1040	SUCTION TUBE
2733	5.0.097.2733	SEPARADOR INOX	INOX SPACER
2763		ADAPTADOR DA FALANGE	BEARING ADAPTOR
2779		FILTRO ANTI-PARASITAS 0,47MF	ANTI-PARASITES FILTER 0,47MF
2802	5.0.097.4731	VALVULA DVGW	DVGW VALVE BODY
2803	5.0.097.2803	PORCA VALVULA DVGW	FASTENING NUT FOR ANTI-FLOW VALVE
2808	5.0.097.2808	ANEL DISTRIBUIDOR	2RP DISTRIBUTOR PTFE RING
2868	5.0.097.2868	ELECTROBOMBA 1HP 230V-50HZ F532	ELECTRIC PUMP 1HP
2900	5.0.097.2900	VEIO RACORD ASPIRAÇÃO	FILTER SHAFT
2919	5.0.097.2919	GUIA DO TIRANTE	NYLON GUIDE
2927	5.0.097.2927	TUBO ANTI-CONDENSAÇÃO	RACORD ANTI-CONDENSATION
2933	5.0.097.2933	TUBO CAMARA DE AR	SMALL TUBE FOR AIR CHAMBER
2934	5.0.097.2934	ORING CAMARA AR	O'RING 20,22X3,53
2962	5.0.097.2962	TUBO BOMBA/BRAÇO F430/F532	ELEVATION TUBE
2991		TUBO CILINDRO M12X1M/F	STAINLESS STEEL TUBE
2995	5.0.097.2995	CALDEIRA 5LT F430/F532	BOILER
3055		RAMPA LAVAGEM	WASHING AREA
3072		TUBO Ø.30-37MM	TUBE Ø.30-37MM
3086	5.0.097.3086	JUNTA VALVULA DVGW	RUBBER GASKET
3164	5.0.097.3164	PORCA PERNO FIX. PORTA F1221N	NUT FOR FIXING SHAFT
3165	5.0.097.3165	CASQUILHO PORTA	DOOR SHAFT FIXING
3515	5.0.097.3515	CONCHA DISTRIBUIDORA	DISTRIBUTION SHELL
3528	5.0.097.3528	MICRO INTERRUPTOR	MICROSWITCH ASSEMBLY
3535	5.0.097.3535	CAMARA DE AR	AIR RETAINER
3536	5.0.097.3536	PORCA CAMARA DE AR	AIR RETAINER NUT
4042	5.0.097.4042	INTERRUPTOR GERAL	ON/OFF SWITCH
4043	5.0.097.4043	PULSADOR	PUSH BUTTON
4044	5.0.097.4044	BOTAO PRETO INTERRUPTOR	BLACK BUTTON Ø.16 H.9.8
4046	5.0.097.4046	CAIXA INTERRUPTOR	ORANGE LED
4084		JUNTA ADESIVA TAMPA INFERIOR	SELF-ADHESIVE GASKET
4090	5.0.097.4090	LAMPADA PILOTO BRANCA	ORANGE BULB LIGHT
4091	5.0.097.4091	LAMPADA PILOTO VERDE	GREEN BULB LIGHT
4092	5.0.097.4092	LAMPADA PILOTO LARANJA	WHITE BULB LIGHT
4120	5.0.097.4120	DISTRIBUIDOR 3 VIAS - TUBO Ø12	3-WAY DISTRIBUTOR
4159	5.0.097.4159	MICRO INTERRUPTOR DUPL0	DOUBLE MICROSWITCH ASSEMBLY
4163	5.0.097.4163	BRAÇO LAVAGEM/ENXAGUAMENTO F532	WASHING/RINSE ARM ASSEMBLY
4184	5.0.097.4184	TUBO NIVEL Ø35X140	LEVEL TUBE Ø35X140

MÁQUINA LAVAR F 532 TR

LISTA DE COMPONENTES E ACESSÓRIOS

Spare parts list

ITEM Nº	CODIGO	DESIGNAÇÃO	DESIGNATION
4322	4.0.001.0075	PULSADOR UNIPOLAR E2009	PUSH BUTTON CM-NA
4323	4.0.000.0513	INTERRUPTOR BIPOLAR E0070	SWITCH CM-NA BIP
4359	5.0.097.1669	INJECTOR ENXAGUAMENTO	RINSE NOZZLE
4374	5.0.097.1133	PARAFUSO FIXAÇÃO BRAÇO	STAINLESS STEEL SCREW
4671	5.0.097.4671	ANILHA ADAPTAÇÃO	SUPPORTING WASHER
4674	5.0.097.4674	CILINDRO Ø60X130	CYLINDER FOR ARM SUPPORT H131
4744	5.0.097.4744	TIRANTE PORTA	DOOR TENSIONER
4913	5.0.097.4913	TERMOSTATO 95°C CALDEIRA	THERMOSTAT 105°C
5140		CONTACTOR 230V 50-60HZ MC9	CONTACTOR 230V 50-60HZ MC9
5576	5.0.097.5576	TERMOMETRO	THERMOMETER
6143		JUNTA ADESIVA PORTA	SELF-ADHESIVE GASKET
6190		TAMPA	COVER ASSEMBLY
6299	5.0.097.6299	TERMOSTATO 60°C CUBA	60°C THERMOSTAT
6642	5.0.097.0189	CESTO TALHERES	BASKET FOR SPOONS
6662	5.0.097.0134	PE REGULAVEL	ADJUSTABLE FOOT
9528	5.0.097.5073	RACORD DOSEADOR DETERGENTE	DETERGENT DISPENSER RACORD
10246	5.0.097.0246	DOBRADIÇA PORTA DIR. F1221R	DOOR RIGHT HINGE
10247	5.0.097.0247	DOBRADIÇA PORTA ESQ. F1221R	DOOR LEFT HINGE
10293		JUNTA MICRO	MICROSWITCH GASKET
10294	5.0.097.0294	JUNTA DOBRADIÇA	HINGE GASKET
10351		MICRO INTERRUPTOR DUPLO	DOUBLE MICRO ASSEMBLY
10358		TAMPA INFERIOR	LOWER TRIM PANEL
10359		PAINEL POSTERIOR	REAR PANEL
10360		GUIA CESTO	BASKET GUIDE
10377		PAINEL COMANDO F532	COMAND PANEL
10473		REFORÇO DIR. SUPORTE CESTO	RIGHT ENFORCE
10474		REFORÇO ESQ. SUPORTE CESTO	LEFT ENFORCE
10723	5.0.097.0723	TEMPORIZADOR ELECTRONICO 2 MIN.	ELECTRONIC TIMER
10750	5.0.097.0750	RACORD L M22X1F-Ø12	ANGLE RACORD
10808		TAMPAO	STOPPER
35110	5.0.097.5110	PRESSOSTATO 55-30	PRESSURE SWITCH 55*30 C1200
TUB1	TUB1	TUBO 12X17	RUBBER TUBE 12X17

MÁQUINA LAVAR F 532 TR

ESQUEMA ELECTRICO (TEMPORIZADOR MECÂNICO)

LEGENDA:

PT	GB	
D1	DESVIADOR QUENTE / FRIO	HOT / COLD SWITCH
DDF	DOSEADOR DE DETERGENTE	DETERGENT DISPENSER
DDR	DOSEADOR REGULAVEL DETERGENTE	DETERGENT DISPENSER ADJUSTABLE
DPS	PULSAADOR PSC	PUSH BUTTON PSC
EV1	ELECTROVALVULA AGUA QUENTE	HOT SOLENOID VALVE
EV2	ELECTROVALVULA AGUA FRIA	COLD SOLENOID VALVE
H1	LAMPADA PILOTO - MAQ. LIG.	APPLIANCE ON INDICATOR LIGHT
H2	LAMPADA PILOTO - MAQ. PRONTA	APPLIANCE READY INDICATOR LIGHT
H3	LAMPADA PILOTO - CICLO DE LAVAGEM	WASH CYCLE INDICATOR LIGHT
IG	INTERRUPTOR GERAL	ON / OFF SWITCH
ILC	INTERRUPTOR LAVAGEM CONTINUA	CONTINUOUS WASH SWITCH
IM	INTERRUPTOR DA MÁQUINA	APPLIANCE SWITCH
K1	CONTACTOR DA CALDEIRA	BOILER CONTACTOR
K2	CONTACTOR DA CUBA	TANK CONTACTOR
K3	CONTACTOR DA BOMBA	PUMP CONTACTOR
KS	CONTACTOR DE SEGURANÇA	SAFETY CONTACTOR
M/M2	MICROINTERRUPTOR DA PORTA	DOOR SWITCH
MA	CAIXA DE LIGAÇÃO	MAINS CONNECTION TERMINAL BOARD
MT	MOTOR PROGRAMADOR	WASHER TIMER MOTOR
MTL	CONTACTOS PROGRAMADOR	WASHER TIMER SWITCH
PLV	BOMBA DE LAVAGEM	WASH PUMP
PR	PRESSOSTATO	PRESSURE SWITCH
PSC	BOMBA DE ESGOTO	DRAIN PUMP
PSP	BOMBA ADICIONAL	BOOSTER PUMP
RB	RESISTENCIA DA CALDEIRA	BOILER HEATING ELEMENT
RFI	FILTRO ANTIPARASITAS	SUPPRESSOR
RV	RESISTENCIA DA CUBA	TANK HEATING ELEMENT
START	BOTAO INICIO LAVAGEM	START WASH BUTTON
T1	TERMOSTATO DA CALDEIRA	BOILER THERMOSTAT
T2	TERMOSTATO DA CUBA	TANK THERMOSTAT
TS1	TERMOSTATO SEGURANÇA DA CALDEIRA	BOILER SAFETY THERMOSTAT
TS2	TERMOSTATO SEGURANÇA DA CUBA	TANK SAFETY THERMOSTAT

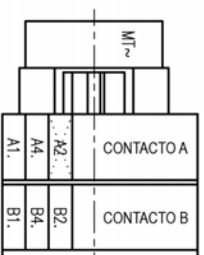
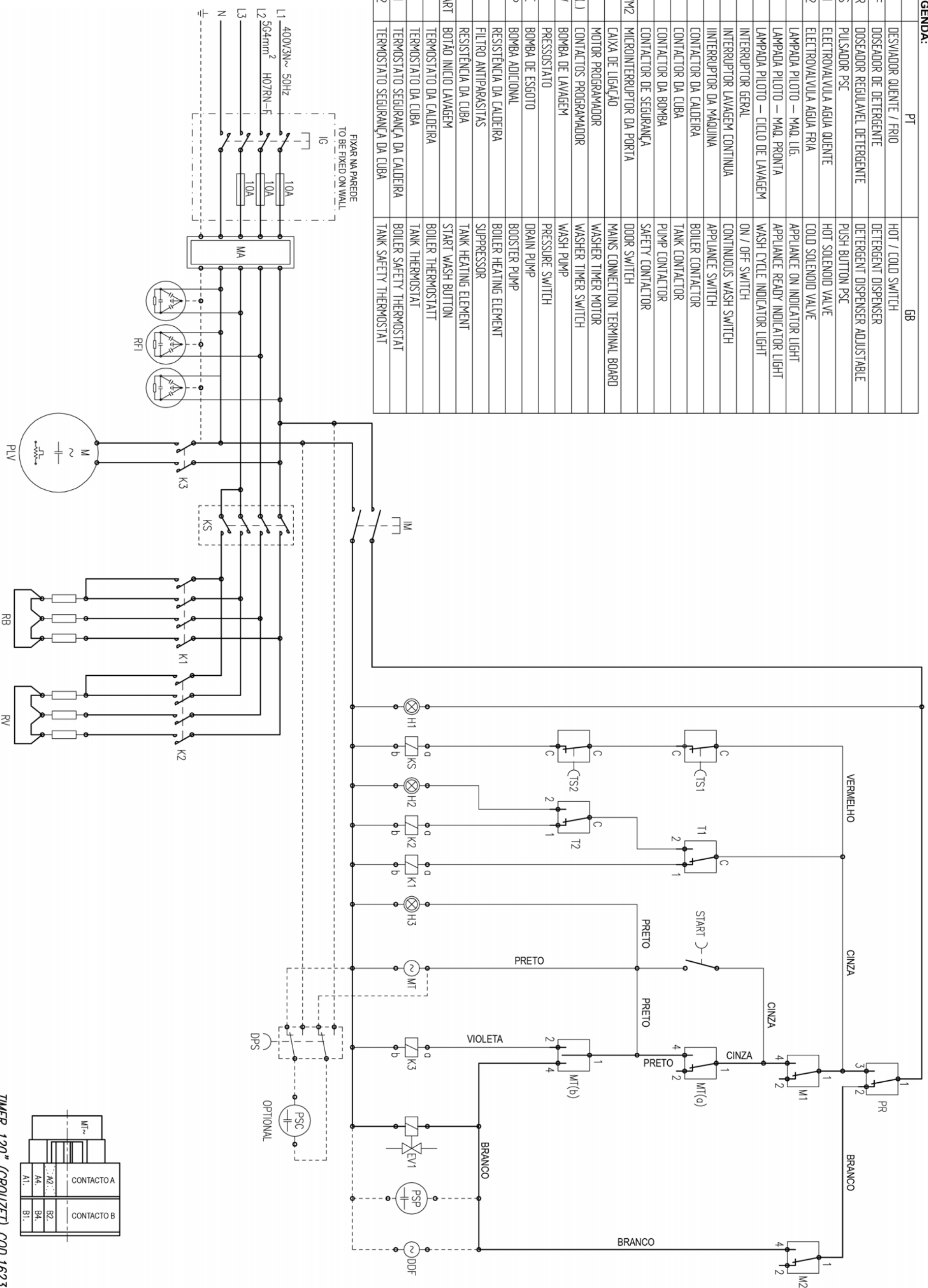

TIMER 120° (GROUZET) COD.1623

MÁQUINA LAVAR F 532 TR

ESQUEMA ELECTRICO (TEMPORIZADOR ELECTRÓNICO)

PT	GB
AZUL	BLUE
BRANCO	WHITE
CASTANHO	BROWN
CINZA	GREY
LARANJA	ORANGE
PRETO	BLACK
ROSA	PINK
VERDE	GREEN
VERMELHO	RED
VIOLETA	VIOLET

