

	*	**	***	****
G30-28+30mbar	533020800	533030200	533097000	531052400
G31- 37mbar	533020800	533120200	533096900	531052600
G30- 50mbar	533020300	533055800	533097000	531052400
G20- 20mbar	533020300	533055800	533096900	531052600
G25- 25mbar	533020300	533014300	533096900	531052600
G20- 20mbar DE-AT	533020300	533014200	533097000	531052400
G25- 20mbar	533020300	533014200	533097000	531052400
G25- 25mbar NL	533131000	533043100	533097000	531052400
GAS E-10IWC USA	533138900	533014400	533097000	531052400
GAS E-4IWC USA				

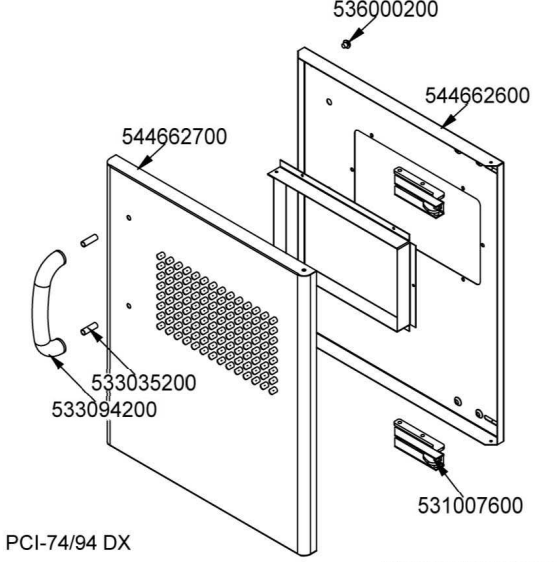

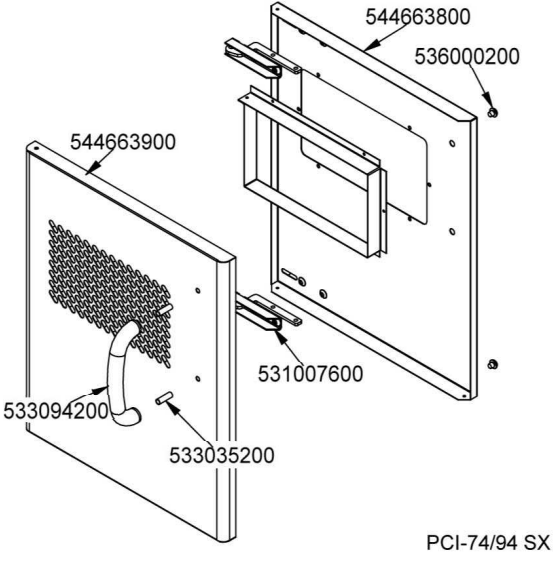

### BR BRM-G

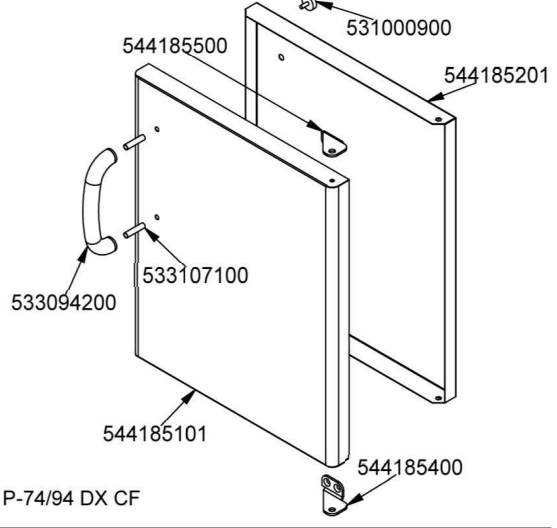
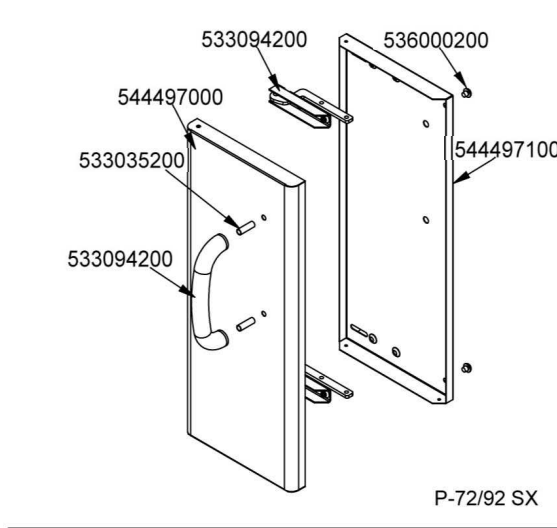
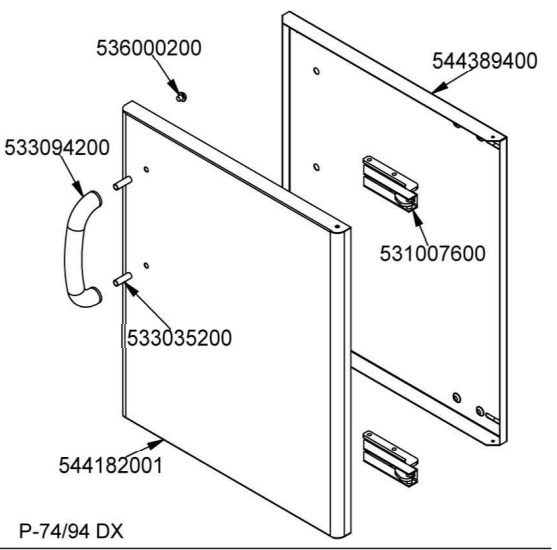
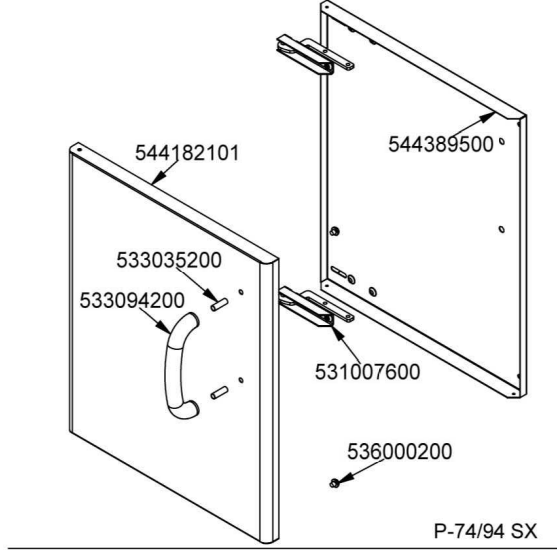
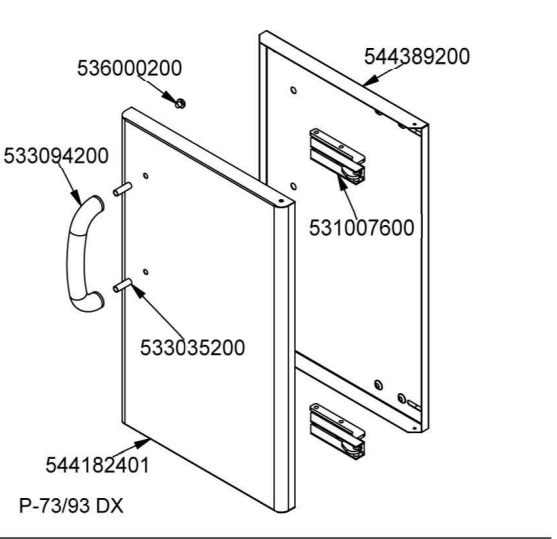
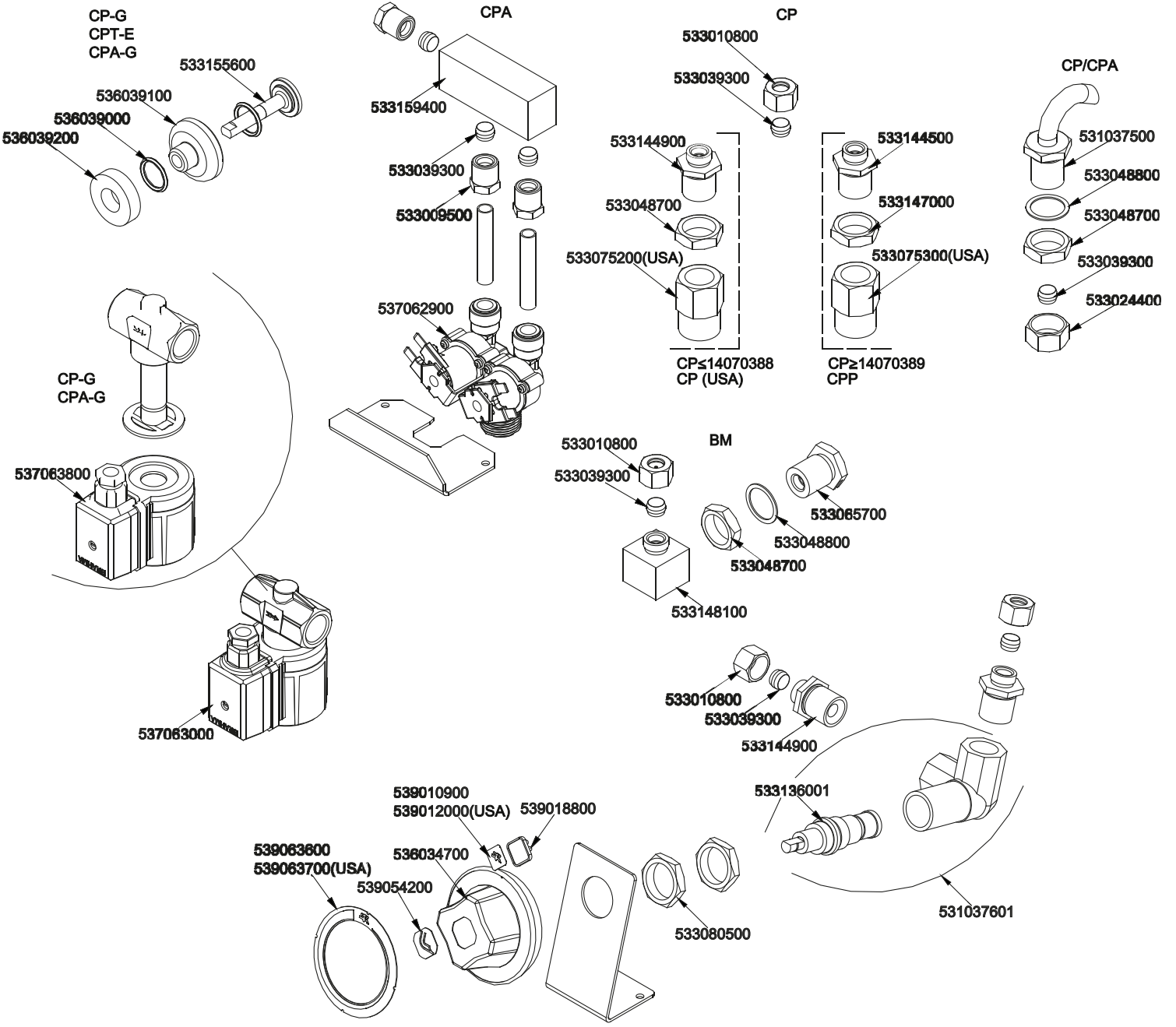
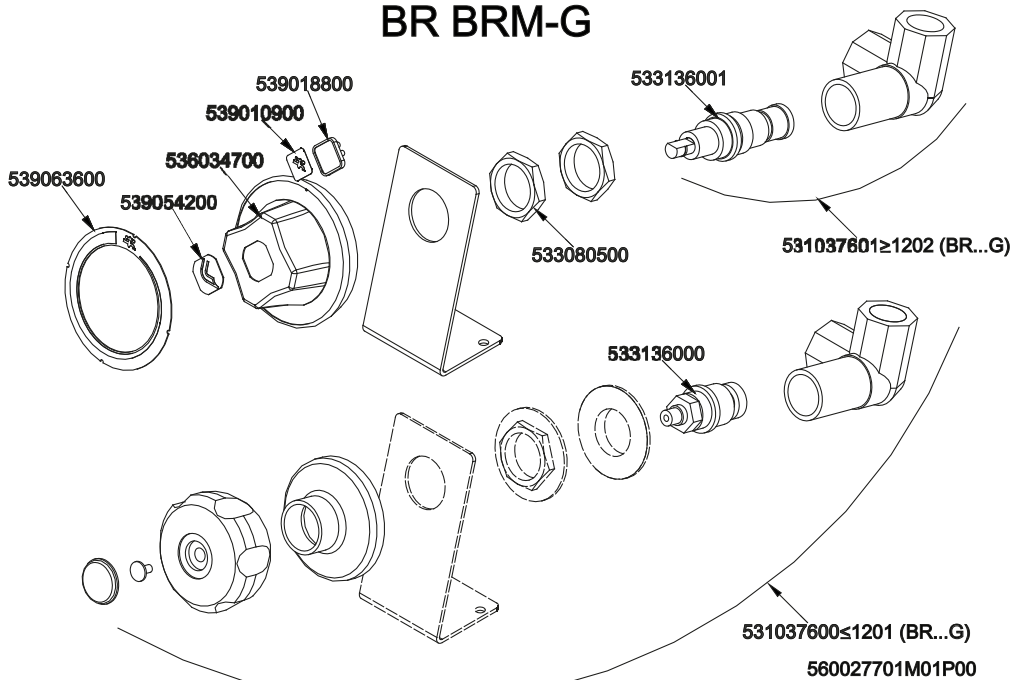

Page	Pos	Code	Description
001		532004100	FLUE GRID L=370 90LINE (RAF
001		541283001	ASS.PIANO S90 CPP-94G
001		531037701	BASKET SUPPORT GRID CP S.90
001		544412900	BASKET HOLDER FOR DRAINAGE OF CP90
001		531042800	SEMISPHERE FILTER
001		546006100	RUBBER TUBE §25INT.*§33EXT.*L=540
001		531018600	BALL VALVE 1"G M-F CPM-62G
001		533157400	FERMO PROLUNGA RUBINETTO 1"G Ø14
001		533157300	PROLUNGA RUB.1"G S90
001		533039900	PIPE HOLDER 1" G M D.24
001		544407400	LEFT SIDE PANEL 70 LINE
001		533040000	1"G F-F-F "T" FITTING
001		533149500	PROLUNGA 1 G M/M FE ZINC L100
001		533157500	RACC.A GOM.90° 1 G F.F.
001		533155600	PERNO PER SENSORE ACQUA
001		536039100	GUIDA PER SENSORE ACQUA
001		536039000	GUARNIZ.O-RING 12,42X1,78 SILIC.
001		536039200	DISTANZIALE PER SENSORE ACQUA
001		531034700	TUBULAR BURNER 10,5KW CPB-98G
001		541106503	ASS.CRUSC.S607090 CP-74G CP-94G
001		537062800	CENTR.SENS.ACQUA E RAB.CP 230V
001		537003800	TERMINAL BLOCK 3POLES 16A
001		537054400	TRASFOR.P.110V S.230V 30VA
001		534407300	
001		536005200	INOX LEG 2" 120-180 M10
002		533100100	GASKET §18
002		533100601	RACC.M24X1,5 F 1/2G M
002		533100700	GASKET §21
002		533039100	BICONE §6
002		533018500	FITTING FOR BICONE D.6 M10*1
002		539018900	INDEX FOR KNOB W/RED SIGN
002		537031901	RED WARNING LIGHT PCI 12V E FASTON
002		533076600	BICONE §20
002		533076400	HEXAGONAL NUT FOR BICONE DIAM.20
002		536034600	KNOB §77 4P. §10*8
002		539054200	STAMP Ø20,5 CR."L" LOTUS R.
002		539062800	RED STICKING DISK 72
002		533015601	
002		533001701	
002		541292200	ASS.SUPP.BRU.CPP-94G
002		537063000	ELETTROV.G.1/2GF-1/2GF 230V
002		537060300	IGNITION CONTROL BOX 2F. V30
002		533011500	PILOT BURNER 2 FLAMES 220
002		533045700	THERMOCOUPLE M9*1 500
002		533010400	BICONE D.6
002		547003200	HIGH-VOLTAGE CABLE TUBE.§2 L=500
002		533085200	SPACER FOR PILOT PLUG
002		537008300	ROUND PLUG §2,4- LONG ELECTRODE
002		533018600	PLUG FITTING
002		533020800	NOZZLE 0160-FLUSS. (25
002		533020300	NOZZLE 0160 (NATURAL GAS) 1-2 (41

Page	Pos	Code	Description
002		533131000	NOZZLE 0190 (30
002		533138900	NOZZLE 0190 (62
002		533030200	NOZZLE §170 CH12*14 MH-FG L-FP/CW
002		533120200	NOZZLE CH12X14,0 Ø148
002		533055800	NOZZLE CH12X14,0 Ø250
002		533014300	NOZZLE §285 CH12*14
002		533014200	NOZZLE §270 CH12*14 OVEN GN 3/1
002		533043100	NOZZLE §185 G25 CH12X14
002		533014400	NOZZLE §300 CH12*14 OVEN GN 3/1
002		533097000	COCK BY-PASS 24ST 23SV D150
002		533096900	COCK BY-PASS 24ST 23SV D125
002		531052400	RUB.GAS 23SO P.O.BY-P.Ø150
002		531052600	RUB.GAS 23SO P.O.BY-P.Ø125
003		544389300	CONTROP.73 SX APP. LT
003		531007600	DOOR HINGE
003		544182501	LEFT DOOR 73
003		533094200	S/S HANDLE FOR 70/90 SERIES
003		533035200	HANDLE SPACER
003		536000200	D.12 H.4 BUMPER
003		544389200	CONTROP.73 DX APP. LT
003		544182401	RIGHT DOOR 73
003		544182101	LEFT DOOR 74
003		544389500	INNER-DOOR OF LHD 74
003		544389400	CONTROP.74 DX APP. LT
003		544182001	RIGHT DOOR 74
003		544497000	PORTA 72 SX
003		544497100	CONTROP.72 SX APP. LT
003		544185101	RIGHT DOOR 74 CF
003		533107100	HANDLE SPACER OF CF-70
003		544185500	UPPER DOOR HINGE FOR COMPARTME CF70
003		531000900	MAGNET §22 KG.3 WITH DISK
003		544185201	INNER DOOR * 74DX
003		544185400	LOWER DOOR HINGE FOR COMPARTME CF70
003		544663900	LHD 74 DOOR FOR PCI
003		544663800	74 LHD OVEN INNER DOOR FOUR PCI
003		544662700	DOOR 74 DX PCI
003		544662600	CONTROP.74 DX APP. LT PCI
004		533010800	TUBE NUT D.10 M16*1,5
004		533155600	PERNO PER SENSORE ACQUA
004		536039100	GUIDA PER SENSORE ACQUA
004		536039000	GUARNIZ.O-RING 12,42X1,78 SILIC.
004		536039200	DISTANZIALE PER SENSORE ACQUA
004		533039300	BICONE §10
004		533159400	RACC.UN.2 U.ELETTROV.ACQUA CP
004		533144500	FITTING FOR WATER INPUT 3/4G
004		531037500	RACCORD CA.H2O 1/2G CAN.D10
004		533144900	MALE FITTING WATER INLET M16X1,5
004		533048700	NUT 1/2G ZN
004		533048800	GASKET §30*§21*2 FIBRE
004		533147000	BICONE FITTING 3/4G ZN
004		533009500	NIPPLE FOR BICONE 10S

Page	Pos	Code	Description
004		533024400	HEXAGONAL NUT 1/2G TUBE D.10
004		537062900	ELETTROV.A.3/4GM-2Ø10JG 230V RPV
004		537063800	COIL ELECTROV.G.1/2GF 230V
004		533065700	FITTING FOR WATER INPUT 1/2G
004		533148100	RACC.A GOM.90° 1/2G F.M16X1,5M. (S
004		537063000	ELETTROV.G.1/2GF-1/2GF 230V
004		539010900	ADHESIVE LABEL FOR DRAIN COCK
004		533136001	SCREW TAP WATER LOAD FOR CP S70/90
004		539012000	ADHESIVE LABEL FOR DRAIN COCK USA
004		539018800	BLANK INDEX FOR KNOB
004		539063600	ADHESIVE DISK 72 FOR DRAIN COCK
004		539063700	ADHESIVE DISK 72 FOR DRAIN COCK USA
004		536034700	KNOB §77 4P. §08*6,5 F§30
004		539054200	STAMP Ø20,5 CR."L" LOTUS R.
004		531037601	TAP FOR WATER 90°DX CP
004		533136000	SCREW TAP WATER LOAD FOR CP S70/90
004		531037600	TAP FOR WATER LOADING 1/2"GF CP 90