

# DISHWASHER

ELECTRONICAL SWITCHES  
LOWER AND UPPER WASHING  
INSULATED MODEL

TYPE: LUX61

Accessories  
BREAK TANK  
BOOSTER PUMP  
DVGW  
DETERGENT DISPENSER  
DRAIN PUMP

---

## Spare Parts Manual

---

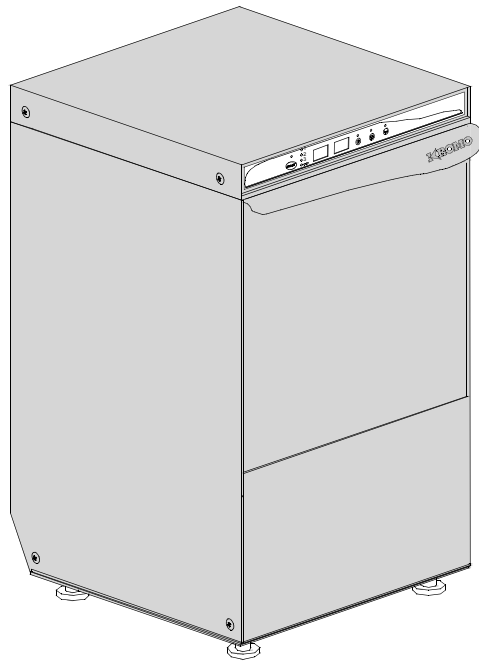

## INFORMAZIONI GENERALI

Questo catalogo serve per richiedere con esattezza le parti di ricambio

Nelle ordinazioni indicare:

1) il numero dei codici dei particolari seguito dalla descrizione e la quantità desiderata;

2) Il codice alfa-numerico presente nella seconda colonna della tabella ;

**I disegni delle parti di ricambio sono solo indicativi e non rappresentano il pezzo in oggetto.**

**I dati contenuti in questo catalogo sono indicativi e possono essere soggetti a modifiche senza impegno di preavviso.**

## ALLGEMEINE INFORMATIONEN

Dieser Ersatzteilkatalog dient zur genauen Angabe der Teile bei Ersatzteilbestellungen.

Bei Ersatzbestellung ist folgendes anzugeben:

1) Die Bestellnummer der Ersatzteile mit der entsprechenden Beschreibung genaue Menge;

2) Der alpha-numerischer Code auf der zweiten Reihe in dein Sculd;

**Die Zeichnungen der Ersatzteile sind nur als Hinweise gedacht und stellen nicht das betroffene Teil dar.**

**Bei den im Katalog angeführten Daten handelt es sich um Anhaltsdaten, die jederzeit, ohne Vorankündigung, geändert werden können.**

## GENERAL INFORMATION

The present spare parts order exactly the right spare parts

When ordering specify:

1) the part's code number followed by its description and quantity needed;

2) The alpha-numeric code is in the second column in the chart;

**Spare parts drawings are general and do not represent the part.**

**The contents of this catalogue are general and can undergo changes without prior notice.**

## INFORMACIONES GENERALES

El presente catálogo sirve para pedir con exactitud las partes de repuesto

En los pedidos se debe indicar:

1) el número de código de la parte y a continuación la descripción cantidad deseada;

2) El código alfanumerico presente en la segnada columna de la tabla;

**Los diseños de las partes de recambio son solo indicativos y no representan la pieza en cuestión.**

**Los datos contenidos en el presente catálogo son indicativos y pueden modificarse sin aviso previo.**

## INFORMATIONS GENERALES

Ce catalogue permet de commander correctement les pièces détachées

Les commandes doivent être passées en indiquant:

1) le numero de code des pièces détachées suivi de leur description quantité désirée;

2) le code alphanumérique dans la deuxième colonne du tableau;

**Les plans des pièces détachées sont fournis seulement à titre indicatif et ne représentent pas la pièce concernée.**

**Les données de ce catalogue sont citées seulement à titre indicatif et peuvent être l'objet de modifications sans avis préalable.**

ESEMPIO  
EXAMPLE  
EXEMPLE  
BEISPIEL

Rif.	Codici
MODULE:Particolari	
10505	540903
10510	540908
10515	15065/A
10520	540086
10525	540028

**Note**

Tutte le informazioni riportate si intendono aggiornate alla data di stampa. Il Produttore si riserva il diritto di apportare qualsiasi modifica richiesta dallo sviluppo evolutivo dei suddetti prodotti.

Per la sicurezza, la garanzia, l'affidabilità ed il valore della lavastoviglie usa solo ricambi originali. **Per alcuni codici, sono richieste quantità minime d'ordine.**

**Attenzione**

Questo libretto è parte integrante della lavastoviglie e, in caso di passaggio di proprietà, deve essere consegnato al nuovo acquirente.

**Remarque**

Toutes les informations contenues dans ce manuel s'entendent mises à jour à la date d'impression. En raison du développement constant de ses produits, usine se réserve le droit d'apporter à tout instant les modifications qu'elle jugera utiles.

Pour la sécurité, la garantie, la fiabilité et la valeur de votre lavevaisselles n'utilisez que des pièces de rechange d'origine. **Pour quelque référence on demande un minimum de pièces par commande**

**Attention**

Ce manuel doit être considéré comme partie intégrante de la la lavevaisselles, en cas de transfert de propriété, doit toujours être remis au nouveau propriétaire.

**Note**

The information contained herein is valid at the time of going to print. The Company reserves the right to make any changes required by the future development of the above-mentioned products.

For your safety, as well as to preserve the warranty reliability and worth of your dishwashers, use original spare parts only. **For some codes a minimum quantity for order is required.**

**Warning**

This manual forms an integral part of the dishwashers and - if a transfer of title occurs - must always be handed over to the new owner.







**Hinweis**

Die Der Hersteller behält sich das Recht vor, jegliche, durch eine Weiterentwicklung der genannten Produkte bedingte Änderungen vornehmen zu können.

Verwenden Sie für Ihre Sicherheit, die Garantie, die Zuverlässigkeit und den Wert Ihrer machine originale Ersatzteile. **Für bestimmte Code nummer werden mindesten bestellungen verlangt.**

**Achtung**

Diese Betriebsanleitung ist Bestandteile des machine und muss bei seinem Weiterverkauf dem neuen Besitzer ausgehändigt werden.

	
<b>Code 999XYYYY</b> <span style="float: right;"><b>CL/Part</b></span>	
<b>Model DESCRIPTION</b> <span style="float: right;"></span>	
<b>S/N 04012345</b> <b>Type .....</b>	
400VAC3N    50HZ    8A 3500W                    500W	<b>TECHICAL SPECIFICATION</b>
  16A	
Pressione Dinamica alimentazione idrica <b>200-500</b> Pression dynamique arrivee d'eau Dynamic pressure water supply Dynamischer Druck asserreinlauf	<b>MADE IN ITALY</b>
Pressione dinamica vapore saturo Pression dynamique vapeur satuee Dymanischer Druck gesattigter Dampf Pression Dinamica Vapor Saturado	Temperatura massima acqua in ingresso <b>60°C</b> Temperature max eau a l'entre Maximale Temperatur Wasseranschlu Maximum Water temperature in-feeding
<b>Model</b> 	<b>S/N</b> 

**CODE 999 XX YYYY**

FAMIGLIA PRODOTTO  
FAMILY PRODUCT  
FAMILLE DU PRODUIT  
FAMILIA PRODUCTO  
FAMILIE DES PRODUKTES

CODICE MODELLO  
CODE MODEL  
CODE ARTICLE  
CODIGO MODELO  
KODE VON MODELL

**S/N 04 012345**

ANNO  
YEAR  
ANNÉE  
AN<sup>o</sup>  
JAHR

NUMERO DI SERIE  
SERIAL NUMBER  
NUMÉRO DI SÉRIE  
NUMERO DI SERIE  
SERIENNUMMER



## 1. Spare parts

General body parts.....	7
Lockup system .....	9
Electric control components.....	11
Command electronic control .....	13
Solenoid valve group .....	15
Break Tank .....	17
Booster pump.....	19
DVGW .....	21
Rinse aid dispenser group.....	23
Rinse aid dispenser group.....	25
Boiler group .....	27
3 ways connection .....	29
Wash pump .....	31
Dosing detergent group.....	33
Drain pump group.....	35
Pressure switch group with air trap ...	37

**Turret group with rotating arms .....39**

## 1.1 Voltage codes

Volt	Voltage code
A	3/N/PE~380-400V 50-60Hz
D	3/PE~200-210V 50-60Hz
F	2/PE~220-240V 50-60Hz
G	3/N/PE~415V 50-60Hz
H	3/PE~220-230V 50-60Hz
K	3/PE~380-400V 50-60Hz
L	3/PE~415V 50-60Hz
M	3/PE~440V 60Hz
P	1/N/PE~220-230V 50-60Hz
R	2/PE~220-240V 50-60Hz
U	1/N/PE~240V 50-60Hz
V	3/PE~240V 50-60Hz
W	1/N/PE~100-110V 50-60Hz

## 1.2 Product codes

Product code	Full name
Model codes	
e	ELECTRONICAL SWITCHES
uw	LOWER AND UPPER WASHING
i	INSULATED MODEL
Type codes	
LUX61	LUX61
Accessory codes	
bt	BREAK TANK
bp	BOOSTER PUMP
dvgw	DVGW
dd	DETERGENT DISPENSER
dp	DRAIN PUMP

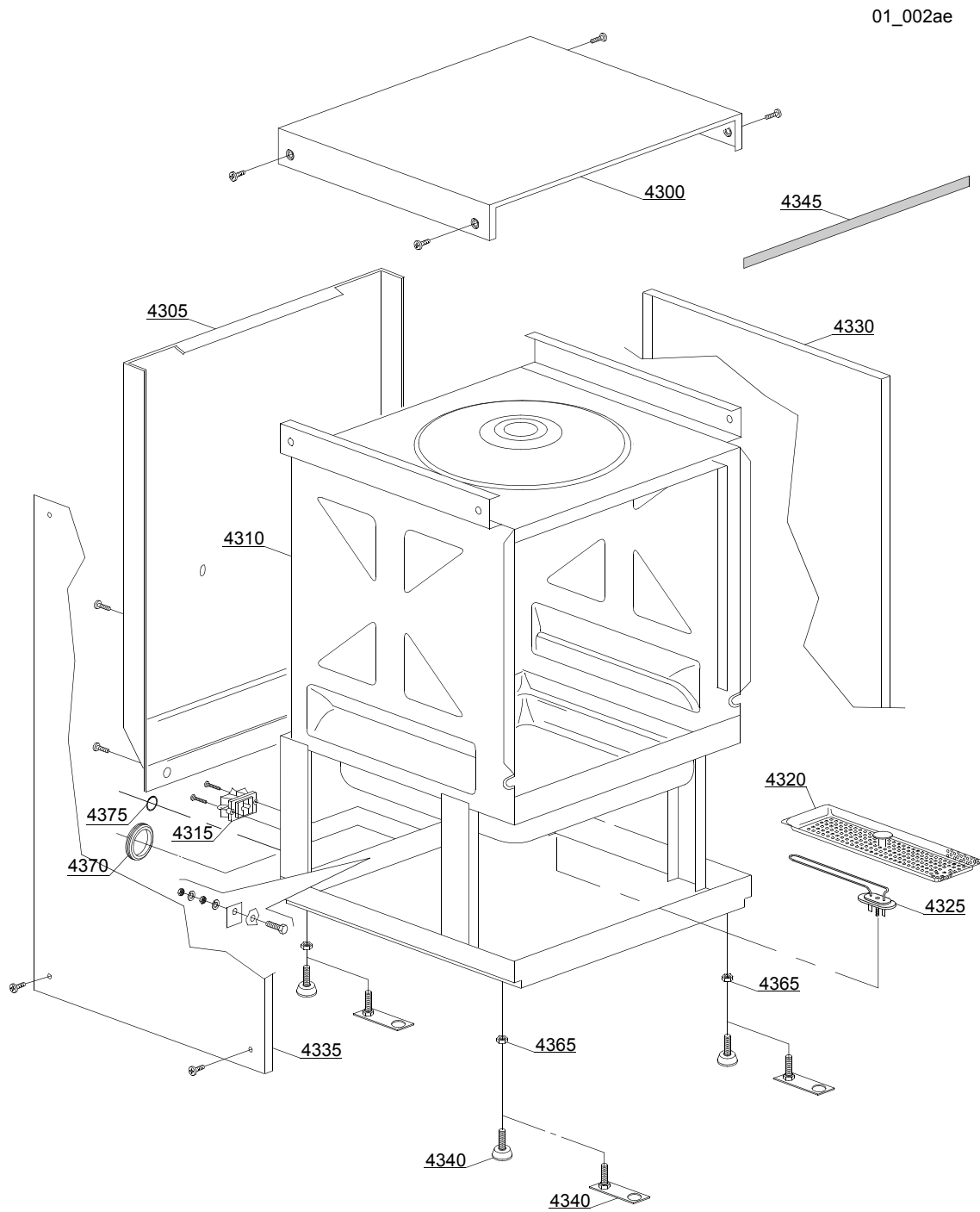

## Spare parts

ID	P-code	SN from	SN to	Mod.	Acces.	Volt	Description
<b>Module:General body parts</b>							
4300	560917		-	i,e			Cover
4305	560919		-	i,e			Back panel
4305	560938		-	i,e	bt		Back panel
4315	15065/A		-	i,e			Cable-fastener with screw
4320	561009		-	i,e			Surface filter
4325	540406		-	i,e			0,4/0,44KW 230/240V heating element
4330	560914		-	i,e			Right side
4335	560915		-	i,e			Left side
4340	10786		-	i,e			M10x25 Ø40 black foot (minimum 4 pieces)
4340	15176		-	i,e			M10 marina foot
4345	560021		-	i,e			Profile for door O-ring
4365	11711		-	i,e			M10 zinc plated nut (minimum 20 pieces)
4370	13317		-	i,e			D.40mm unloading pipe pass (minimum 2 pieces)
4375	13323		-	i,e			D.13mm dosing pipe pass (minimum 2 pieces)

e=ELECTRONICAL SWITCHES, uw=LOWER AND UPPER WASHING, i=INSULATED MODEL

LUX61=LUX61

bt=BREAK TANK, bp=BOOSTER PUMP, dvgw=DVGW, dd=DETERGENT DISPENSER, dp=DRAIN PUMP

A=3/N/PE~380-400V 50-60Hz, D=3/PE~200-210V 50-60Hz, F=2/PE~220-240V 50-60Hz, G=3/N/PE~415V 50-60Hz, H=3/PE~220-230V 50-60Hz, K=3/PE~380-400V 50-60Hz, L=3/PE~415V 50-60Hz, M=3/PE~440V 60Hz, P=1/N/PE~220-230V 50-60Hz, R=2/PE~220-240V 50-60Hz, U=1/N/PE~240V 50-60Hz, V=3/PE~240V 50-60Hz, W=1/N/PE~100-110V 50-60Hz

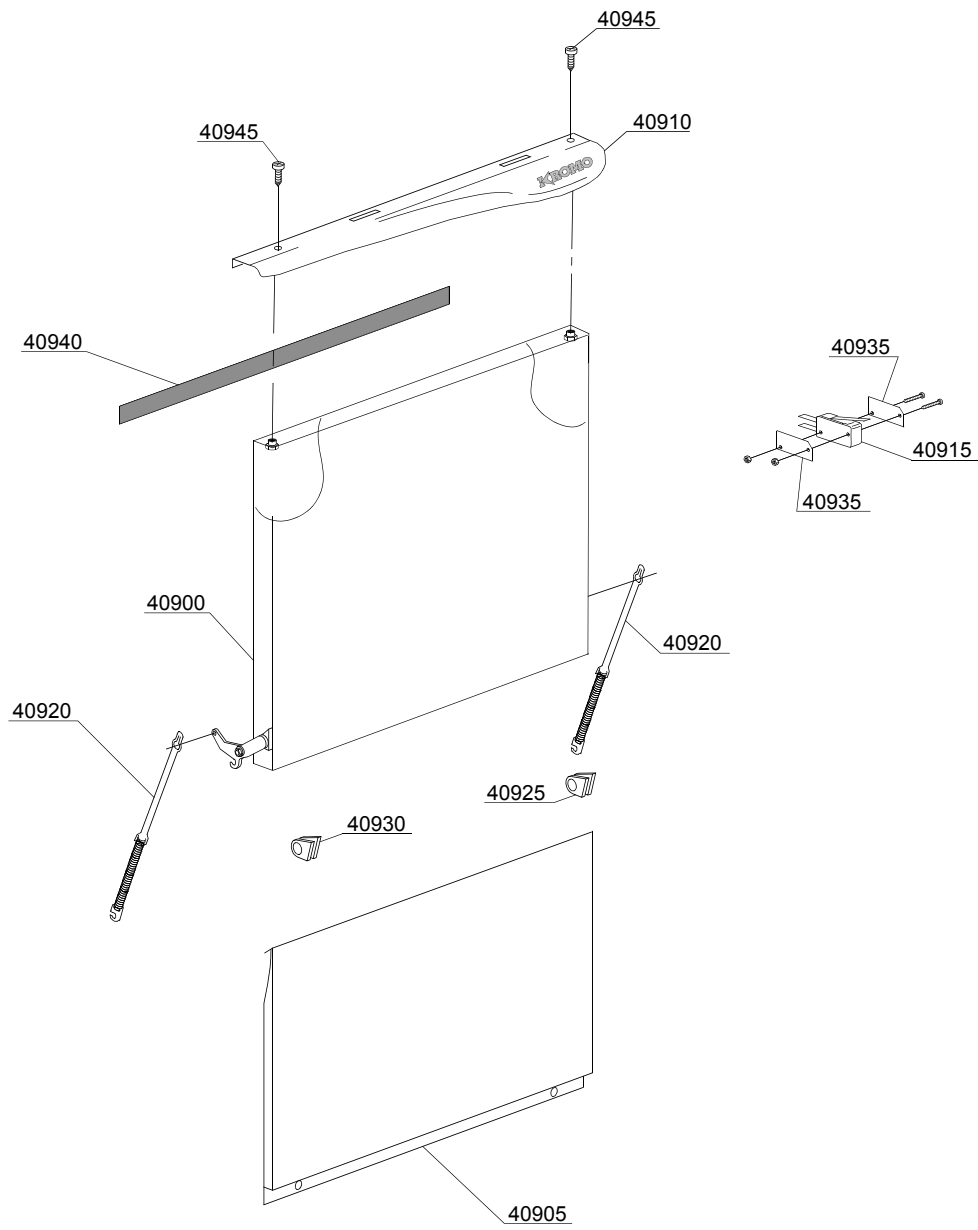

02\_128\_e

## Spare parts

ID	P-code	SN from	SN to	Mod.	Acces.	Volt	Description
<b>Module: Lockup system</b>							
40900	570002		-				Door with steel handle
40905	570005		-				Lower door
40910	560965		-				KROMO Stainless steel handle
40910	560965/N		-				NEUTRAL Stainless steel handle
40915	10704		-				Door microswitch
40920	570200		-				Door spring
40925	560006		-				Right lock for door hinge (minimum 2 pieces)
40930	560007		-				Left lock for door hinge (minimum 2 pieces)
40935	10770		-				Insulation for door microswitch (minimum 3 pieces)
40940	560021		-				Profile for door O-ring
40945	11220		-				M4x14 TCB-CR Inox Screw
40950	11226		-				M4 inox Plated nut

e=ELECTRONICAL SWITCHES, uw=LOWER AND UPPER WASHING, i=INSULATED MODEL

LUX61=LUX61

bt=BREAK TANK, bp=BOOSTER PUMP, dvgw=DVGW, dd=DETERGENT DISPENSER, dp=DRAIN PUMP

A=3/N/PE~380-400V 50-60Hz, D=3/PE~200-210V 50-60Hz, F=2/PE~220-240V 50-60Hz, G=3/N/PE~415V 50-60Hz, H=3/PE~220-230V 50-60Hz, K=3/PE~380-400V 50-60Hz, L=3/PE~415V 50-60Hz, M=3/PE~440V 60Hz, P=1/N/PE~220-230V 50-60Hz, R=2/PE~220-240V 50-60Hz, U=1/N/PE~240V 50-60Hz, V=3/PE~240V 50-60Hz, W=1/N/PE~100-110V 50-60Hz

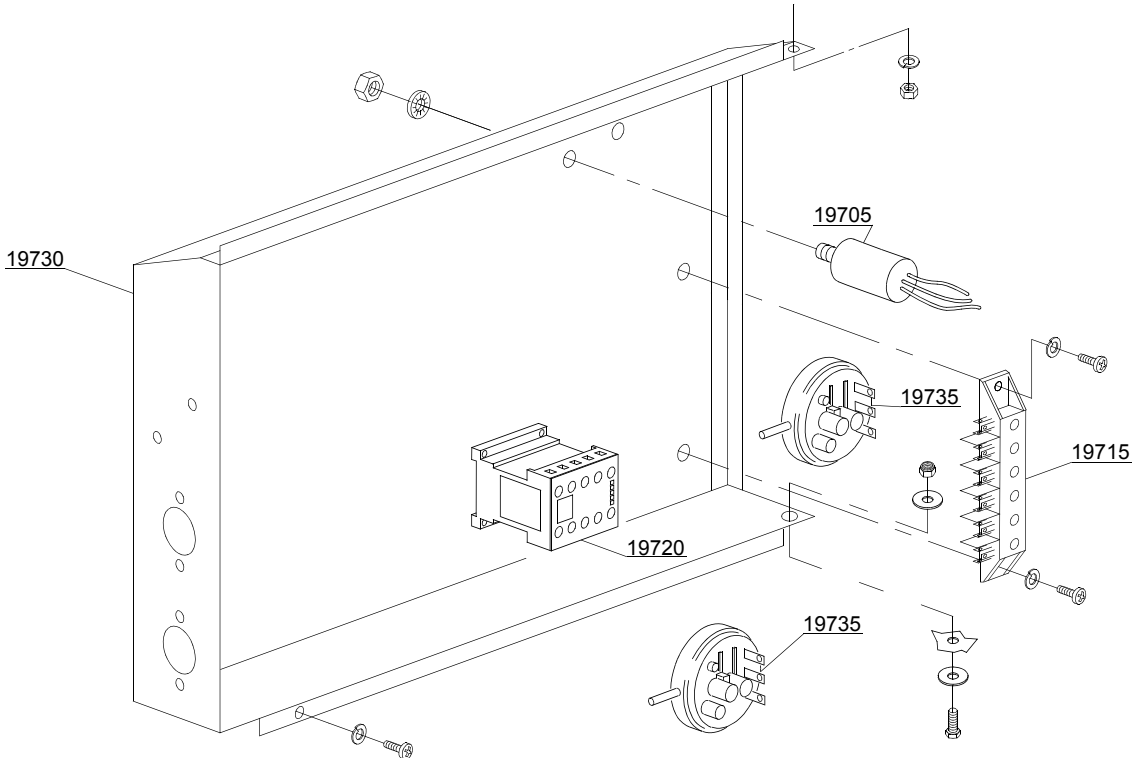

04\_019ae

## Spare parts

ID	P-code	SN from	SN to	Mod.	Acces.	Volt	Description
<b>Module:Electric control components</b>							
19705	15149		-	i,e			Low noise filter
19715	500551		-	i,e			6 poles terminal board
19720	15086		-	i,e			Contactor 230V 50/60Hz 4C
19720	15086/B		-	i,e			Contactor 240V 50Hz
19730	560921		-	i,e			Electric components panel
19735	10300026		-	i,e			76-38 pressure switch
19735	80225		-	i,e			18-100 pressure switch

e=ELECTRONICAL SWITCHES, uw=LOWER AND UPPER WASHING, i=INSULATED MODEL

LUX61=LUX61

bt=BREAK TANK, bp=BOOSTER PUMP, dvgw=DVGW, dd=DETERGENT DISPENSER, dp=DRAIN PUMP

A=3/N/PE~380-400V 50-60Hz, D=3/PE~200-210V 50-60Hz, F=2/PE~220-240V 50-60Hz, G=3/N/PE~415V 50-60Hz, H=3/PE~220-230V 50-60Hz, K=3/PE~380-400V 50-60Hz, L=3/PE~415V 50-60Hz, M=3/PE~440V 60Hz, P=1/N/PE~220-230V 50-60Hz, R=2/PE~220-240V 50-60Hz, U=1/N/PE~240V 50-60Hz, V=3/PE~240V 50-60Hz, W=1/N/PE~100-110V 50-60Hz

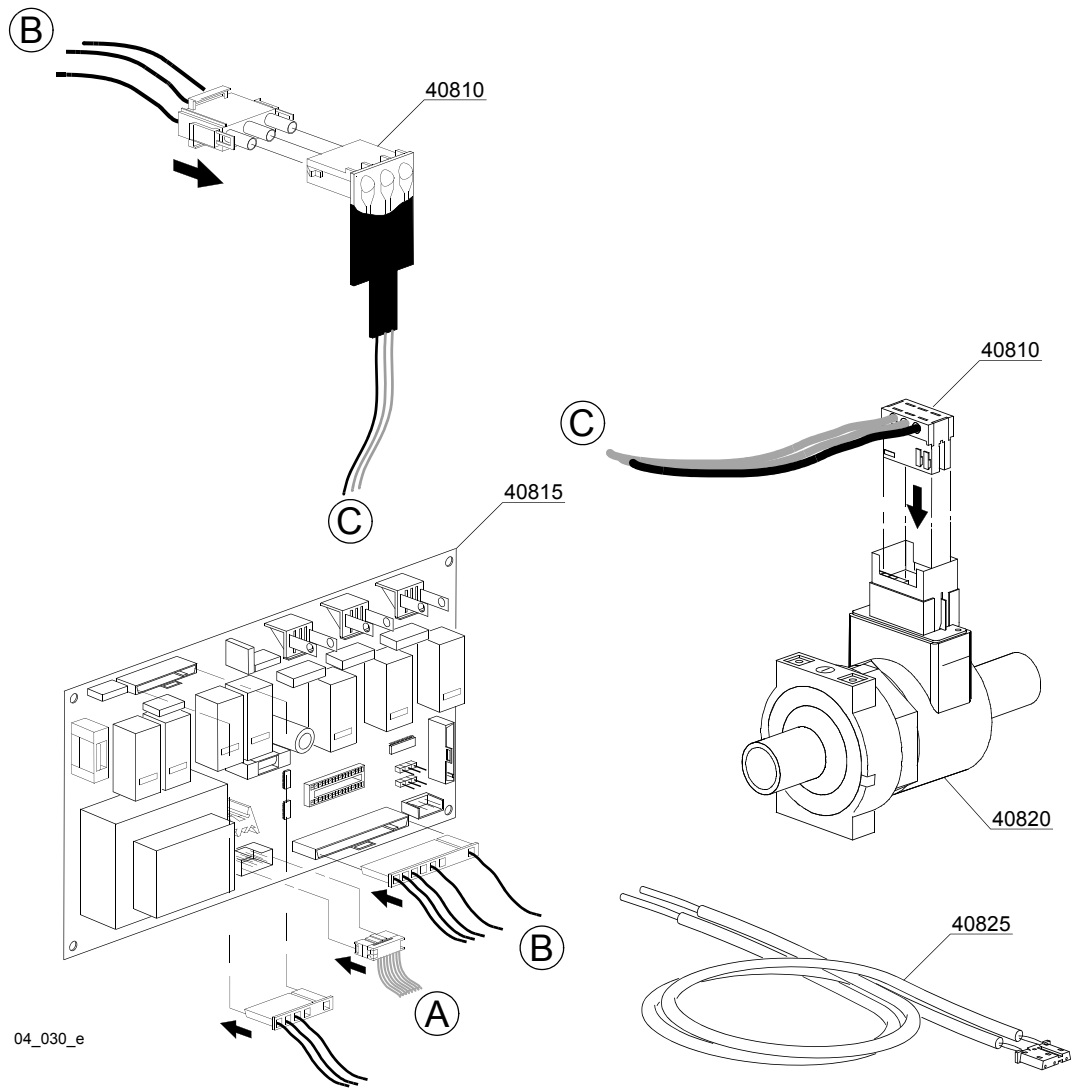
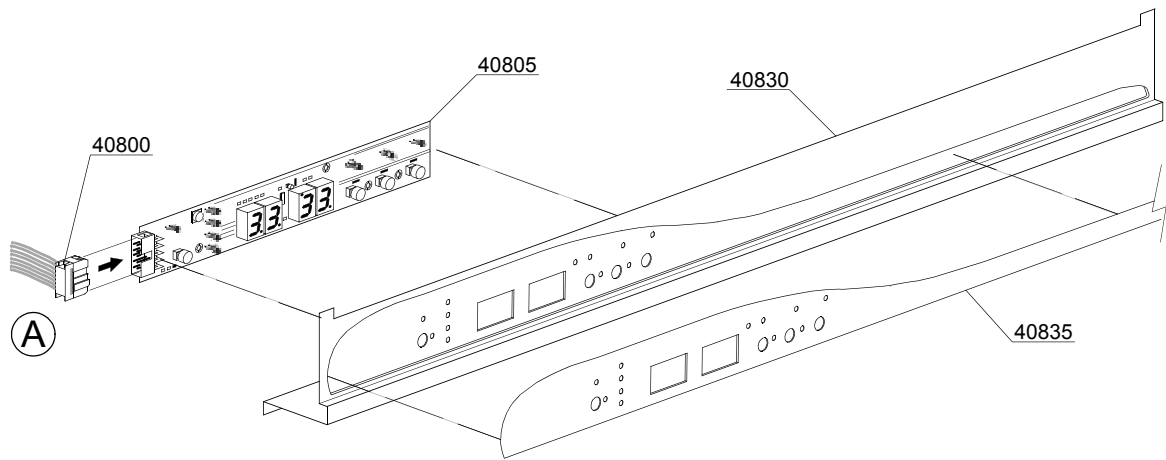

04\_030\_e

## Spare parts

ID	P-code	SN from	SN to	Mod.	Acces.	Volt	Description
<b>Module:Command electronic control</b>							
40800	50582		-				Plug
40805	50581		-				Touche sensitive
40810	50584		-				Water flow board
40815	50580		-				Electronic timer+main board
40815	50590		-				Electronic timer+main board BA
40820	50583		-				Water flow meter for board
40825	50562		-				Temperature probe set
40830	560967		-				Control Panel
40835	560968		-				Silkscreen processed grill

e=ELECTRONICAL SWITCHES, uw=LOWER AND UPPER WASHING, i=INSULATED MODEL

LUX61=LUX61

bt=BREAK TANK, bp=BOOSTER PUMP, dvgw=DVGW, dd=DETERGENT DISPENSER, dp=DRAIN PUMP

A=3/N/PE~380-400V 50-60Hz, D=3/PE~200-210V 50-60Hz, F=2/PE~220-240V 50-60Hz, G=3/N/PE~415V 50-60Hz, H=3/PE~220-230V 50-60Hz, K=3/PE~380-400V 50-60Hz, L=3/PE~415V 50-60Hz, M=3/PE~440V 60Hz, P=1/N/PE~220-230V 50-60Hz, R=2/PE~220-240V 50-60Hz, U=1/N/PE~240V 50-60Hz, V=3/PE~240V 50-60Hz, W=1/N/PE~100-110V 50-60Hz

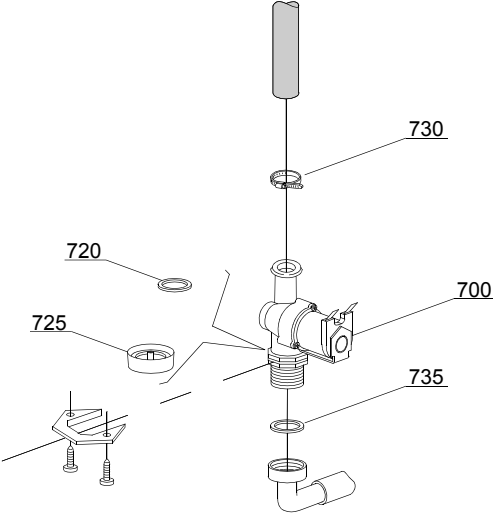

05\_002\_e

## Spare parts

ID	P-code	SN from	SN to	Mod.	Acces.	Volt	Description
<b>Module:Solenoid valve group</b>							
700	10703		-	i,e			Single solenoid valve - 230Vac
720	N.C.		-	i,e			Pression reducing valve
730	11807		-	i,e			12/22 clamp (minimum 3 pieces)
735	13307		-	i,e			3/4 gasket

e=ELECTRONICAL SWITCHES, uw=LOWER AND UPPER WASHING, i=INSULATED MODEL

LUX61=LUX61

bt=BREAK TANK, bp=BOOSTER PUMP, dvgw=DVGW, dd=DETERGENT DISPENSER, dp=DRAIN PUMP

A=3/N/PE~380-400V 50-60Hz, D=3/PE~200-210V 50-60Hz, F=2/PE~220-240V 50-60Hz, G=3/N/PE~415V 50-60Hz, H=3/PE~220-230V 50-60Hz, K=3/PE~380-400V 50-60Hz, L=3/PE~415V 50-60Hz, M=3/PE~440V 60Hz, P=1/N/PE~220-230V 50-60Hz, R=2/PE~220-240V 50-60Hz, U=1/N/PE~240V 50-60Hz, V=3/PE~240V 50-60Hz, W=1/N/PE~100-110V 50-60Hz

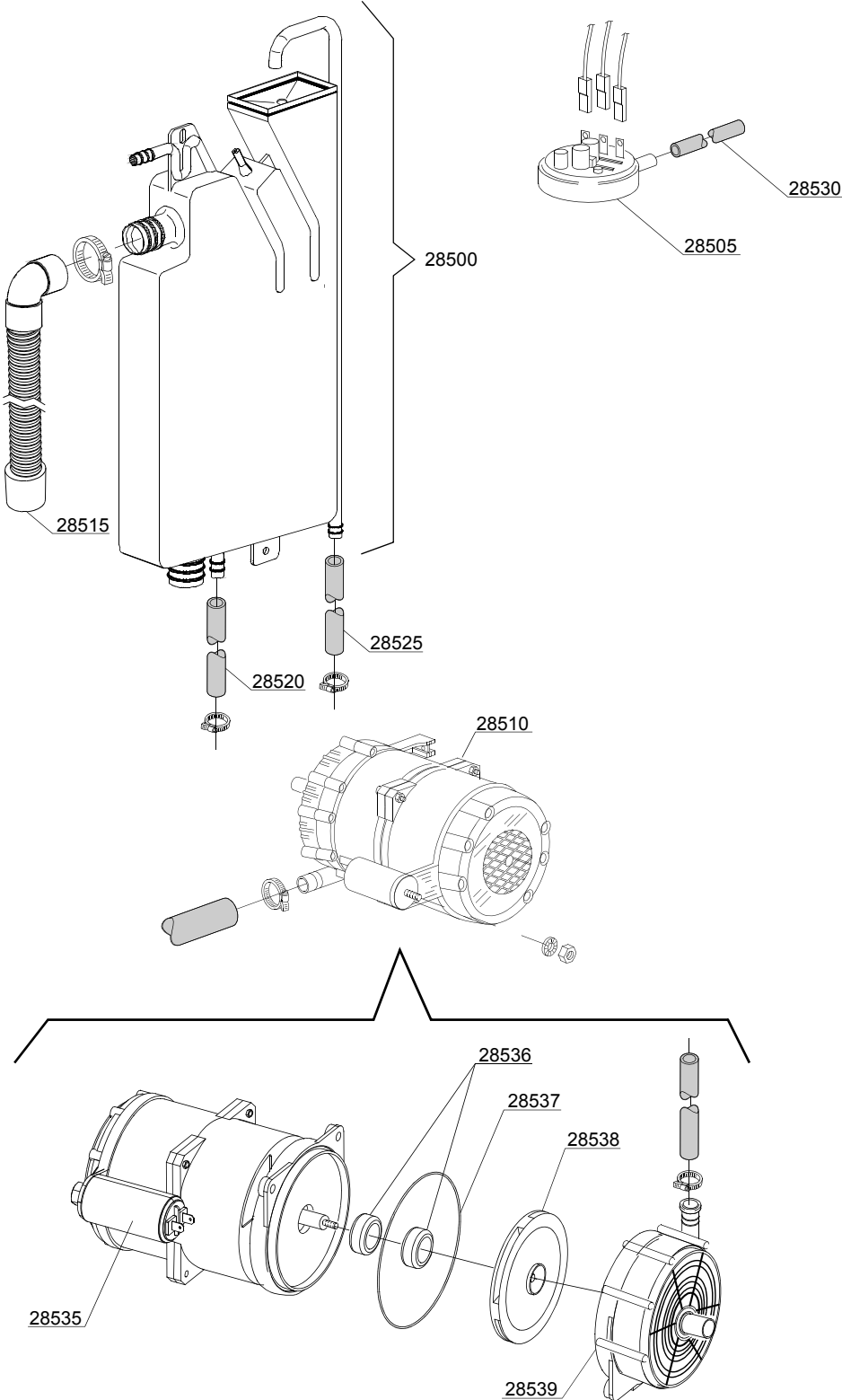

06\_004ae

## Spare parts

ID	P-code	SN from	SN to	Mod.	Acces.	Volt	Description
<b>Module:Break Tank</b>							
28500	15735		-	e,i	bt		Break tank assembly
28505	10706/A		-	e,i	bt		47-27 pressure switch
28510	15100/D		-	e,i	bt		Booster pump 220/240V - body pumps in plastic
28515	15721		-	e,i	bt		BT long pipe L=1070
28515	15722		-	e,i	bt		BT middle pipe L=920
28515	15723		-	e,i	bt		BT small pipe L=690
28520	2907350		-	e,i	bt		12x20 EPDM rubber hose
28525	2907352		-	e,i	bt		PVC WRAS rubber hose
28530	14508		-	e,i	bt		4,5x9 EPDM rubber hose (minimum 2 mt)
28535	10702		-	e,i	bt		5 uF condenser - 450V
28536	15100/S		-	e,i	bt		Rotating seals
28537	15100/T		-	e,i	bt		OR-(O-ring) gasket EPDM
28538	15100/U		-	e,i	bt		Pump rotor
28539	15100/V		-	e,i	bt		Scroll

e=ELECTRONICAL SWITCHES, uw=LOWER AND UPPER WASHING, i=INSULATED MODEL

LUX61=LUX61

bt=BREAK TANK, bp=BOOSTER PUMP, dvgw=DVGW, dd=DETERGENT DISPENSER, dp=DRAIN PUMP

A=3/N/PE~380-400V 50-60Hz, D=3/PE~200-210V 50-60Hz, F=2/PE~220-240V 50-60Hz, G=3/N/PE~415V 50-60Hz, H=3/PE~220-230V 50-60Hz, K=3/PE~380-400V 50-60Hz, L=3/PE~415V 50-60Hz, M=3/PE~440V 60Hz, P=1/N/PE~220-230V 50-60Hz, R=2/PE~220-240V 50-60Hz, U=1/N/PE~240V 50-60Hz, V=3/PE~240V 50-60Hz, W=1/N/PE~100-110V 50-60Hz

07\_003\_e

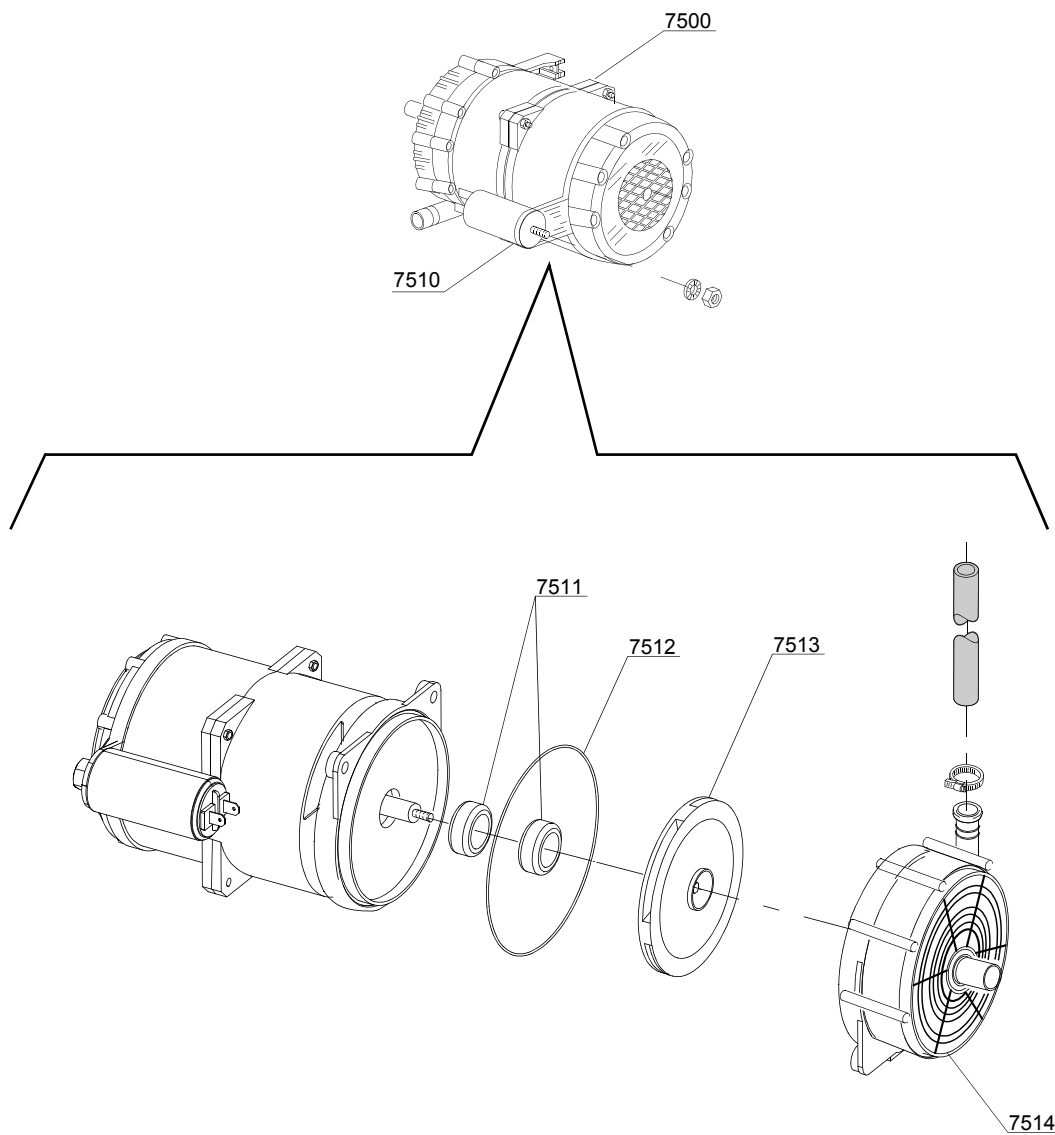

## Spare parts

ID	P-code	SN from	SN to	Mod.	Acces.	Volt	Description
<b>Module:Booster pump</b>							
7500	15100/D		-	e,i	bp		Booster pump 220/240V - body pumps in plastic
7505	12013		-	e,i	bp		Rubber-holder
7510	10702		-	e,i	bp		5 uF condenser - 450V
7511	15100/S			e,i	bp		Rotating seals
7512	15100/T			e,i	bp		OR (O-ring) gasket EPDM
7513	15100/U			e,i	bp		Pump rotor
7514	15100/V			e,i	bp		Scroll

e=ELECTRONICAL SWITCHES, uw=LOWER AND UPPER WASHING, i=INSULATED MODEL

LUX61=LUX61

bt=BREAK TANK, bp=BOOSTER PUMP, dvgw=DVGW, dd=DETERGENT DISPENSER, dp=DRAIN PUMP

A=3/N/PE~380-400V 50-60Hz, D=3/PE~200-210V 50-60Hz, F=2/PE~220-240V 50-60Hz, G=3/N/PE~415V 50-60Hz, H=3/PE~220-230V 50-60Hz, K=3/PE~380-400V 50-60Hz, L=3/PE~415V 50-60Hz, M=3/PE~440V 60Hz, P=1/N/PE~220-230V 50-60Hz, R=2/PE~220-240V 50-60Hz, U=1/N/PE~240V 50-60Hz, V=3/PE~240V 50-60Hz, W=1/N/PE~100-110V 50-60Hz

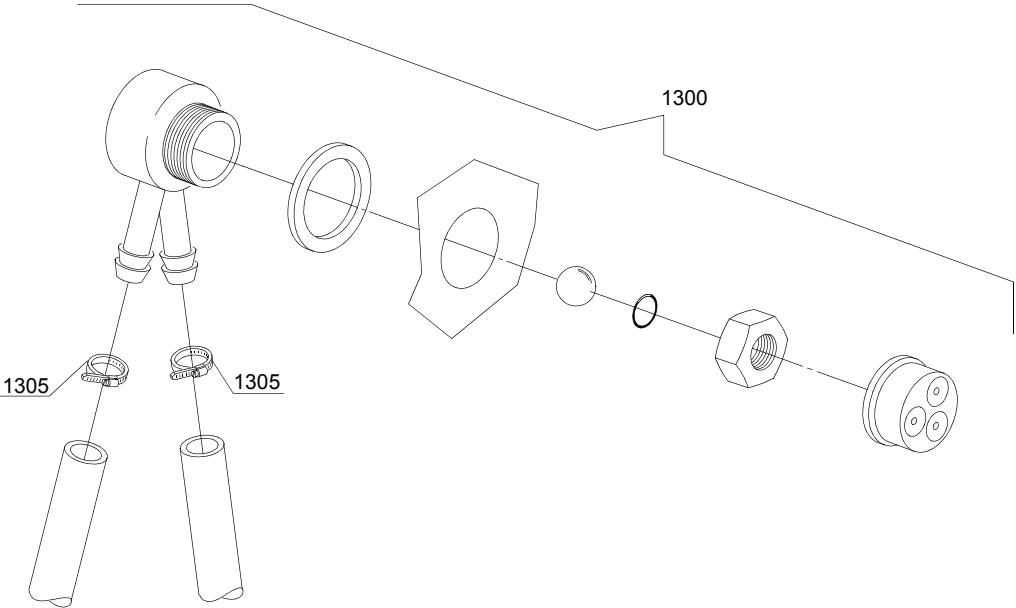

08\_005\_e

## Spare parts

ID	P-code	SN from	SN to	Mod.	Acces.	Volt	Description
<b>Module:DVGW</b>							
1300	999900006		-	e,i	dvgw		DVGW assembly
1305	11807		-	e,i	dvgw		12/22 clamp (minimum 3 pieces)

e=ELECTRONICAL SWITCHES, uw=LOWER AND UPPER WASHING, i=INSULATED MODEL

LUX61=LUX61

bt=BREAK TANK, bp=BOOSTER PUMP, dvgw=DVGW, dd=DETERGENT DISPENSER, dp=DRAIN PUMP

A=3/N/PE~380-400V 50-60Hz, D=3/PE~200-210V 50-60Hz, F=2/PE~220-240V 50-60Hz, G=3/N/PE~415V 50-60Hz, H=3/PE~220-230V 50-60Hz, K=3/PE~380-400V 50-60Hz, L=3/PE~415V 50-60Hz, M=3/PE~440V 60Hz, P=1/N/PE~220-230V 50-60Hz, R=2/PE~220-240V 50-60Hz, U=1/N/PE~240V 50-60Hz, V=3/PE~240V 50-60Hz, W=1/N/PE~100-110V 50-60Hz

10\_001be

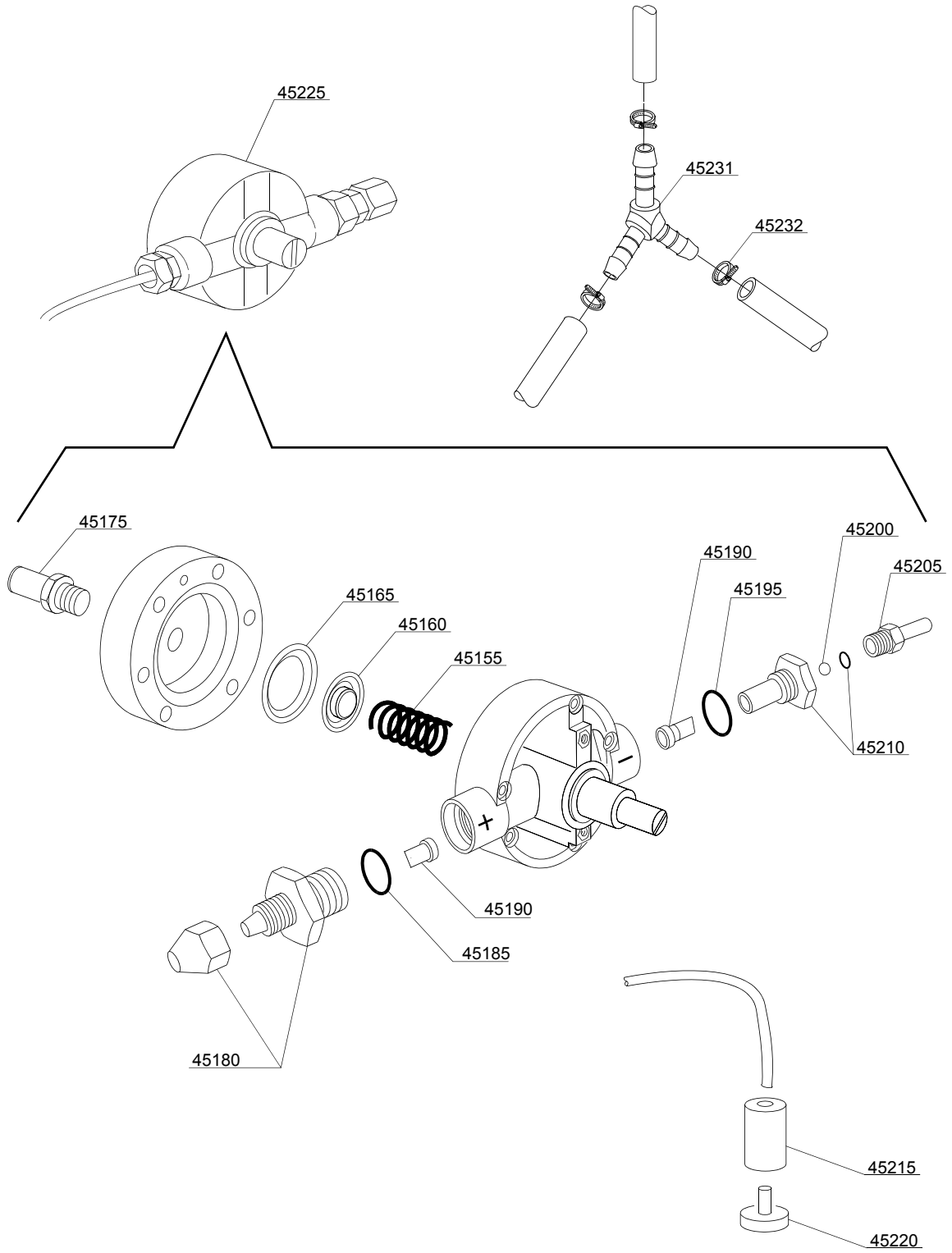

## Spare parts

ID	P-code	SN from	SN to	Mod.	Acces.	Volt	Description
<b>Module: Rinse aid dispenser group</b>							
45155	10705/M		-	e,i			Spring
45160	10705/N		-	e,i			Disc to membrane
45165	10750/O		-	e,i			Membrane
45175	12506		-	e,i			Rubber-holder Ø 10mm
45180	10705/G		-	e,i			Pipe fitting
45185	10705/C		-	e,i			OR-gasket
45190	10705/D		-	e,i			Silicone valve
45195	10705/C		-	e,i			OR-gasket
45200	10705/T		-	e,i			Sphere made of Teflon
45205	10705/R		-	e,i			Brass pipe fitting
45210	10705/E		-	e,i			OR-gasket Guide valve
45215	12525		-	e,i			Ballast
45220	15058		-	e,i			Small filter (minimum 3 pieces)
45225	10799/G		-	e,i			GERMAC rinse aid dispenser
45231	540091		-	e,i			Ø12 mm plastic 3 ways connection
45232	11807		-	e,i			Clamp 12-22 (minimum 3 pieces)

e=ELECTRONICAL SWITCHES, uw=LOWER AND UPPER WASHING, i=INSULATED MODEL

LUX61=LUX61

bt=BREAK TANK, bp=BOOSTER PUMP, dvgw=DVGW, dd=DETERGENT DISPENSER, dp=DRAIN PUMP

A=3/N/PE~380-400V 50-60Hz, D=3/PE~200-210V 50-60Hz, F=2/PE~220-240V 50-60Hz, G=3/N/PE~415V 50-60Hz, H=3/PE~220-230V 50-60Hz, K=3/PE~380-400V 50-60Hz, L=3/PE~415V 50-60Hz, M=3/PE~440V 60Hz, P=1/N/PE~220-230V 50-60Hz, R=2/PE~220-240V 50-60Hz, U=1/N/PE~240V 50-60Hz, V=3/PE~240V 50-60Hz, W=1/N/PE~100-110V 50-60Hz

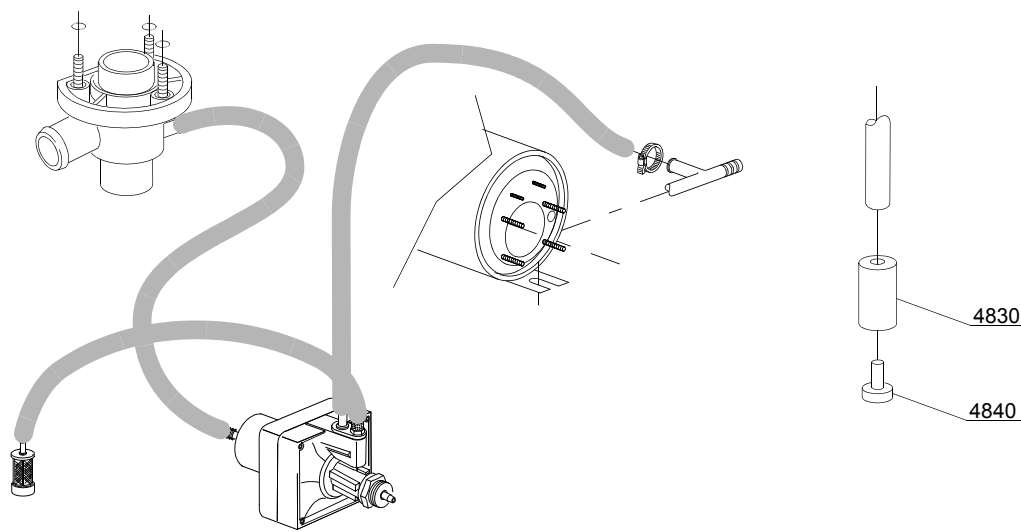
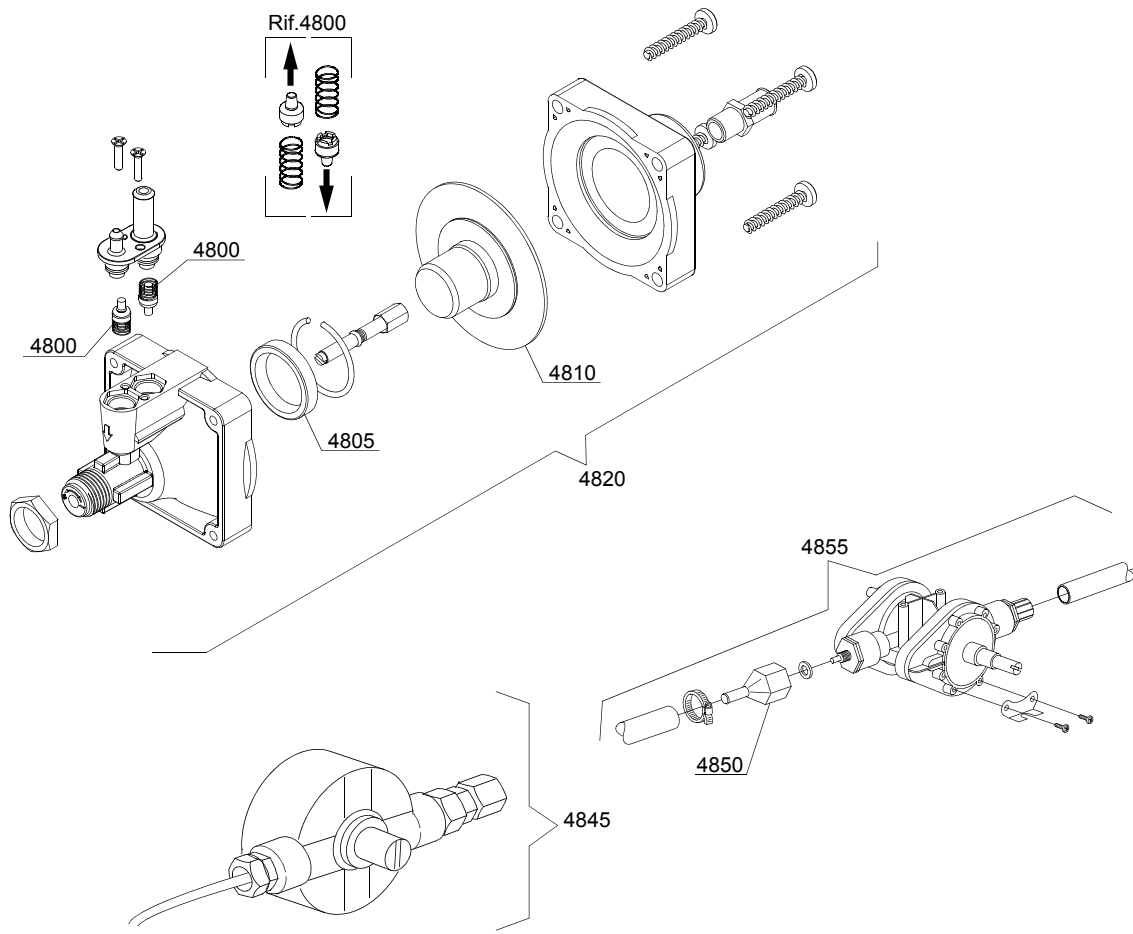

10\_004\_e

## Spare parts

ID	P-code	SN from	SN to	Mod.	Acces.	Volt	Description
<b>Module: Rinse aid dispenser group</b>							
4800	10805		-	e			Tecnopro non return valve
4805	10806		-	e			Ø22 O-ring
4810	10807		-	e			Membrane
4820	10799		-	e			TECNO PRO rinse aid dispenser
4830	12525		-	e			Ballast
4840	15058		-	e			Small filter (minimum 3 pieces)
4845	10799		-	e			GERMAC rinse aid dispenser
4850	10798/B		-	e			Brass pipe fitting
4855	10798		-	e			LANG rinse aid dispenser

e=ELECTRONICAL SWITCHES, uw=LOWER AND UPPER WASHING, i=INSULATED MODEL

LUX61=LUX61

bt=BREAK TANK, bp=BOOSTER PUMP, dvgw=DVGW, dd=DETERGENT DISPENSER, dp=DRAIN PUMP

A=3/N/PE~380-400V 50-60Hz, D=3/PE~200-210V 50-60Hz, F=2/PE~220-240V 50-60Hz, G=3/N/PE~415V 50-60Hz, H=3/PE~220-230V 50-60Hz, K=3/PE~380-400V 50-60Hz, L=3/PE~415V 50-60Hz, M=3/PE~440V 60Hz, P=1/N/PE~220-230V 50-60Hz, R=2/PE~220-240V 50-60Hz, U=1/N/PE~240V 50-60Hz, V=3/PE~240V 50-60Hz, W=1/N/PE~100-110V 50-60Hz

11\_002\_e

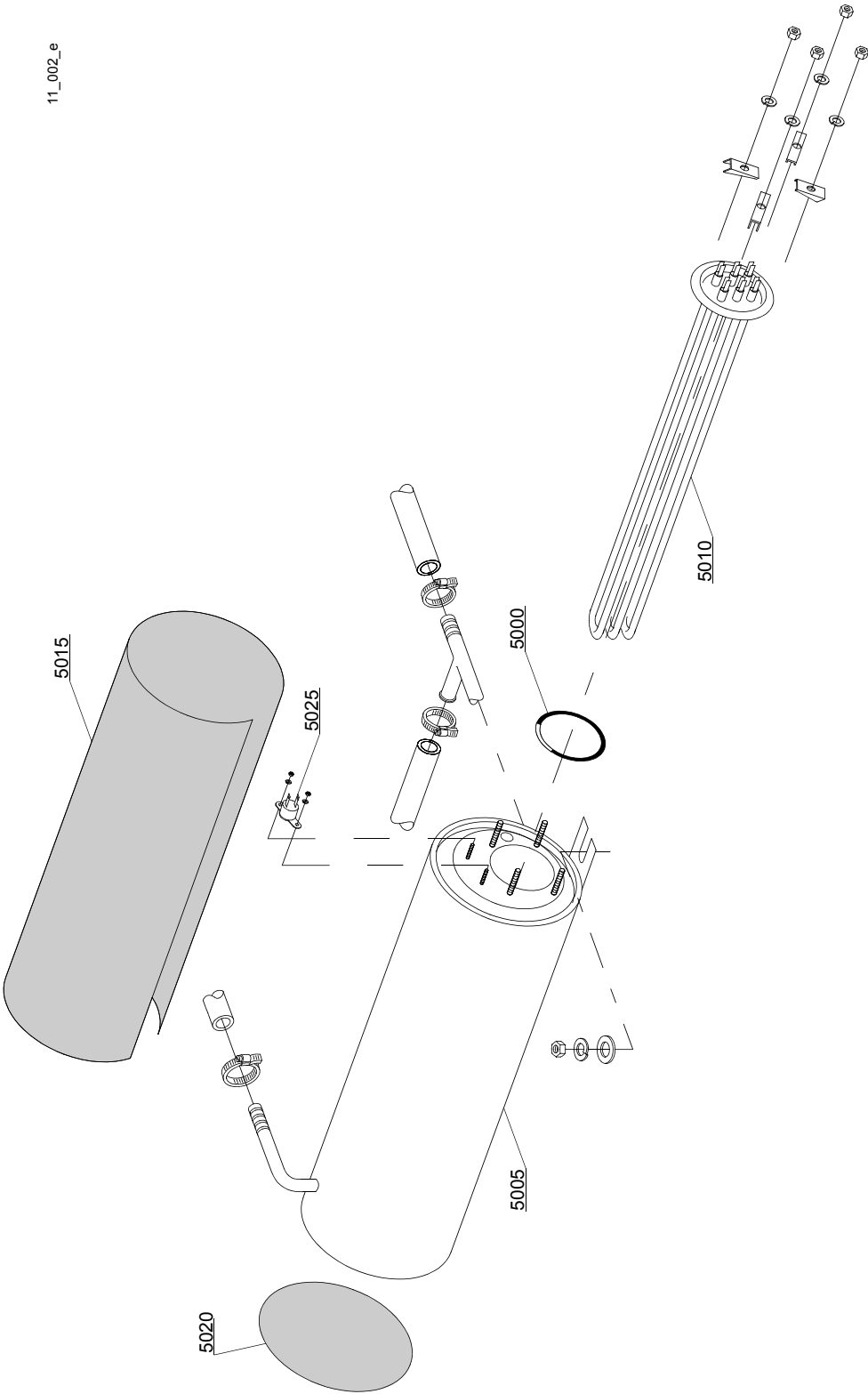

## Spare parts

ID	P-code	SN from	SN to	Mod.	Acces.	Volt	Description
<b>Module:Boiler group</b>							
5000	13005		-	e,i			OR 151 NBR O-ring (minimum 5 pieces)
5005	150905		-	e,i			Boiler
5005	150917		-	e,i			AISI 314 boiler
5010	15089/B		-	e,i			4,5KW heating element - 254/440Vac
5010	15089/E		-	e,i			6/6,53KW - 230/240V 3 heating element
5015	15066		-	e,i			Insulation boiler
5020	15205		-	e,i			Ø160 End piece (minimum 2 pieces)
5025	15550		-	e,i			Safety thermostat

e=ELECTRONICAL SWITCHES, uw=LOWER AND UPPER WASHING, i=INSULATED MODEL

LUX61=LUX61

bt=BREAK TANK, bp=BOOSTER PUMP, dvgw=DVGW, dd=DETERGENT DISPENSER, dp=DRAIN PUMP

A=3/N/PE~380-400V 50-60Hz, D=3/PE~200-210V 50-60Hz, F=2/PE~220-240V 50-60Hz, G=3/N/PE~415V 50-60Hz, H=3/PE~220-230V 50-60Hz, K=3/PE~380-400V 50-60Hz, L=3/PE~415V 50-60Hz, M=3/PE~440V 60Hz, P=1/N/PE~220-230V 50-60Hz, R=2/PE~220-240V 50-60Hz, U=1/N/PE~240V 50-60Hz, V=3/PE~240V 50-60Hz, W=1/N/PE~100-110V 50-60Hz

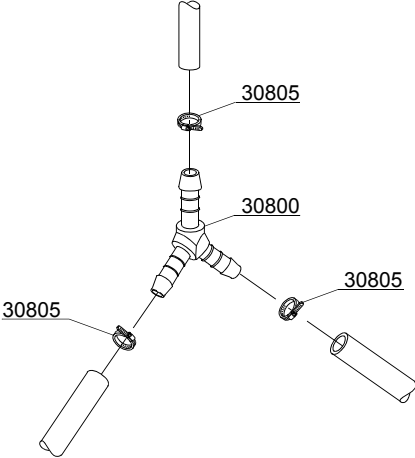

12\_003ae

## Spare parts

ID	P-code	SN from	SN to	Mod.	Acces.	Volt	Description
<b>Module:3 ways connection</b>							
30800	540091		-	e,i			Ø12 mm plastic 3 ways connection
30805	11807		-	e,i			12/22 clamp (minimum 3 pieces)

e=ELECTRONICAL SWITCHES, uw=LOWER AND UPPER WASHING, i=INSULATED MODEL

LUX61=LUX61

bt=BREAK TANK, bp=BOOSTER PUMP, dvgw=DVGW, dd=DETERGENT DISPENSER, dp=DRAIN PUMP

A=3/N/PE~380-400V 50-60Hz, D=3/PE~200-210V 50-60Hz, F=2/PE~220-240V 50-60Hz, G=3/N/PE~415V 50-60Hz, H=3/PE~220-230V 50-60Hz, K=3/PE~380-400V 50-60Hz, L=3/PE~415V 50-60Hz, M=3/PE~440V 60Hz, P=1/N/PE~220-230V 50-60Hz, R=2/PE~220-240V 50-60Hz, U=1/N/PE~240V 50-60Hz, V=3/PE~240V 50-60Hz, W=1/N/PE~100-110V 50-60Hz

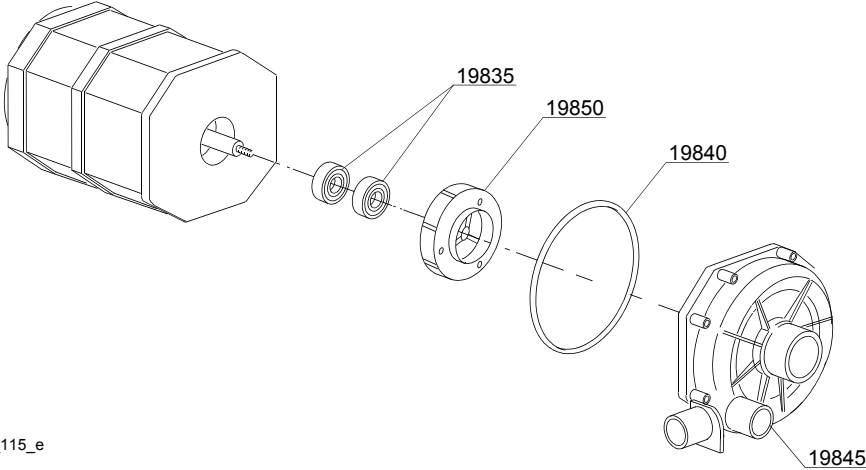
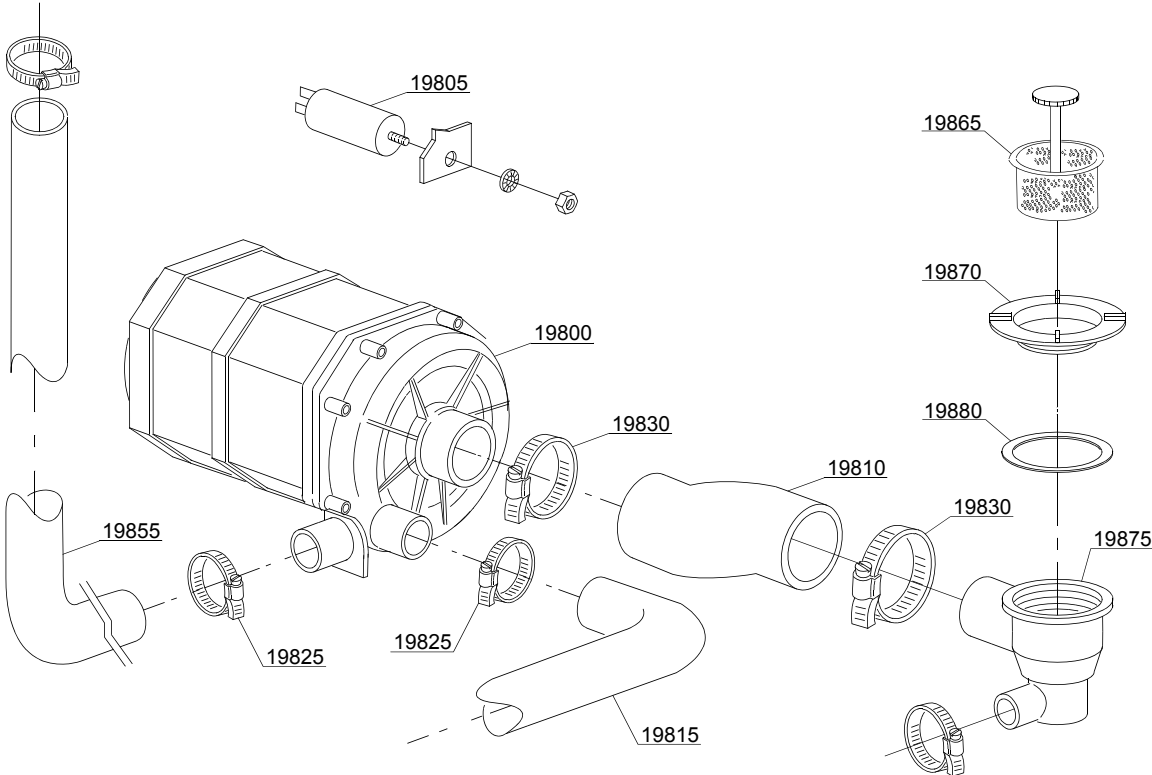

13\_115\_e

## Spare parts

ID	P-code	SN from	SN to	Mod.	Acces.	Volt	Description
<b>Module: Wash pump</b>							
19800	150914		-	uw			0,70Hp wash pump - 230Vac 50Hz
19805	15081		-	uw			12,5 uF condenser
19810	25032/A		-	uw			Suction pipe coupling
19815	561017		-	uw			Low delivery pipe
19825	11806		-	uw			25/40 clamp (minimum 2 pieces)
19830	11809		-	uw			30/45 clamp (minimum 2 pieces)
19835	15080		-	uw			Rotating seals
19840	7130		-	uw			OR pump O-ring (minimum 2 pieces)
19845	16182		-	uw			Scroll
19850	15079/F		-	uw			Pump rotor
19855	561016		-	uw			Top delivery pipe EPDM
19865	561013		-	uw			Pump suction filter
19870	500615		-	uw			Ferrule with filter
19875	500606		-	uw			Right side scrap tray
19880	80208		-	uw			95x75x3 O-ring (minimum 2 pieces)

e=ELECTRONICAL SWITCHES, uw=LOWER AND UPPER WASHING, i=INSULATED MODEL

LUX61=LUX61

bt=BREAK TANK, bp=BOOSTER PUMP, dvgw=DVGW, dd=DETERGENT DISPENSER, dp=DRAIN PUMP

A=3/N/PE~380-400V 50-60Hz, D=3/PE~200-210V 50-60Hz, F=2/PE~220-240V 50-60Hz, G=3/N/PE~415V 50-60Hz, H=3/PE~220-230V 50-60Hz, K=3/PE~380-400V 50-60Hz, L=3/PE~415V 50-60Hz, M=3/PE~440V 60Hz, P=1/N/PE~220-230V 50-60Hz, R=2/PE~220-240V 50-60Hz, U=1/N/PE~240V 50-60Hz, V=3/PE~240V 50-60Hz, W=1/N/PE~100-110V 50-60Hz

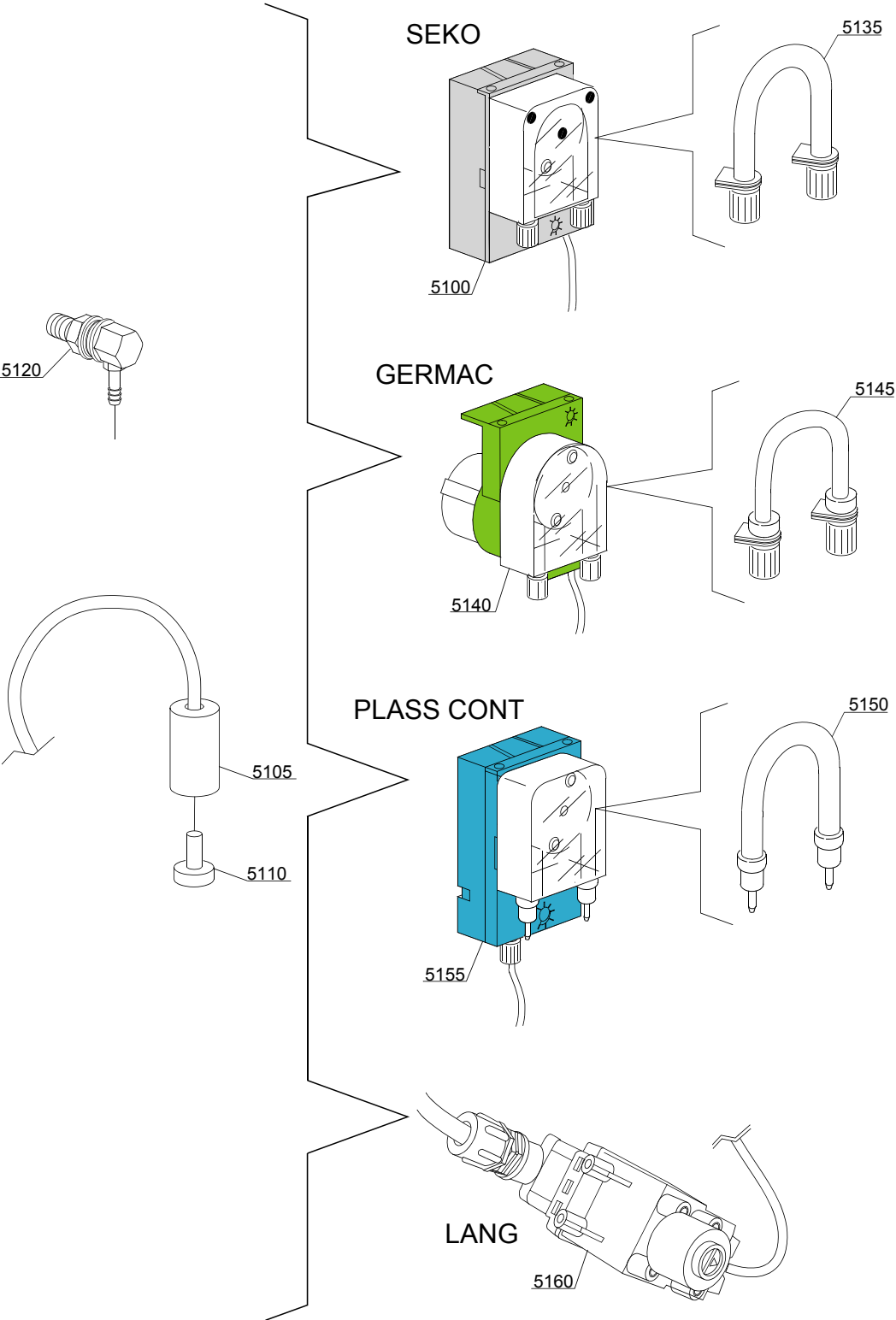

14\_004\_e

## Spare parts

ID	P-code	SN from	SN to	Mod.	Acces.	Volt	Description
<b>Module:Dosing detergent group</b>							
5100	15985		-	i,e	dd		Seko detergent pump
5105	12525		-	i,e	dd		Ballast
5110	15058		-	i,e	dd		Small filter (minimum 3 pieces)
5115	15123		-	i,e	dd		Compleat stainless steel injector
5135	15185		-	i,e	dd		Seko thermoplastic pipe
5140	15985		-	i,e	dd		Germac detergent pump
5145	15108/E		-	i,e	dd		Germac thermoplastic pipe
5150	15985/A			i,e	dd		Plas Cont thermoplastic pipe
5155	15985			i,e	dd		Plas Cont detergent pump
5160	15108/L			i,e	dd		LANG detergent pump

e=ELECTRONICAL SWITCHES, uw=LOWER AND UPPER WASHING, i=INSULATED MODEL

LUX61=LUX61

bt=BREAK TANK, bp=BOOSTER PUMP, dvgw=DVGW, dd=DETERGENT DISPENSER, dp=DRAIN PUMP

A=3/N/PE~380-400V 50-60Hz, D=3/PE~200-210V 50-60Hz, F=2/PE~220-240V 50-60Hz, G=3/N/PE~415V 50-60Hz, H=3/PE~220-230V 50-60Hz, K=3/PE~380-400V 50-60Hz, L=3/PE~415V 50-60Hz, M=3/PE~440V 60Hz, P=1/N/PE~220-230V 50-60Hz, R=2/PE~220-240V 50-60Hz, U=1/N/PE~240V 50-60Hz, V=3/PE~240V 50-60Hz, W=1/N/PE~100-110V 50-60Hz

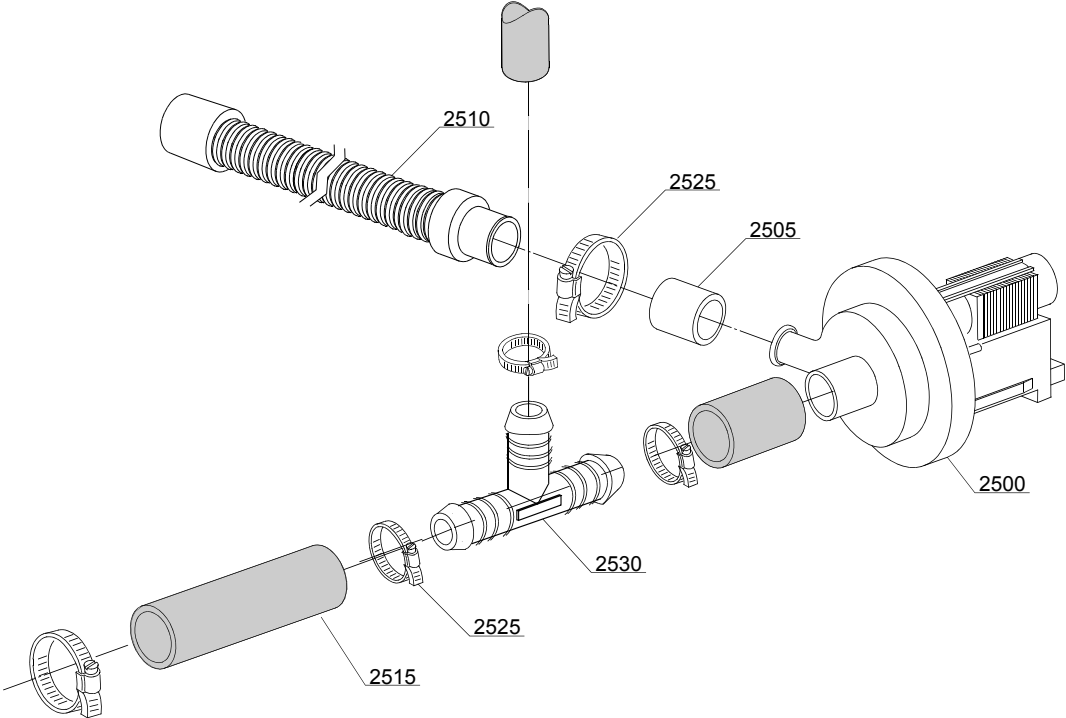

15\_004be

## Spare parts

ID	P-code	SN from	SN to	Mod.	Acces.	Volt	Description
<b>Module:Drain pump group</b>							
2500	15101		-	i,e	dp		Drain pump 220/240V 50Hz
2505	15101/D		-	i,e	dp		Pipe fitting (minimum 3 pieces)
2510	10727		-	i,e	dp		Drain pipe
2515	18044		-	i,e	dp		Ø28 top wash pipe
2525	11806		-	i,e	dp		25/40 clamp (minimum 2 pieces)
2530	540098		-	i,e	dp,bt		D25 3 ways connection for BREAK TANK(bt)

e=ELECTRONICAL SWITCHES, uw=LOWER AND UPPER WASHING, i=INSULATED MODEL

LUX61=LUX61

bt=BREAK TANK, bp=BOOSTER PUMP, dvgw=DVGW, dd=DETERGENT DISPENSER, dp=DRAIN PUMP

A=3/N/PE~380-400V 50-60Hz, D=3/PE~200-210V 50-60Hz, F=2/PE~220-240V 50-60Hz, G=3/N/PE~415V 50-60Hz, H=3/PE~220-230V 50-60Hz, K=3/PE~380-400V 50-60Hz, L=3/PE~415V 50-60Hz, M=3/PE~440V 60Hz, P=1/N/PE~220-230V 50-60Hz, R=2/PE~220-240V 50-60Hz, U=1/N/PE~240V 50-60Hz, V=3/PE~240V 50-60Hz, W=1/N/PE~100-110V 50-60Hz

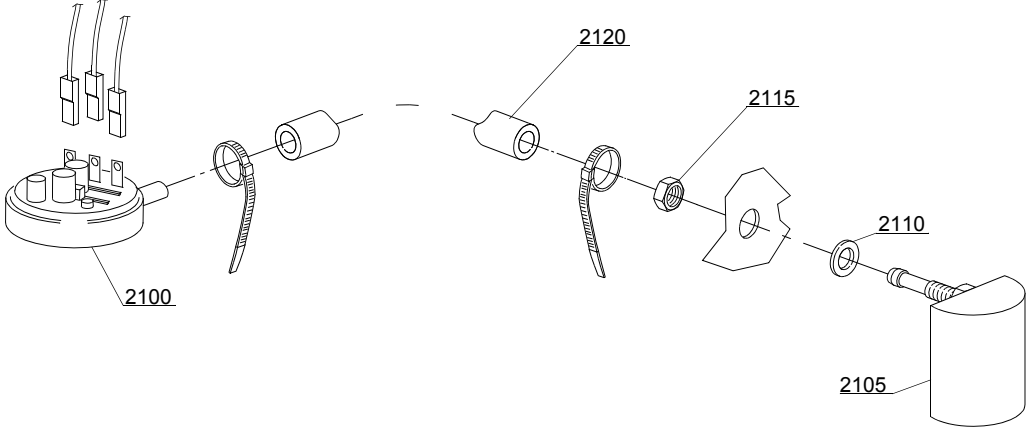

16\_001\_e

## Spare parts

ID	P-code	SN from	SN to	Mod.	Acces.	Volt	Description
<b>Module:Pressure switch group with air trap</b>							
2100	10706/A		-	i,e			47-27 pressure switch
2105	135911/E		-	i,e			Grey air trap assembly
2110	13301		-	i,e			O-ring (minimum 10 pieces) - D14x8x1,5
2115	11702		-	i,e			M8 stainless steel nut (minimum 10 pieces)
2120	14508		-	i,e			4,5X9 EPDM rubber hose (minimum 2mt)

e=ELECTRONICAL SWITCHES, uw=LOWER AND UPPER WASHING, i=INSULATED MODEL

LUX61=LUX61

bt=BREAK TANK, bp=BOOSTER PUMP, dvgw=DVGW, dd=DETERGENT DISPENSER, dp=DRAIN PUMP

A=3/N/PE~380-400V 50-60Hz, D=3/PE~200-210V 50-60Hz, F=2/PE~220-240V 50-60Hz, G=3/N/PE~415V 50-60Hz, H=3/PE~220-230V 50-60Hz, K=3/PE~380-400V 50-60Hz, L=3/PE~415V 50-60Hz, M=3/PE~440V 60Hz, P=1/N/PE~220-230V 50-60Hz, R=2/PE~220-240V 50-60Hz, U=1/N/PE~240V 50-60Hz, V=3/PE~240V 50-60Hz, W=1/N/PE~100-110V 50-60Hz

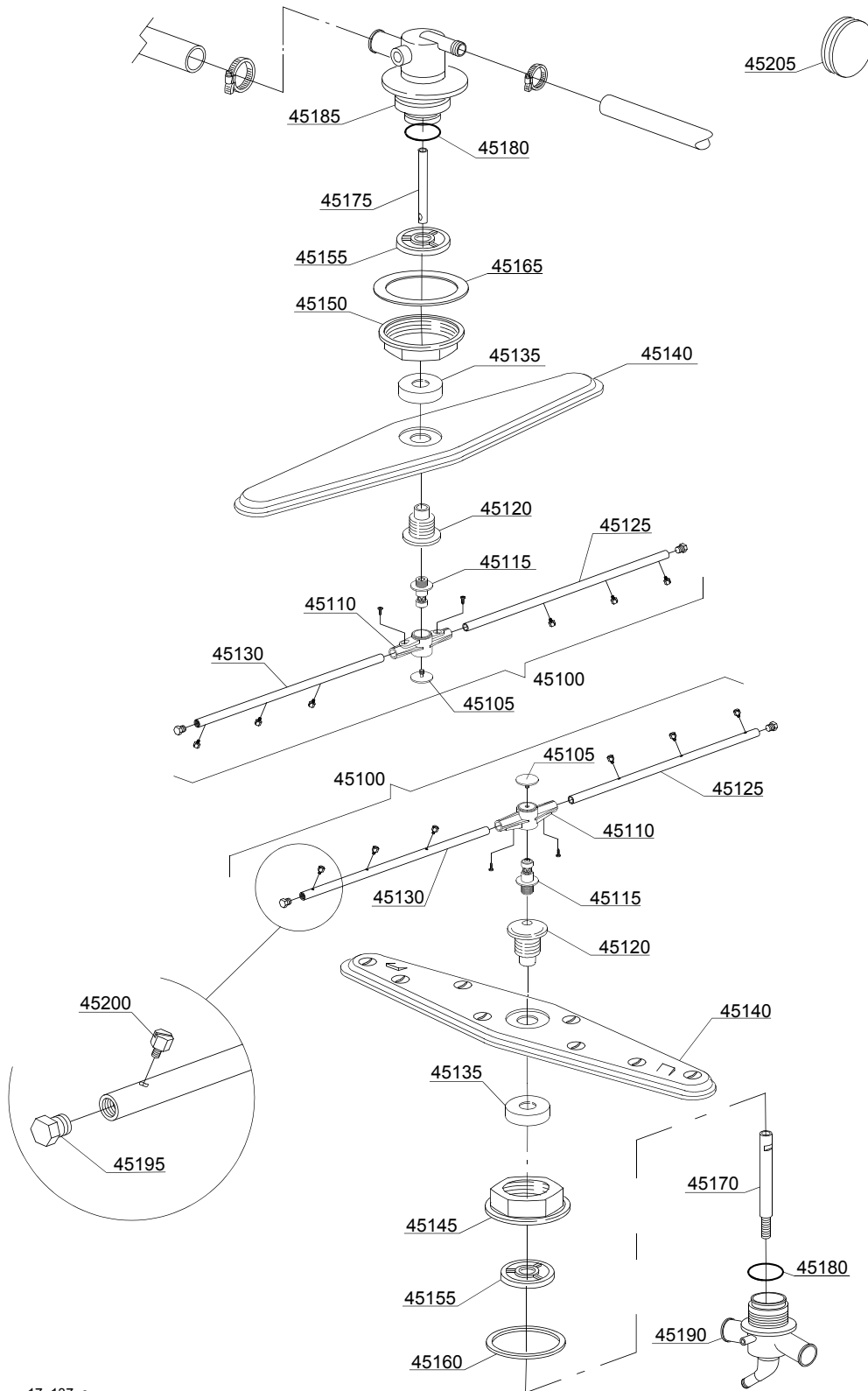

17\_137\_e

## Spare parts

ID	P-code	SN from	SN to	Mod.	Acces.	Volt	Description
<b>Module:Turret group with rotating arms</b>							
45100	75918		-	uw,e			Top/lower rinse arm complete
45105	10652		-	uw,e			Rinse arm screw
45110	10650		-	uw,e			Rinse arm
45115	10651		-	uw,e			Rinse axle
45120	500701		-	uw,e			Hub for rotor (inox rinse arm)
45125	10657		-	uw,e			Right rinse arm - stainless steel nozzle
45130	10658		-	uw,e			Left rinse arm - stainless steel nozzle
45135	500702		-	uw,e			Nut for wash arm bearing 05 (inox rinse arm)
45140	500700		-	uw,e			Stainless steel wash rotor
45145	540069		-	uw,e			Turret fixing nut
45150	540093		-	uw,e			Nut for top turret fixing
45155	540076		-	uw,e			Guide pipe
45160	540034		-	uw,e			Plain O-ring
45165	540032		-	uw,e			Plain O-ring (minimum 2 pieces)
45170	561032		-	uw,e			Upper stainless steel wash rotor rinse axle AP
45175	561034		-	uw,e			Under stainless steel wash rotor rinse axle AP
45180	561035		-	uw,e			AP seal ring
45185	561033		-	uw,e			AP top turret stainless steel wash rotor
45190	561031		-	uw,e			AP under turret stainless steel wash rotor
45195	560017		-	uw,e			Stainless steel rinse nozzle
45200	560018		-	uw,e			Rinse arm plug
45205	13316/A		-	uw,e			DVGW hole O-ring

e=ELECTRONICAL SWITCHES, uw=LOWER AND UPPER WASHING, i=INSULATED MODEL

LUX61=LUX61

bt=BREAK TANK, bp=BOOSTER PUMP, dvgw=DVGW, dd=DETERGENT DISPENSER, dp=DRAIN PUMP

A=3/N/PE~380-400V 50-60Hz, D=3/PE~200-210V 50-60Hz, F=2/PE~220-240V 50-60Hz, G=3/N/PE~415V 50-60Hz, H=3/PE~220-230V 50-60Hz, K=3/PE~380-400V 50-60Hz, L=3/PE~415V 50-60Hz, M=3/PE~440V 60Hz, P=1/N/PE~220-230V 50-60Hz, R=2/PE~220-240V 50-60Hz, U=1/N/PE~240V 50-60Hz, V=3/PE~240V 50-60Hz, W=1/N/PE~100-110V 50-60Hz