

Lavastoviglie professionali di lunga durata

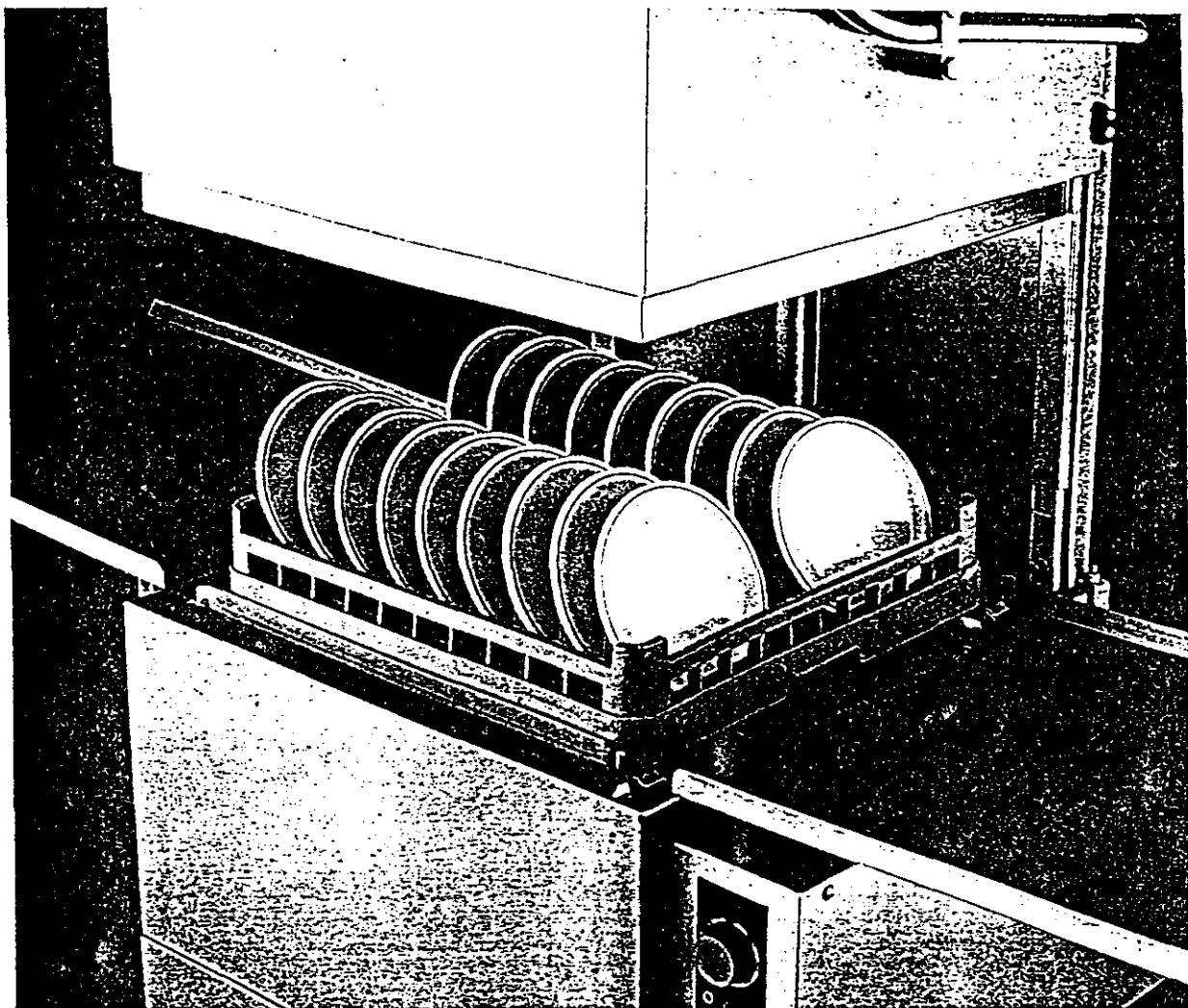

Serie C

Modello C33 (860 piatti/ora)

sicure
perché garantite e collaudate
una per una da Comenda

Modello C34 (1080 piatti/ora)

instancabili
e veloci per l'uso di componenti
di prima qualità ad alta tecnologia



L'alta professionalità del lavaggio.

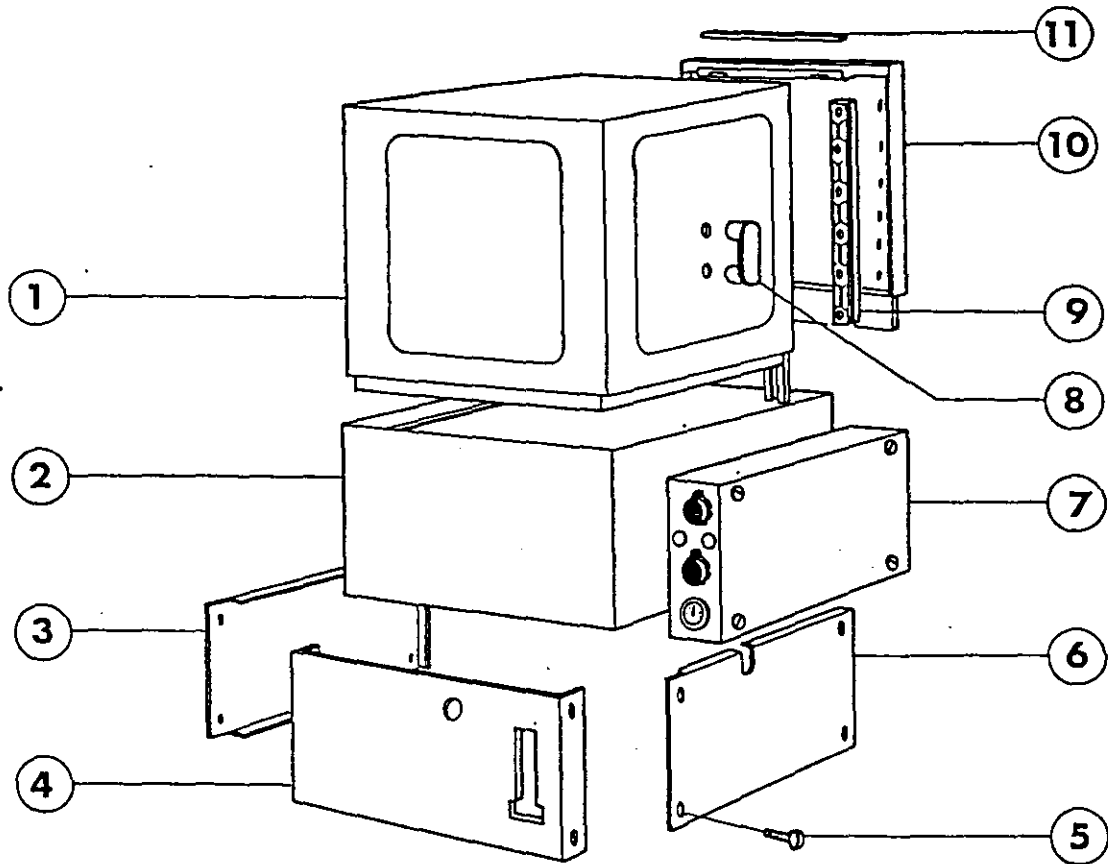

Pos.	Codice	Denominazione	Denomination	Description	Bezeichnung
1	340142	Capot	Capote	Hood	Gehäuse
2	340851	Vasca	Cuve	Tank	Tank
3	350265	Pannello lat. sinistro	Panneau lateral g.	Side panel left	Seitliche Abdeckung links
4	350171	Pannello frontale	Panneau frontal	Front panel	Frontplatte
5	260223	Viti spec. M5x12	Vis M5x12	Screw M5x12	Schraube M5x12
6	350264	Pannello laterale des.	Panneau lateral d.	Side panel right	Rechte Abdeckung
7	110130	Cassetta elettrica	Boite électrique	Control cabinet	Elektro-Schaltkassette
7	110134	Cassetta elett. vapore	Boite électrique vap.	" " steam vers.	E-Tafel Dampfzuführung
8	190608	Cavallotto	Guide	Support	Führung
9	180604	Guide	Rail	Guide	Führung
10	340312	Pannello posteriore	Panneau posterieur	Back panel	Rückwand
11	200432	Guarnizione	Joint	Gasket	Dichtung

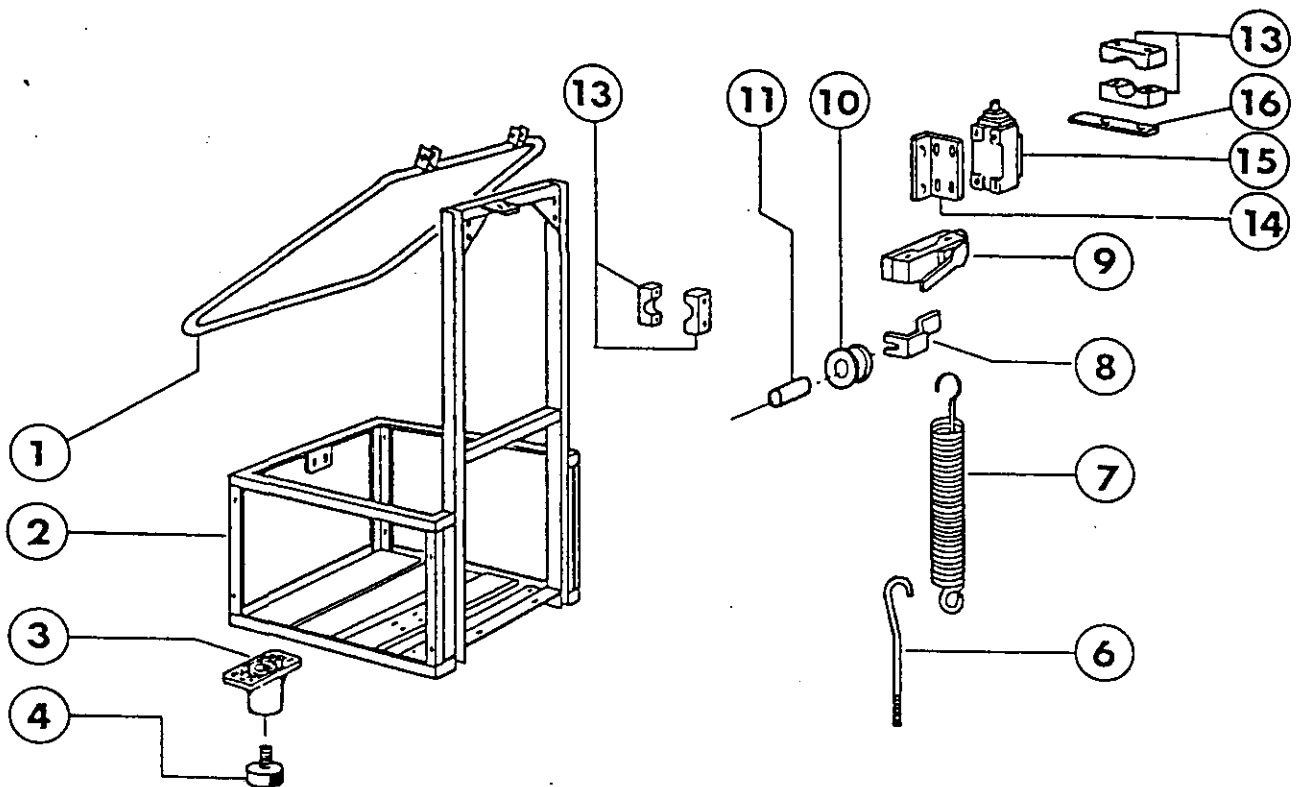

Pos	Codice	Descrizione	Denomination	Description	Bezeichnung
1	331007	Maniglione	Poignée	Door lever	Griff
2	390272	Telaio	Chassis	Frame	Rahmen
3	160509	Supporto piede	Support	Support	Halterung
4	210203	Piedino gomma	Pied	Rubber foot	Fuss
6	330207	Tirante	Tirant	Tie rod	Zugstange
7	391313	Molla	Ressort	Spring	Feder
8	350735	Squadretta premim.	Equerre	Bracket	Winkel
9	120319	Microinterruttore	Micro interrupteur	Microswitch	Endschalter
10	190616	Bussola	Douille	Roller	Buchse
11	330816	Bussola acciaio	Douille	Bushing	Buchse
13	440703	Supporto maniglione	Support poignée	Block	Halterung
14	350742	Squadretta micro	Equerre	Bracket	Winkel
15	120322	Microinterrut.pizz.	Micro interrupteur	Microswitch	Endschalter
16	320644	Piastra premimicro	Patte	Plate	Platte

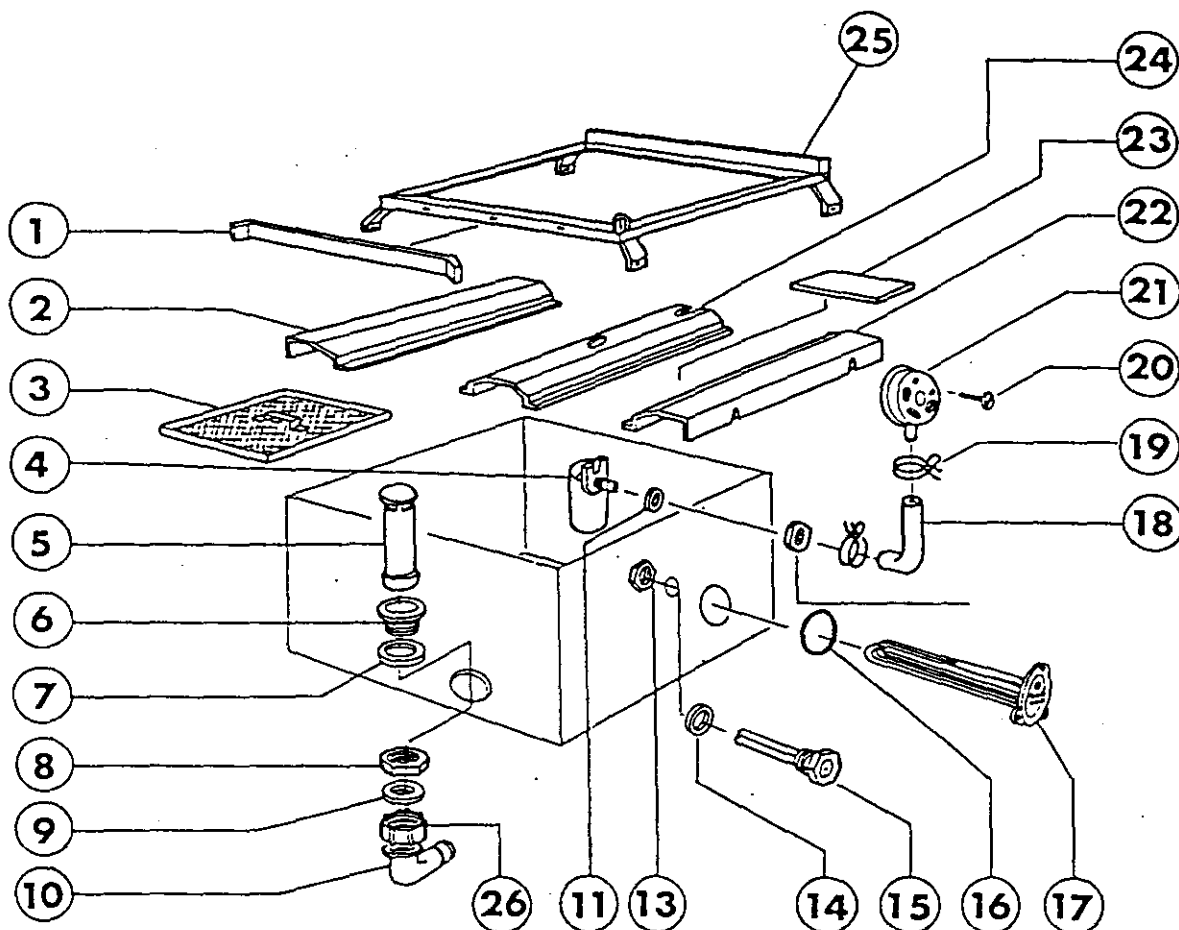

Pos	Codice	Descrizione	Denomination	Description	Bezeichnung
1	320892	Spalla mobile	Rail	Removable guide	Korbführung
2	321005	Trav.portafilt.sx	Rail gauche	Filler	Filterhalterung
3	180811	Filtro a cestello	Filtre	Screen	Filter
4	161301	Trappola aria	Capuchon air	Air chamber	Luftfalle
5	180703	Troppopieno	Trop plein	Overflow pipe	Überlaufstutzen
6	160305	Piletta scarico	Bonde de vidange	Drain outlet	Ablaufstutzen
7	200410	Guarnizione pilet.	Joint	Gasket	Dichtung
8	180109	Ghiera per pilet.	Embout	Lock nut	Klemmring
9	200412	Guarnizione codulo	Joint	Gasket	Dichtung
10	160202	Codulo curvo	Douille	Drain ell	Ablauf
11	200415	Guarnizione	Joint	Gasket	Dichtung
13	270101	Controdado 1/2"	Contre ecrous	Lock nut	Gegenmutter
14	460502	Guarniz.amiantite	Joint	Gasket	Dichtung
15	450514	Guaina doppia	Gaine thermostat	Thermostat shield	Schutzhülle thermostat
16	200815	OR	O-Ring	O-Ring	O-Ring
17	110226	Resistenza	Résistance	Heating element	Heizkörper
18	200353	Tubo pressostato	Tuyau pressostat	Press.switch hose	Druckwächterschlauch
19	450125	Molle	Ressort	Spring	Feder
20	260701	Vite autofilettant.	Vis	Screw	Schraube
21	130604	Pressostato	Pressostat	Pressure switch	Druckwächter
22	321004	Trav.portafiltro sx	Rail droite	Filler	Filterhalterung
23	321009	Traversino	Plaquette	Filler	Querstück
24	321003	Traversa centrale	Rail central	Filler	Zentralhalterung
25	320891	Telaio portacest.	Chassis porte pan.	Track	Führung
26	180102	Ghiera codulo	Embout	Lock nut	Klemmring

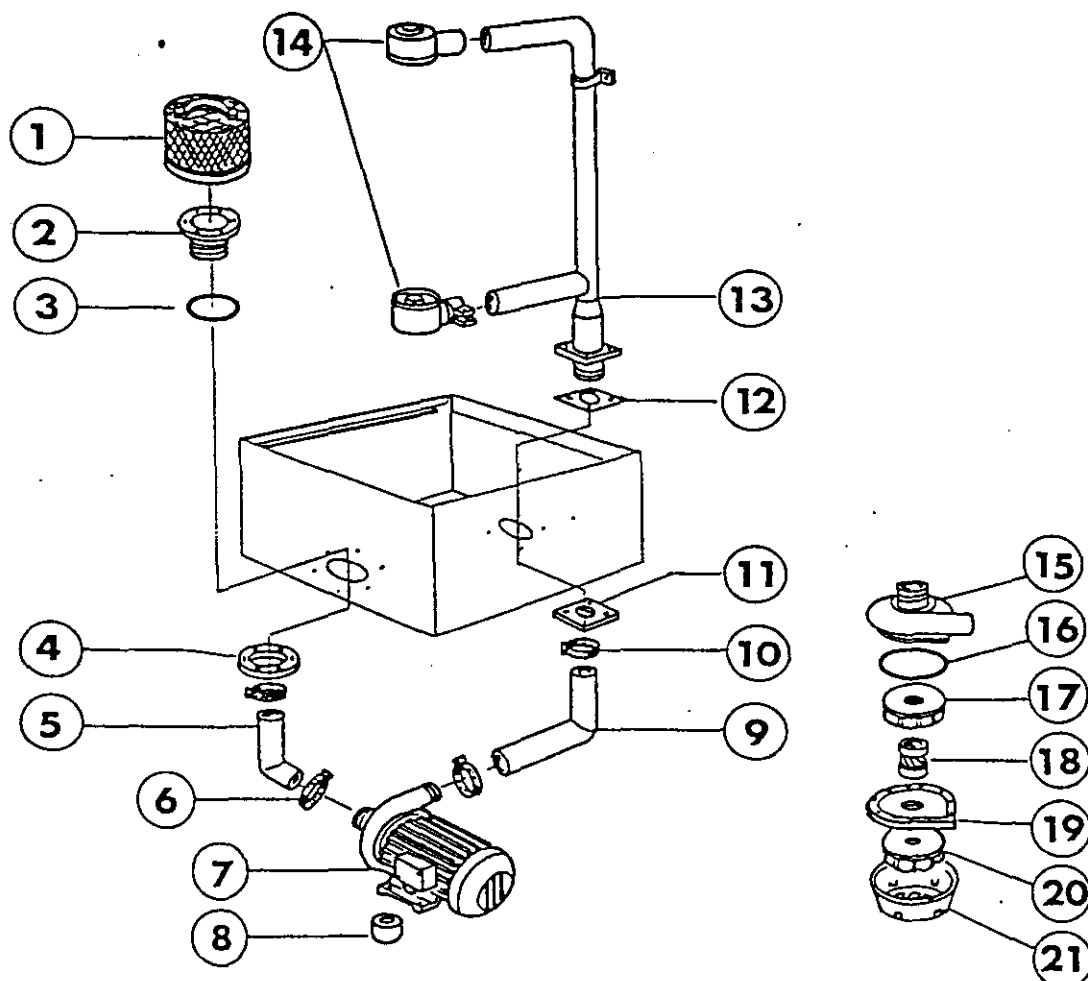

Pos	Codice	Denominazione	Denomination	Description	Bezeichnung
1	330528	Filtro Ø 195	Filtre Ø 195	Strainer Ø 195	Filter Ø 195
2	180207	Tronchetto aspiraz.	Tronc Aspiration	Suction flange	Ansaugstutzen
3	200807	OR	O-Ring	O-Ring	O-Ring
4	180204	Controflangia	Contreflasque	Flange	Gegenflansch
5	200359	Tubo aspirazione	Tuyau aspiration	Suction hose	Ansaugrohr
6	450127	Fascetta Ø 68+85	Collier Ø 68+85	Clamp Ø 68-85	Schlauchschelle Ø68+85
7	100361	Pompa HP2	Motopompe HP 2	Motor pump HP 2	Pumpe 2 PS
8	210202	Piedini	Pied	Rubber foot	Fuss
9	200315	Tubo mandata	Coude	Discharge hose	Druckstutzen
10	450119	Fascetta	Collier	Clamp	Schlauchschelle
11	380904	Controflangia	Contre flasque	Flange	Gegenflansch
12	200423	Guarnizione	Joint	Gasket	Dichtung
13	420304	Tubo lavaggio	Tuyau lavage	Stand pipe	Ob.Waschrohr
14	510238	Supporto mulinello	Support tourniquet	Wash adaptor	Wascharmhalterung
15	630114	Chiocciola	Escargot pompe	Pump housing	Pumpengehause
16	630411	OR	O-Ring	O-Ring	O-Ring
17	631618	Girante	Turbine	Impeller	Lauftrad
18	630501	Tenuta frontale	Joint presse ét.	Seal	Mech.Dichtung
19	630223	Flangia	Flasque	Pump backplate	Flansch
20	630306	Ventola raffreddamento	Turbine	Pump fan	Lauftrad
21	630216	Coperchio per ventola	Couvercle	Back cover	Deckel

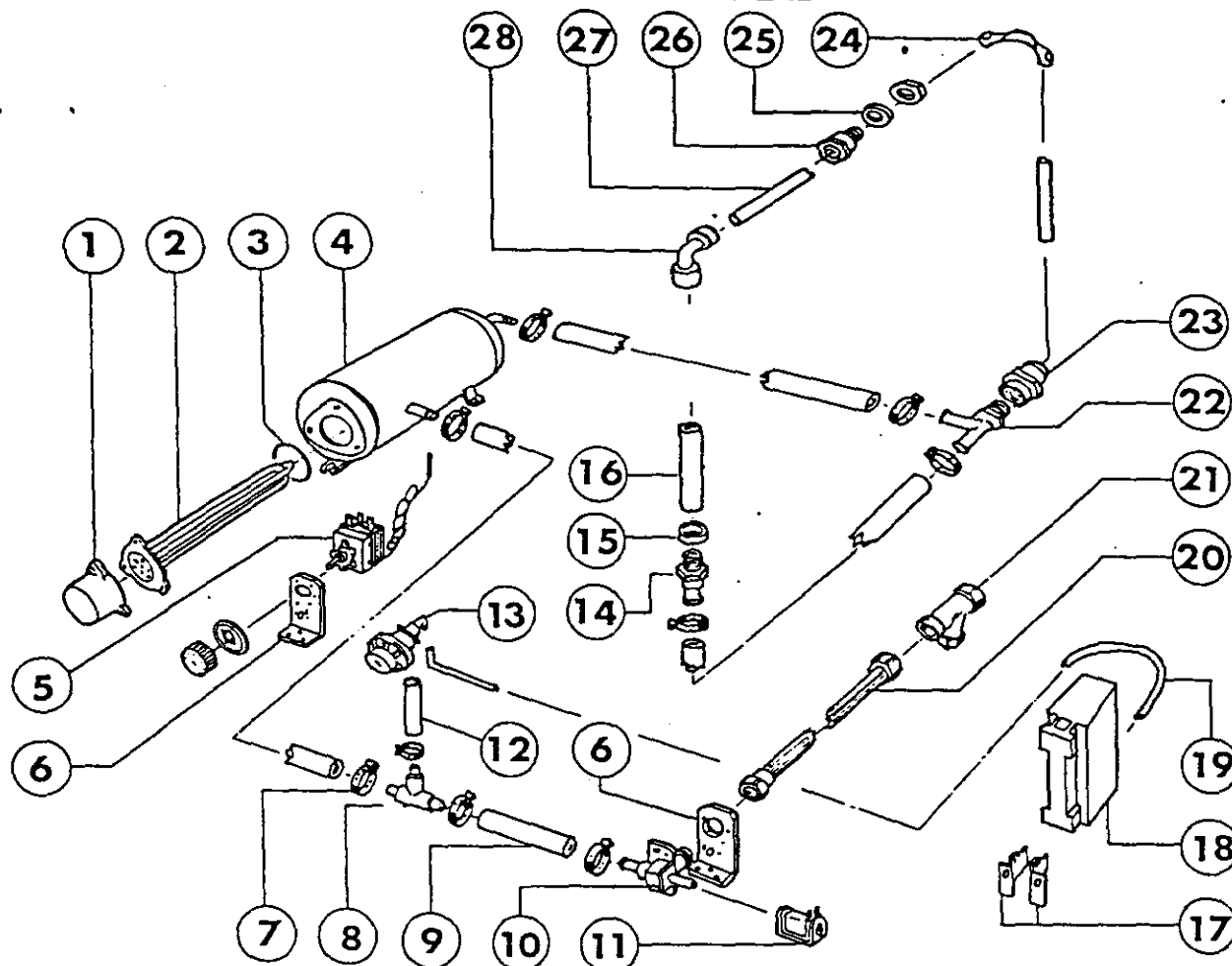

Pos	Codice	Descrizione	Denomination	Description	Bezeichnung
1	161102	Copriresistenza	Protection résist.	Heater cover	Heizkörperschutz
2	110349	Resistenza	Résistance	Heater	Heizkörper
3	200815	OR	O-Ring	O-Ring	O-Ring
4	330307	Boiler	Surchauffeur	Booster	Durchlauferhitzer
5	120501	Termostato	Thermostat	Thermostat	Thermostat
6	330725	Squadretta unific.	Equerre	Bracket	Winkel
7	450104	Fascetta Ø 16+28	Collier Ø 16+28	Clamp Ø 16+28	Schelle Ø 16+28
8	180408	TE per dosatore	TE pour doseur	TEE	T-Stück Dosierung
9	200113	Tubo gomma Ø 12+22	Durite Ø 12+22	Rubber hose Ø12-22	Gummischlauch Ø12-22
10	120145	Elettrovalvola	Électrovanne	Solenoid valve	E-Ventil
11	630969	Bobina	Bobine	Coil	Spule
12	200373	Tubo gomma Ø 7x16	Durite Ø 7x16	Rubber hose Ø 7x16	Gummischlauch Ø7x16
13	620120	Dosatore	Doseur	Rinse injector	Glanzmitteldosierer
14	290407	Portagomma 3/8"	Raccord 3/8"	Nipple 3/8"	Nippel 3/8"
15	460501	Guarnizione amiant.	Joint	Gasket	Dichtung
16	331327	Tubo risc.inferior.	Tuyau rinçage	Rinse hose	Nachspülrohr
17	350745/6	Squadretta	Equerre	Bracket	Winkel
18	190804	Contentitore brillan.	Container prod.rin	Rinse aid container	Glanzmittelbehälter
19	160105	Tubo aspiraz.dosat.	Tuyau asp.doseur	Injector inlet tube	Ansaugschlauch
20	200715	Tubo carico	Tuyau	Fill hose	Einlaufschlauch
21	620209	Filtro entrata acqua	Filtre	Strainer	Filter
22	190311	Raccordo risciacqu	Raccord	TEE	Anschluss
23	290216	Attacco Ø12 1/2"	Raccord	Hose clamp	Schlauchklemme
24	390623	Curva reggitubo	Plaque	Hose support	Halterung
25	200819	Guarnizione OR	O-Ring	O-Ring	O-Ring
26	150811	Pressacavo	Protection gaine	Strain relief	Kabeldurchlass
27	160113	Tubo Ø12 polietilene	Durite Ø12	Plastic tube Ø12	Gummischlauch Ø12
28	290217	Attacco Ø 12x3/8"	Raccord	Elb connector	Schlauchklemme Ø22

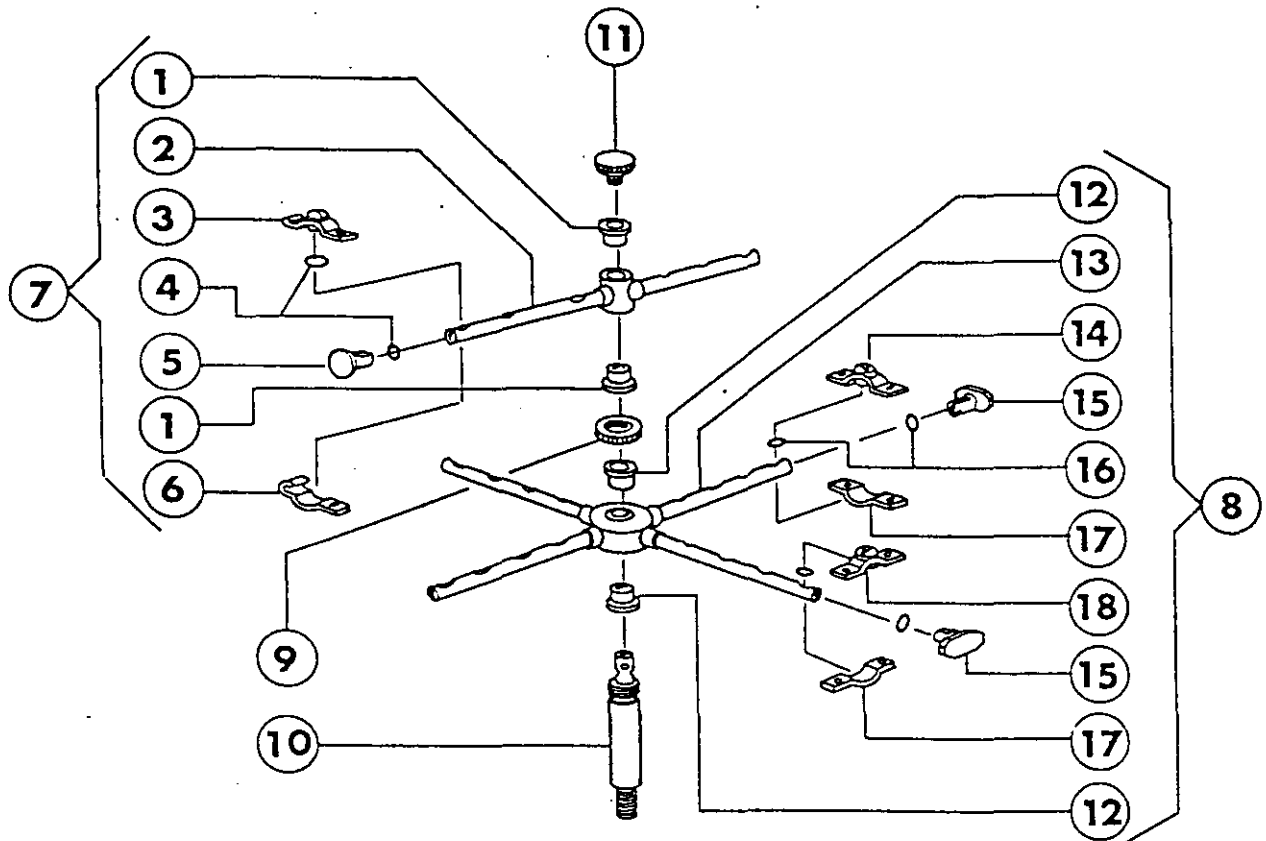

Pos.	Codice	Denominazione	Denomination	Description	Bezeichnung
1	190615	Bussole mulinello risc.	Douille	Bearing	Lagerbuchse
2	430307	Mulinello saldato	Tourniquet	Rinse arm	Nachspüllarm
3	170911	Ugello di risciacquo	Gicleur rinçage	Rinse nozzle top	Spüldüse
4	200818	OR	O-Ring	O-Ring	O-Ring
5	160718	Tappo per mulinello	Bouchon	End plug	Verschluss
6	170704	Cavallotto x ugello	Etrier	Rinse nozzle bottom	Halterung Nachspüldüse
7	430308	Mulinello risc. compl.	Tourniquet rinçage	Rinse arm assembly	Nachspüllarm
8	420511	Mulinello lav. compl.	Tourniquet lavage	Wash arm assembly	Wascharm
9	280409	Ghiera bloccaggio	Embout	Lock nut	Klemmring
10	340499	Alberino	Axe	Spindle	Welle
11	261004	Vite bloccaggio	Vis	Cap screw	Schraube
12	190614	Bussola mulin. lavag.	Douille	Bearing	Lagerbuchse
13	420509	Mulinello saldato	Tourniquet	Wash arm	Wascharm
14	170917	Getto a destra	Jet droite	Wash noz.top right	Düse rechts
15	160719	Tappo	Bouchon	End plug	Propfen
16	200824	OR	O-Ring	O-Ring	O-Ring
17	180213	Flangia bloccag.getti	Flasque	Wash nozzle bottom	Halterung Waschdüse
18	170918	Getto a sinistra	Jet gauche	Wash noz.top left	Düse links

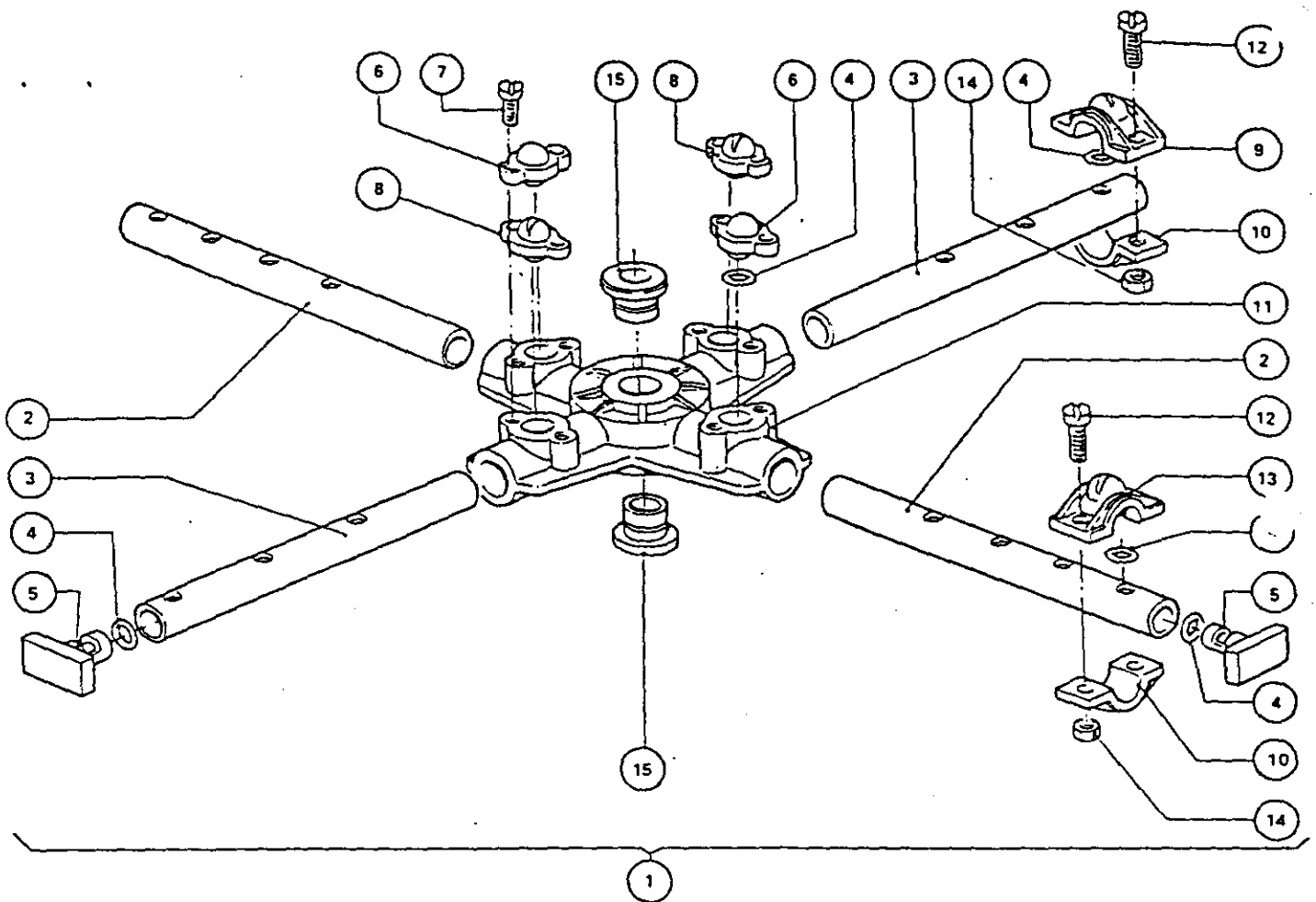

POS.	N. CODICE	DESCRIZIONE	DENOMINATION	DESCRIPTION	BEZEICHNUNG
1	420511 ✓	MULINELLO COMPLETO	TOURNIQUET COMPL.	WASH-RINSE ARM	SPULARM
2	331359 ✓	TUBO LAVAGGIO	TUYAU LAVAGE	WASH PIPE	WASCHROHR
3	331360 ✓	TUBO LAVAGGIO	TUYAU LAVAGE	WASH PIPE	WASCHROHR
4	200824 ✓	GUARNIZIONE OR	JOINT OR	O-RING	O-RING
5	160719 ✓	TAPPO LAVAGGIO	BOUCHON	PLUG WASH ARM	PROFFEN
6	170928 ✓	UGELLO LAV. CIECO	GICLEUR LAVAGE	BLIND-JET	BLINDDUSE
7	260207 ✓	VITE	VIS	SCREW	SCHRAUBE
8	170927 ✓	UGELLO LAVAGGIO	GICLEUR LAVAGE	WASH-JET	WASCHDUSE
9	170917 ✓	GETTO DESTRO	JET DROITE	RIGHT JET	RECHTE DUSE
10	180213 ✓	FLANGIA BLOCC. GETTI	FLASQUE	JET LOCKING	DUSENKLEMMUNG
11	191027 ✓	CORPO MULINELLO	CORPS TOURNIQUET	CENTRAL CROSS	SPULARMKREUZ
12	260226 ✓	VITE	VIS	SCREW	SCHRAUBE
13	170918 ✓	GETTO SINISTRO	JET GAUCHE	LEFT JET	LINKE DUSE
14	260402 ✓	DADO M4	ECROU M4	NUT	MUTTER
15	190621 ✓	BUSSOLA	DOUILLE	BUSH	BUCHSE

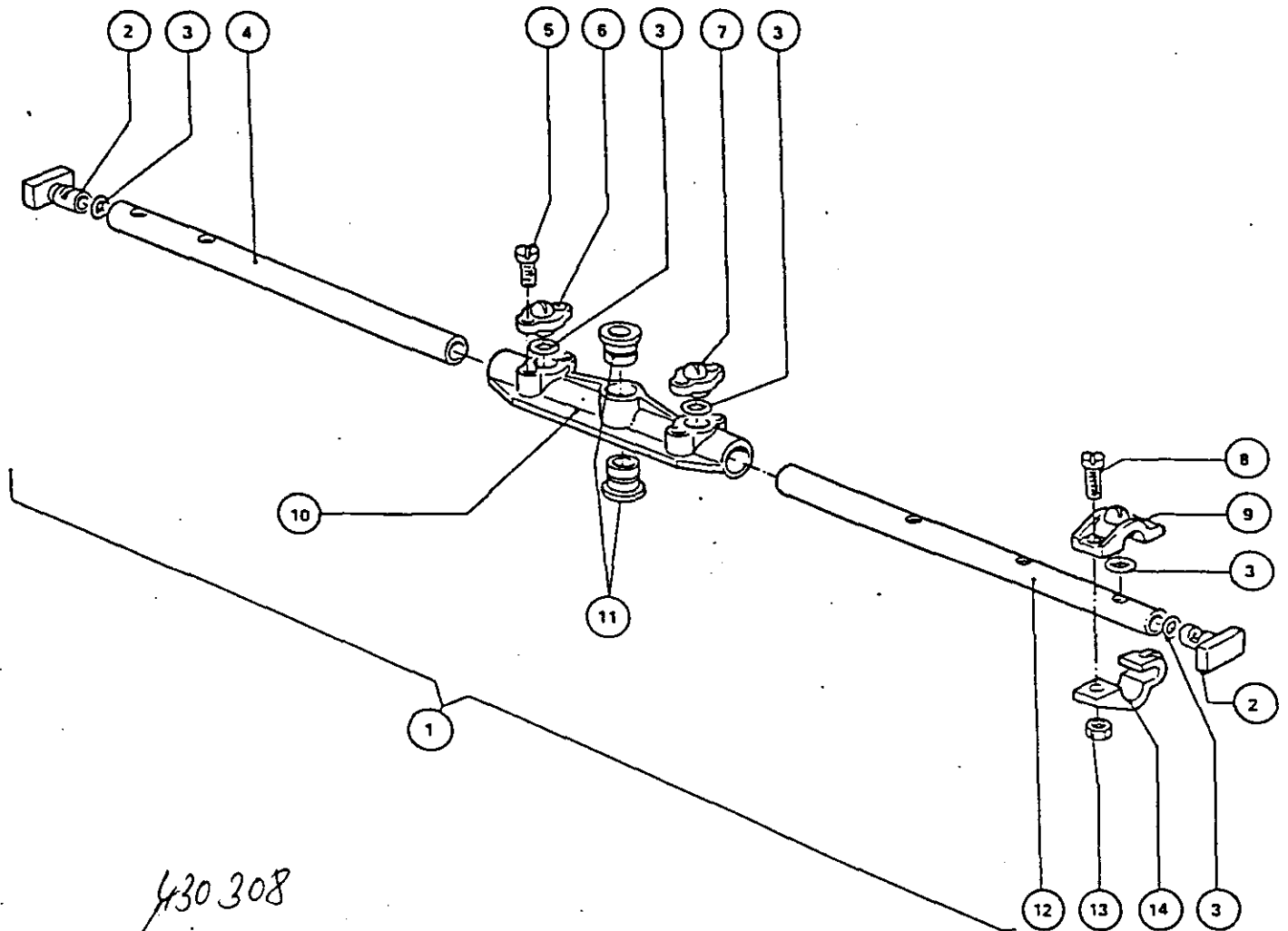

POS.	N. CODICE	DESCRIZIONE	DENOMINATION	DESCRIPTION	BEZEICHNUNG
1	30645 430308	MULINELLO COMPLETO	TOURNIQUET COMPL.	WASH-RINSE ARM	SPULARM
2	160718 ✓	TAPPO RISCIAQUO	BOUCHON RINCAGE	PLUG RINSE ARM	PROPFEN
3	200818 ✓	GUARNIZIONE OR	JOINT OR	O-RING	O-RING
4	331362 ✓	TUBO RISCIAQUO	TUYAU RINCAGE	RINSE PIPE	NACHSPULROHR
5	260207 ✓	VITE	VIS	SCREW	SCHRAUBE
6	170929 ✓	UGELLI RISCIAQUO	GICLEUR RINCAGE	RINSE JET	NACHSPULDOUSE
7	170930 ✓	UGELLI RISC. CIECO	GICLEUR RINCAGE	BLIND-JET	BLINDDOUSE
8	260226 ✓	VITE	VIS	SCREW	SCHRAUBE
9	170911 ✓	UGELLO RISCIAQUO	GICLEUR RINCAGE	RINSE JET	NACHSPULDOUSE
10	191030 ✓	CORPO MULINELLO	CORPS TOURNIQUET	CENTRAL CROSS	SPULARMKREUZ
11	190617 ✓	BUSSOLA	DOUILLE	BUSH	BUCHSE
12	331361 ✓	TUBO RISCIAQUO	TUYAU RINCAGE	RINSE PIPE	NACHSPULROHR
13	260402 ✓	DADO M4	ECROU M4	NUT	MUTTER
14	170704 ✓	CAVALLOTTO FIS. GETT.	ETRIER	RINSE NOZZLE	NACHSPULDOUSENHALTERU

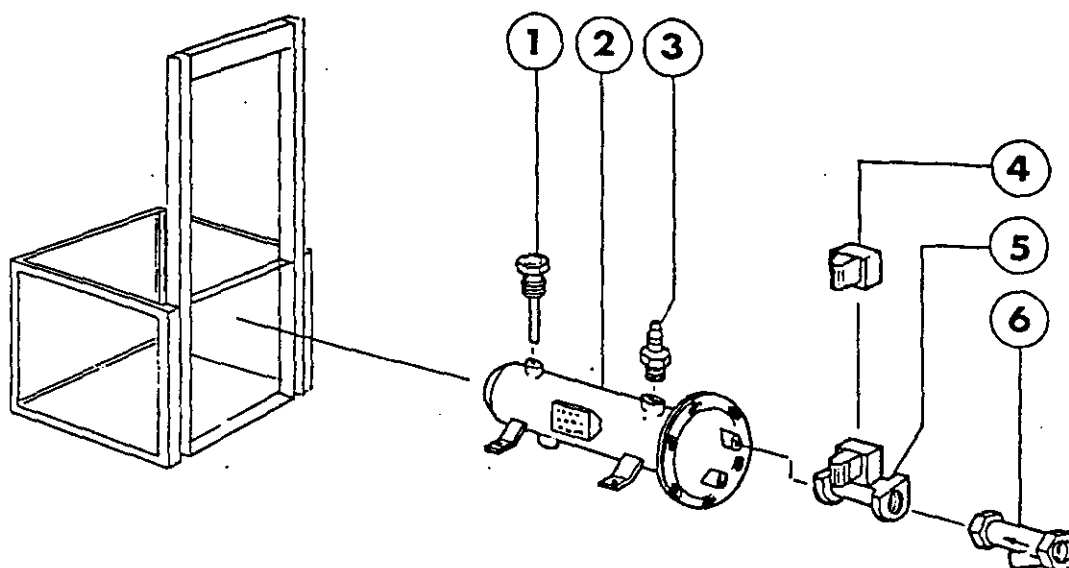

Pos.	Codice	Denominazione	Denomination	Description	Bezeichnung
1	450508	Guaina	Gaina	Shield	Hülle
2	330312	Boiler 6000Kca/h	Surchauffeur	Booster	Durchlauferhitzer
3	290410	Portagomma	Raccord	Hose barb	Anschluss
4	630949	Bobina	Bobine	Solenoid	Spule
5	120138	Elettrovalvola vapore	Electrovanne	Solenoid valve	E-Ventil Dampf
6	310601	Filtro Juker 1/2"	Filtre Juker 1/2"	Strainer Juker 1/2"	Filter Juker 1/2"