

RACK CONVEYOR MACHINE

ELECTROMECHANICAL SWITCHES
LOWER AND UPPER WASHER

TYPE: 39

Accessories

STEAM CONDENSER - LC 91
CONVEYOR SPEED ADJUSTING - LC 101
90°MOTORIZED CHAIN CONVEYOR - LC 97/2
180°MOTORIZED CHAIN CONVEYOR - LC 97/3
ADDITIONAL BOILER FOR COLD WATER SUPPLY
DVGW VALVE SYSTEM
DETERGENT ECONOMIZER SYSTEM
TANK INSULATION
DOUBLE SKIN
BOOSTER PUMP
DISPENSER SYSTEM SDN-3

Spare parts Manual



INFORMAZIONI GENERALI

Questo catalogo serve per richiedere con esattezza le parti di ricambio

Nelle ordinazioni indicare:

1) il numero dei codici dei particolari seguito dalla descrizione e la quantità desiderata;

2) Il codice alfa-numerico presente nella seconda colonna della tabella ;

I disegni delle parti di ricambio sono solo indicativi e non rappresentano il pezzo in oggetto.

I dati contenuti in questo catalogo sono indicativi e possono essere soggetti a modifiche senza impegno di preavviso.

ALLGEMEINE INFORMATIONEN

Dieser Ersatzteilkatalog dient zur genauen Angabe der Teile bei Ersatzteilbestellungen.

Bei Ersatzbestellung ist folgendes anzugeben:

1) Die Bestellnummer der Ersatzteile mit der entsprechenden Beschreibung genaue Menge;

2) Der alpha-numerischer Code auf der zweiten Reihe in dein Spalte;

Die Zeichnungen der Ersatzteile sind nur als Hinweise gedacht und stellen nicht das betroffene Teil dar.

Bei den im Katalog angeführten Daten handelt es sich um Anhaltsdaten, die jederzeit, ohne Vorankündigung, geändert werden können.

GENERAL INFORMATION

The present spare parts order exactly the right spare parts

When ordering specify:

1) the part's code number followed by its description and quantity needed;

2) The alpha-numeric code is in the second column in the chart;

Spare parts drawings are general and do not represent the part.

The contents of this catalogue are general and can undergo changes without prior notice.

INFORMACIONES GENERALES

El presente catálogo sirve para pedir con exactitud las partes de repuesto

En los pedidos se debe indicar:

1) el número de código de la parte y a continuación la descripción cantidad deseada;

2) El código alfanumerico presente en la signada columna de la tabla;

Los diseños de las partes de recambio son solo indicativos y no representan la pieza en cuestión.

Los datos contenidos en el presente catálogo son indicativos y pueden modificarse sin aviso previo.

INFORMATIONS GENERALES

Ce catalogue permet de commander correctement les pièces détachées

Les commandes doivent être passées en indiquant:

1) le numero de code des pièces détachées suivi de leur description quantité désirée;

2) le code alphanumérique dans la deuxième colonne du tableau;

Les plans des pièces détachées sont fournis seulement à titre indicatif et ne représentent pas la pièce concernée.

Les données de ce catalogue sont citées seulement à titre indicatif et peuvent être l'objet de modifications sans avis préalable.

ESEMPIO
EXAMPLE
EXEMPLE
BEISPIEL

Rif.	Codici
MODULE:Particolari	
10505	540903
10510	540908
10515	15065/A
10520	540086
10525	540028



Note

Tutte le informazioni riportate si intendono aggiornate alla data di stampa. Il Produttore si riserva il diritto di apportare qualsiasi modifica richiesta dallo sviluppo evolutivo dei suddetti prodotti.

Per la sicurezza, la garanzia, l'affidabilità ed il valore della lavastoviglie usa solo ricambi originali. **Per alcuni codici, sono richieste quantità minime d'ordine.**



Attenzione

Questo libretto è parte integrante della lavastoviglie e, in caso di passaggio di proprietà, deve essere consegnato al nuovo acquirente.



Remarque

Toutes les informations contenues dans ce manuel s'entendent mises à jour à la date d'impression. En raison du développement constant de ses produits, usine se réserve le droit d'apporter à tout instant les modifications qu'elle jugera utiles.

Pour la sécurité, la garantie, la fiabilité et la valeur de votre lave-vaisselles n'utilisez que des pièces de rechange d'origine. **Pour quelque référence on demande un minimum de pièces par commande**



Attention

Ce manuel doit être considéré comme partie intégrante de la lave-vaisselles, en cas de transfert de propriété, doit toujours être remis au nouveau propriétaire.



Note

The information contained herein is valid at the time of going to print. The Company reserves the right to make any changes required by the future development of the above-mentioned products.

For your safety, as well as to preserve the warranty reliability and worth of your dishwashers, use original spare parts only. **For some codes a minimum quantity for order is required.**



Warning

This manual forms an integral part of the dishwashers and - if a transfer of title occurs - must always be handed over to the new owner.



Hinweis

Die Der Hersteller behält sich das Recht vor, jegliche, durch eine Weiterentwicklung der genannten Produkte bedingte Änderungen vornehmen zu können.

Verwenden Sie für Ihre Sicherheit, die Garantie, die Zuverlässigkeit und den Wert Ihrer machine originale Ersatzteile. **Für bestimmte Code nummer werden mindesten bestellungen verlangt.**



Achtung

Diese Betriebsanleitung ist Bestandteil des machine und muss bei seinem Weiterverkauf dem neuen Besitzer ausgehändigt werden.





Code DW 999XXXXXX **CL/Part**

Model DESCRIPTION

S/N DW A 1015770 **Type**

400V 3N 50HZ 8A
3500W 500W

  16A

Pressione Dinamica alimentazione idrica **200-500 kPa**

Pression dynamique arrivèe d'eau

Dynamic pressure water supply

Dynamischer Druck asserreinlauf

Pressione dinamica vapore saturo

Pression dynamique vapore satueèe

Dymanischer Druck gesattigter Dampf

Pression Dinamica Vapor Saturado

TECHICAL SPECIFICATION



MADE IN ITALY

Temperatura massima acqua in ingresso **60°C**

Temperature max eau a l'entre

Maximale Temperatur Wasseranschlu

Maximum Water temperature in-feeding



Model 

S/N 

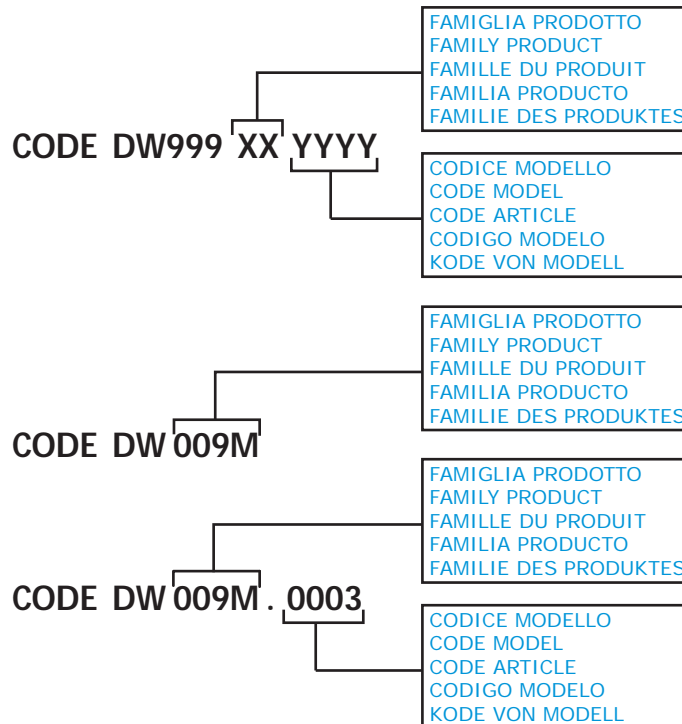

1. Spare parts

Control Panel.....	9
Electric parts.....	11
General parts	13
Economizer components	15
Curtains group components	17
Inverter.....	19
Time relay	21
Steam condenser LC91 - part 1.....	23
Steam condenser LC91 - part 2.....	25
Steam condenser - part 3	27
Additional boiler components	29
Additional boiler: electrical components...31	
DVGW valve	33
Motorgear components module 1300 .35	
Washing components	37
Washing components	39

Internal components washing module 1300...41	
Rinsing components 45	
Boiler components 47	
Solenoid valves components: tank loading + rinsing...49	
Solenoid valves components: tank loading + rinsing + steam condenser 51	
Conveyor parts 53	
Tank insulation 55	
Double skin..... 57	
Booster pump..... 59	
Dispensers SDN-3 61	
Accessory..... 63	

1.1 Voltage codes

Volt	Voltage code
A	3/N/PE~380-400V 50-60Hz
D	3/PE~200-210V 50-60Hz
F	2/PE~220-240V 50-60Hz
G	3/N/PE~415V 50-60Hz
H	3/PE~220-230V 50-60Hz
K	3/PE~380-400V 50-60Hz
L	3/PE~415V 50-60Hz
M	3/PE~440V 60Hz
P	1/N/PE~220-230V 50-60Hz
R	2/PE~220-240V 50-60Hz
U	1/N/PE~240V 50-60Hz
V	3/PE~240V 50-60Hz
W	1/N/PE~100-110V 50-60Hz

1.2 Product codes

Product code	Full name
Model codes	
em	ELECTROMECHANICAL SWITCHES
e	ELECTRONICAL SWITCHES
uw	LOWER AND UPPER WASHER
Type codes	
39	39
Accessory codes	
sc9	STEAM CONDENSER - LC 91
csa	CONVEYOR SPEED ADJUSTING - LC 101
972	90°MOTORIZED CHAIN CONVEYOR - LC 97/2
973	180°MOTORIZED CHAIN CONVEYOR - LC 97/3
cw	ADDITIONAL BOILER FOR COLD WATER SUPPLY
dvgw	DVGW VALVE SYSTEM
des	DETERGENT ECONOMIZER SYSTEM
ti	TANK INSULATION
ds	DOUBLE SKIN
bp	BOOSTER PUMP
sdn3	DISPENSER SYSTEM SDN-3

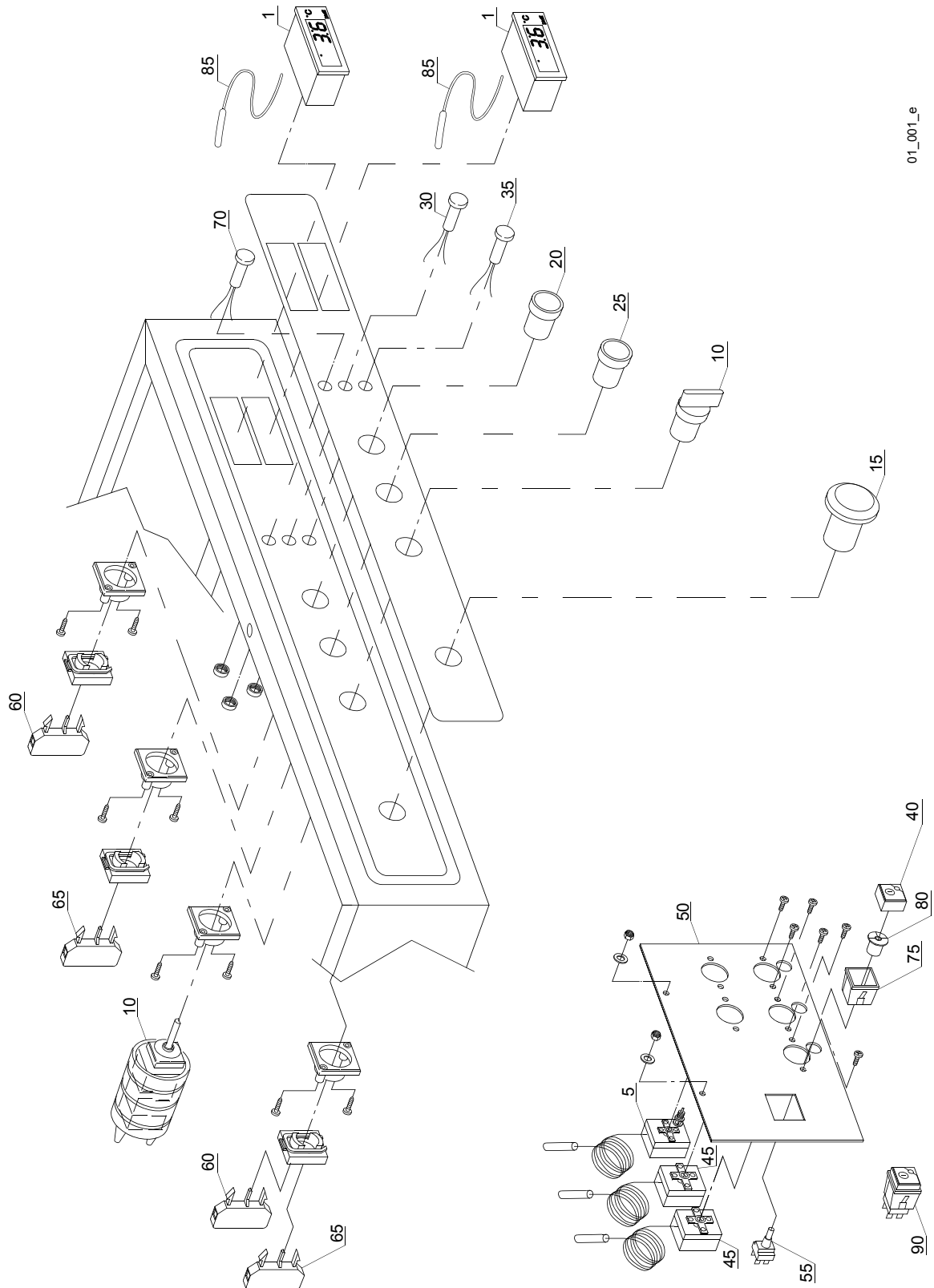

01_001_e

Spare parts

ID	P-code	SN from	SN to	Mod.	Acces.	Volt	Description
Module:Control Panel							
1	2000402		-	em,uw			Thermometer
5	2000430		-	em,uw			Safety thermostat
10	3002031		-	em,uw			Selector with knob
15	3002050		-	em,uw			Emergency button
20	3002053		-	em,uw			Push button green
25	3002055		-	em,uw			Button red
30	3002065		-	em,uw			Signal light red
35	3002067		-	em,uw			Signal light yellow
40	15874		-	em,uw			Green main switch
45	10707/1		-	em,uw			Thermostat 0 - 90° (TB2)
50	3009114		-	em,uw			Assembly plate
55	15812		-	em,uw			Starter electric component
60	3002054		-	em,uw			Green contact piece (NO)
65	3002056		-	em,uw			Red contact piece (NC)
70	3002066		-	em,uw			Signal light green
75	15815		-	em,uw			Support square single
80	15824		-	em,uw			Green-orange cam
85	2000401		-	em,uw			Thermometer probe
90	15849		-	em,uw			Switch assembly (PM2)

em=ELECTROMECHANICAL SWITCHES, uw=LOWER AND UPPER WASHER

39=39

sc9=STEAM CONDENSER - LC 91, csa=CONVEYOR SPEED ADJUSTING - LC 101, 972=90°MOTORIZED CHAIN CONVEYOR - LC 97/2, 973=180°MOTORIZED CHAIN CONVEYOR - LC 97/3, cw=ADDITIONAL BOILER FOR COLD WATER SUPPLY, dvgw=DVGW VALVE SYSTEM, des=DETERGENT ECONOMIZER SYSTEM, ti=TANK INSULATION, ds=DOUBLE SKIN, bp=BOOSTER PUMP, sdn3=DISPENSER SYSTEM SDN-3

A=3/N/PE~380-400V 50-60Hz, D=3/PE~200-210V 50-60Hz, F=2/PE~220-240V 50-60Hz, G=3/N/PE~415V 50-60Hz, H=3/PE~220-230V 50-60Hz, K=3/PE~380-400V 50-60Hz, L=3/PE~415V 50-60Hz, M=3/PE~440V 60Hz, P=1/N/PE~220-230V 50-60Hz, R=2/PE~220-240V 50-60Hz, U=1/N/PE~240V 50-60Hz, V=3/PE~240V 50-60Hz, W=1/N/PE~100-110V 50-60Hz

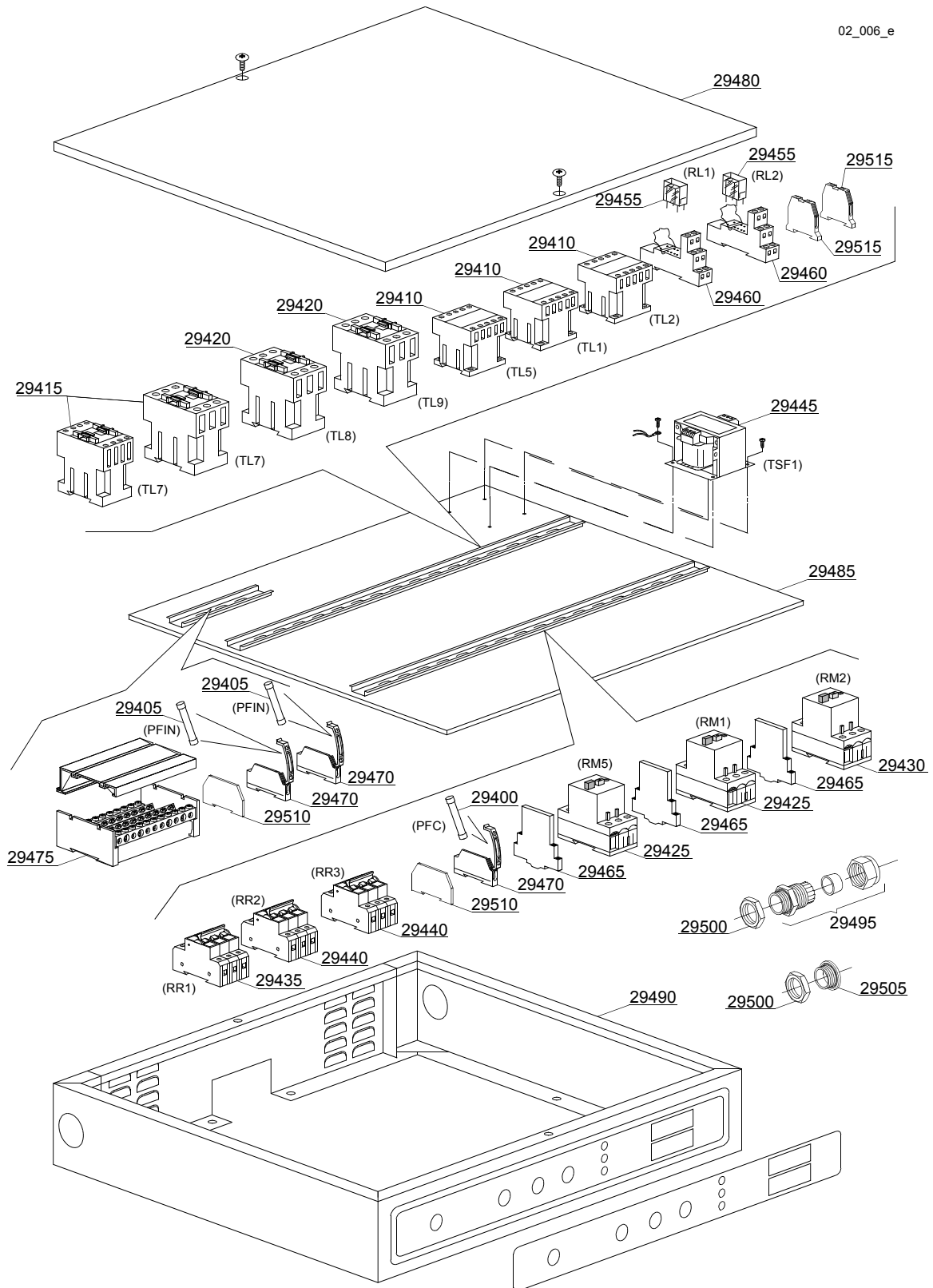

Spare parts

ID	P-code	SN from	SN to	Mod.	Acces.	Volt	Description
Module:Electric parts							
29400	15160		-	em,uw		A	Fuse 5x20 10A
29405	15163		-	em,uw		A	Fuse 5x20 1A
29410	2000370		-	em,uw		A	Contactora MC9
29415	2000380		-	em,uw		A	Contactora BF12 (heating element < 9 kW)
29415	2000385		-	em,uw		A	Contactora BF20 (heating element > 9 kW)
29420	2000385		-	em,uw		A	Contactora BF20
29425	2000390		-	em,uw		A	Motorprotector 1 - 1.6A
29430	2000400		-	em,uw		A	Motorprotector 4 - 6.3A
29435	2000403		-	em,uw		A	Automatic fuse C20 (heating element < 9kW)
29435	2000404		-	em,uw		A	Automatic fuse C25 (heating element > 9kW)
29440	2000403		-	em,uw		A	Automatic fuse C20 (heating element < 9kW)
29440	2000404		-	em,uw		A	Automatic fuse C25 (heating element > 9kW)
29445	3006061		-	em,uw		A	Transformer 200VA
29445	3006060		-	em,uw		A	Transformer 160VA
29455	3006078		-	em,uw		A	Relay
29460	3006079		-	em,uw		A	Base for relay
29465	3006080		-	em,uw		A	Auxiliary contact LMS25
29470	3006147		-	em,uw		A	Fuse holder
29475	3006154		-	em,uw		A	Terminal board
29480	3009457		-	em,uw		A	Control panel cover
29485	3009458		-	em,uw		A	Electric parts pannel
29490	3019033		-	em,uw		A	Comand parts pannel
29495	80419		-	em,uw		A	Cable-fastener PG29
29500	80420		-	em,uw		A	Lock nut
29505	80421		-	em,uw		A	Plug PG29
29510	3006144		-	em,uw		A	Fuse holder covering plate
29515	3006092		-	em,uw		A	Clamp 4mm ²

em=ELECTROMECHANICAL SWITCHES, uw=LOWER AND UPPER WASHER

39=39

sc9=STEAM CONDENSER - LC 91, csa=CONVEYOR SPEED ADJUSTING - LC 101, 972=90°MOTORIZED CHAIN CONVEYOR - LC 97/2, 973=180°MOTORIZED CHAIN CONVEYOR - LC 97/3, cw=ADDITIONAL BOILER FOR COLD WATER SUPPLY, dvgw=DVGW VALVE SYSTEM, des=DETERGENT ECONOMIZER SYSTEM, ti=TANK INSULATION, ds=DOUBLE SKIN, bp=BOOSTER PUMP, sdn3=DISPENSER SYSTEM SDN-3

A=3/N/PE~380-400V 50-60Hz, D=3/PE~200-210V 50-60Hz, F=2/PE~220-240V 50-60Hz, G=3/N/PE~415V 50-60Hz, H=3/PE~220-230V 50-60Hz, K=3/PE~380-400V 50-60Hz, L=3/PE~415V 50-60Hz, M=3/PE~440V 60Hz, P=1/N/PE~220-230V 50-60Hz, R=2/PE~220-240V 50-60Hz, U=1/N/PE~240V 50-60Hz, V=3/PE~240V 50-60Hz, W=1/N/PE~100-110V 50-60Hz

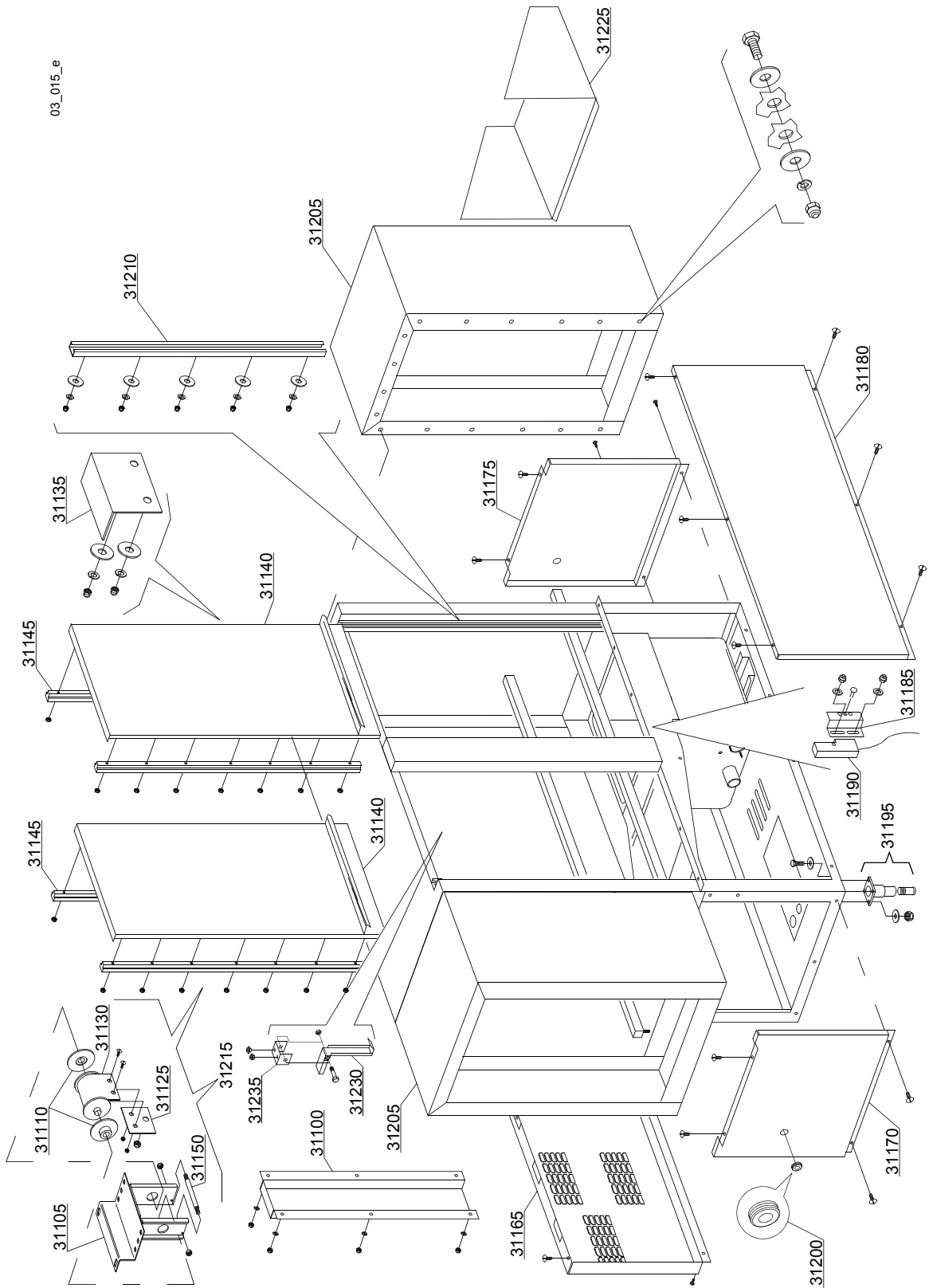

Spare parts

ID	P-code	SN from	SN to	Mod.	Acces.	Volt	Description
Module:General parts							
31100	3009606		-	em,uw			Rear cover
31105	3009909		-	em,uw			Spring support
31110	3004012		-	em,uw			Spring holder
31125	3009555		-	em,uw			Spring clamping plate
31130	3004011		-	em,uw			Door spring BBSR 23
31135	3009269		-	em,uw			Door stop
31140	3009599		-	em,uw			Door assembly
31145	3004118		-	em,uw			Door guide
31150	3003958		-	em,uw			Pin
31165	3009173		-	em,uw			Rear panel
31170	3009189		-	em,uw			Cover left
31175	3009188		-	em,uw			Cover right
31180	3009465		-	em,uw			Front cover
31185	3009112		-	em,uw			Microswitch support
31190	3003112		-	em,uw			Door microswitch
31195	80116		-	em,uw			Foot
31200	13329		-	em,uw			Fairlead
31205	3009604		-	em,uw			Splash zone
31210	3009595		-	em,uw			Slideways
31215	3009905		-	em,uw			Spring assembly BBSR 23
31225	3009365		-	em,uw			Chute
31230	3000323		-	em,uw			Hook door
31235	3000324		-	em,uw			Hook support

em=ELECTROMECHANICAL SWITCHES, uw=LOWER AND UPPER WASHER

39=39

sc9=STEAM CONDENSER - LC 91, csa=CONVEYOR SPEED ADJUSTING - LC 101, 972=90°MOTORIZED CHAIN CONVEYOR - LC 97/2, 973=180°MOTORIZED CHAIN CONVEYOR - LC 97/3, cw=ADDITIONAL BOILER FOR COLD WATER SUPPLY, dvgw=DVGW VALVE SYSTEM, des=DETERGENT ECONOMIZER SYSTEM, ti=TANK INSULATION, ds=DOUBLE SKIN, bp=BOOSTER PUMP, sdn3=DISPENSER SYSTEM SDN-3

A=3/N/PE~380-400V 50-60Hz, D=3/PE~200-210V 50-60Hz, F=2/PE~220-240V 50-60Hz, G=3/N/PE~415V 50-60Hz, H=3/PE~220-230V 50-60Hz, K=3/PE~380-400V 50-60Hz, L=3/PE~415V 50-60Hz, M=3/PE~440V 60Hz, P=1/N/PE~220-230V 50-60Hz, R=2/PE~220-240V 50-60Hz, U=1/N/PE~240V 50-60Hz, V=3/PE~240V 50-60Hz, W=1/N/PE~100-110V 50-60Hz

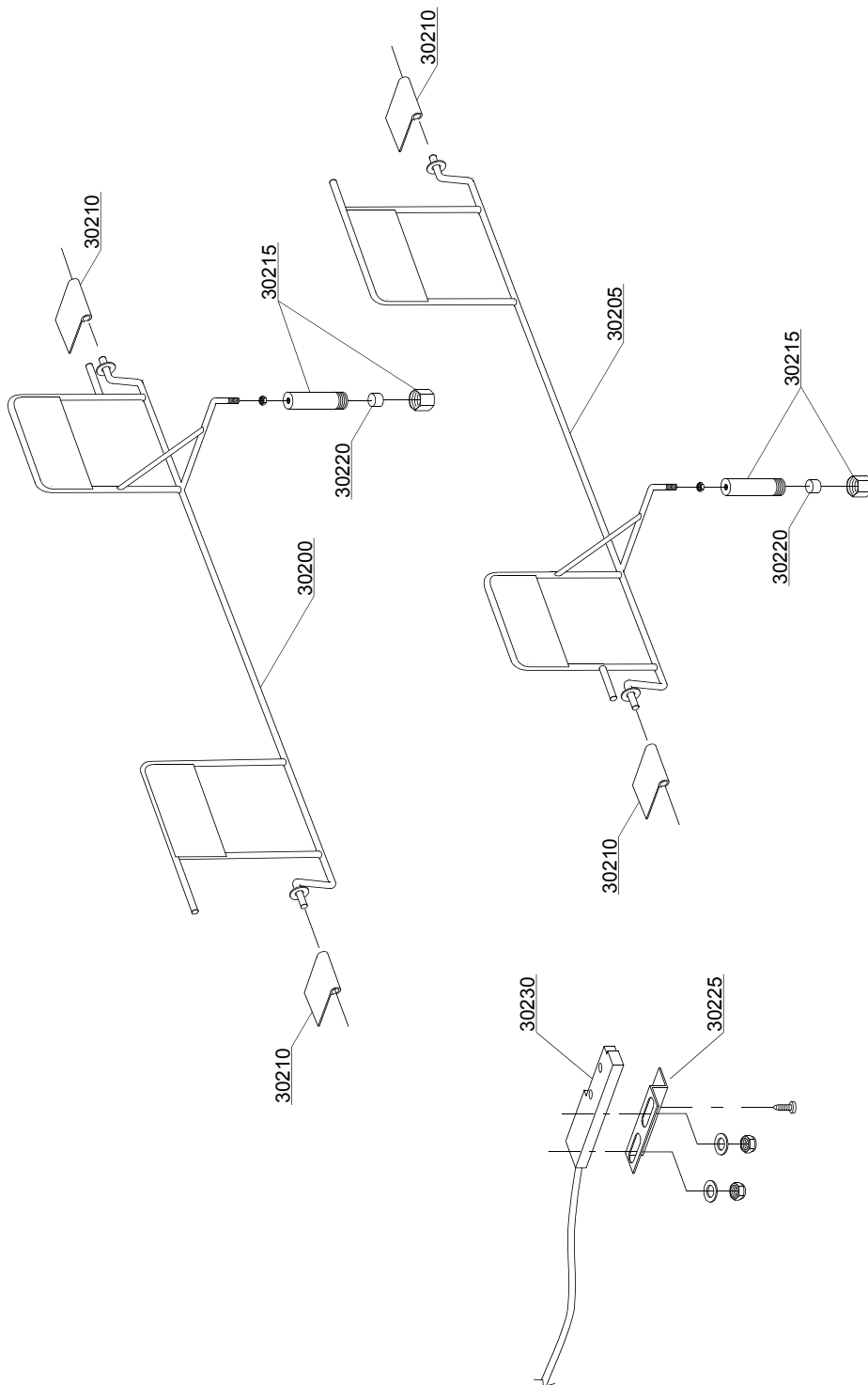

03_103_e

Spare parts

ID	P-code	SN from	SN to	Mod.	Acces.	Volt	Description
Module:Economizer components							
30200	3004124		-	em,uw			Right economizer
30205	3004125		-	em,uw			Left economizer
30210	3003061		-	em,uw			Economizer support
30215	3003058		-	em,uw			Magnet holder
30220	3003113		-	em,uw			Magnet
30225	3009112		-	em,uw			Door microswitch support
30230	3003112		-	em,uw			Door microswitch

em=ELECTROMECHANICAL SWITCHES, uw=LOWER AND UPPER WASHER

39=39

sc9=STEAM CONDENSER - LC 91, csa=CONVEYOR SPEED ADJUSTING - LC 101, 972=90°MOTORIZED CHAIN CONVEYOR - LC 97/2, 973=180°MOTORIZED CHAIN CONVEYOR - LC 97/3, cw=ADDITIONAL BOILER FOR COLD WATER SUPPLY, dvgw=DVGW VALVE SYSTEM, des=DETERGENT ECONOMIZER SYSTEM, ti=TANK INSULATION, ds=DOUBLE SKIN, bp=BOOSTER PUMP, sdn3=DISPENSER SYSTEM SDN-3

A=3/N/PE~380-400V 50-60Hz, D=3/PE~200-210V 50-60Hz, F=2/PE~220-240V 50-60Hz, G=3/N/PE~415V 50-60Hz, H=3/PE~220-230V 50-60Hz, K=3/PE~380-400V 50-60Hz, L=3/PE~415V 50-60Hz, M=3/PE~440V 60Hz, P=1/N/PE~220-230V 50-60Hz, R=2/PE~220-240V 50-60Hz, U=1/N/PE~240V 50-60Hz, V=3/PE~240V 50-60Hz, W=1/N/PE~100-110V 50-60Hz

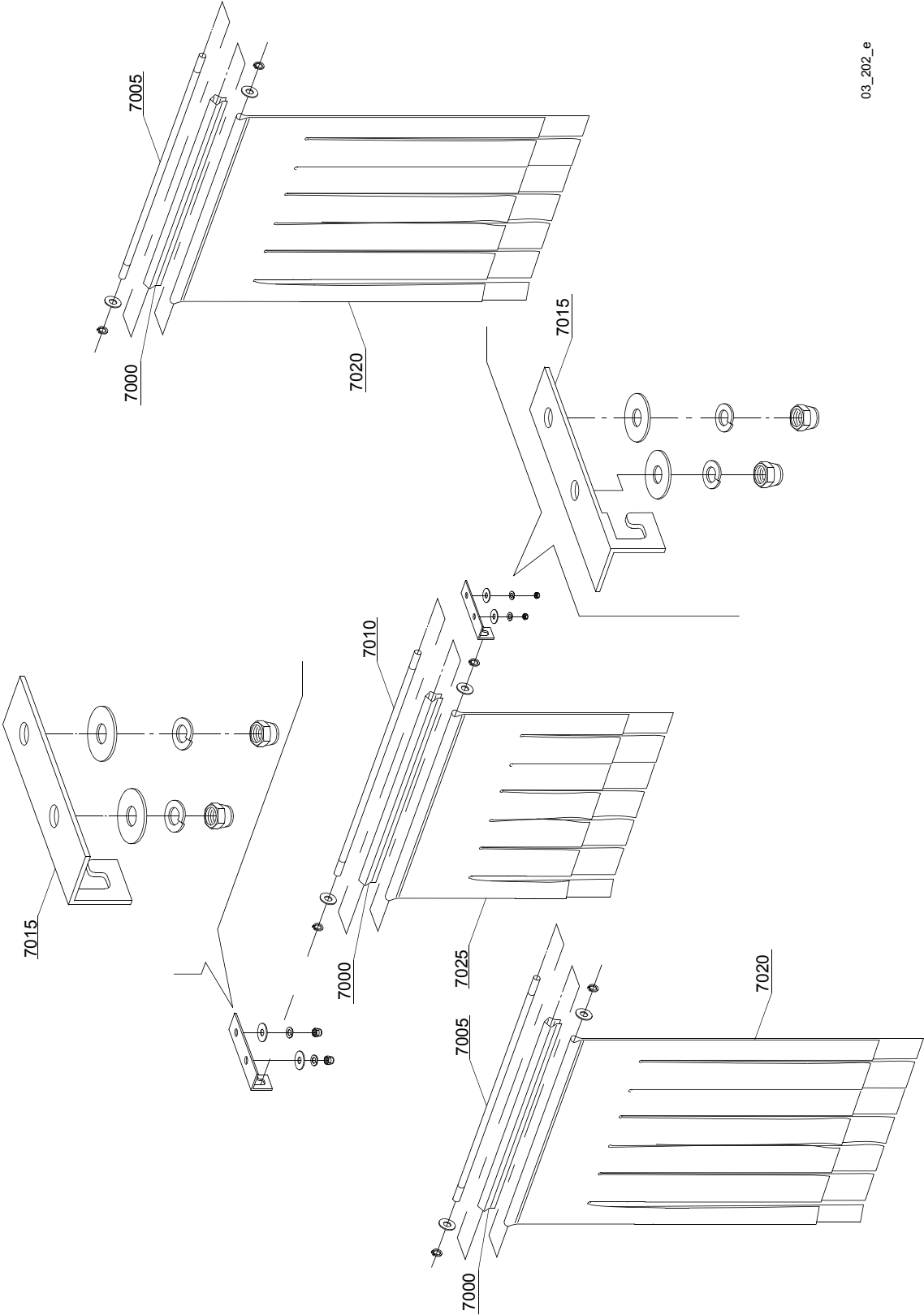

03_202_e

Spare parts

ID	P-code	SN from	SN to	Mod.	Acces.	Volt	Description
Module: Curtains group components							
7000	3009109		-	em,uw			Curtain moulding
7005	3004053		-	em,uw			Curtain rod long
7010	3004052		-	em,uw			Curtain rod short
7015	3009110		-	em,uw			Curtain support
7020	3004117		-	em,uw			Curtain long
7025	3004051		-	em,uw			Curtain short

em=ELECTROMECHANICAL SWITCHES, uw=LOWER AND UPPER WASHER

39=39

sc9=STEAM CONDENSER - LC 91, csa=CONVEYOR SPEED ADJUSTING - LC 101, 972=90°MOTORIZED CHAIN CONVEYOR - LC 97/2, 973=180°MOTORIZED CHAIN CONVEYOR - LC 97/3, cw=ADDITIONAL BOILER FOR COLD WATER SUPPLY, dvgw=DVGW VALVE SYSTEM, des=DETERGENT ECONOMIZER SYSTEM, ti=TANK INSULATION, ds=DOUBLE SKIN, bp=BOOSTER PUMP, sdn3=DISPENSER SYSTEM SDN-3

A=3/N/PE~380-400V 50-60Hz, D=3/PE~200-210V 50-60Hz, F=2/PE~220-240V 50-60Hz, G=3/N/PE~415V 50-60Hz, H=3/PE~220-230V 50-60Hz, K=3/PE~380-400V 50-60Hz, L=3/PE~415V 50-60Hz, M=3/PE~440V 60Hz, P=1/N/PE~220-230V 50-60Hz, R=2/PE~220-240V 50-60Hz, U=1/N/PE~240V 50-60Hz, V=3/PE~240V 50-60Hz, W=1/N/PE~100-110V 50-60Hz

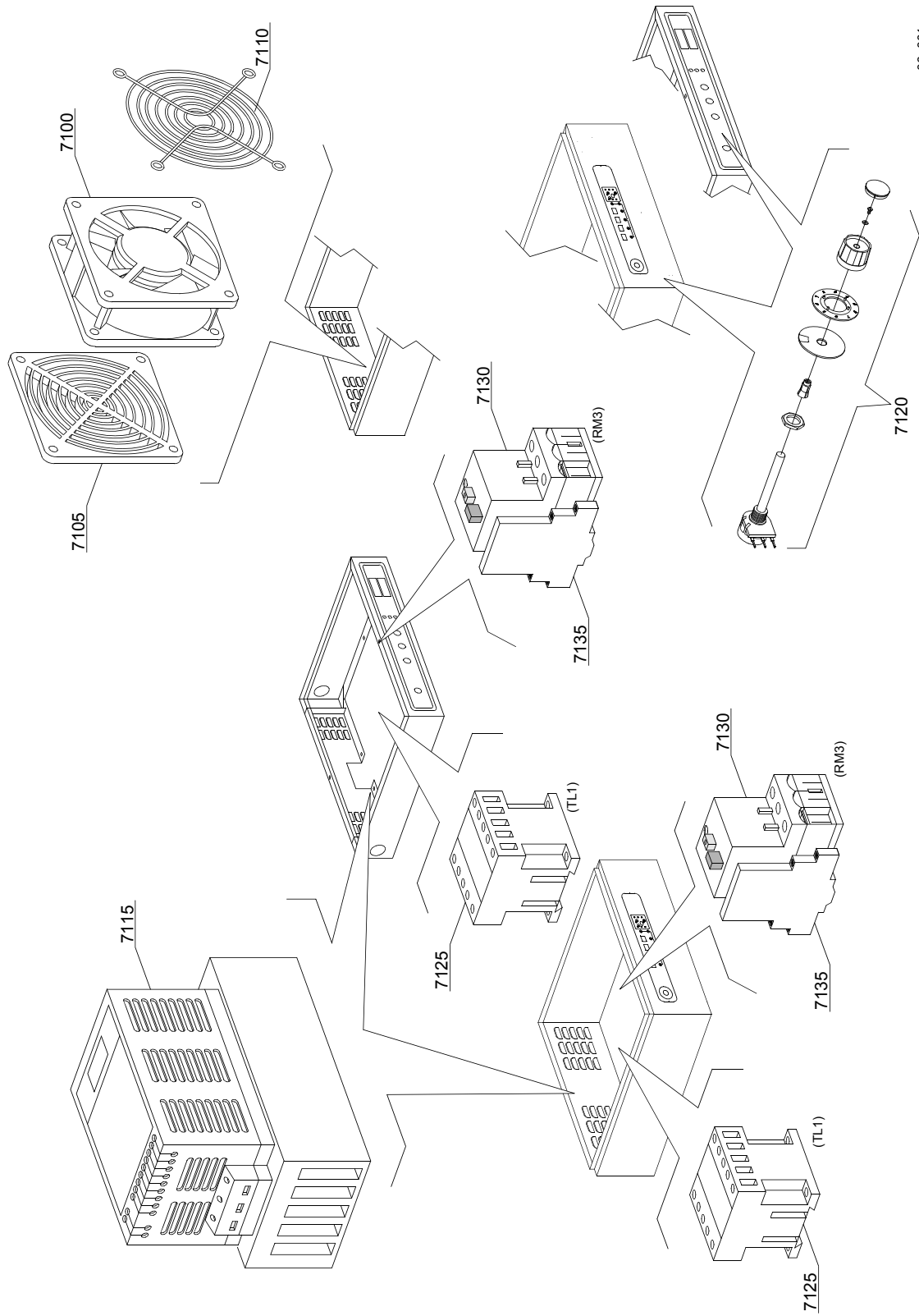

06_001_e

Spare parts

ID	P-code	SN from	SN to	Mod.	Acces.	Volt	Description
Module: Inverter							
7100	3000118		-	em,uw		A	Impeller fan
7105	3000118/A		-	em,uw		A	Filter
7110	3000118/B		-	em,uw		A	Grid
7115	3000117		-	em,uw		A	Inverter 0,37kW
7120	3000119		-	em,uw		A	Potentiometer with knob
7125	2000370		-	em,uw		A	Contactora MC9
7130	2000400		-	em,uw		A	Motorprotector 4-6,3A
7135	3006080		-	em,uw		A	Auxiliary contact LMS25

em=ELECTROMECHANICAL SWITCHES, uw=LOWER AND UPPER WASHER

39=39

sc9=STEAM CONDENSER - LC 91, csa=CONVEYOR SPEED ADJUSTING - LC 101, 972=90°MOTORIZED CHAIN CONVEYOR - LC 97/2, 973=180°MOTORIZED CHAIN CONVEYOR - LC 97/3, cw=ADDITIONAL BOILER FOR COLD WATER SUPPLY, dvgw=DVGW VALVE SYSTEM, des=DETERGENT ECONOMIZER SYSTEM, ti=TANK INSULATION, ds=DOUBLE SKIN, bp=BOOSTER PUMP, sdn3=DISPENSER SYSTEM SDN-3

A=3/N/PE~380-400V 50-60Hz, D=3/PE~200-210V 50-60Hz, F=2/PE~220-240V 50-60Hz, G=3/N/PE~415V 50-60Hz, H=3/PE~220-230V 50-60Hz, K=3/PE~380-400V 50-60Hz, L=3/PE~415V 50-60Hz, M=3/PE~440V 60Hz, P=1/N/PE~220-230V 50-60Hz, R=2/PE~220-240V 50-60Hz, U=1/N/PE~240V 50-60Hz, V=3/PE~240V 50-60Hz, W=1/N/PE~100-110V 50-60Hz

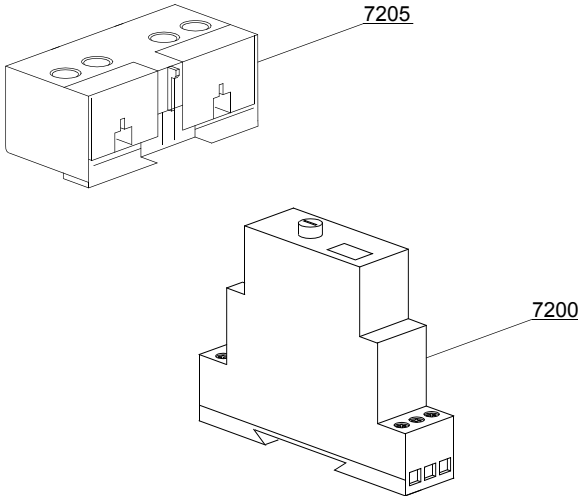

07_001_e

Spare parts

ID	P-code	SN from	SN to	Mod.	Acces.	Volt	Description
Module:Time relay							
7200	3006226		-	em,uw		A	Time relay 24V
7200	3006226		-	em,uw		A	Time relay 24V
7205	3006068		-	em,uw		A	MC9 auxiliary contact 1NO-1NC
7205	3002057		-	em,uw		A	MC9 auxiliary contact 2NO
7205	3002052		-	em,uw		A	MC9 auxiliary contact 2NC

em=ELECTROMECHANICAL SWITCHES, uw=LOWER AND UPPER WASHER

39=39

sc9=STEAM CONDENSER - LC 91, csa=CONVEYOR SPEED ADJUSTING - LC 101, 972=90°MOTORIZED CHAIN CONVEYOR - LC 97/2, 973=180°MOTORIZED CHAIN CONVEYOR - LC 97/3, cw=ADDITIONAL BOILER FOR COLD WATER SUPPLY, dvgw=DVGW VALVE SYSTEM, des=DETERGENT ECONOMIZER SYSTEM, ti=TANK INSULATION, ds=DOUBLE SKIN, bp=BOOSTER PUMP, sdn3=DISPENSER SYSTEM SDN-3

A=3/N/PE~380-400V 50-60Hz, D=3/PE~200-210V 50-60Hz, F=2/PE~220-240V 50-60Hz, G=3/N/PE~415V 50-60Hz, H=3/PE~220-230V 50-60Hz, K=3/PE~380-400V 50-60Hz, L=3/PE~415V 50-60Hz, M=3/PE~440V 60Hz, P=1/N/PE~220-230V 50-60Hz, R=2/PE~220-240V 50-60Hz, U=1/N/PE~240V 50-60Hz, V=3/PE~240V 50-60Hz, W=1/N/PE~100-110V 50-60Hz

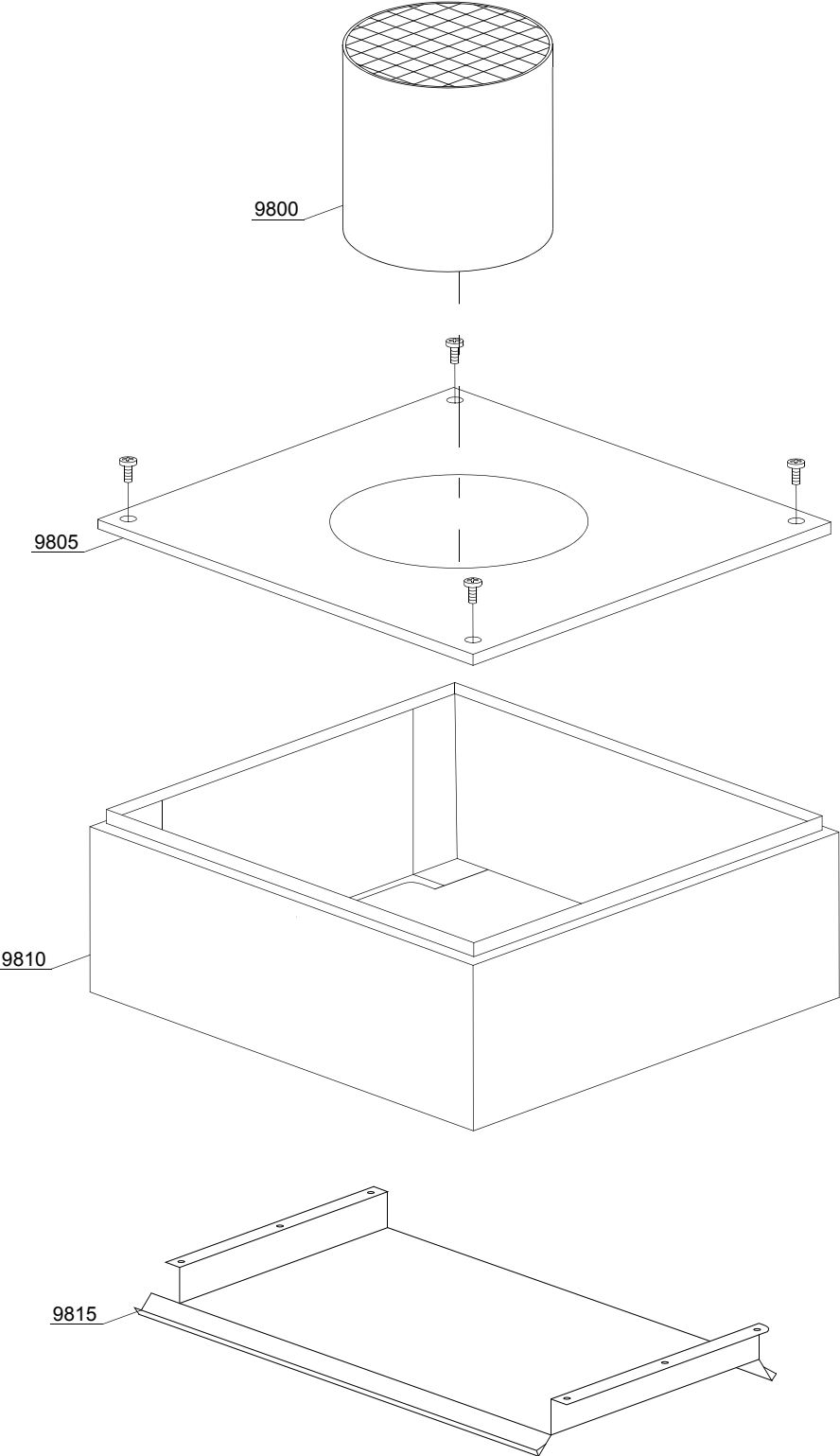

18_001_e

Spare parts

ID	P-code	SN from	SN to	Mod.	Acces.	Volt	Description
Module:Steam condenser LC91 - part 1							
9800	3009499		-	em,uw			Chimney
9805	3009306		-	em,uw			Cover with hole
9810	3009502		-	em,uw			Complete body
9815	3009090		-	em,uw			Suction group

em=ELECTROMECHANICAL SWITCHES, uw=LOWER AND UPPER WASHER

39=39

sc9=STEAM CONDENSER - LC 91, csa=CONVEYOR SPEED ADJUSTING - LC 101, 972=90°MOTORIZED CHAIN CONVEYOR - LC 97/2, 973=180°MOTORIZED CHAIN CONVEYOR - LC 97/3, cw=ADDITIONAL BOILER FOR COLD WATER SUPPLY, dvgw=DVGW VALVE SYSTEM, des=DETERGENT ECONOMIZER SYSTEM, ti=TANK INSULATION, ds=DOUBLE SKIN, bp=BOOSTER PUMP, sdn3=DISPENSER SYSTEM SDN-3

A=3/N/PE~380-400V 50-60Hz, D=3/PE~200-210V 50-60Hz, F=2/PE~220-240V 50-60Hz, G=3/N/PE~415V 50-60Hz, H=3/PE~220-230V 50-60Hz, K=3/PE~380-400V 50-60Hz, L=3/PE~415V 50-60Hz, M=3/PE~440V 60Hz, P=1/N/PE~220-230V 50-60Hz, R=2/PE~220-240V 50-60Hz, U=1/N/PE~240V 50-60Hz, V=3/PE~240V 50-60Hz, W=1/N/PE~100-110V 50-60Hz

18_101_e

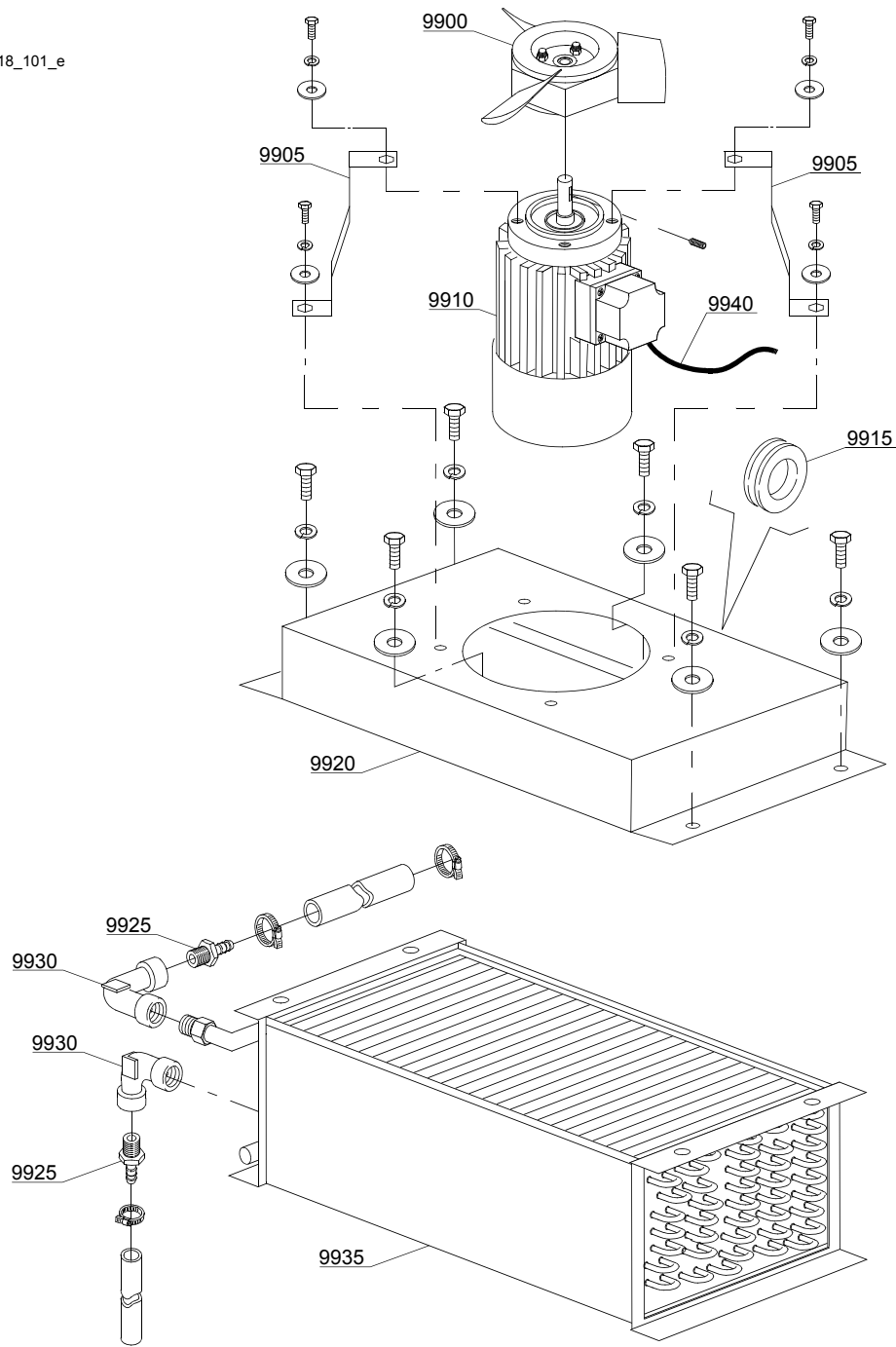

Spare parts

ID	P-code	SN from	SN to	Mod.	Acces.	Volt	Description
Module:Steam condenser LC91 - part 2							
9900	3000125		-	em,uw			Impeller fan
9905	3009106		-	em,uw			Motor holder
9910	3000120		-	em,uw		A	Motor - 0,18KW 4P 230/400V 50HZ
9915	13329		-	em,uw			Fairlead
9920	3009079		-	em,uw			Steam condenser base
9925	12023		-	em,uw			Hose holder
9930	3002139		-	em,uw			Elbow
9935	3000155		-	em,uw			Heating recovery battery
9940	15184		-	em,uw			Cable

em=ELECTROMECHANICAL SWITCHES, uw=LOWER AND UPPER WASHER

39=39

sc9=STEAM CONDENSER - LC 91, csa=CONVEYOR SPEED ADJUSTING - LC 101, 972=90°MOTORIZED CHAIN CONVEYOR - LC 97/2, 973=180°MOTORIZED CHAIN CONVEYOR - LC 97/3, cw=ADDITIONAL BOILER FOR COLD WATER SUPPLY, dvgw=DVGW VALVE SYSTEM, des=DETERGENT ECONOMIZER SYSTEM, ti=TANK INSULATION, ds=DOUBLE SKIN, bp=BOOSTER PUMP, sdn3=DISPENSER SYSTEM SDN-3

A=3/N/PE~380-400V 50-60Hz, D=3/PE~200-210V 50-60Hz, F=2/PE~220-240V 50-60Hz, G=3/N/PE~415V 50-60Hz, H=3/PE~220-230V 50-60Hz, K=3/PE~380-400V 50-60Hz, L=3/PE~415V 50-60Hz, M=3/PE~440V 60Hz, P=1/N/PE~220-230V 50-60Hz, R=2/PE~220-240V 50-60Hz, U=1/N/PE~240V 50-60Hz, V=3/PE~240V 50-60Hz, W=1/N/PE~100-110V 50-60Hz

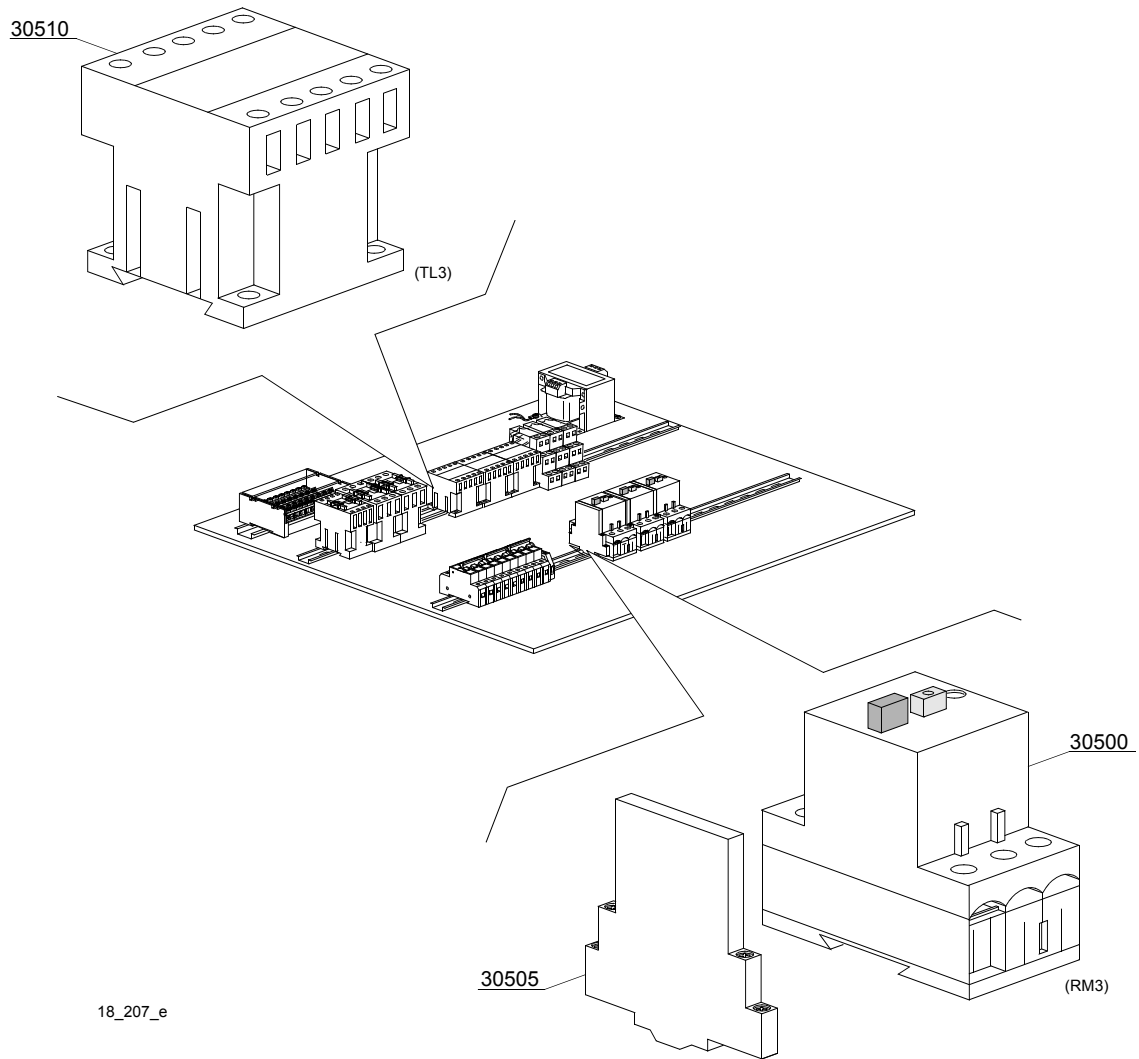

18_207_e

Spare parts

ID	P-code	SN from	SN to	Mod.	Acces.	Volt	Description
Module:Steam condenser - part 3							
30500	2000390		-	em,uw		A	Motorprotector 1 - 1.6A
30505	3006080		-	em,uw		A	Auxiliary contact LMS25
30510	2000370		-	em,uw		A	Contactore MC9

em=ELECTROMECHANICAL SWITCHES, uw=LOWER AND UPPER WASHER

39=39

sc9=STEAM CONDENSER - LC 91, csa=CONVEYOR SPEED ADJUSTING - LC 101, 972=90°MOTORIZED CHAIN CONVEYOR - LC 97/2, 973=180°MOTORIZED CHAIN CONVEYOR - LC 97/3, cw=ADDITIONAL BOILER FOR COLD WATER SUPPLY, dvgw=DVGW VALVE SYSTEM, des=DETERGENT ECONOMIZER SYSTEM, ti=TANK INSULATION, ds=DOUBLE SKIN, bp=BOOSTER PUMP, sdn3=DISPENSER SYSTEM SDN-3

A=3/N/PE~380-400V 50-60Hz, D=3/PE~200-210V 50-60Hz, F=2/PE~220-240V 50-60Hz, G=3/N/PE~415V 50-60Hz, H=3/PE~220-230V 50-60Hz, K=3/PE~380-400V 50-60Hz, L=3/PE~415V 50-60Hz, M=3/PE~440V 60Hz, P=1/N/PE~220-230V 50-60Hz, R=2/PE~220-240V 50-60Hz, U=1/N/PE~240V 50-60Hz, V=3/PE~240V 50-60Hz, W=1/N/PE~100-110V 50-60Hz

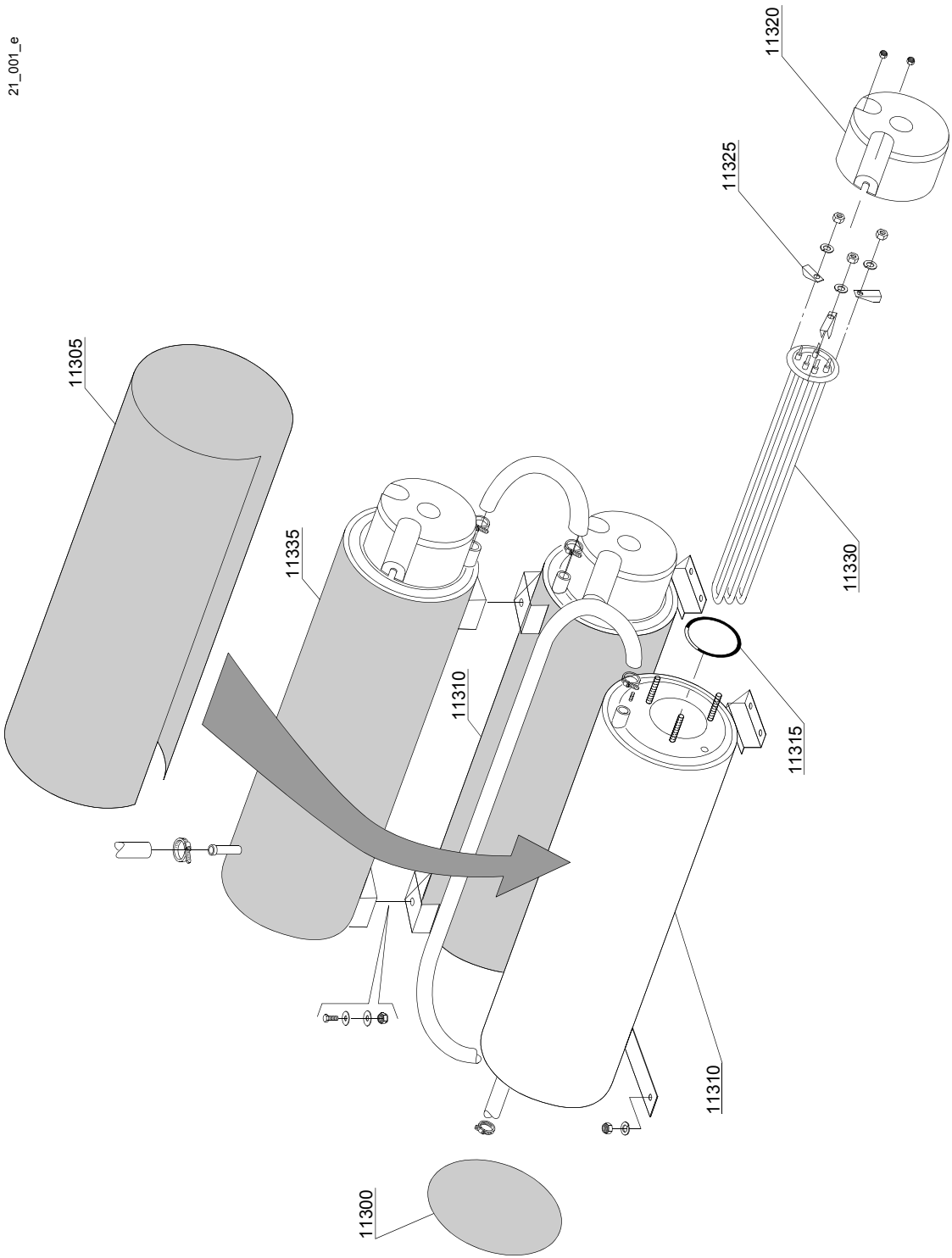

Spare parts

ID	P-code	SN from	SN to	Mod.	Acces.	Volt	Description
Module:Additional boiler components							
11300	75205		-	em,uw			Bottom boiler insulating
11305	30002030		-	em,uw			Boiler insulating
11310	3007012		-	em,uw			Inferiour Boiler
11315	13015		-	em,uw			O-ring 160 (6225)
11320	75311		-	em,uw			Heating element cover
11325	16045		-	em,uw			Heating element support Ø6,3
11330	30001010		-	em,uw		A	Heating element 6kW
11330	30001011		-	em,uw		A	Heating element 9kW
11330	30001011/A		-	em,uw		A	Heating element 12kW
11330	30001011/B		-	em,uw		A	Heating element 14kW
11335	3007013		-	em,uw			Upper Boiler

em=ELECTROMECHANICAL SWITCHES, uw=LOWER AND UPPER WASHER

39=39

sc9=STEAM CONDENSER - LC 91, csa=CONVEYOR SPEED ADJUSTING - LC 101, 972=90°MOTORIZED CHAIN CONVEYOR - LC 97/2, 973=180°MOTORIZED CHAIN CONVEYOR - LC 97/3, cw=ADDITIONAL BOILER FOR COLD WATER SUPPLY, dvgw=DVGW VALVE SYSTEM, des=DETERGENT ECONOMIZER SYSTEM, ti=TANK INSULATION, ds=DOUBLE SKIN, bp=BOOSTER PUMP, sdn3=DISPENSER SYSTEM SDN-3

A=3/N/PE~380-400V 50-60Hz, D=3/PE~200-210V 50-60Hz, F=2/PE~220-240V 50-60Hz, G=3/N/PE~415V 50-60Hz, H=3/PE~220-230V 50-60Hz, K=3/PE~380-400V 50-60Hz, L=3/PE~415V 50-60Hz, M=3/PE~440V 60Hz, P=1/N/PE~220-230V 50-60Hz, R=2/PE~220-240V 50-60Hz, U=1/N/PE~240V 50-60Hz, V=3/PE~240V 50-60Hz, W=1/N/PE~100-110V 50-60Hz

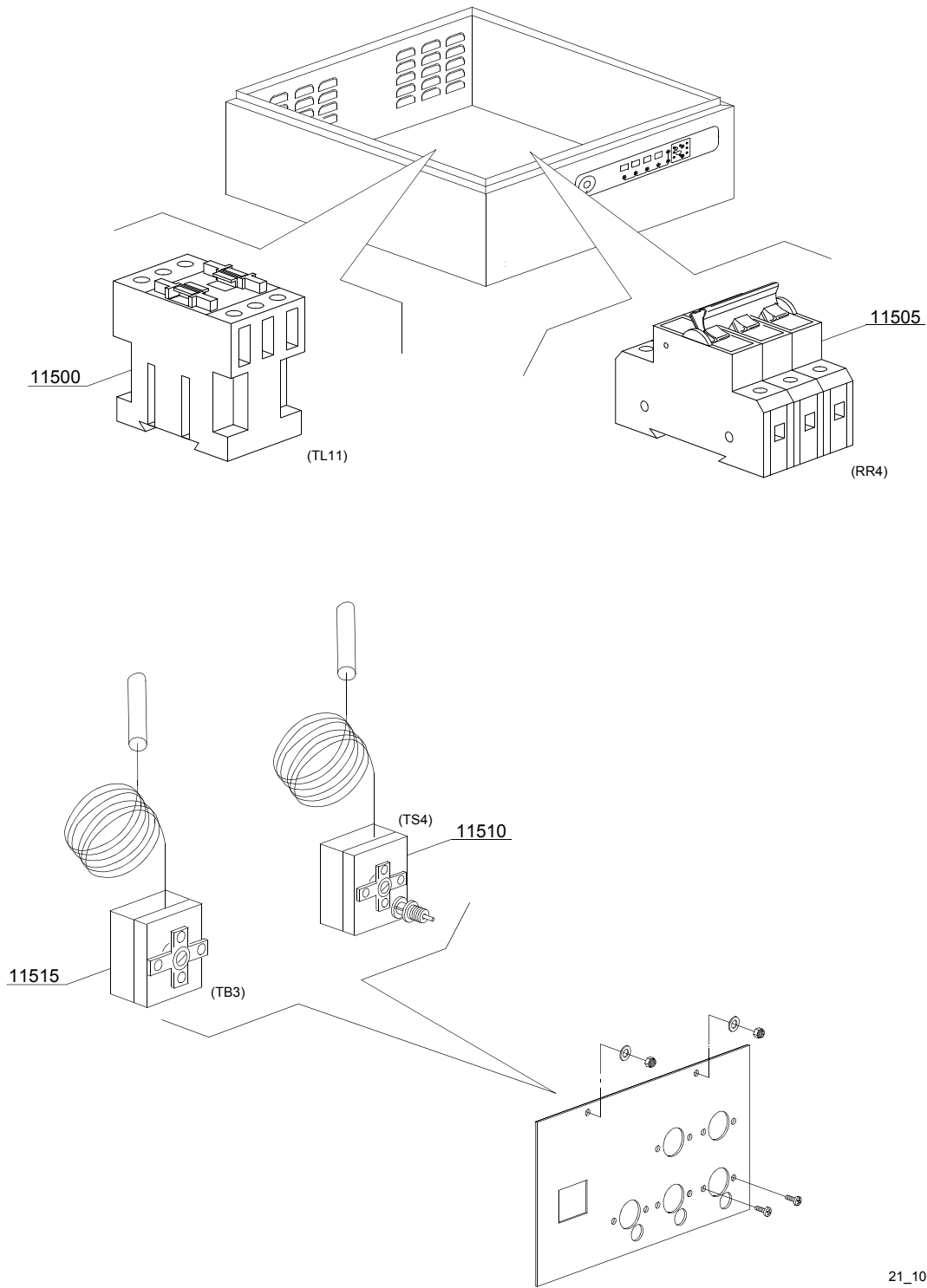

21_101_€

Spare parts

ID	P-code	SN from	SN to	Mod.	Acces.	Volt	Description
Module: Additional boiler: electrical components							
11500	2000380		-	em,uw		A	Contactora BF12 (heating element < 9 kW)
11500	2000385		-	em,uw		A	Contactora BF20 (heating element > 9 kW)
11505	2000403		-	em,uw		A	Automatic fuse C20 (heating element < 9 kW)
11505	2000404		-	em,uw		A	Automatic fuse C25 (heating element > 9 kW)
11510	2000430		-	em,uw			Safety thermostat
11515	10707/1		-	em,uw			Thermostat 0 - 90° (TB2)

em=ELECTROMECHANICAL SWITCHES, uw=LOWER AND UPPER WASHER

39=39

sc9=STEAM CONDENSER - LC 91, csa=CONVEYOR SPEED ADJUSTING - LC 101, 972=90°MOTORIZED CHAIN CONVEYOR - LC 97/2, 973=180°MOTORIZED CHAIN CONVEYOR - LC 97/3, cw=ADDITIONAL BOILER FOR COLD WATER SUPPLY, dvgw=DVGW VALVE SYSTEM, des=DETERGENT ECONOMIZER SYSTEM, ti=TANK INSULATION, ds=DOUBLE SKIN, bp=BOOSTER PUMP, sdn3=DISPENSER SYSTEM SDN-3

A=3/N/PE~380-400V 50-60Hz, D=3/PE~200-210V 50-60Hz, F=2/PE~220-240V 50-60Hz, G=3/N/PE~415V 50-60Hz, H=3/PE~220-230V 50-60Hz, K=3/PE~380-400V 50-60Hz, L=3/PE~415V 50-60Hz, M=3/PE~440V 60Hz, P=1/N/PE~220-230V 50-60Hz, R=2/PE~220-240V 50-60Hz, U=1/N/PE~240V 50-60Hz, V=3/PE~240V 50-60Hz, W=1/N/PE~100-110V 50-60Hz

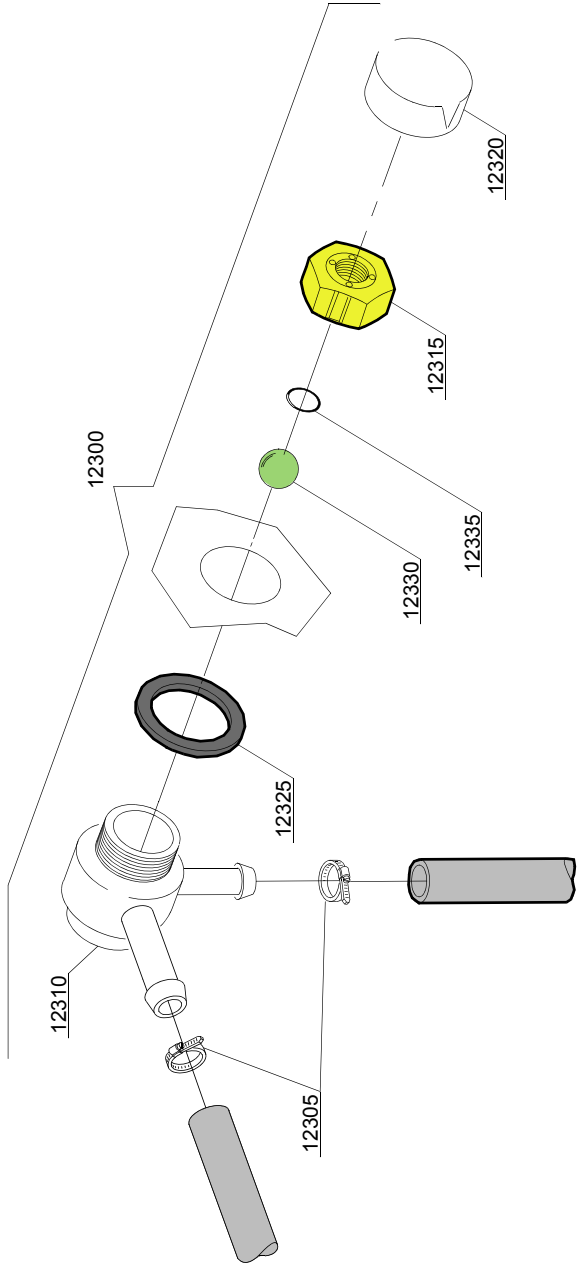

22_002ae

Spare parts

ID	P-code	SN from	SN to	Mod.	Acces.	Volt	Description
Module:DVGW valve							
12300	9891710		-	em,uw			DVGW valvola assembly
12305	11807		-	em,uw			Clamp aisi430 12/22
12310	15280		-	em,uw			Valve body center
12315	15281		-	em,uw			Flat valve
12320	15282		-	em,uw			Flat valve cover
12325	15283		-	em,uw			Valve gasket
12330	15284		-	em,uw			Sphere
12335	15285		-	em,uw			O-ring 115 KTW

em=ELECTROMECHANICAL SWITCHES, uw=LOWER AND UPPER WASHER

39=39

sc9=STEAM CONDENSER - LC 91, csa=CONVEYOR SPEED ADJUSTING - LC 101, 972=90°MOTORIZED CHAIN CONVEYOR - LC 97/2, 973=180°MOTORIZED CHAIN CONVEYOR - LC 97/3, cw=ADDITIONAL BOILER FOR COLD WATER SUPPLY, dvgw=DVGW VALVE SYSTEM, des=DETERGENT ECONOMIZER SYSTEM, ti=TANK INSULATION, ds=DOUBLE SKIN, bp=BOOSTER PUMP, sdn3=DISPENSER SYSTEM SDN-3

A=3/N/PE~380-400V 50-60Hz, D=3/PE~200-210V 50-60Hz, F=2/PE~220-240V 50-60Hz, G=3/N/PE~415V 50-60Hz, H=3/PE~220-230V 50-60Hz, K=3/PE~380-400V 50-60Hz, L=3/PE~415V 50-60Hz, M=3/PE~440V 60Hz, P=1/N/PE~220-230V 50-60Hz, R=2/PE~220-240V 50-60Hz, U=1/N/PE~240V 50-60Hz, V=3/PE~240V 50-60Hz, W=1/N/PE~100-110V 50-60Hz

23_002_e

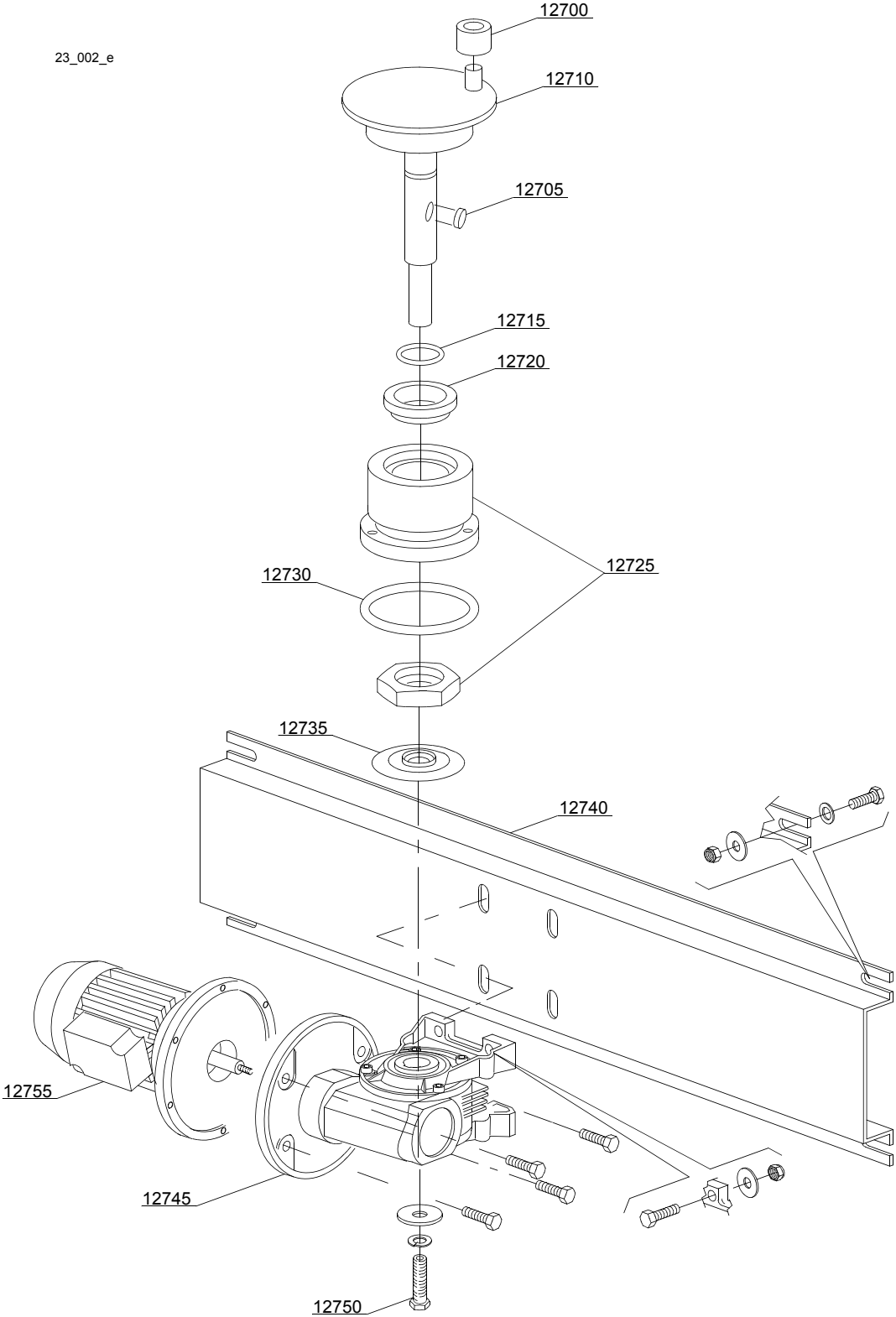

Spare parts

ID	P-code	SN from	SN to	Mod.	Acces.	Volt	Description
Module:Motorgear components module 1300							
12700	3003012		-	em,uw			Conveyor roller
12705	2001046		-	em,uw			Key
12710	3003116		-	em,uw			Crank shaft
12715	13023		-	em,uw			O-ring 131 (4093)
12720	13024		-	em,uw			Oil splash guard DEM 40 TC 30x42x7 with spring
12725	3004131		-	em,uw			Coupling part serie
12730	13015		-	em,uw			O-ring 160 (6225)
12735	3004161		-	em,uw			Protection disk
12740	3009060		-	em,uw			Motorgear support
12745	3000212		-	em,uw			Gear right 1:60 (60Hz)
12745	3000211		-	em,uw			Gear left 1:80
12745	3000216		-	em,uw			Gear right 1:36
12745	3000217		-	em,uw			Gear left 1:36
12750	11165		-	em,uw			Screw
12755	3000107		-	em,uw			Conveyor motor - 6/8P 400V 50Hz - reduced
12755	3000108		-	em,uw			Conveyor motor - 6/8P 230V 50Hz - reduced
12755	3000110		-	em,uw			Conveyor motor - 6/8P 400/415V 50Hz [mod 240,300,310,320,330]
12755	3000109		-	em,uw			Conveyor motor - 6/8P 230V 50Hz [mod 240]

em=ELECTROMECHANICAL SWITCHES, uw=LOWER AND UPPER WASHER

39=39

sc9=STEAM CONDENSER - LC 91, csa=CONVEYOR SPEED ADJUSTING - LC 101, 972=90°MOTORIZED CHAIN CONVEYOR - LC 97/2, 973=180°MOTORIZED CHAIN CONVEYOR - LC 97/3, cw=ADDITIONAL BOILER FOR COLD WATER SUPPLY, dvgw=DVGW VALVE SYSTEM, des=DETERGENT ECONOMIZER SYSTEM, ti=TANK INSULATION, ds=DOUBLE SKIN, bp=BOOSTER PUMP, sdn3=DISPENSER SYSTEM SDN-3

A=3/N/PE~380-400V 50-60Hz, D=3/PE~200-210V 50-60Hz, F=2/PE~220-240V 50-60Hz, G=3/N/PE~415V 50-60Hz, H=3/PE~220-230V 50-60Hz, K=3/PE~380-400V 50-60Hz, L=3/PE~415V 50-60Hz, M=3/PE~440V 60Hz, P=1/N/PE~220-230V 50-60Hz, R=2/PE~220-240V 50-60Hz, U=1/N/PE~240V 50-60Hz, V=3/PE~240V 50-60Hz, W=1/N/PE~100-110V 50-60Hz

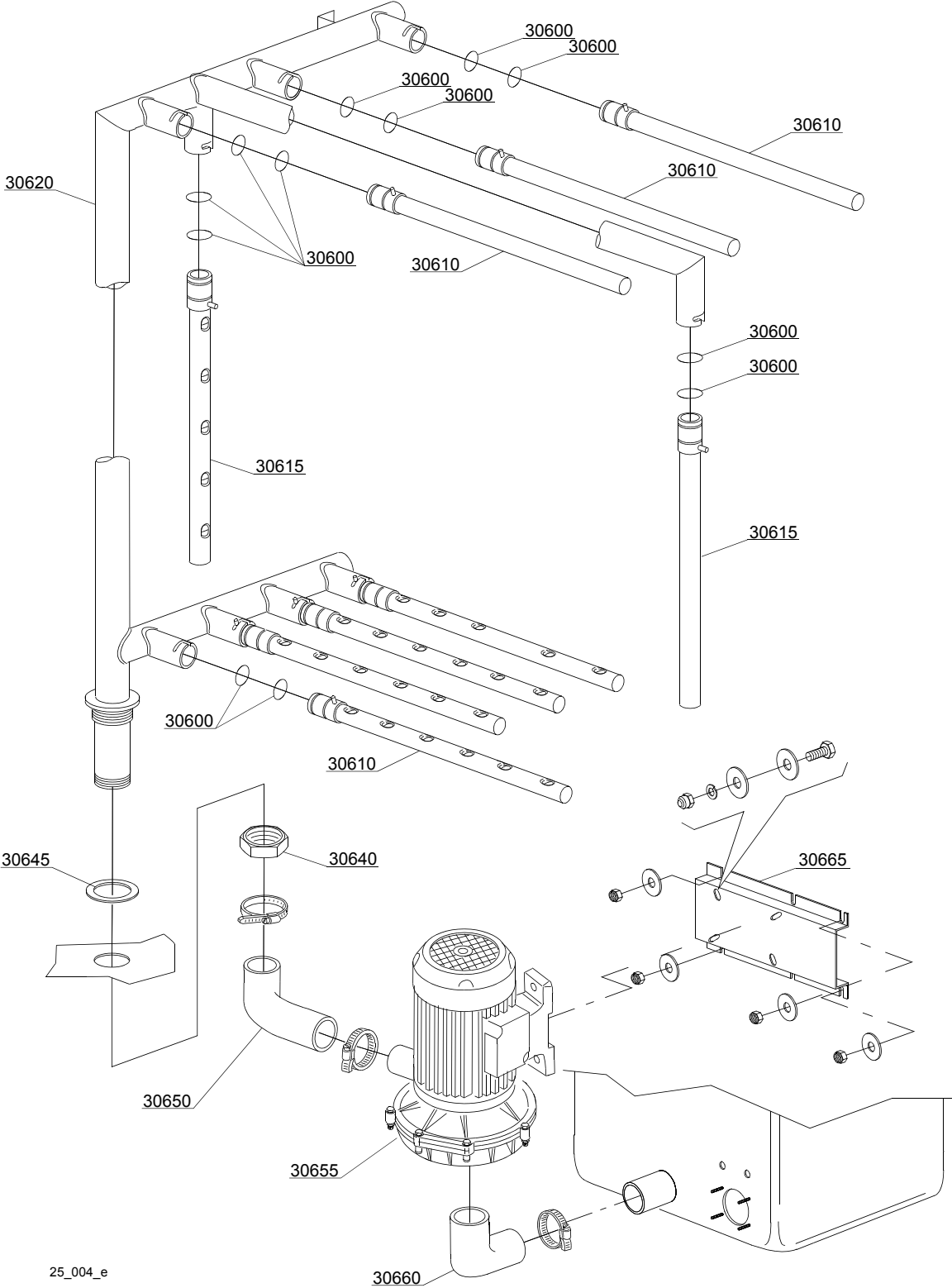

25_004_e

Spare parts

ID	P-code	SN from	SN to	Mod.	Acces.	Volt	Description
Module: Washing components							
30600	13000		-	em,uw			O-ring 3125
30610	3019080		-	em,uw			Horizontal wash arm
30615	3004120		-	em,uw			Vertical wash arm
30620	3004055		-	em,uw			Right wash ramp
30620	3004056		-	em,uw			Left wash ramp
30640	10600012		-	em,uw			Flat nut
30645	10200173/A		-	em,uw			Gasket 75x58x3
30650	3004025		-	em,uw			Elbow coupling press.
30655	80917		-	em,uw		A	Pump 2,6 kW
30660	3002020		-	em,uw			Suction elbow coupling
30665	3009148		-	em,uw			Pump support

em=ELECTROMECHANICAL SWITCHES, uw=LOWER AND UPPER WASHER

39=39

sc9=STEAM CONDENSER - LC 91, csa=CONVEYOR SPEED ADJUSTING - LC 101, 972=90°MOTORIZED CHAIN CONVEYOR - LC 97/2, 973=180°MOTORIZED CHAIN CONVEYOR - LC 97/3, cw=ADDITIONAL BOILER FOR COLD WATER SUPPLY, dvgw=DVGW VALVE SYSTEM, des=DETERGENT ECONOMIZER SYSTEM, ti=TANK INSULATION, ds=DOUBLE SKIN, bp=BOOSTER PUMP, sdn3=DISPENSER SYSTEM SDN-3

A=3/N/PE~380-400V 50-60Hz, D=3/PE~200-210V 50-60Hz, F=2/PE~220-240V 50-60Hz, G=3/N/PE~415V 50-60Hz, H=3/PE~220-230V 50-60Hz, K=3/PE~380-400V 50-60Hz, L=3/PE~415V 50-60Hz, M=3/PE~440V 60Hz, P=1/N/PE~220-230V 50-60Hz, R=2/PE~220-240V 50-60Hz, U=1/N/PE~240V 50-60Hz, V=3/PE~240V 50-60Hz, W=1/N/PE~100-110V 50-60Hz

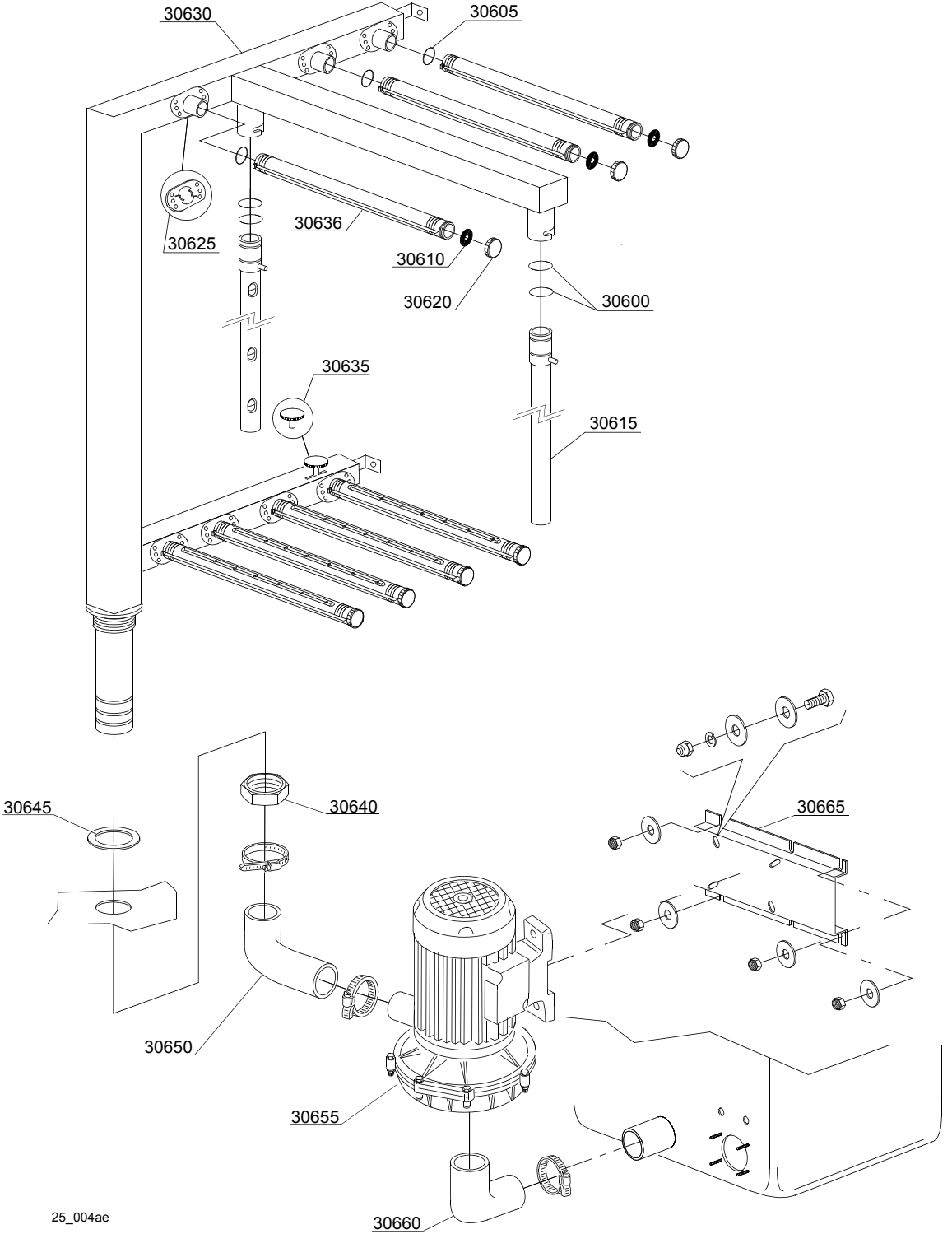

25_004ae

Spare parts

ID	P-code	SN from	SN to	Mod.	Acces.	Volt	Description
Module: Washing components							
30600	13000		-	em,uw			O-ring 3125
30605	13028		-	em,uw			O-ring 3,6x30,8x38 R-23
30610	80305		-	em,uw			Gasket
30615	3004120		-	em,uw			Vertical wash arm
30625	3004148		-	em,uw			Arm connection flange
30630	3004121		-	em,uw			Right wash ramp
30630	3004122		-	em,uw			Left wash ramp
30636	3004147		-	em,uw			Wash arm
30640	10600012		-	em,uw			Flat nut
30645	10200173/A		-	em,uw			Gasket 75x58x3
30650	3004025		-	em,uw			Elbow coupling press.
30655	80917		-	em,uw		A	Pump 2,6 kW
30660	3002020		-	em,uw			Suction elbow coupling
30665	3009148		-	em,uw			Pump support

em=ELECTROMECHANICAL SWITCHES, uw=LOWER AND UPPER WASHER

39=39

sc9=STEAM CONDENSER - LC 91, csa=CONVEYOR SPEED ADJUSTING - LC 101, 972=90°MOTORIZED CHAIN CONVEYOR - LC 97/2, 973=180°MOTORIZED CHAIN CONVEYOR - LC 97/3, cw=ADDITIONAL BOILER FOR COLD WATER SUPPLY, dvgw=DVGW VALVE SYSTEM, des=DETERGENT ECONOMIZER SYSTEM, ti=TANK INSULATION, ds=DOUBLE SKIN, bp=BOOSTER PUMP, sdn3=DISPENSER SYSTEM SDN-3

A=3/N/PE~380-400V 50-60Hz, D=3/PE~200-210V 50-60Hz, F=2/PE~220-240V 50-60Hz, G=3/N/PE~415V 50-60Hz, H=3/PE~220-230V 50-60Hz, K=3/PE~380-400V 50-60Hz, L=3/PE~415V 50-60Hz, M=3/PE~440V 60Hz, P=1/N/PE~220-230V 50-60Hz, R=2/PE~220-240V 50-60Hz, U=1/N/PE~240V 50-60Hz, V=3/PE~240V 50-60Hz, W=1/N/PE~100-110V 50-60Hz

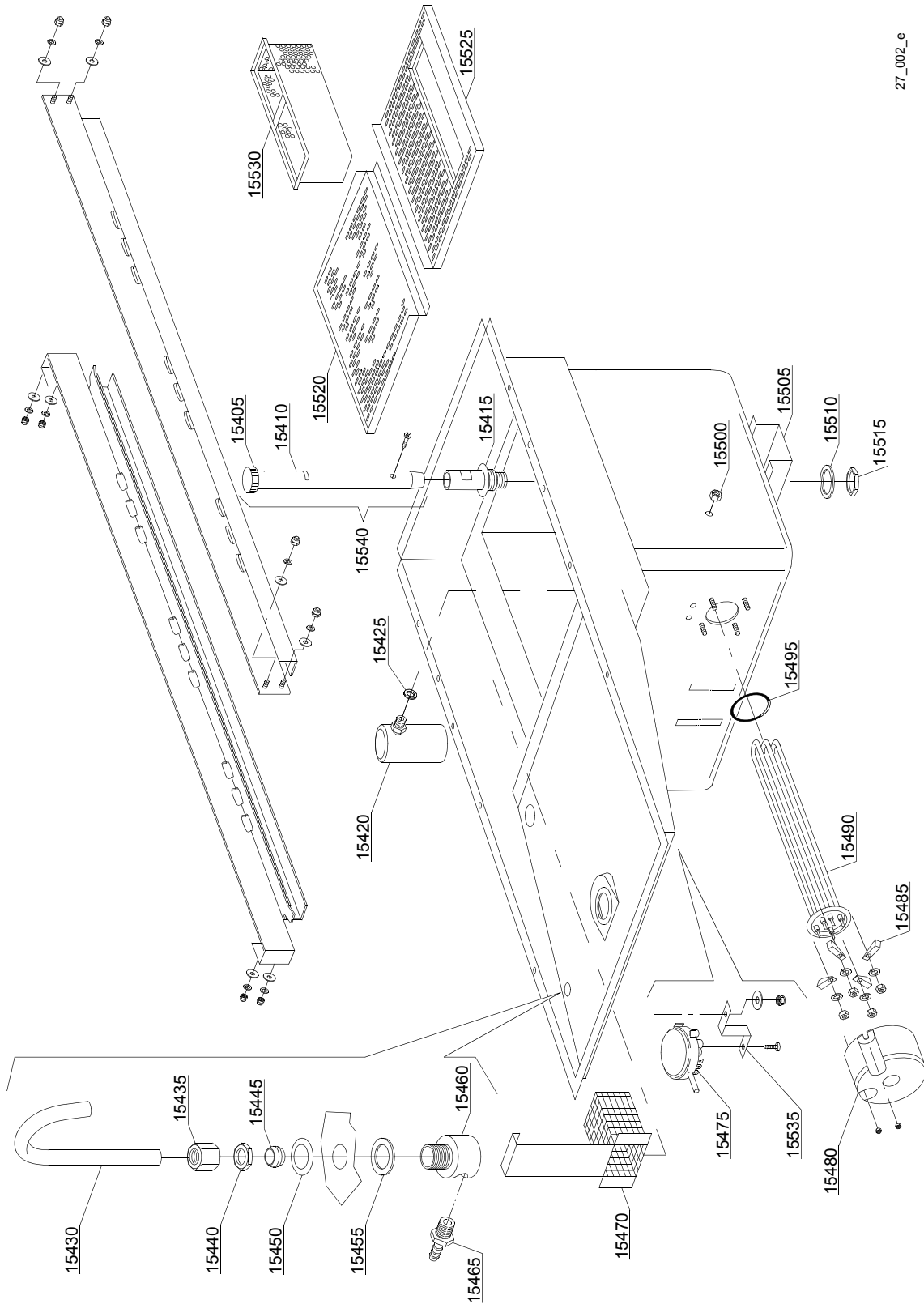

27_002_e

Spare parts

ID	P-code	SN from	SN to	Mod.	Acces.	Volt	Description
Module:Internal components washing module 1300							
15405	88105		-	em,uw			Overflow pipe plug
15410	2000477		-	em,uw			Overflow pipe
15415	3004099		-	em,uw			Overflow device support
15420	80106		-	em,uw			Air trap
15425	13301		-	em,uw			Gasket ROLMART 14x8x1.5
15430	3004054		-	em,uw			Inlet pipe
15435	10600016		-	em,uw			Nut
15440	10200101		-	em,uw			Nut
15445	10200182		-	em,uw			Cone
15450	3009387		-	em,uw			Washer
15455	10200171		-	em,uw			Gasket FASIT 25x17x2
15460	80231		-	em,uw			Fitting
15465	12005		-	em,uw			Hose holder
15470	3019071		-	em,uw			Pump suction-filter
15475	88110		-	em,uw			Pressure switch (260-30)
15480	75311		-	em,uw			Heating element cover
15485	16045		-	em,uw			Heating element support Ø6.3
15490	30001011		-	em,uw		A	Heating element 9kW
15490	30001011/A		-	em,uw		A	Heating element 12kW
15490	30001011/B		-	em,uw		A	Heating element 14kW
15495	13015		-	em,uw			O-ring 160 (6225)
15500	11702		-	em,uw			Nut
15505	3009299		-	em,uw			Tank support
15510	10200173		-	em,uw			Gasket 75x58x3
15515	10600012		-	em,uw			Flat nut
15520	3009567		-	em,uw			Strainer plate, back
15525	3019074		-	em,uw			Strainer plate front
15530	3019065		-	em,uw			Scrap tray

em=ELECTROMECHANICAL SWITCHES, uw=LOWER AND UPPER WASHER

39=39

sc9=STEAM CONDENSER - LC 91, csa=CONVEYOR SPEED ADJUSTING - LC 101, 972=90°MOTORIZED CHAIN CONVEYOR - LC 97/2, 973=180°MOTORIZED CHAIN CONVEYOR - LC 97/3, cw=ADDITIONAL BOILER FOR COLD WATER SUPPLY, dvgw=DVGW VALVE SYSTEM, des=DETERGENT ECONOMIZER SYSTEM, ti=TANK INSULATION, ds=DOUBLE SKIN, bp=BOOSTER PUMP, sdn3=DISPENSER SYSTEM SDN-3

A=3/N/PE~380-400V 50-60Hz, D=3/PE~200-210V 50-60Hz, F=2/PE~220-240V 50-60Hz, G=3/N/PE~415V 50-60Hz, H=3/PE~220-230V 50-60Hz, K=3/PE~380-400V 50-60Hz, L=3/PE~415V 50-60Hz, M=3/PE~440V 60Hz, P=1/N/PE~220-230V 50-60Hz, R=2/PE~220-240V 50-60Hz, U=1/N/PE~240V 50-60Hz, V=3/PE~240V 50-60Hz, W=1/N/PE~100-110V 50-60Hz

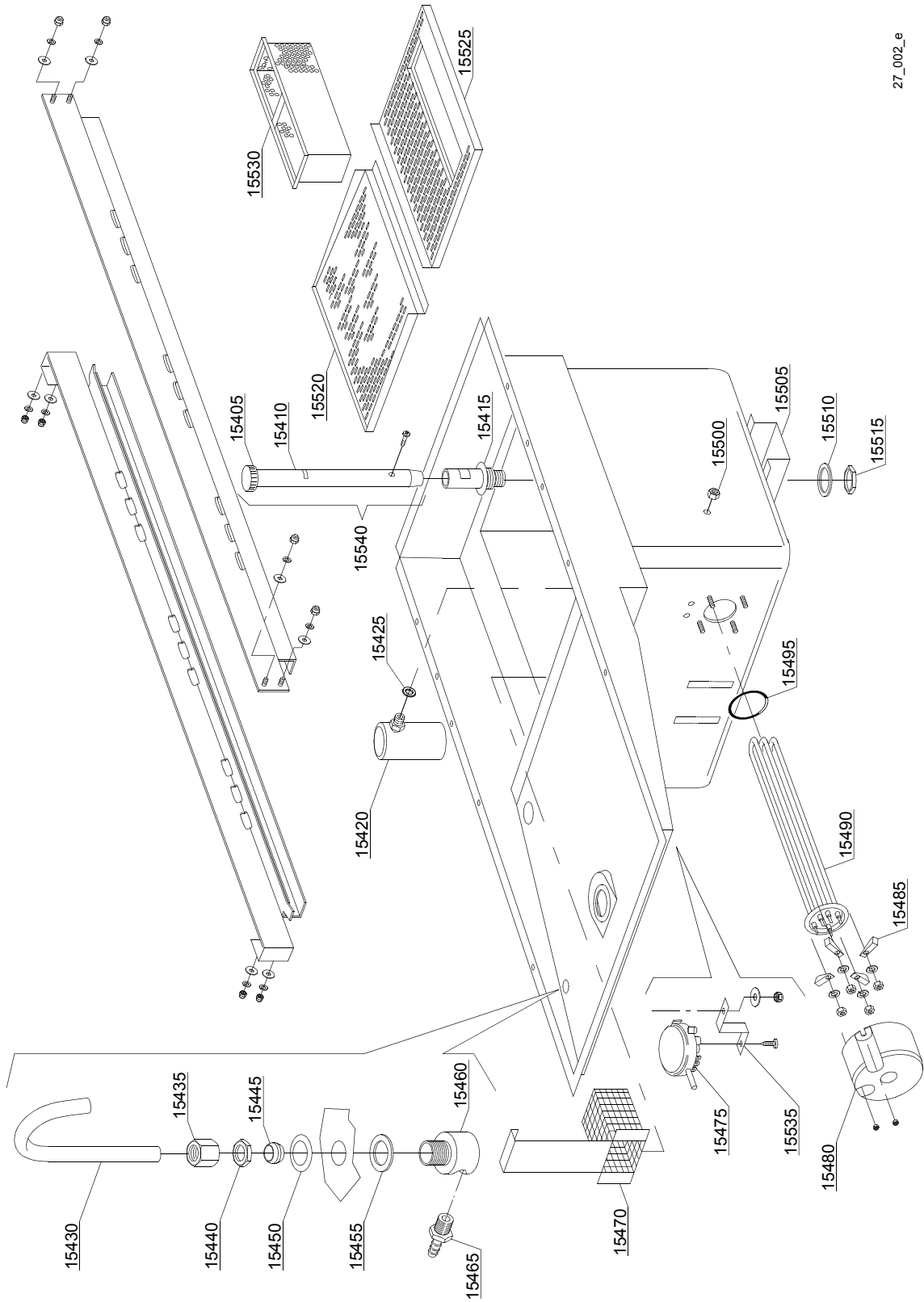

27_002_e

Spare parts

ID	P-code	SN from	SN to	Mod.	Acces.	Volt	Description
Module: Internal components washing module 1300							
15535	3009363		-	em,uw			Pressure switch support
15540	3004101			em,uw			Overflow pipe assembly

em=ELECTROMECHANICAL SWITCHES, uw=LOWER AND UPPER WASHER

39=39

sc9=STEAM CONDENSER - LC 91, csa=CONVEYOR SPEED ADJUSTING - LC 101, 972=90°MOTORIZED CHAIN CONVEYOR - LC 97/2, 973=180°MOTORIZED CHAIN CONVEYOR - LC 97/3, cw=ADDITIONAL BOILER FOR COLD WATER SUPPLY, dvgw=DVGW VALVE SYSTEM, des=DETERGENT ECONOMIZER SYSTEM, ti=TANK INSULATION, ds=DOUBLE SKIN, bp=BOOSTER PUMP, sdn3=DISPENSER SYSTEM SDN-3

A=3/N/PE~380-400V 50-60Hz, D=3/PE~200-210V 50-60Hz, F=2/PE~220-240V 50-60Hz, G=3/N/PE~415V 50-60Hz, H=3/PE~220-230V 50-60Hz, K=3/PE~380-400V 50-60Hz, L=3/PE~415V 50-60Hz, M=3/PE~440V 60Hz, P=1/N/PE~220-230V 50-60Hz, R=2/PE~220-240V 50-60Hz, U=1/N/PE~240V 50-60Hz, V=3/PE~240V 50-60Hz, W=1/N/PE~100-110V 50-60Hz

28_003_e

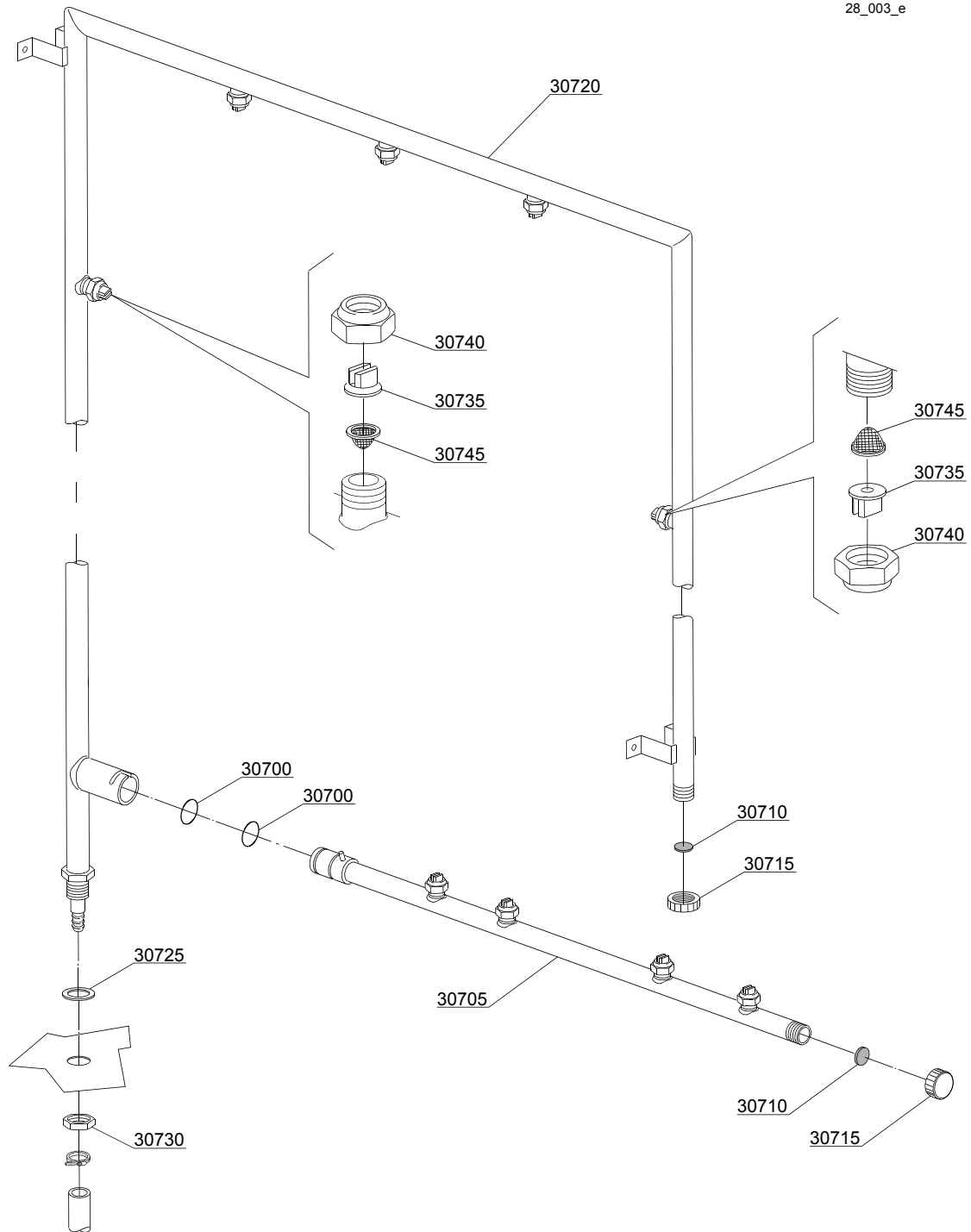

Spare parts

ID	P-code	SN from	SN to	Mod.	Acces.	Volt	Description
Module:Rinsing components							
30700	13025		-	em,uw			O-ring 2081
30705	3003080		-	em,uw			Rinsing arm 4n
30710	2002051		-	em,uw			Gasket EPDM 17.5x1.5
30715	2002054		-	em,uw			Plug for arm
30720	3004123		-	em,uw			Rinsing ramp
30725	13326		-	em,uw			Gasket 38x27x2
30730	2200103		-	em,uw			Nut
30735	2200114		-	em,uw			Nozzle
30740	2200116		-	em,uw			Nut
30745	2200117		-	em,uw			Filter

em=ELECTROMECHANICAL SWITCHES, uw=LOWER AND UPPER WASHER

39=39

sc9=STEAM CONDENSER - LC 91, csa=CONVEYOR SPEED ADJUSTING - LC 101, 972=90°MOTORIZED CHAIN CONVEYOR - LC 97/2, 973=180°MOTORIZED CHAIN CONVEYOR - LC 97/3, cw=ADDITIONAL BOILER FOR COLD WATER SUPPLY, dvgw=DVGW VALVE SYSTEM, des=DETERGENT ECONOMIZER SYSTEM, ti=TANK INSULATION, ds=DOUBLE SKIN, bp=BOOSTER PUMP, sdn3=DISPENSER SYSTEM SDN-3

A=3/N/PE~380-400V 50-60Hz, D=3/PE~200-210V 50-60Hz, F=2/PE~220-240V 50-60Hz, G=3/N/PE~415V 50-60Hz, H=3/PE~220-230V 50-60Hz, K=3/PE~380-400V 50-60Hz, L=3/PE~415V 50-60Hz, M=3/PE~440V 60Hz, P=1/N/PE~220-230V 50-60Hz, R=2/PE~220-240V 50-60Hz, U=1/N/PE~240V 50-60Hz, V=3/PE~240V 50-60Hz, W=1/N/PE~100-110V 50-60Hz

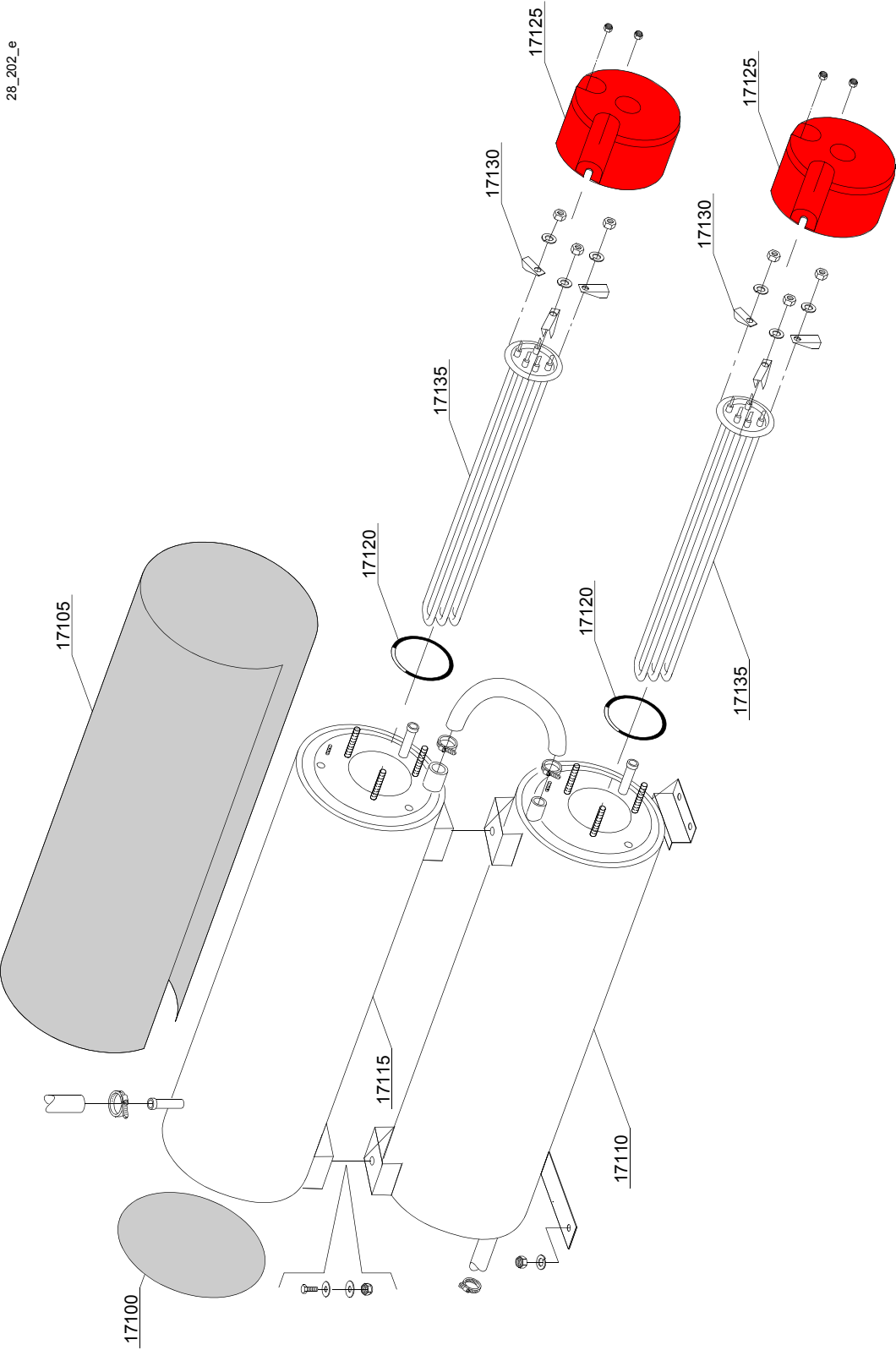

28_202_e

Spare parts

ID	P-code	SN from	SN to	Mod.	Acces.	Volt	Description
Module:Boiler components							
17100	75205		-	em,uw			Bottom boiler insulating
17105	30002030		-	em,uw			Boiler insulating
17110	3007012		-	em,uw			Inferior Boiler
17115	3007013		-	em,uw			Upper Boiler
17120	13015		-	em,uw			O-ring 160 (6225)
17125	75311		-	em,uw			Heating element cover
17130	16045		-	em,uw			Heating element support Ø6.3
17135	30001011		-	em,uw		A	Heating element 9kW
17135	30001011/A		-	em,uw		A	Heating element 12kW
17135	30001011/B		-	em,uw		A	Heating element 14kW

em=ELECTROMECHANICAL SWITCHES, uw=LOWER AND UPPER WASHER

39=39

sc9=STEAM CONDENSER - LC 91, csa=CONVEYOR SPEED ADJUSTING - LC 101, 972=90°MOTORIZED CHAIN CONVEYOR - LC 97/2, 973=180°MOTORIZED CHAIN CONVEYOR - LC 97/3, cw=ADDITIONAL BOILER FOR COLD WATER SUPPLY, dvgw=DVGW VALVE SYSTEM, des=DETERGENT ECONOMIZER SYSTEM, ti=TANK INSULATION, ds=DOUBLE SKIN, bp=BOOSTER PUMP, sdn3=DISPENSER SYSTEM SDN-3

A=3/N/PE~380-400V 50-60Hz, D=3/PE~200-210V 50-60Hz, F=2/PE~220-240V 50-60Hz, G=3/N/PE~415V 50-60Hz, H=3/PE~220-230V 50-60Hz, K=3/PE~380-400V 50-60Hz, L=3/PE~415V 50-60Hz, M=3/PE~440V 60Hz, P=1/N/PE~220-230V 50-60Hz, R=2/PE~220-240V 50-60Hz, U=1/N/PE~240V 50-60Hz, V=3/PE~240V 50-60Hz, W=1/N/PE~100-110V 50-60Hz

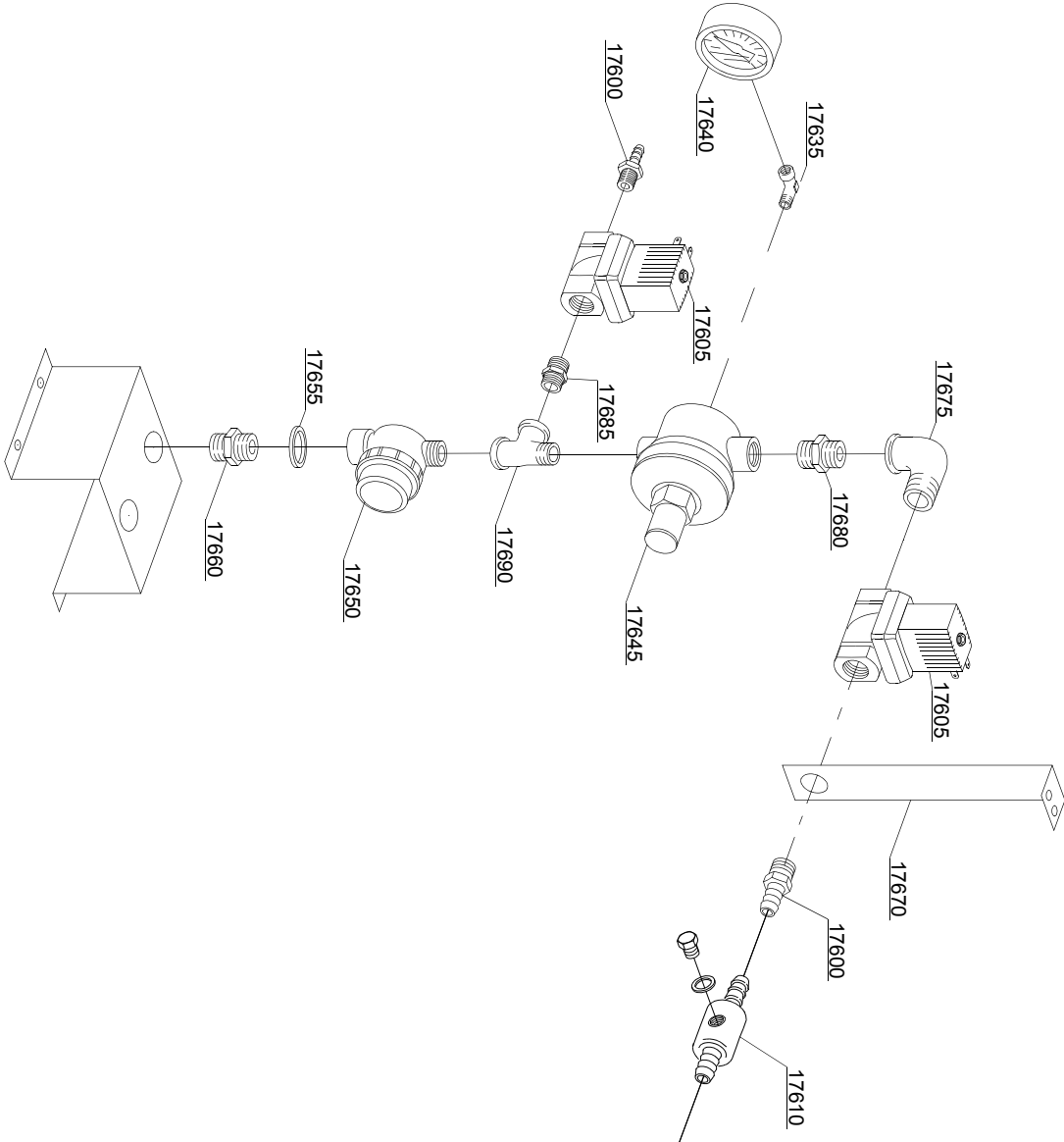

29_003_e

Spare parts

ID	P-code	SN from	SN to	Mod.	Acces.	Volt	Description
Module:Solenoid valves components: tank loading + rinsing							
17600	12023		-	em,uw			Hose holder
17605	3002030		-	em,uw			Solenoid valve
17610	3003906		-	em,uw			Connection T
17635	12012		-	em,uw			Elbow
17640	2000244		-	em,uw			Pressure reduction gauge
17645	2000364		-	em,uw			Pressure reduction valve
17650	2000121		-	em,uw			Filter
17655	13326		-	em,uw			Gasket 38x27x2
17660	12025		-	em,uw			Nipples
17665	12033		-	em,uw			Nipples
17670	3009585		-	em,uw			Solenoid valve support
17675	3002141		-	em,uw			Elbow
17680	10200208		-	em,uw			Nipples
17685	3002145		-	em,uw			Reduction nipples
17690	3002144		-	em,uw			Connection T

em=ELECTROMECHANICAL SWITCHES, uw=LOWER AND UPPER WASHER

39=39

sc9=STEAM CONDENSER - LC 91, csa=CONVEYOR SPEED ADJUSTING - LC 101, 972=90°MOTORIZED CHAIN CONVEYOR - LC 97/2, 973=180°MOTORIZED CHAIN CONVEYOR - LC 97/3, cw=ADDITIONAL BOILER FOR COLD WATER SUPPLY, dvgw=DVGW VALVE SYSTEM, des=DETERGENT ECONOMIZER SYSTEM, ti=TANK INSULATION, ds=DOUBLE SKIN, bp=BOOSTER PUMP, sdn3=DISPENSER SYSTEM SDN-3

A=3/N/PE~380-400V 50-60Hz, D=3/PE~200-210V 50-60Hz, F=2/PE~220-240V 50-60Hz, G=3/N/PE~415V 50-60Hz, H=3/PE~220-230V 50-60Hz, K=3/PE~380-400V 50-60Hz, L=3/PE~415V 50-60Hz, M=3/PE~440V 60Hz, P=1/N/PE~220-230V 50-60Hz, R=2/PE~220-240V 50-60Hz, U=1/N/PE~240V 50-60Hz, V=3/PE~240V 50-60Hz, W=1/N/PE~100-110V 50-60Hz

29_004ae

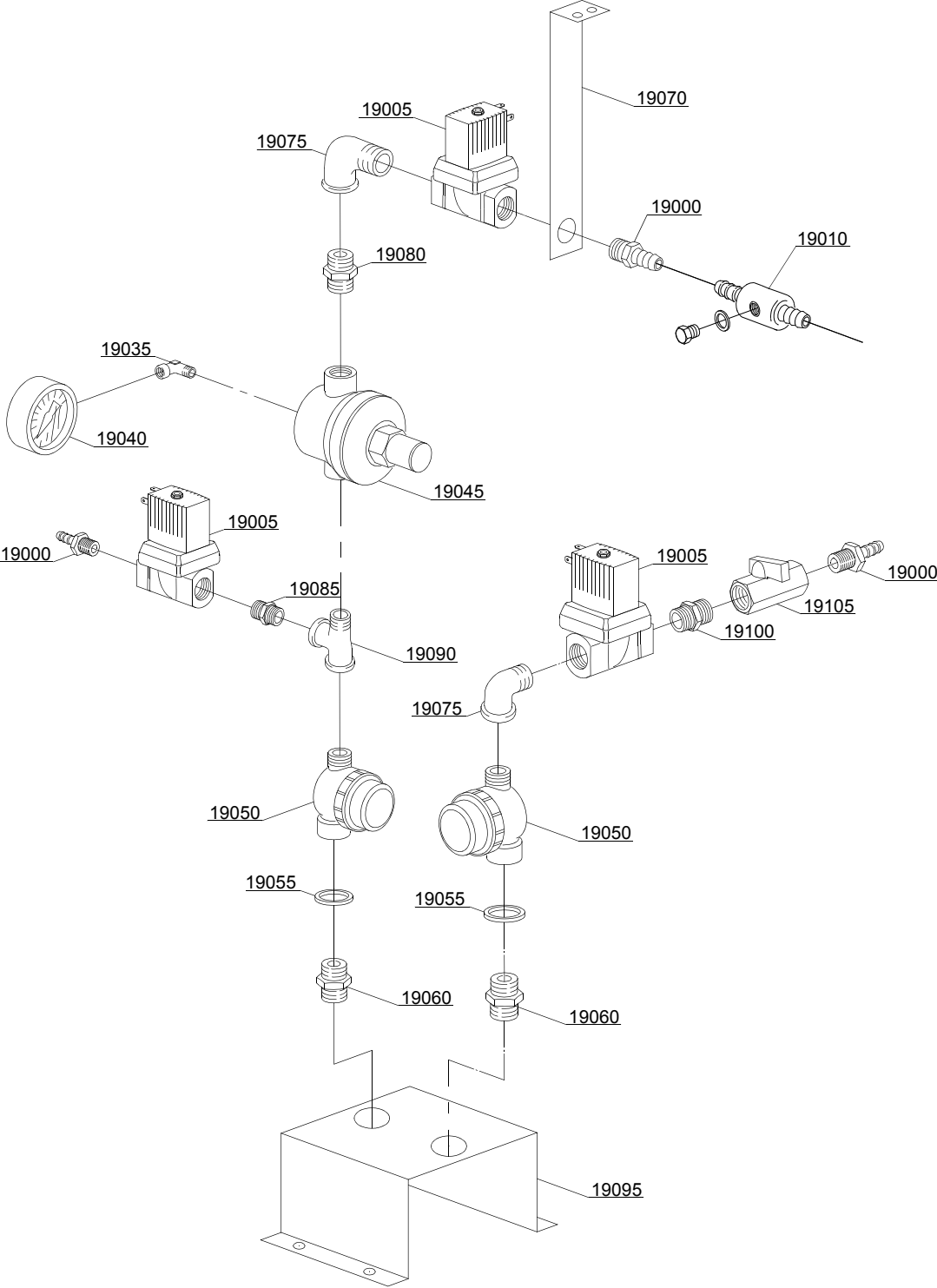

Spare parts

ID	P-code	SN from	SN to	Mod.	Acces.	Volt	Description
Module:Solenoid valves components: tank loading + rinsing + steam condenser							
19000	12023		-	em,uw			Hose holder
19005	3002030		-	em,uw			Solenoid valve
19010	3003906		-	em,uw			Connection T
19035	12012		-	em,uw			Elbow
19040	2000244		-	em,uw			Pressure reduction gauge
19045	2000364		-	em,uw			Pressure reduction valve
19050	2000121		-	em,uw			Filter
19055	13326		-	em,uw			Gasket 38x27x2
19060	12025		-	em,uw			Nipples
19065	12033		-	em,uw			Nipples
19070	3009585		-	em,uw			Solenoid valve support
19075	3002141		-	em,uw			Elbow
19080	10200208		-	em,uw			Nipples
19085	3002145		-	em,uw			Reduction nipples
19090	3002144		-	em,uw			Connection T
19095	3009220		-	em,uw			Solenoid valve support
19100	12027		-	em,uw			Nipples
19105	3002140		-	em,uw			Tap

em=ELECTROMECHANICAL SWITCHES, uw=LOWER AND UPPER WASHER

39=39

sc9=STEAM CONDENSER - LC 91, csa=CONVEYOR SPEED ADJUSTING - LC 101, 972=90°MOTORIZED CHAIN CONVEYOR - LC 97/2, 973=180°MOTORIZED CHAIN CONVEYOR - LC 97/3, cw=ADDITIONAL BOILER FOR COLD WATER SUPPLY, dvgw=DVGW VALVE SYSTEM, des=DETERGENT ECONOMIZER SYSTEM, ti=TANK INSULATION, ds=DOUBLE SKIN, bp=BOOSTER PUMP, sdn3=DISPENSER SYSTEM SDN-3

A=3/N/PE~380-400V 50-60Hz, D=3/PE~200-210V 50-60Hz, F=2/PE~220-240V 50-60Hz, G=3/N/PE~415V 50-60Hz, H=3/PE~220-230V 50-60Hz, K=3/PE~380-400V 50-60Hz, L=3/PE~415V 50-60Hz, M=3/PE~440V 60Hz, P=1/N/PE~220-230V 50-60Hz, R=2/PE~220-240V 50-60Hz, U=1/N/PE~240V 50-60Hz, V=3/PE~240V 50-60Hz, W=1/N/PE~100-110V 50-60Hz

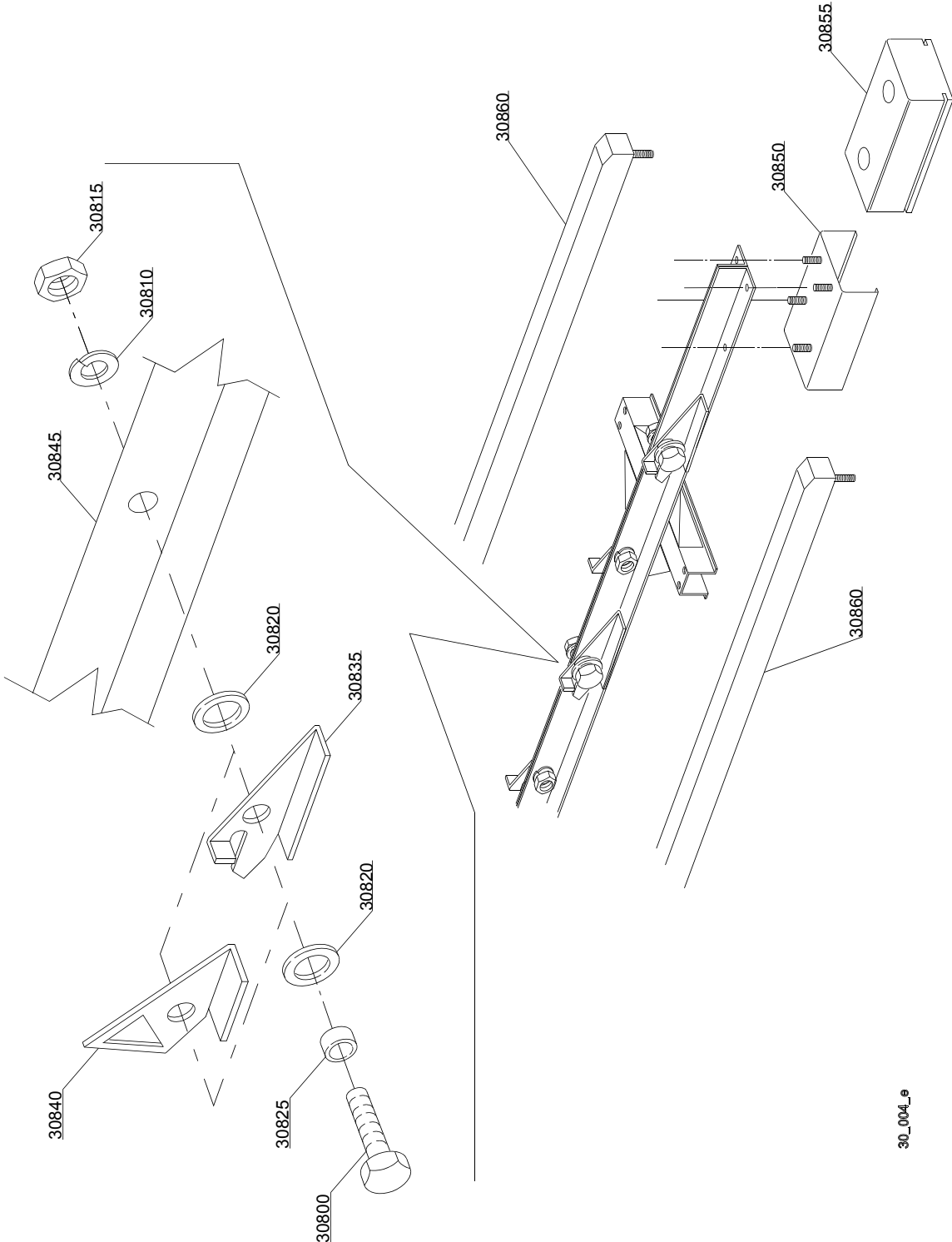

30_004_e

Spare parts

ID	P-code	SN from	SN to	Mod.	Acces.	Volt	Description
Module:Conveyor parts							
30800	11109		-	em,uw			Screw
30810	11609		-	em,uw			Split washer
30815	11719		-	em,uw			Nut
30820	3003024		-	em,uw			Washer
30825	3003025		-	em,uw			Bush
30835	3003100		-	em,uw			Clip right
30835	3003101		-	em,uw			Clip left
30840	3003102		-	em,uw			Right pawl
30840	3003103		-	em,uw			Left pawl
30845	3009132		-	em,uw			Right mobile frame
30845	3009133		-	em,uw			Left mobile frame
30850	3009358		-	em,uw			Guide
30855	3003068		-	em,uw			Mobile frame sliding guide
30860	3009668		-	em,uw			Internal slide

em=ELECTROMECHANICAL SWITCHES, uw=LOWER AND UPPER WASHER

39=39

sc9=STEAM CONDENSER - LC 91, csa=CONVEYOR SPEED ADJUSTING - LC 101, 972=90°MOTORIZED CHAIN CONVEYOR - LC 97/2, 973=180°MOTORIZED CHAIN CONVEYOR - LC 97/3, cw=ADDITIONAL BOILER FOR COLD WATER SUPPLY, dvgw=DVGW VALVE SYSTEM, des=DETERGENT ECONOMIZER SYSTEM, ti=TANK INSULATION, ds=DOUBLE SKIN, bp=BOOSTER PUMP, sdn3=DISPENSER SYSTEM SDN-3

A=3/N/PE~380-400V 50-60Hz, D=3/PE~200-210V 50-60Hz, F=2/PE~220-240V 50-60Hz, G=3/N/PE~415V 50-60Hz, H=3/PE~220-230V 50-60Hz, K=3/PE~380-400V 50-60Hz, L=3/PE~415V 50-60Hz, M=3/PE~440V 60Hz, P=1/N/PE~220-230V 50-60Hz, R=2/PE~220-240V 50-60Hz, U=1/N/PE~240V 50-60Hz, V=3/PE~240V 50-60Hz, W=1/N/PE~100-110V 50-60Hz

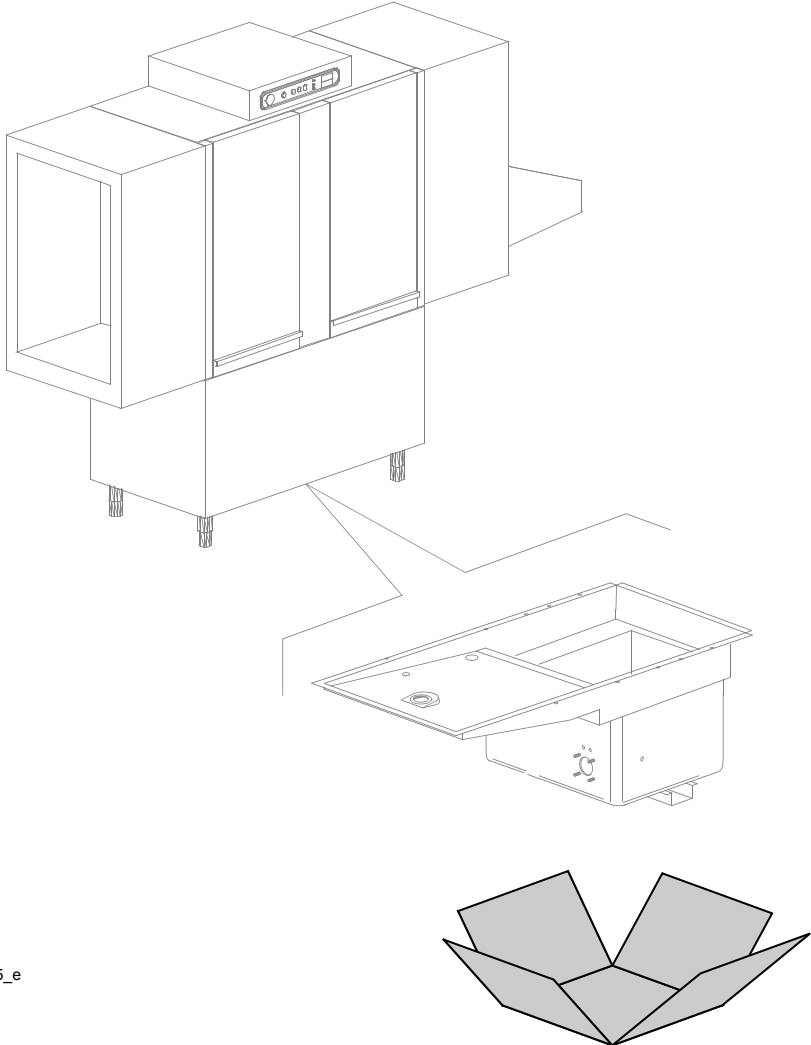

36_015_e

Spare parts

ID	P-code	SN from	SN to	Mod.	Acces.	Volt	Description
Module: Tank insulation							
999	999910207		-	em,uw	ti		Tank insulation N.B.: kit suppliable only together with the machine, not after

em=ELECTROMECHANICAL SWITCHES, uw=LOWER AND UPPER WASHER

39=39

sc9=STEAM CONDENSER - LC 91, csa=CONVEYOR SPEED ADJUSTING - LC 101, 972=90°MOTORIZED CHAIN CONVEYOR - LC 97/2, 973=180°MOTORIZED CHAIN CONVEYOR - LC 97/3, cw=ADDITIONAL BOILER FOR COLD WATER SUPPLY, dvgw=DVGW VALVE SYSTEM, des=DETERGENT ECONOMIZER SYSTEM, ti=TANK INSULATION, ds=DOUBLE SKIN, bp=BOOSTER PUMP, sdn3=DISPENSER SYSTEM SDN-3

A=3/N/PE~380-400V 50-60Hz, D=3/PE~200-210V 50-60Hz, F=2/PE~220-240V 50-60Hz, G=3/N/PE~415V 50-60Hz, H=3/PE~220-230V 50-60Hz, K=3/PE~380-400V 50-60Hz, L=3/PE~415V 50-60Hz, M=3/PE~440V 60Hz, P=1/N/PE~220-230V 50-60Hz, R=2/PE~220-240V 50-60Hz, U=1/N/PE~240V 50-60Hz, V=3/PE~240V 50-60Hz, W=1/N/PE~100-110V 50-60Hz

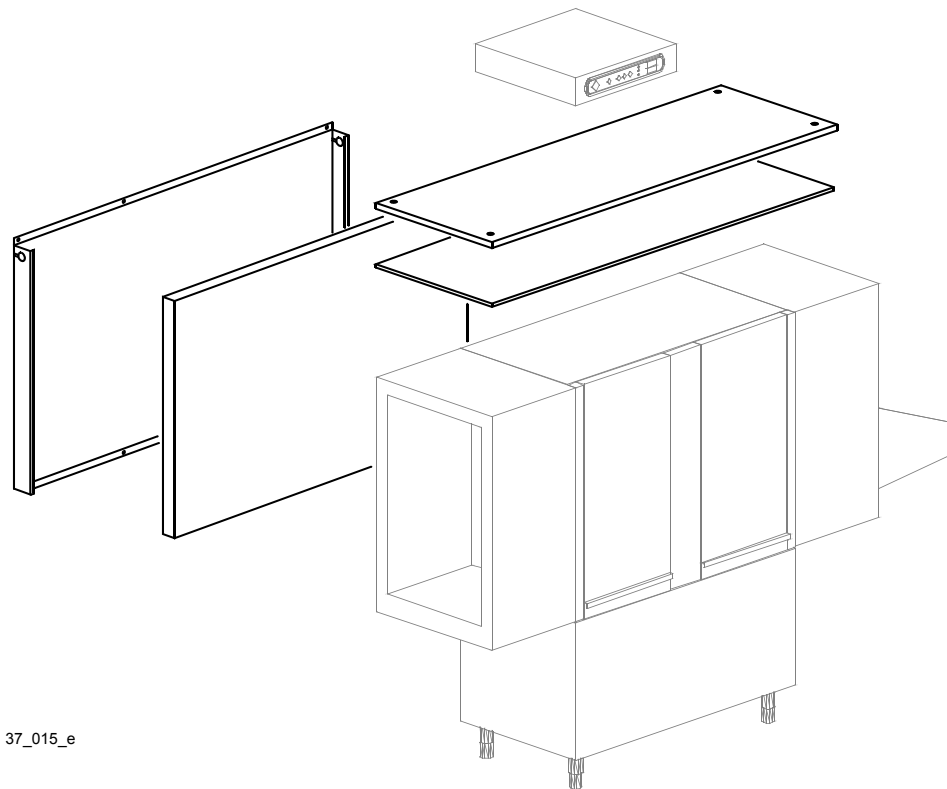

37_015_e

Spare parts

ID	P-code	SN from	SN to	Mod.	Acces.	Volt	Description
Module:Double skin							
999	999910206		-	em,uw	ds		Double skin assembly
							N.B.: kit suppliable only together with the machine, not after

em=ELECTROMECHANICAL SWITCHES, uw=LOWER AND UPPER WASHER

39=39

sc9=STEAM CONDENSER - LC 91, csa=CONVEYOR SPEED ADJUSTING - LC 101, 972=90°MOTORIZED CHAIN CONVEYOR - LC 97/2, 973=180°MOTORIZED CHAIN CONVEYOR - LC 97/3, cw=ADDITIONAL BOILER FOR COLD WATER SUPPLY, dvgw=DVGW VALVE SYSTEM, des=DETERGENT ECONOMIZER SYSTEM, ti=TANK INSULATION, ds=DOUBLE SKIN, bp=BOOSTER PUMP, sdn3=DISPENSER SYSTEM SDN-3

A=3/N/PE~380-400V 50-60Hz, D=3/PE~200-210V 50-60Hz, F=2/PE~220-240V 50-60Hz, G=3/N/PE~415V 50-60Hz, H=3/PE~220-230V 50-60Hz, K=3/PE~380-400V 50-60Hz, L=3/PE~415V 50-60Hz, M=3/PE~440V 60Hz, P=1/N/PE~220-230V 50-60Hz, R=2/PE~220-240V 50-60Hz, U=1/N/PE~240V 50-60Hz, V=3/PE~240V 50-60Hz, W=1/N/PE~100-110V 50-60Hz

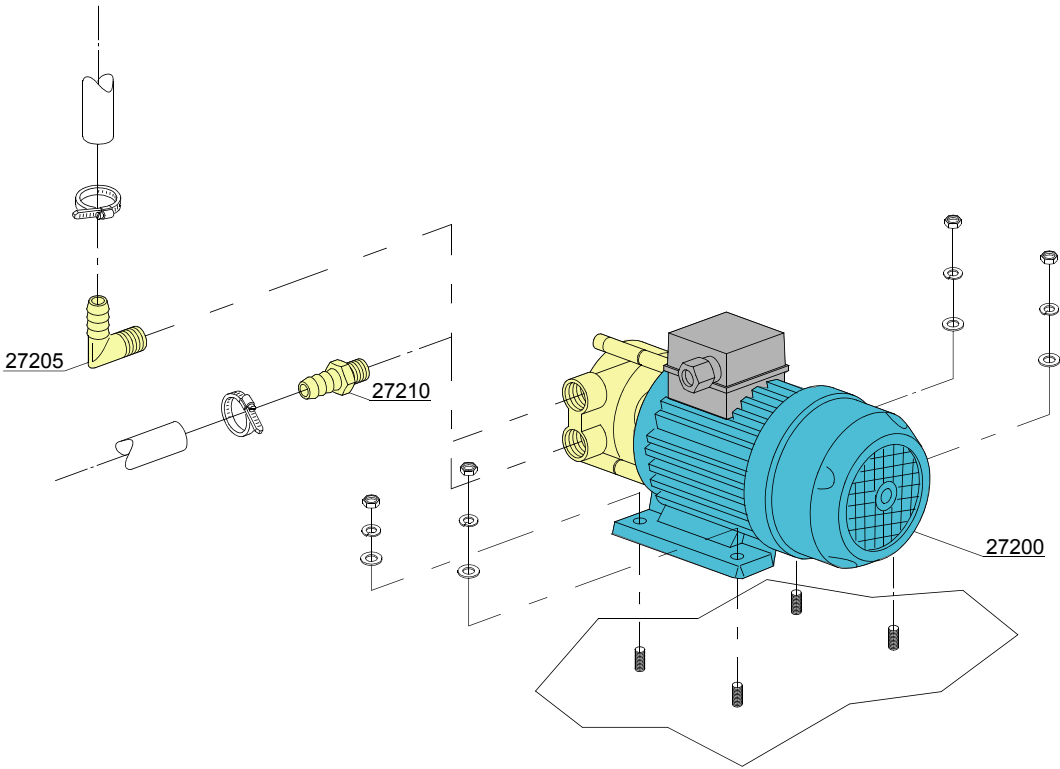
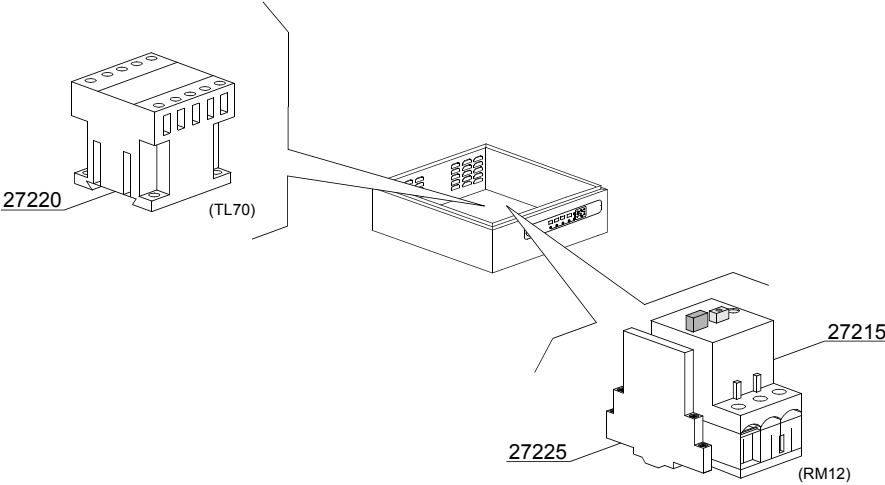

38_001_e

Spare parts

ID	P-code	SN from	SN to	Mod.	Acces.	Volt	Description
Module:Booster pump							
27200	15100		-		bp		Booster pump
27205	12030		-		bp		Elbow pipe fitting
27210	10221311		-		bp		Pipe fitting
27215	2000394		-		bp		Motorprotector 2,5-4A
27220	2000370		-		bp		Contactactor MC9
27225	3006080		-		bp		Auxiliary contact LMS25

em=ELECTROMECHANICAL SWITCHES, uw=LOWER AND UPPER WASHER

39=39

sc9=STEAM CONDENSER - LC 91, csa=CONVEYOR SPEED ADJUSTING - LC 101, 972=90°MOTORIZED CHAIN CONVEYOR - LC 97/2, 973=180°MOTORIZED CHAIN CONVEYOR - LC 97/3, cw=ADDITIONAL BOILER FOR COLD WATER SUPPLY, dvgw=DVGW VALVE SYSTEM, des=DETERGENT ECONOMIZER SYSTEM, ti=TANK INSULATION, ds=DOUBLE SKIN, bp=BOOSTER PUMP, sdn3=DISPENSER SYSTEM SDN-3

A=3/N/PE~380-400V 50-60Hz, D=3/PE~200-210V 50-60Hz, F=2/PE~220-240V 50-60Hz, G=3/N/PE~415V 50-60Hz, H=3/PE~220-230V 50-60Hz, K=3/PE~380-400V 50-60Hz, L=3/PE~415V 50-60Hz, M=3/PE~440V 60Hz, P=1/N/PE~220-230V 50-60Hz, R=2/PE~220-240V 50-60Hz, U=1/N/PE~240V 50-60Hz, V=3/PE~240V 50-60Hz, W=1/N/PE~100-110V 50-60Hz

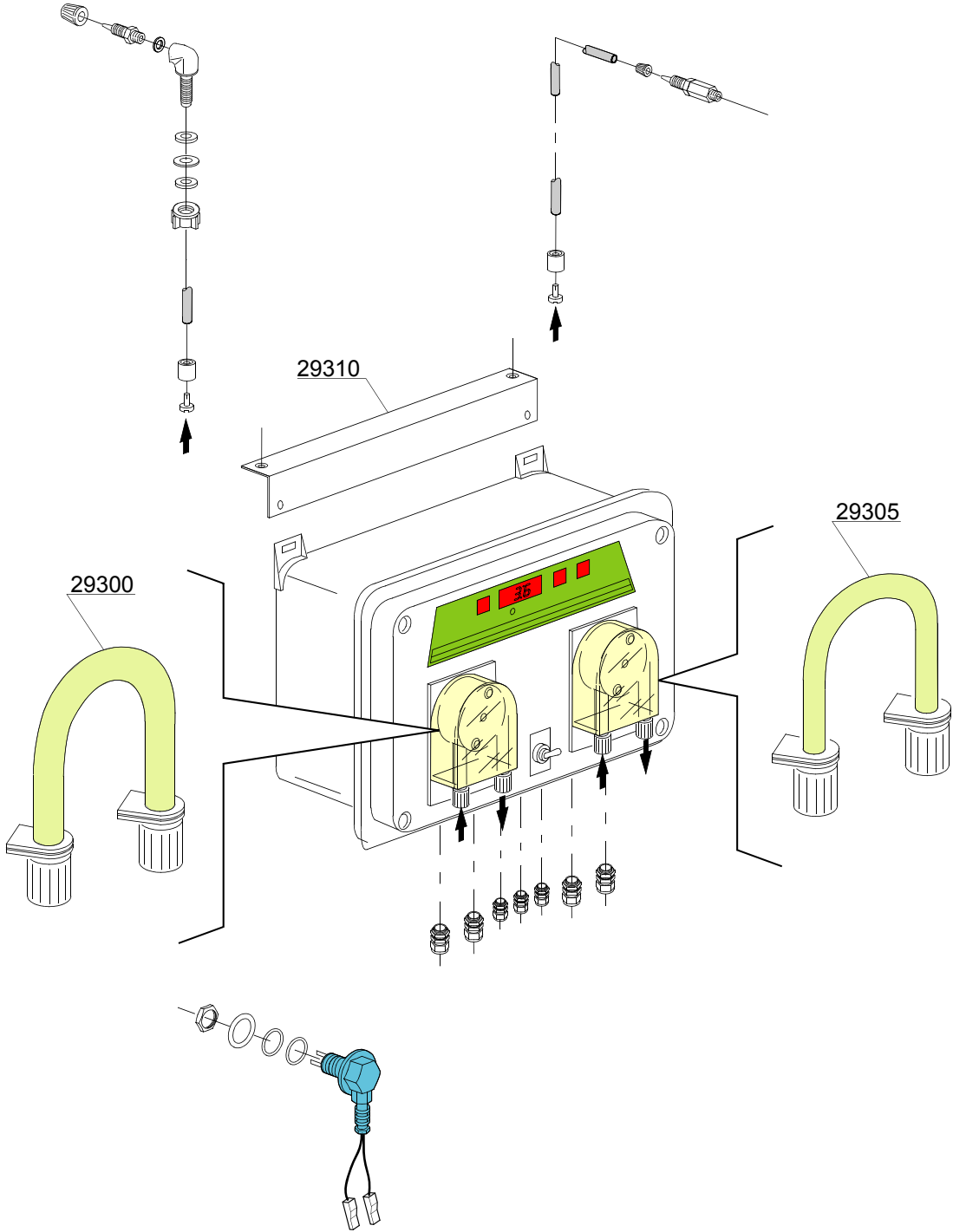

39_001_e

Spare parts

ID	P-code	SN from	SN to	Mod.	Acces.	Volt	Description
Module:Dispensers SDN-3							
	15181/A		-		sdn3		Dispensers assembly SDN-3
29300	15185		-		sdn3		Pipe fitting for detergent dispenser
29305	15186		-		sdn3		Pipe fitting for rinse dispenser
29310	3009669		-		sdn3		Dispensers assembly SDN-3 support

em=ELECTROMECHANICAL SWITCHES, uw=LOWER AND UPPER WASHER

39=39

sc9=STEAM CONDENSER - LC 91, csa=CONVEYOR SPEED ADJUSTING - LC 101, 972=90°MOTORIZED CHAIN CONVEYOR - LC 97/2, 973=180°MOTORIZED CHAIN CONVEYOR - LC 97/3, cw=ADDITIONAL BOILER FOR COLD WATER SUPPLY, dvgw=DVGW VALVE SYSTEM, des=DETERGENT ECONOMIZER SYSTEM, ti=TANK INSULATION, ds=DOUBLE SKIN, bp=BOOSTER PUMP, sdn3=DISPENSER SYSTEM SDN-3

A=3/N/PE~380-400V 50-60Hz, D=3/PE~200-210V 50-60Hz, F=2/PE~220-240V 50-60Hz, G=3/N/PE~415V 50-60Hz, H=3/PE~220-230V 50-60Hz, K=3/PE~380-400V 50-60Hz, L=3/PE~415V 50-60Hz, M=3/PE~440V 60Hz, P=1/N/PE~220-230V 50-60Hz, R=2/PE~220-240V 50-60Hz, U=1/N/PE~240V 50-60Hz, V=3/PE~240V 50-60Hz, W=1/N/PE~100-110V 50-60Hz

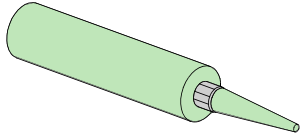
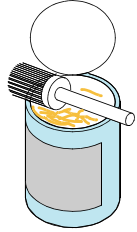
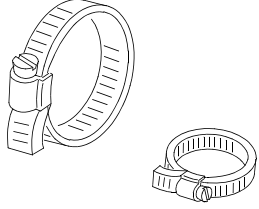
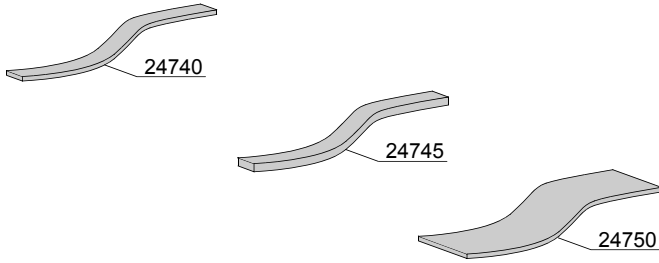
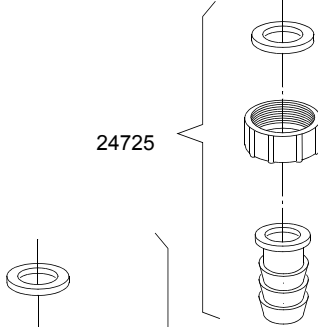
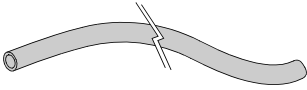
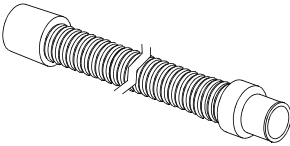
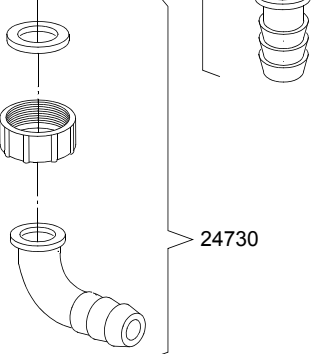
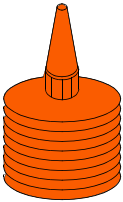
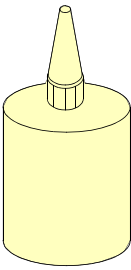
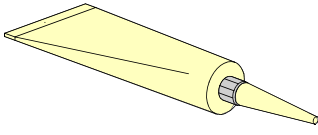
 <p>24700</p>	 <p>24705</p>	 <p>24760</p>
		 <p>24725</p>
 <p>24755</p>	 <p>24735</p>	 <p>24730</p>
 <p>24765</p>	 <p>24770</p>	 <p>24775</p>

Spare parts

ID	P-code	SN from	SN to	Mod.	Acces.	Volt	Description
Module:Accessory							
24700	---		-				Silicone UNI 9610 - UNI 9611
24705	---		-				Grease for high temperatures CCIAA 629224
24705	---		-				Grease for food - Loctite 8104 Cat. N° 26560
24725	15613/A		-				Fitting exauster
24730	15613		-				1" 1/4x30 nylon elbow
24735	10727		-				Exauster pipe Ø 24mm
24735	10200112		-				Exauster pipe Ø 32mm
24740	15750		-				20x2 self-stick mousse
24745	15751		-				20x4 self-stick mousse
24750	15752		-				60x2 self-stick mousse
24755	2907350		-				Flexible pipe EPDM Ø12
24755	2907352		-				Flexible pipe EPDM Ø12 - WRAS
24755	2907353		-				Flexible pipe EPDM Ø12
24760	11807		-				Steel hose clamp 15/24
24760	11806		-				Steel hose clamp 25/40
24760	11810		-				Steel hose clamp 40/60
24760	11824		-				Steel hose clamp 50/70
24760	2902491		-				Steel hose clamp 60/80
24765	---		-				-50°C +150°C threads dope
24770	---		-				Loctite 542 Cat.N° 54246 - DIN-DVGW 86.02 e 125
24770	---		-				Loctite 243 Cat.N° 18937 - 19386
24775	---		-				Loctite 511 Cat.N° 24003 - DIN-DVGW 86.01 e 125
24775	---		-				Loctite 577 Cat.N° 25392

em=ELECTROMECHANICAL SWITCHES, uw=LOWER AND UPPER WASHER

39=39

sc9=STEAM CONDENSER - LC 91, csa=CONVEYOR SPEED ADJUSTING - LC 101, 972=90°MOTORIZED CHAIN CONVEYOR - LC 97/2, 973=180°MOTORIZED CHAIN CONVEYOR - LC 97/3, cw=ADDITIONAL BOILER FOR COLD WATER SUPPLY, dvgw=DVGW VALVE SYSTEM, des=DETERGENT ECONOMIZER SYSTEM, ti=TANK INSULATION, ds=DOUBLE SKIN, bp=BOOSTER PUMP, sdn3=DISPENSER SYSTEM SDN-3

A=3/N/PE~380-400V 50-60Hz, D=3/PE~200-210V 50-60Hz, F=2/PE~220-240V 50-60Hz, G=3/N/PE~415V 50-60Hz, H=3/PE~220-230V 50-60Hz, K=3/PE~380-400V 50-60Hz, L=3/PE~415V 50-60Hz, M=3/PE~440V 60Hz, P=1/N/PE~220-230V 50-60Hz, R=2/PE~220-240V 50-60Hz, U=1/N/PE~240V 50-60Hz, V=3/PE~240V 50-60Hz, W=1/N/PE~100-110V 50-60Hz