

Shell assembly + Hydraulic circuit Mod. DSS42 A/W

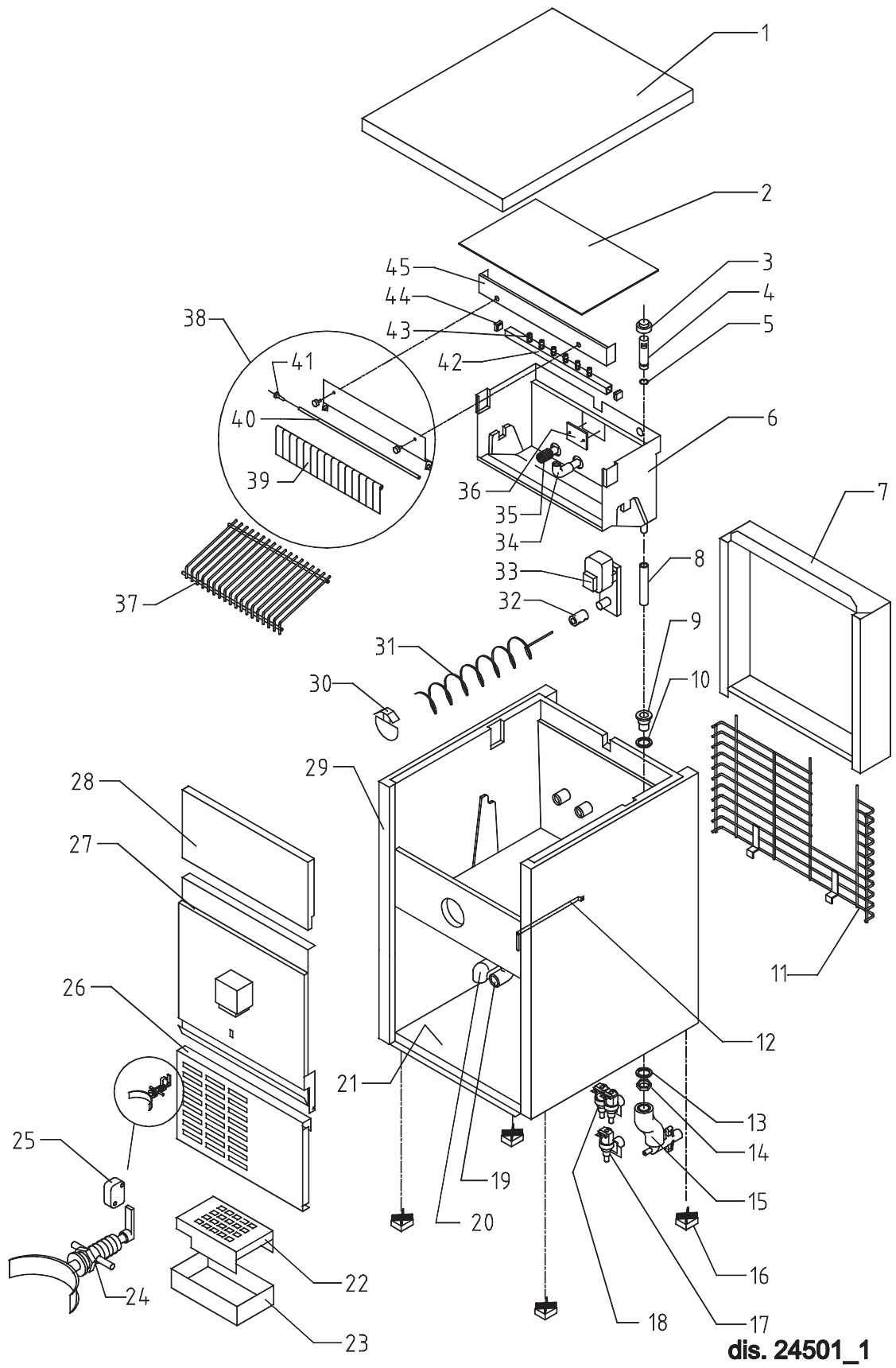

dis. 24501_1

Shell assembly + Hydraulic circuit Mod. DSS42 A/W (TAB. 38)

Ref.	Description	Refrigerant	A/W	Tension	Code
1	Top assembly				C22342
2	Evaporator cover				10023
3	Overflow cap				10305
4	Overflow tube				10133
5	Or gasket for overflow pipe				20233
6	Inner basin				10253
7	Back panel assembly				C22346
8	Overflow pipe				13108
9	Plastic nipple water outlet				10007
10	Silicone gasket				13006
11	Back grid				D12047
12	Bulb thermostat tube				20522
13	Semirigid polyethylene gasket				13007
14	Bin discharge nut				10096
15	Discharges manifold		A		C10006
15	Discharges manifold		W		C26452
16	Plug foot				10025
17	Inlet watervalue 1 way		A	1-2	23001
17	Inlet watervalue 1 way		A	3	23260
18	Inlet watervalue 2 ways		W	1-2	23010
18	Inlet watervalue 2 ways		W	3	23261
19	Pump suction pipe				13015
20	Pump delivery pipe				13016
21	Base plate				21013
22	Glass support				22350
23	Drip tray				22349
24	Push ice dispenser assembly				C26544
25	Microswitch				23055
26	Front grid panel				22343
27	Panel with distributor				D22338
28	Front-upper panel assembly				C22347B
29	Foamed cabinet assy				C11051
30	Cubes holding plate				22402
31	Out way ice cubes screw /ice cubes transport screw				20281
32	Screw connection bush for ice cubes transport				20280
33	Gearmotor			1-2	23310
33	Gearmotor			3	23614
34	Sprayers feeding pipe				13005
35	Pump suction filter				20005
36	Slide keep plate				10009
37	Ice cubes slide				D12038
38	Flags support assy				C22035
39	Flag				10005
40	Flags rod				12007
41	Flags rod clip				10010
42	Sprayers bar assembly				C20189
43	Sprayer				D20002
44	Sprayers bar plug				10012
45	Evaporator holder				22229

Note: 3. Code 10305 from number 64086.
4. Code 13030 until number 64085. Code 10133 from number 64086.
5. Code 20233 from number 64086.
8. Code 13030 until number 64085. Code 13108 from number 64086.
12. Code 20017 until number 95200. Code 20522 from number 95201.

Cooling system assembly Mod. DSS42 A/W

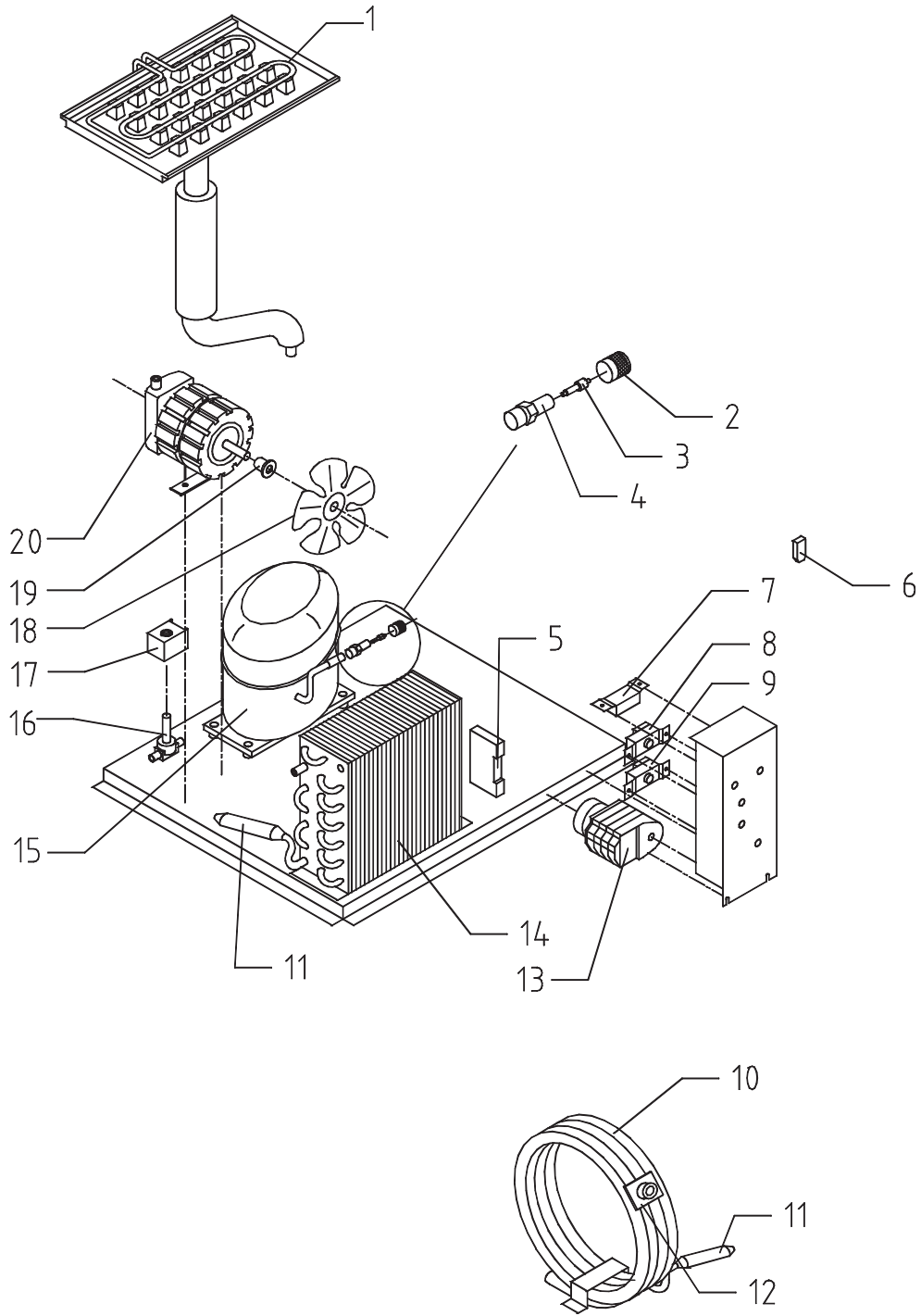

dis. 24502_0

Cooling system assembly Mod. DSS42 A/W (TAB. 39)

Ref.	Description	Refrigerant	A/W	Tension	Code
1	Evaporator				D10113
2	Vacuum-charge valve plug				14006
3	Vacuum-charge valve device				14005
4	Vacuum- charge valve body				14007
5	Electronic timer				23560
6	Anti radio interference filter		W	1	23457
7	Condenser pressure switch		W		23175
8	Bin thermostat				23005
9	Evaporator thermostat				23591
10	Water condenser		W		14014
11	Molecular drier				14009
12	Safety thermostat		W		C23114
13	Timer			1-2	23247
13	Timer			3	23258
14	Air condenser		A		20019
15	Compressor	R404A		1	23437
15	Compressor	R404A		2	23495
15	Compressor	R404A		3	23464
15	Compressor	R22		1	23320
15	Compressor	R22		2	23344
16	Hot gas valve body				20410
17	Hot gas coil			1-2	23091
17	Hot gas coil			3	23256
18	Suction impeller				10213
19	Hub+washer+screw				10014
20	Pump			1-2	23002
20	Pump			3	23264