

CME1356R and CME1656R Service Parts

This parts list contains the part numbers and description of the replacement parts available for these two models.

They have been manufactured in both 50 and 60 Hz, plus there have been model series changes from A, to C and to D.

To avoid costly and time consuming errors, double check the model and voltage before ordering a part.

Table of Contents

| | |
|--------------------------------|---------|
| Cabinet | page 2 |
| Water System | page 3 |
| Refrigeration System | page 4 |
| Electrical | page 5 |
| ERC411 | page 6 |
| BH900 | page 7 |
| BH1356 | page 8 |
| Kit Parts | page 9 |
| Wiring Diagrams | page 10 |

CME1356R and CME1656R Service Parts

Cabinet

Note: Front panels changed from two 24" panels to one 48" panel (with top trim strip) in March 1999

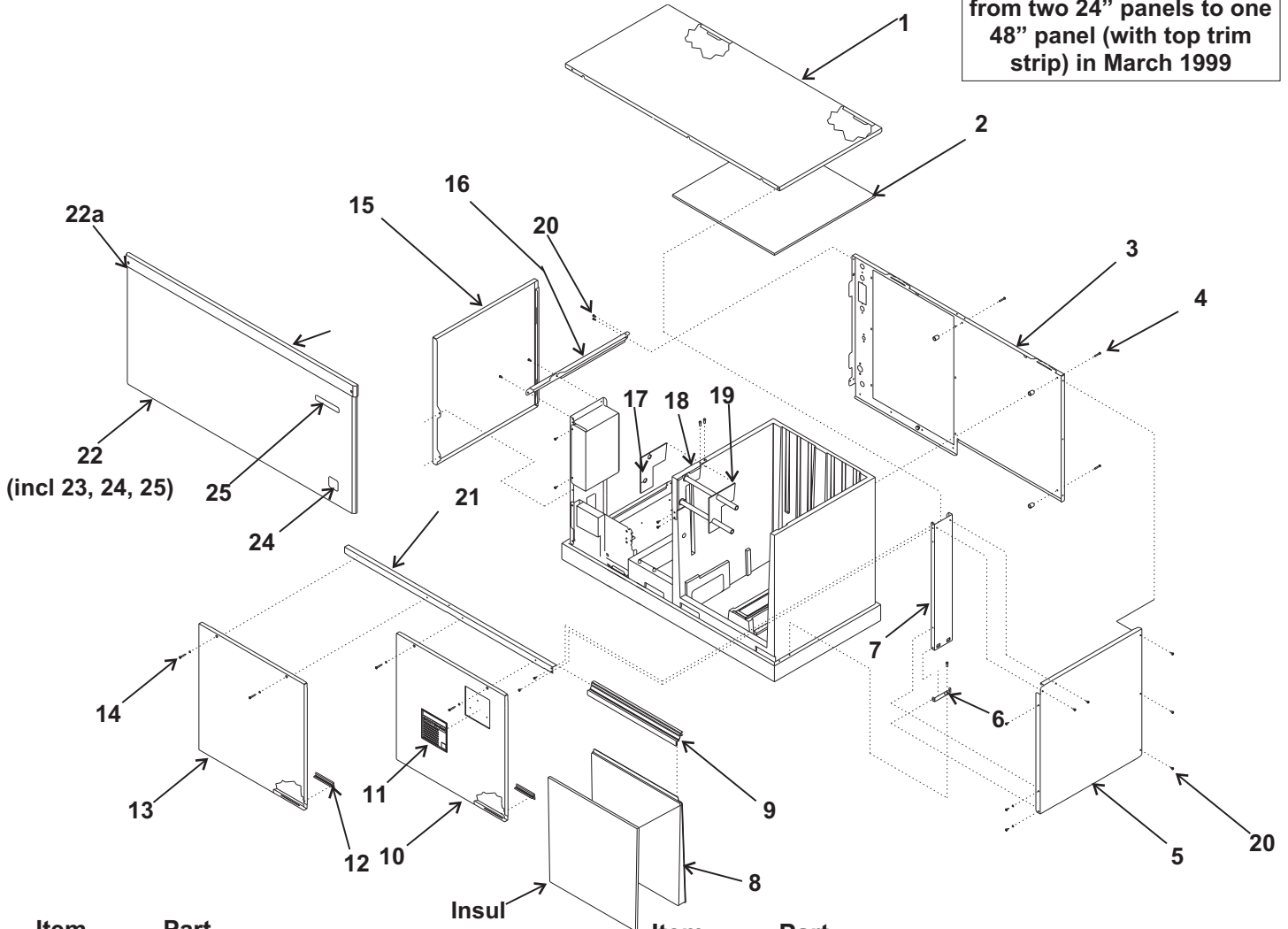

| Item Number | Part Number | Description | Item Number | Part Number | Description |
|-------------|-------------|---|-------------|-------------|------------------------|
| 1 | A37202-015 | Top panel, Grey | 13 | A37201-015 | Left front panel, grey |
| | A37202-002 | Top panel, SS | | A37201-002 | Left front panel, SS |
| | 02-3823-21 | Top panel, plastic for C thru H series. Will not fit A or B series. | 14 | 03-1728-01 | Front panel screw |
| 2 | 02-3686-01 | Insulation | 15 | A37198-015 | Left side panel, grey |
| 3 | A37197-001 | Back panel for A or B series | 16 | A37198-002 | Left side panel, SS |
| | A37671-001 | Back panel for C thru H series | 17 | A37193-001 | Left side channel |
| 4 | 03-1404-37 | Screw | 18 | 02-3696-03 | Left grommet |
| 5 | A37199-015 | Rt side panel, grey, A or B | 19 | A37216-001 | Bracket |
| | A37199-002 | Rt side panel, SS, A or B | 20 | 02-3696-02 | Right grommet |
| | A37668-001 | Rt side panel, C thru H series | 21 | 03-1531-01 | Screw |
| 6 | A37194-001 | Right bottom channel | 22 | A37195-001 | Channel, front top |
| 7 | A37213-001 | Right side support | 22a | A37489-001 | SS 48" panel |
| 8 | 02-3702-21 | Evaporator cover, w/ insul | 23 | A37489-002 | Grey 48" panel |
| 9 | 02-3701-01 | Cover retainer | 24 | 03-1735-01 | Screw |
| 10 | A37200-015 | Right front panel, grey | 25 | 02-3794-02 | Trim strip |
| | A37200-002 | Right front panel, SS | | 03-1731-02 | Push nut |
| 11 | 15-0808-01 | Emblem | | 15-0792-01 | CM ³ emblem |
| 12 | 02-3699-01 | Panel support clip | | 17-0711-02 | Scotsman Emblem |
| | | | | 03-0271-00 | Speed nut for emblems |
| | | | | | #24 & 25 |

CME1356R and CME1656R Service Parts

Water System

| Item Number | Part Number | Description |
|-------------|-------------|-------------|
|-------------|-------------|-------------|

| | | |
|----|------------|--------------------------|
| 1 | 02-3613-01 | Elbow |
| 2 | 02-3520-01 | Elbow, rt. 1356 |
| 3 | 13-0617-48 | O-ring |
| 4 | 02-3518-01 | Manifold |
| 5 | 02-3519-01 | Manifold right, 1656 |
| 6 | 13-0840-01 | Plug |
| 7 | 02-2527-01 | Water distributor |
| 8 | A37315-021 | Evaporator |
| 9 | 02-3725-01 | Hose clamp |
| 10 | 02-3672-01 | Right trough, 1656 only |
| 11 | 02-3672-02 | Left trough |
| 12 | A37337-001 | Evap support |
| 13 | 11-0540-21 | Ice sensor (set) |
| 14 | 02-3337-02 | Ice deflector |
| 15 | 02-3706-01 | Upper inner splash panel |

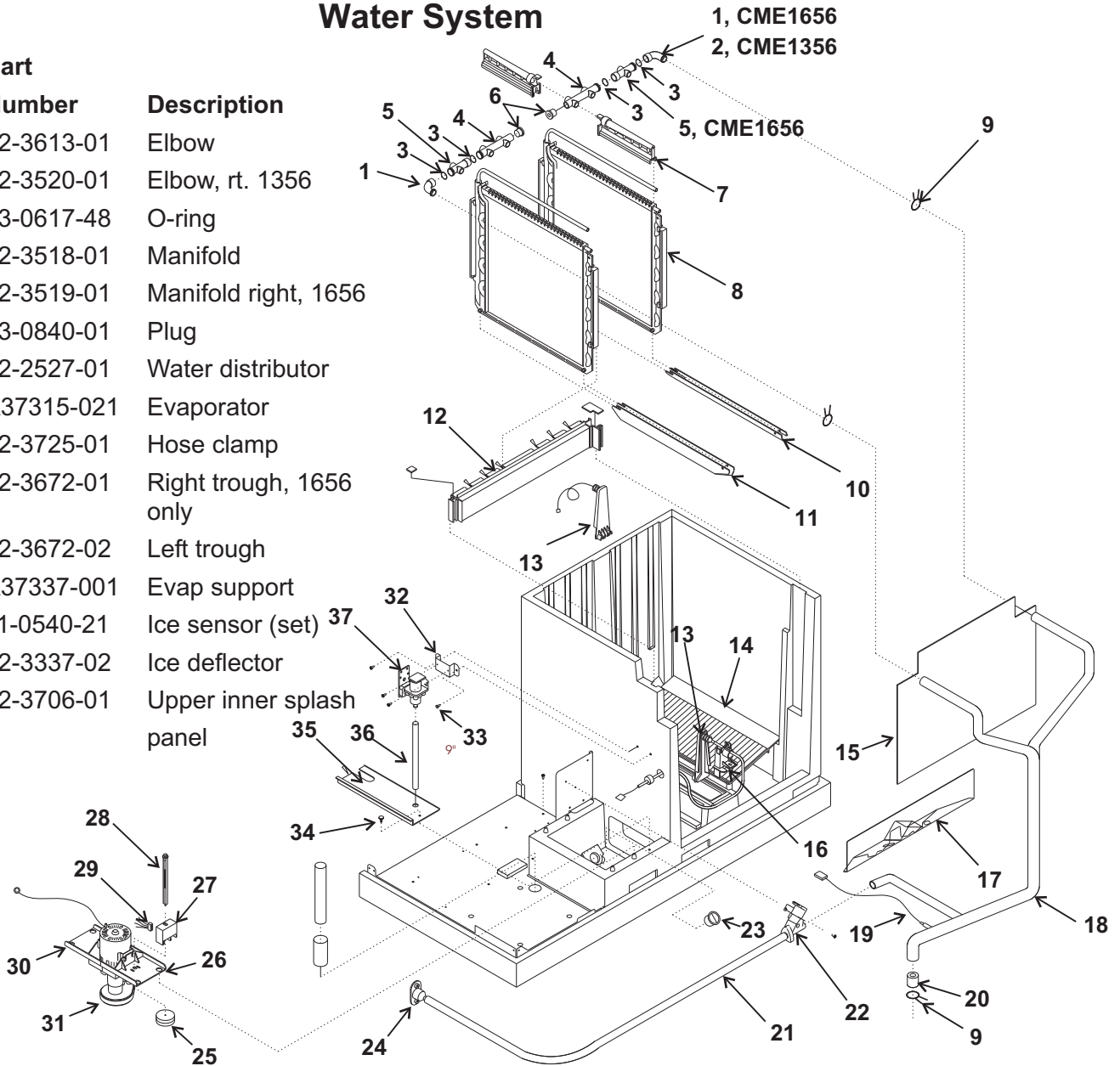

| | | | | | |
|----|------------|---|----|------------|----------------------------|
| 16 | 02-3689-01 | Ice sensor holder | 27 | 11-0539-51 | Water level sensor |
| 17 | 02-3680-01 | Lower inner splash panel | 28 | 02-3383-04 | Float stem, tan for 1356 |
| 18 | 02-3660-02 | CME1356 water hose | | 02-3383-05 | Float stem, brown for 1656 |
| | 02-3660-01 | CME1656 water hose | 29 | 12-2665-01 | Harness for water sensor |
| 19 | 11-0515-01 | Temp sensor set | 30 | 02-3388-05 | Pump bracket |
| 20 | 02-3614-01 | Flow restrictor, 1356 only. No longer used. | 31 | 12-2582-21 | Water pump |
| 21 | 13-0674-06 | Drain hose, order 2 units | 32 | A37204-001 | Bracket |
| 22 | 11-0514-01 | Purge valve | 33 | 03-1404-18 | Screw |
| | 11-0514-21 | Coil only | 34 | 03-1691-01 | Nylon screw |
| 23 | 02-3703-01 | Drain plug | 35 | 02-3534-01 | Reservoir cover |
| 24 | 02-3692-21 | Drain fitting | 36 | 13-0674-02 | Tube, order 1 unit |
| 25 | 02-3341-01 | Float | 37 | 12-2666-01 | Water solenoid valve |
| 26 | 02-3388-04 | Pump bracket | | 16-0355-00 | Coupling half |

CME1356R and CME1656R Service Parts

Refrigeration

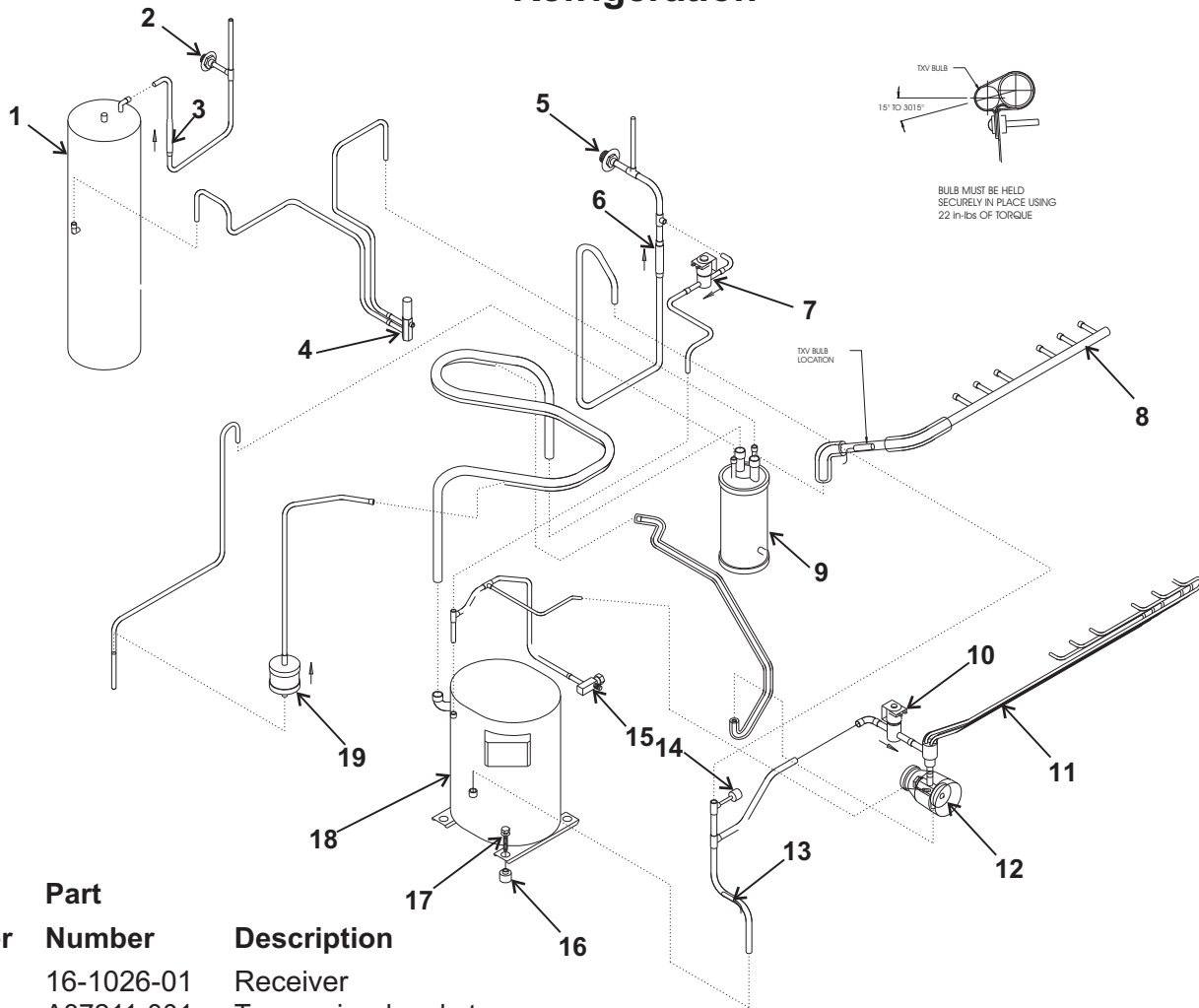

| Item Number | Part Number | Description |
|-------------|---|---------------------------------|
| 1 | 16-1026-01 | Receiver |
| | A37211-001 | Top receiver bracket |
| | A37212-001 | Bottom receiver bracket |
| 2 | 16-0850-03 | Liquid line fitting |
| 3 | 16-1029-01 | Liquid line check valve |
| 4 | 16-1030-01 | Liquid line access valve |
| 5 | 16-0850-01 | Discharge line fitting |
| 6 | 16-1028-01 | Discharge check valve |
| 7 | 11-0513-21 | Harvest bypass valve |
| 7a | 16-1063-01 | Strainer for bypass valve |
| 8 | 16-1032-02 | Suction manifold, 1656 |
| | 16-1032-01 | Suction manifold, 1356 |
| 9 | 16-0801-22 | Accumulator w/insul. |
| | A37210-001 | Accumulator support |
| 10 | 11-0507-01 | Hot gas valve, 1356 |
| | 11-0507-02 | Hot gas valve, 1656 |
| | 12-2719-23 | Coil for hot gas valve |
| | 16-1063-03 | Strainer for bypass valve |
| 11 | A37312-021 | Distributor and tubes, 1356 |
| | A37312-022 | Distributor and tubes, 1656 |
| 12 | 16-1066-21 | TXV, ANE1 ¼ SZ |
| | 02-3396-01 | Insulation for TXV |
| 13 | 11-0515-01 | Temp sensor set |
| 14 | 11-0501-22 | Hi pressure cut out |
| 15 | 16-0832-20 | Suction access valve |
| | 16-0832-03 | Port cap |
| | 16-0832-02 | Stem cap |
| 16 | 18-2300-27 | Grommet |
| | 18-2200-27 | Sleeve |
| 17 | 03-1405-20 | Bolt |
| | 03-1407-07 | Washer |
| 18 | 18-8751-23 | Compressor, 60 Hz, single phase |
| | 18-8751-25 | Compressor, 60 Hz, 3 phase |
| | 18-8751-27 | Compressor, 50 Hz, single phase |
| | Replacement compressors include a crankcase heater (pn 18-2308-01) and a dryer. | |
| 19 | 02-3319-02 | Dryer |

CME1356R and CME1656R Service Parts

Electrical

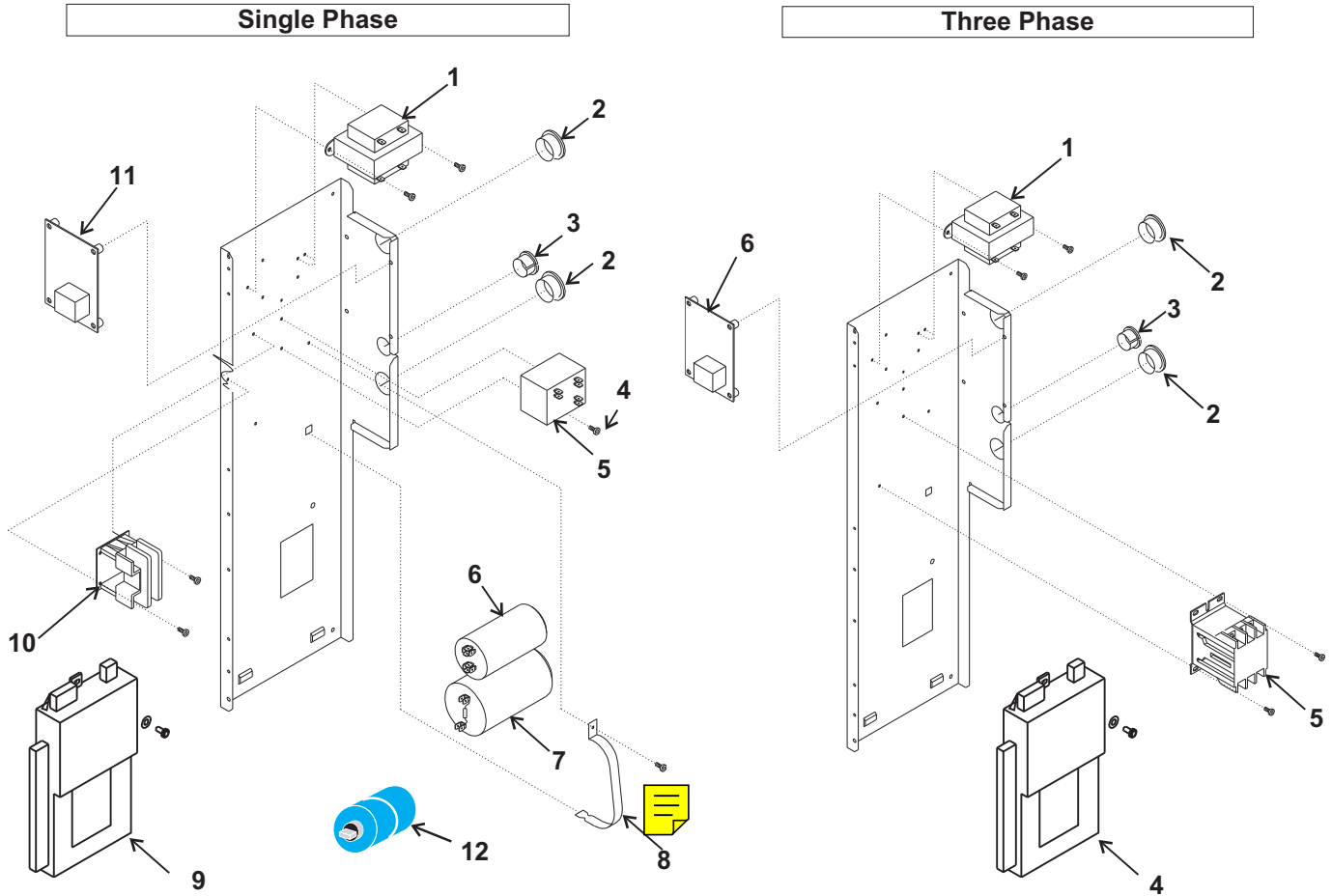

Single Phase

| Item Number | Part Number | Description |
|-------------|-------------|------------------------|
| 1 | A37217-001 | Transformer |
| 2 | 12-1213-11 | Snap bushing |
| 3 | 12-1213-10 | Snap bushing |
| 4 | 03-1531-01 | Screw |
| 5 | 18-1903-46 | 60 Hz potential relay |
| | 18-1903-56 | 50 Hz potential relay |
| 6 | 18-1902-56 | Run capacitor |
| 7 | 18-1901-27 | 60 Hz start capacitor |
| | 18-1901-57 | 50 Hz start capacitor |
| 8 | A37125-001 | Strap |
| 9 | 12-2838-23 | Controller |
| 10 | 12-2469-01 | Single phase contactor |
| 11 | 11-0531-22 | Purge valve timer kit |
| 12 | 18-8840-01 | PTCR |
| 12a | 18-8840-02 | Bracket for PTCR |

Three Phase

| Item Number | Part Number | Description |
|-------------|-------------|-----------------------|
| 1 | A37217-001 | Transformer |
| 2 | 12-1213-11 | Snap bushing |
| 3 | 12-1213-10 | Snap bushing |
| 4 | 12-2838-23 | Controller |
| 5 | 12-2533-01 | Three phase contactor |
| 6 | 11-0531-22 | Purge valve timer kit |

| Item Number | Part Number | Description |
|------------------|-------------------------|----------------------------------|
| Not Shown | 11-0521-21 | Bin thermostat |
| | 02-3740-01 | Thermostat bracket |
| | 03-1675-03 | 3 pronged knob |
| | 12-2701-01 | Bin thermo harness |
| | 12-2663-02 | Lo voltage harness A-C |
| | 12-2660-01 | Hi voltage harness A-C |
| | 12-2791-02 | Low voltage harness, D - H |
| | 12-2797-01 | Hi voltage harness, D - H |
| | 12-2679-01 | Relay, -6B, -6C, or -6D -H |
| | 12-2686-01 | Fuse, -6B, -6C or -6D-H |
| | 12-2639-02 | Transformer, -6B, thru -6D -H |
| | 12-2798-01 | Hi volt harness, -6B thru -6D -H |
| | 12-2738-02 | Lo volt harness, -6B & -6C |
| 12-2792-02 | Lo volt harness, -6D -H | |

CME1356R and CME1656R Service Parts

ERC411 Remote Condenser

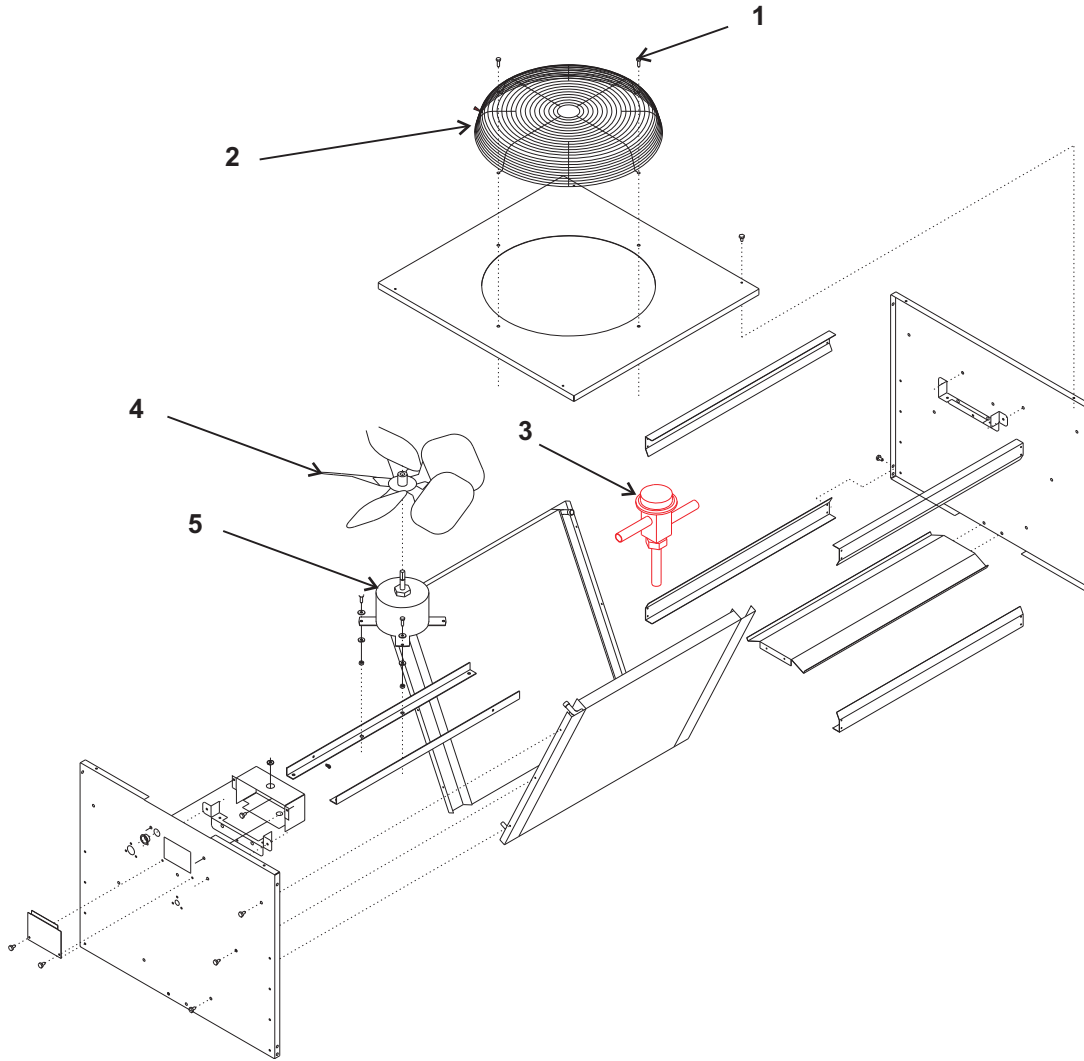

| Item Number | Part Number | Description |
|-------------|-------------|-------------|
| 1 | 03-1405-08 | Screw |
| 2 | 02-3575-01 | Fan guard |
| 3 | 16-1025-01 | Headmaster |
| 4 | 18-8816-01 | Fan blade |
| 5 | 12-2651-01 | Fan motor |

Not Shown:

| | |
|------------|--------------------------|
| A37169-001 | Leg |
| A37170-001 | Leg brace |
| 03-1645-01 | Screw for legs |
| 16-0850-01 | Quick connect, discharge |
| 16-0850-03 | Quick connect, liquid |

CME1356R and CME1656R Service Parts

BH900 Ice Storage Bin

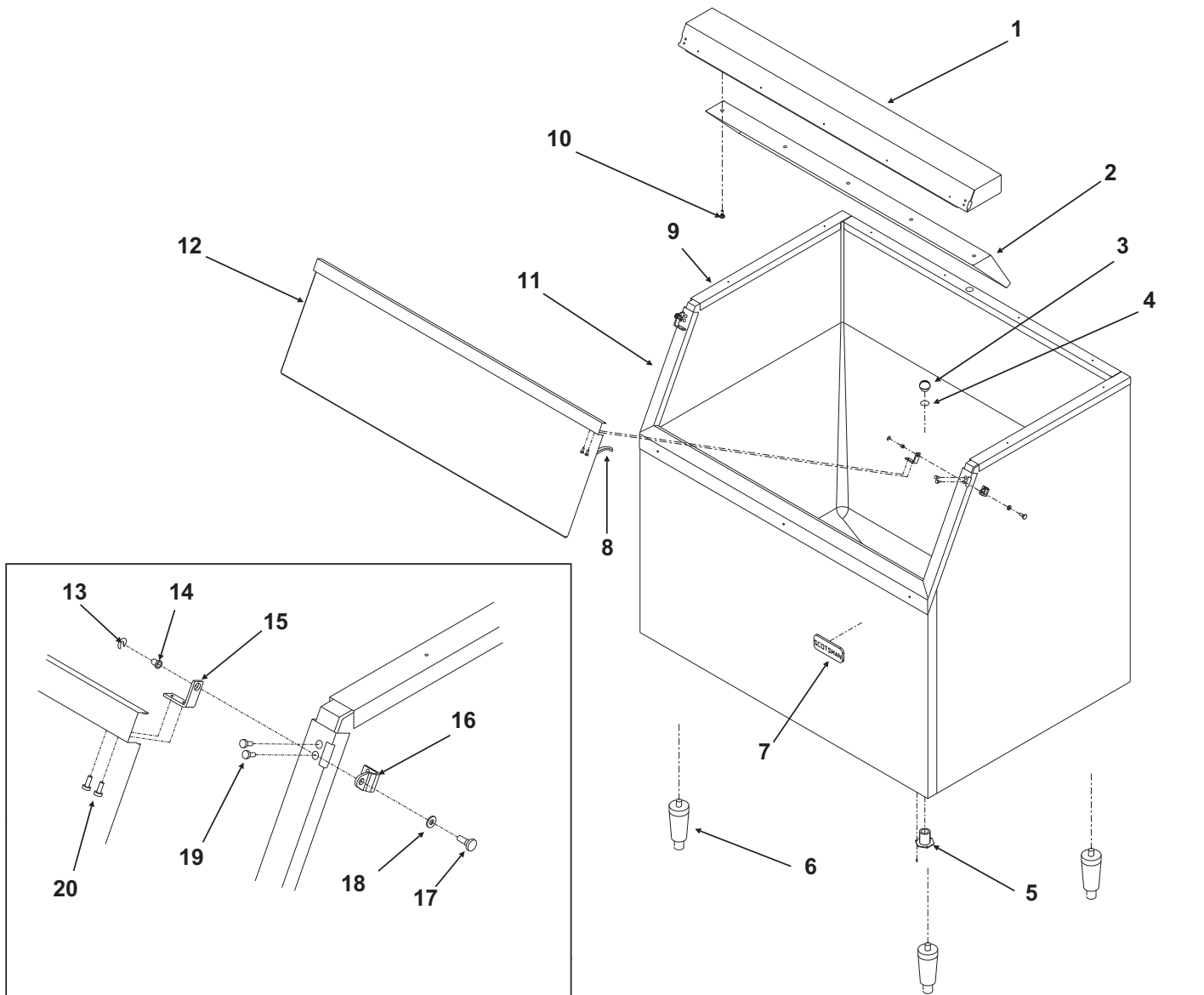

| ITEM NUMBER | PARTS NUMBER | DESCRIPTION |
|-------------|----------------------|----------------------------|
| 1 | A35322-020 | Canopy Assembly |
| 2 | A35152-001 | Ice Baffle |
| 3 | 02-2809-01 | Drain Top |
| 4 | 13-0617-11 | O-ring |
| 5 | 02-3201-01 | Drain casting |
| 6 | KLP2E Leg Kit, Black | |
| 7 | 15-0808-01 | Emblem |
| 8 | 13-0595-00 | Door gasket(order qty 7) |
| 9 | 19-0503-04 | Bin gasket (order by foot) |
| 10 | 03-0727-11 | Baffle screw |
| 11 | A35275-001 | Door frame assy. except C |
| | A37641-021 | C series door frame |
| 12 | A35323-020 | Door with gasket - BH900 |
| 13 | 03-1539-09 | "E" ring |
| 14 | 02-2380-01 | Hinge bushing |
| 15 | 02-3195-01 | Door hinge |
| 16 | 02-3196-01 | Bin hinge |
| 17 | 02-2806-01 | Shoulder screw |
| 18 | 02-2380-02 | Spacer |
| 19 | 03-1403-29 | Screw 10-24 |
| 20 | 03-1403-24 | Screw 10-24 |

CME1356R and CME1656R Service Parts

BH1356 Ice Storage Bin

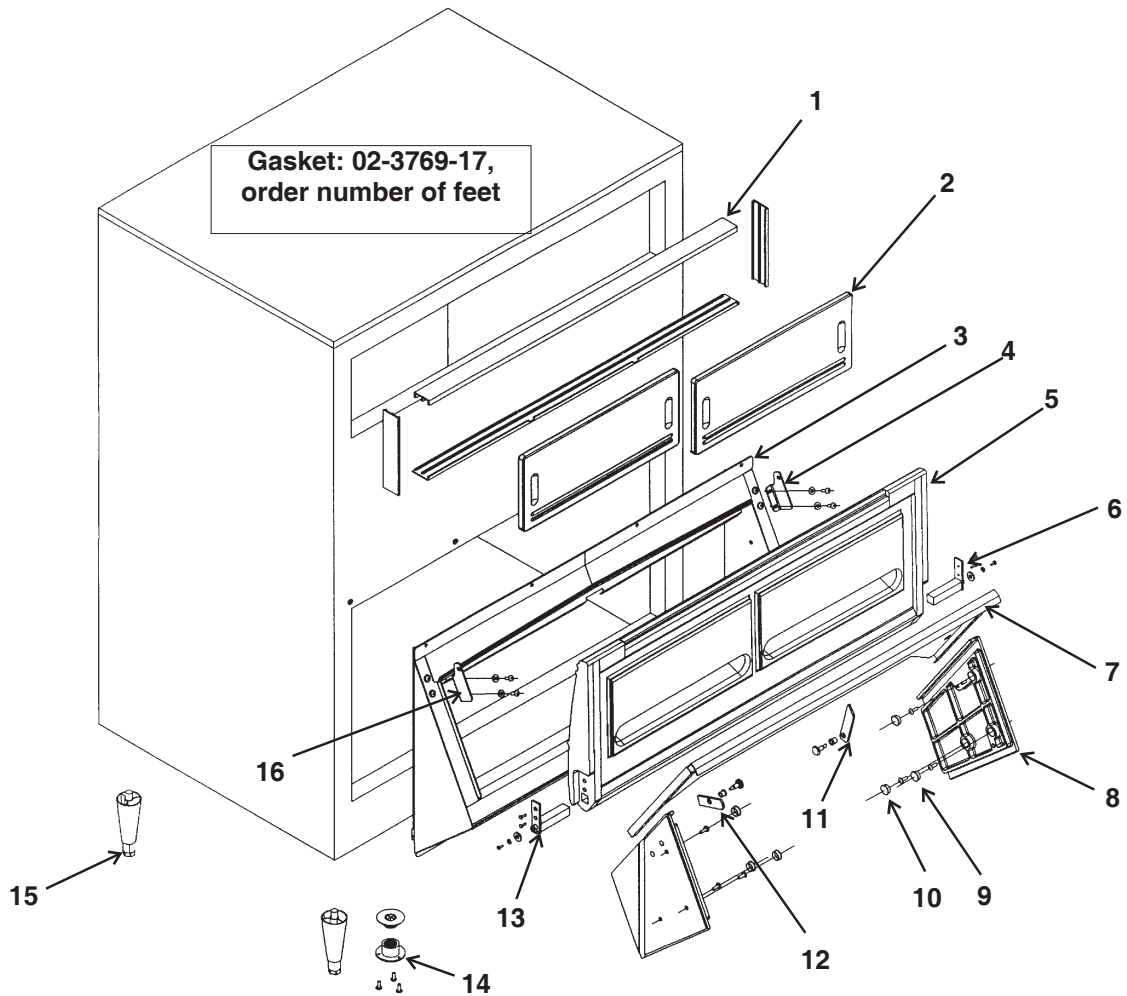

| Item Number | Part Number | Description |
|-------------|-------------|------------------------|
| 1 | 02-3769-02 | Track |
| 2 | 02-3769-16 | Window |
| 3 | 02-3769-04 | Lower frame assembly |
| 4 | 02-3769-08 | Left and right hinges |
| 5 | 02-3769-05 | Door with door hinges |
| 6 | 02-3769-07 | Right hinge |
| 7 | 02-3769-09 | Ice gate |
| 8 | 02-3769-12 | End plate guide (pair) |
| 9 | 02-3769-13 | Screws for end plate |
| 10 | 02-3769-14 | Plugs for end plate |
| 11 | 02-3769-10 | Catch for ice gate |
| 12 | 02-3769-15 | Ice gate retainer |
| 13 | 02-3769-06 | Left hinge |
| 14 | 02-3769-01 | Plastic drain |
| 15 | KLP2S | Legs |

CME1356R and CME1656R Service Parts Kit Parts

Stacking Kit - KSCME6-LG-B

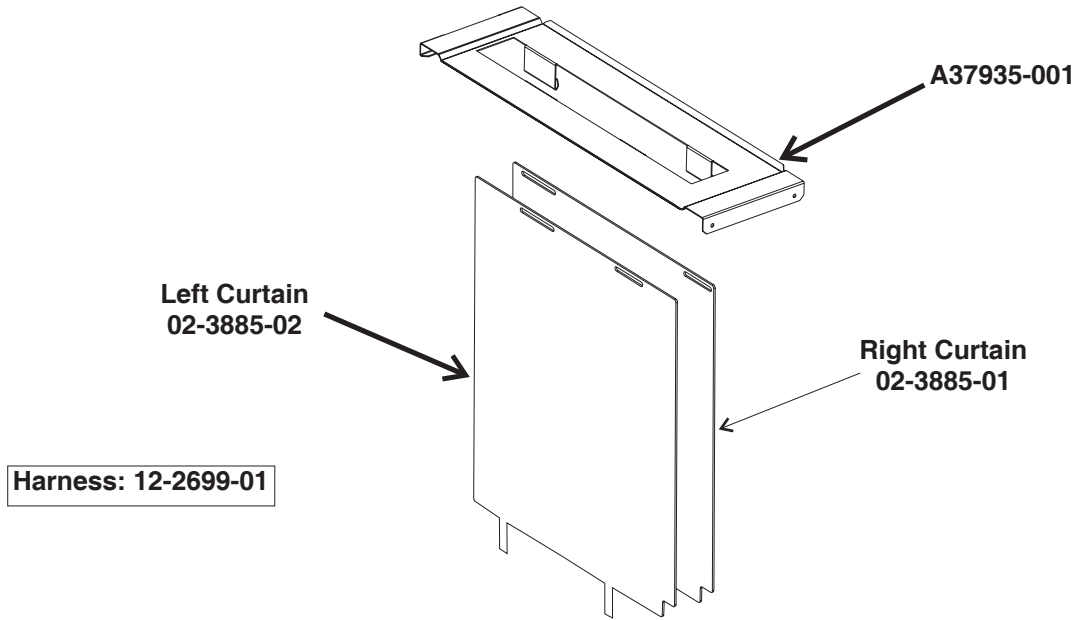

Stacking Kit - KSCME6-LG

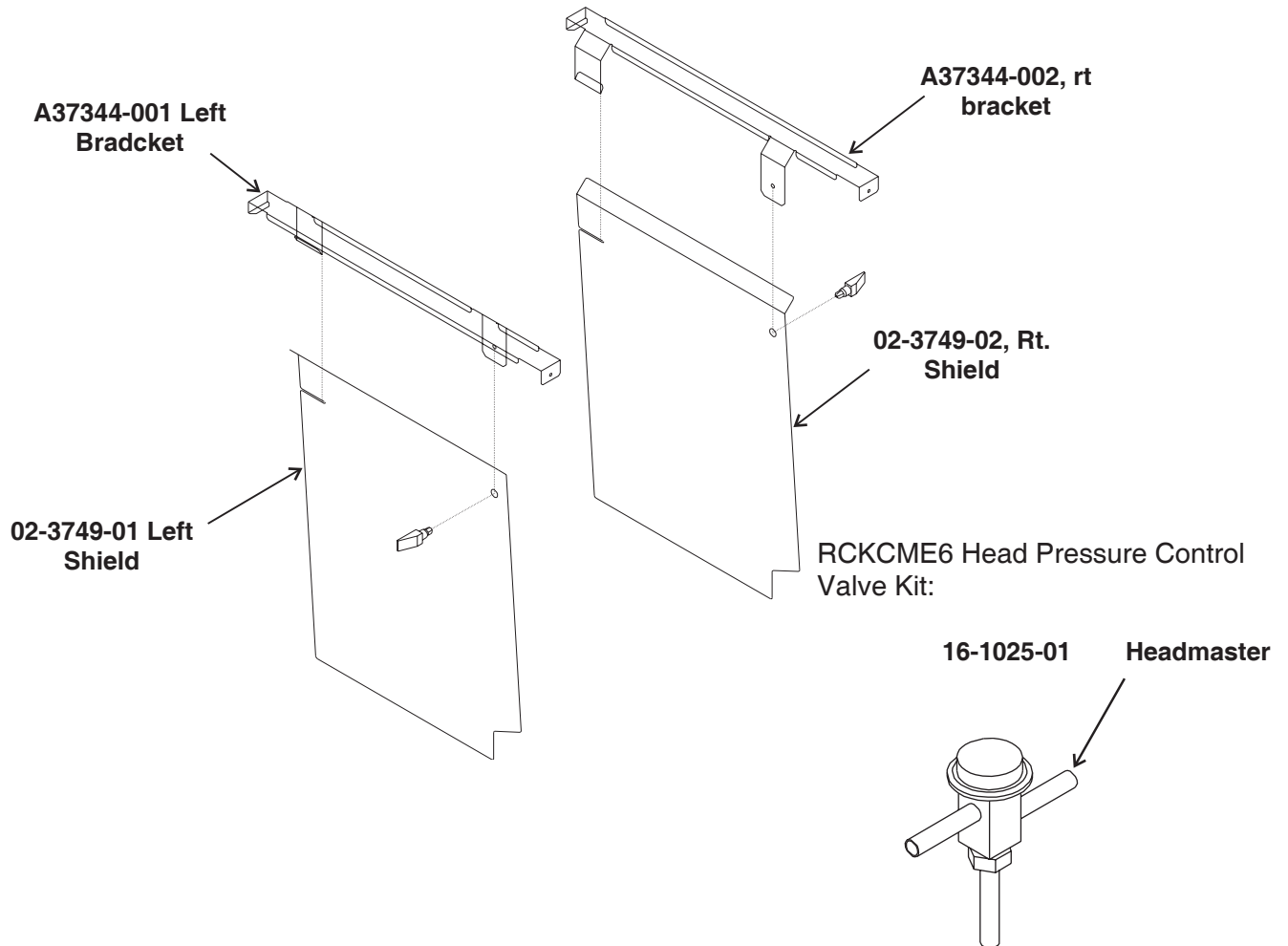

CME1356R and CME1656R Service Parts

Single Phase Wiring Diagram, D - H series

17-2772-01

Use Copper Conductors Only

- 1 DASHED LINES INDICATE FIELD WIRING WHICH MUST BE INSTALLED IN ACCORDANCE WITH THE NATIONAL ELECTRICAL CODE AND ALL STATE AND LOCAL CODES.
- 2 WIRE COLOR FOR 208-230/60/1 UNITS: BLACK
WIRE COLOR FOR 230/50/1 UNITS: BLUE
- 3 WIRE COLOR FOR 208-230/60/1 UNITS: BLACK W/WHITE STRIPE
WIRE COLOR FOR 230/50/1 UNITS: BROWN

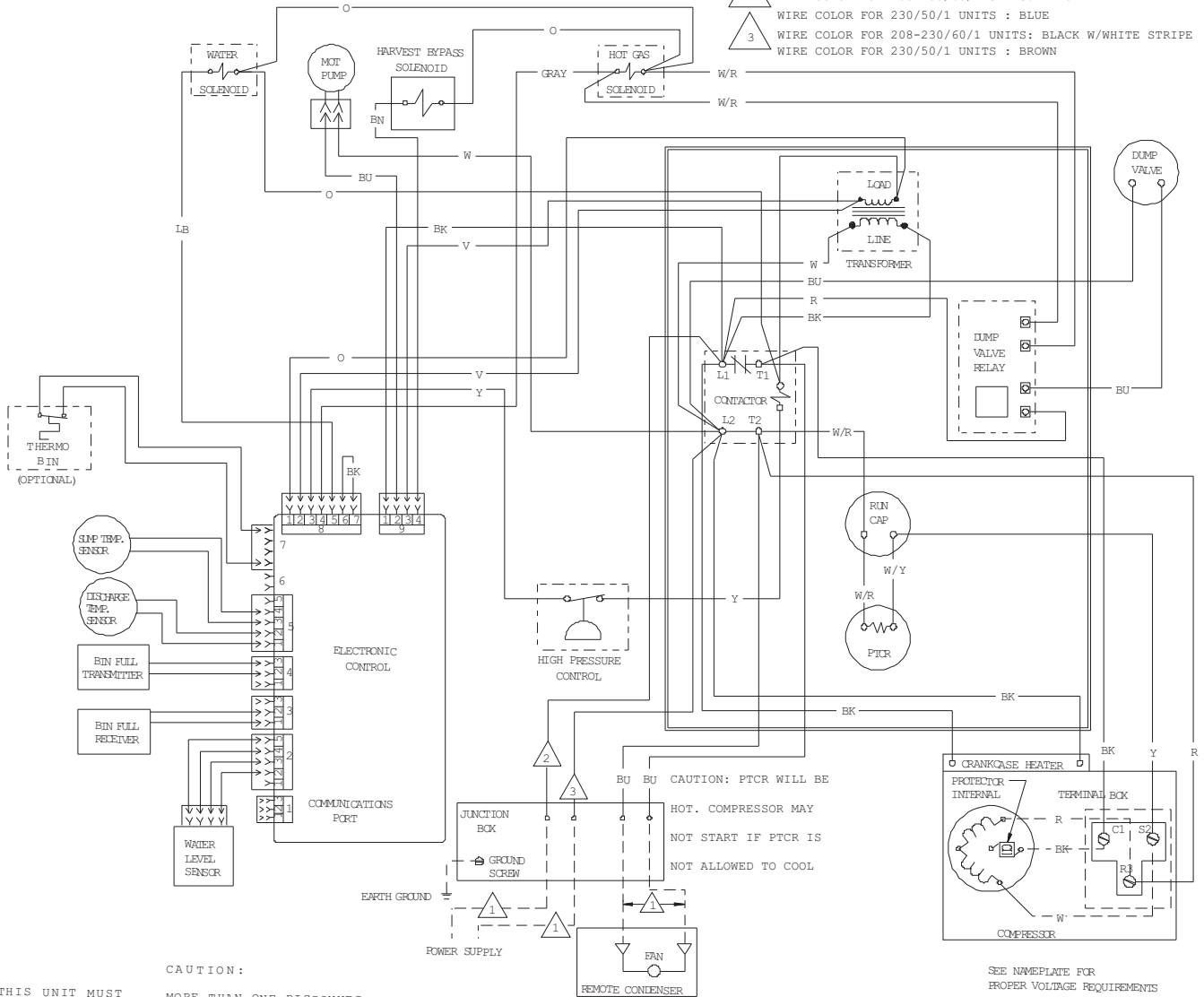

THIS UNIT MUST BE GROUNDED.

CAUTION: MORE THAN ONE DISCONNECT MEANS MAY BE REQUIRED TO DISCONNECT ALL POWER TO THIS UNIT.

SEE NAMEPLATE FOR PROPER VOLTAGE REQUIREMENTS AND MAXIMUM FUSE SIZE

CME1356R and CME1656R Service Parts

Single Phase Schematic Diagram, D - H Series

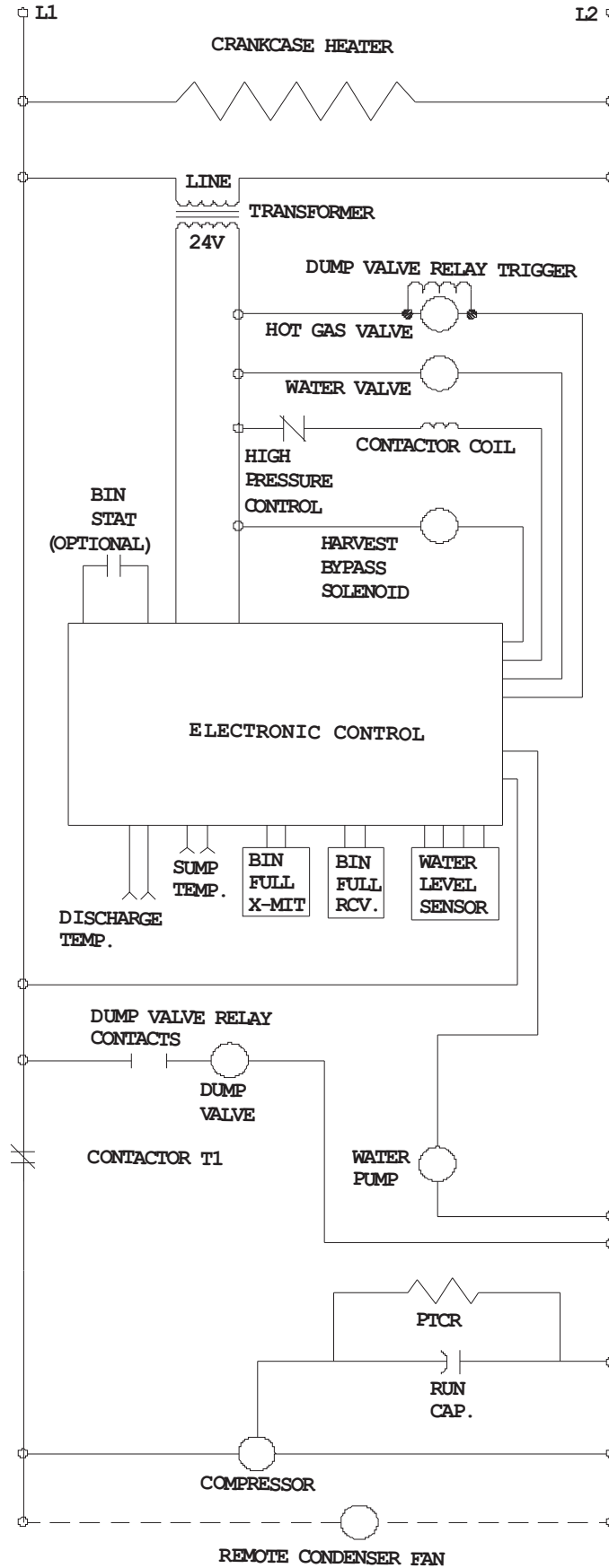

CME1356R and CME1656R Service Parts

Three Phase Wiring Diagram, D - H Series

17-2821-01

USE COPPER CONDUCTORS ONLY

▲ DASHED LINES INDICATE FIELD WIRING WHICH MUST BE INSTALLED IN ACCORDANCE WITH THE NATIONAL ELECTRICAL CODE AND ALL STATE AND LOCAL CODES

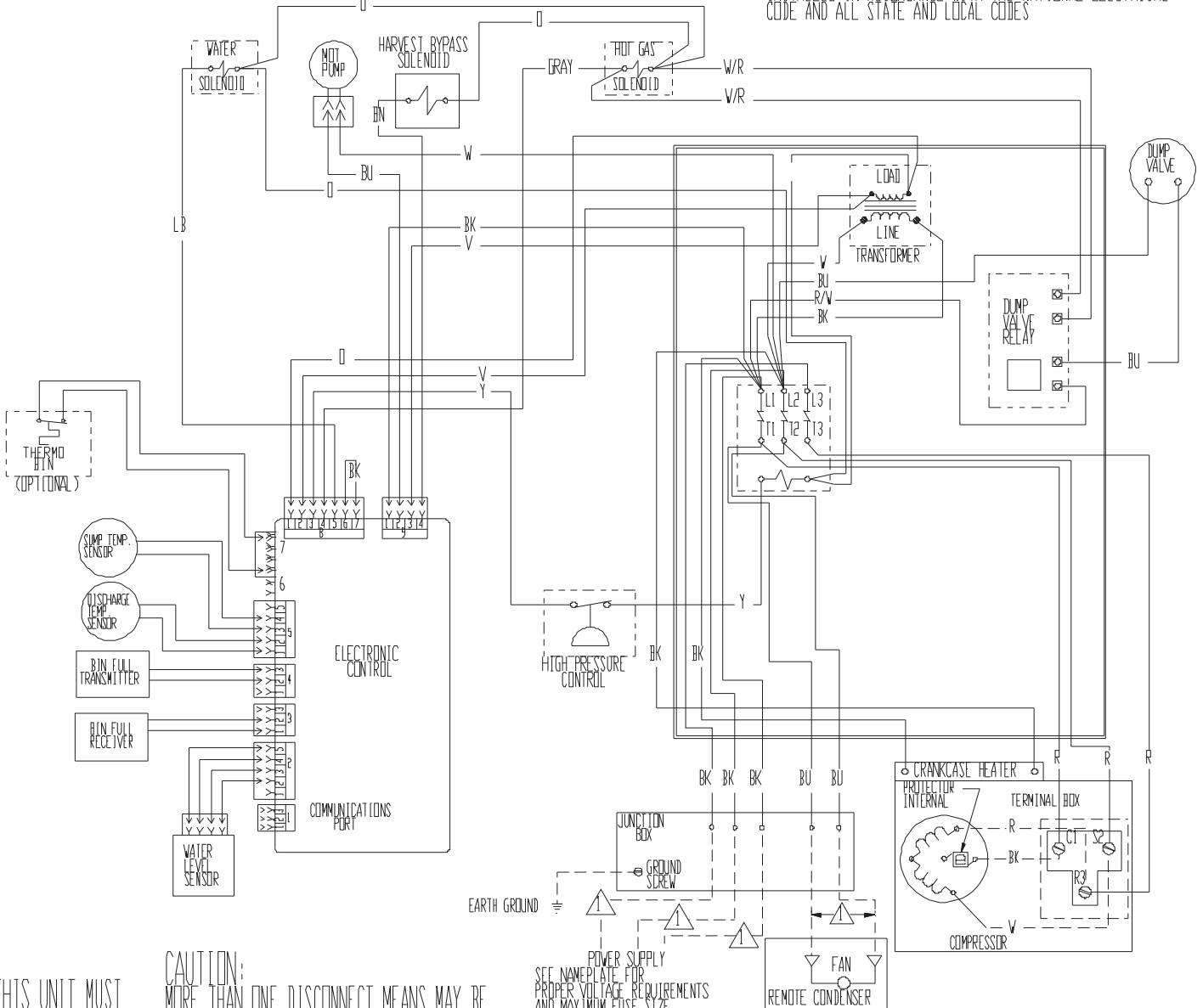

THIS UNIT MUST BE GROUNDED.

CAUTION: MORE THAN ONE DISCONNECT MEANS MAY BE REQUIRED TO DISCONNECT ALL POWER TO THIS UNIT.

SEE NAMEPLATE FOR PROPER VOLTAGE REQUIREMENTS AND MAXIMUM FUSE SIZE

CME1356R and CME1656R Service Parts

50 Hz Wiring Diagram, D - H Series

▲ DASHED LINES INDICATE FIELD WIRING WHICH MUST BE INSTALLED IN ACCORDANCE WITH THE NATIONAL ELECTRICAL CODE AND ALL STATE AND LOCAL CODES.

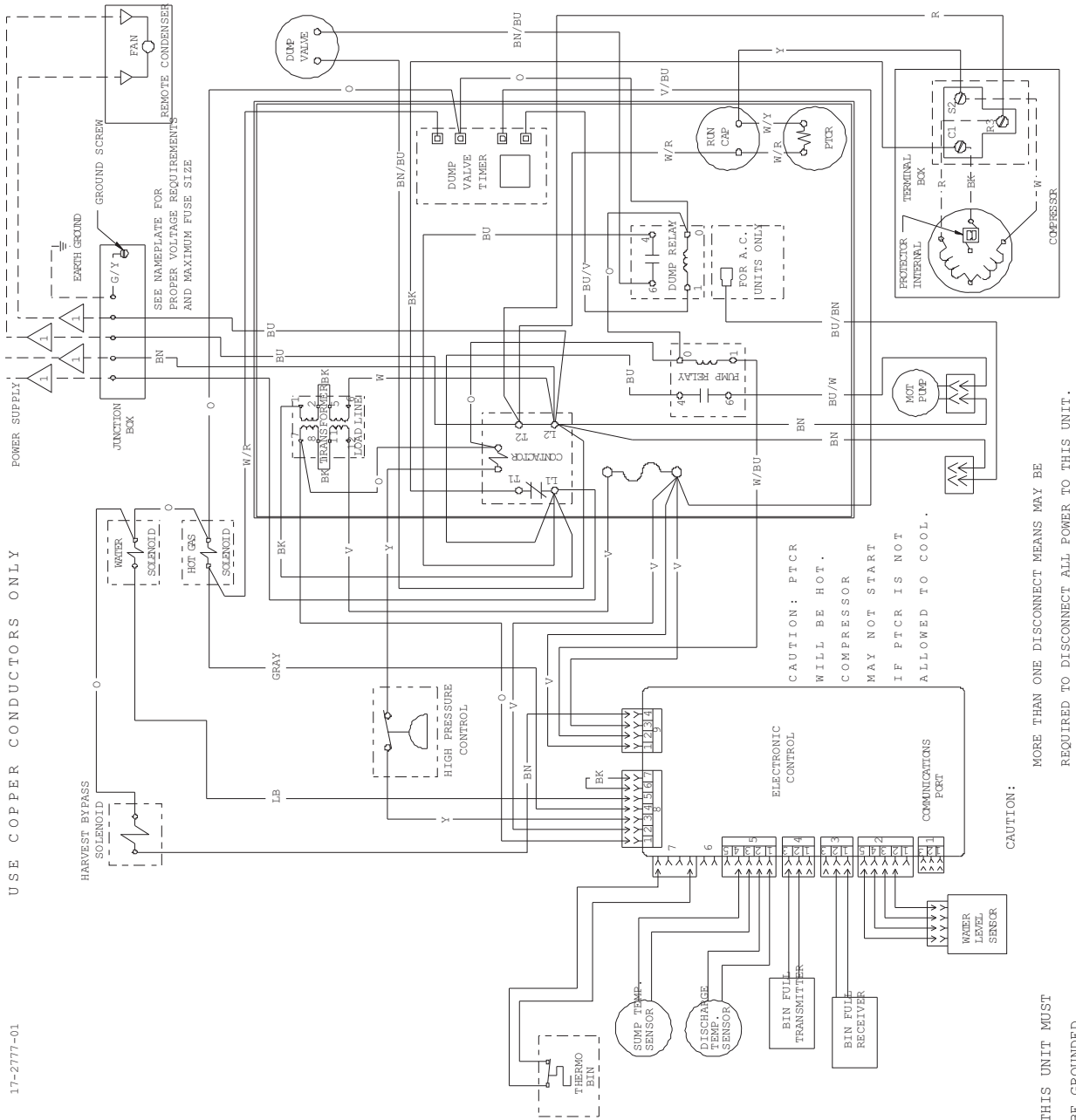
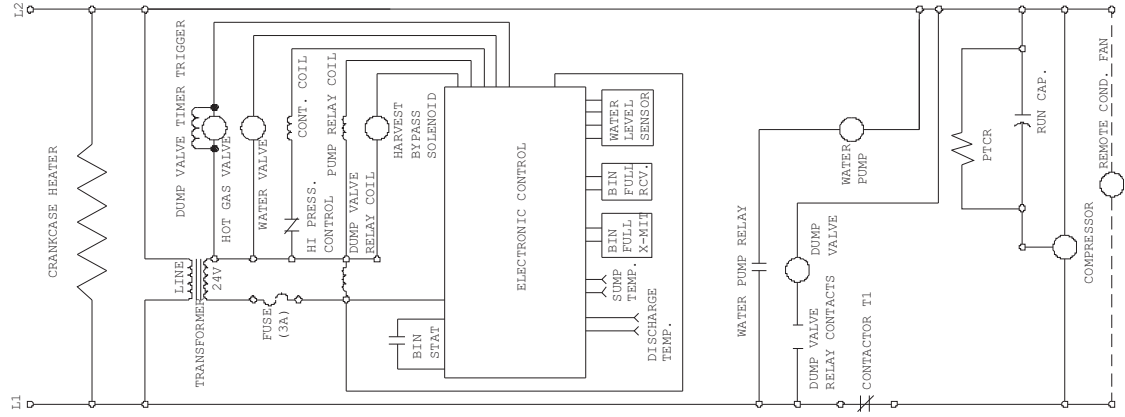

17-2777-01

USE COPPER CONDUCTORS ONLY

POWER SUPPLY

▲ DASHED LINES INDICATE FIELD WIRING WHICH MUST BE INSTALLED IN ACCORDANCE WITH THE NATIONAL ELECTRICAL CODE AND ALL STATE AND LOCAL CODES.

THIS UNIT MUST BE GROUNDED.

CAUTION: MORE THAN ONE DISCONNECT MEANS MAY BE REQUIRED TO DISCONNECT ALL POWER TO THIS UNIT.

CAUTION: PTCR WILL BE HOT. COMPRESSOR MAY NOT START IF PTCR IS NOT ALLOWED TO COOL.

CME1356R and CME1656R Service Parts

Single Phase Wiring Diagram

17-2504-01

USE COPPER CONDUCTORS ONLY

⚠ DASHED LINES INDICATE FIELD WIRING WHICH MUST BE INSTALLED IN ACCORDANCE WITH THE NATIONAL ELECTRICAL CODE AND ALL STATE AND LOCAL CODES.

⚠ WIRE COLOR FOR 208-230/60/1 UNITS: BLACK
WIRE COLOR FOR 230/50/1 UNITS: BROWN

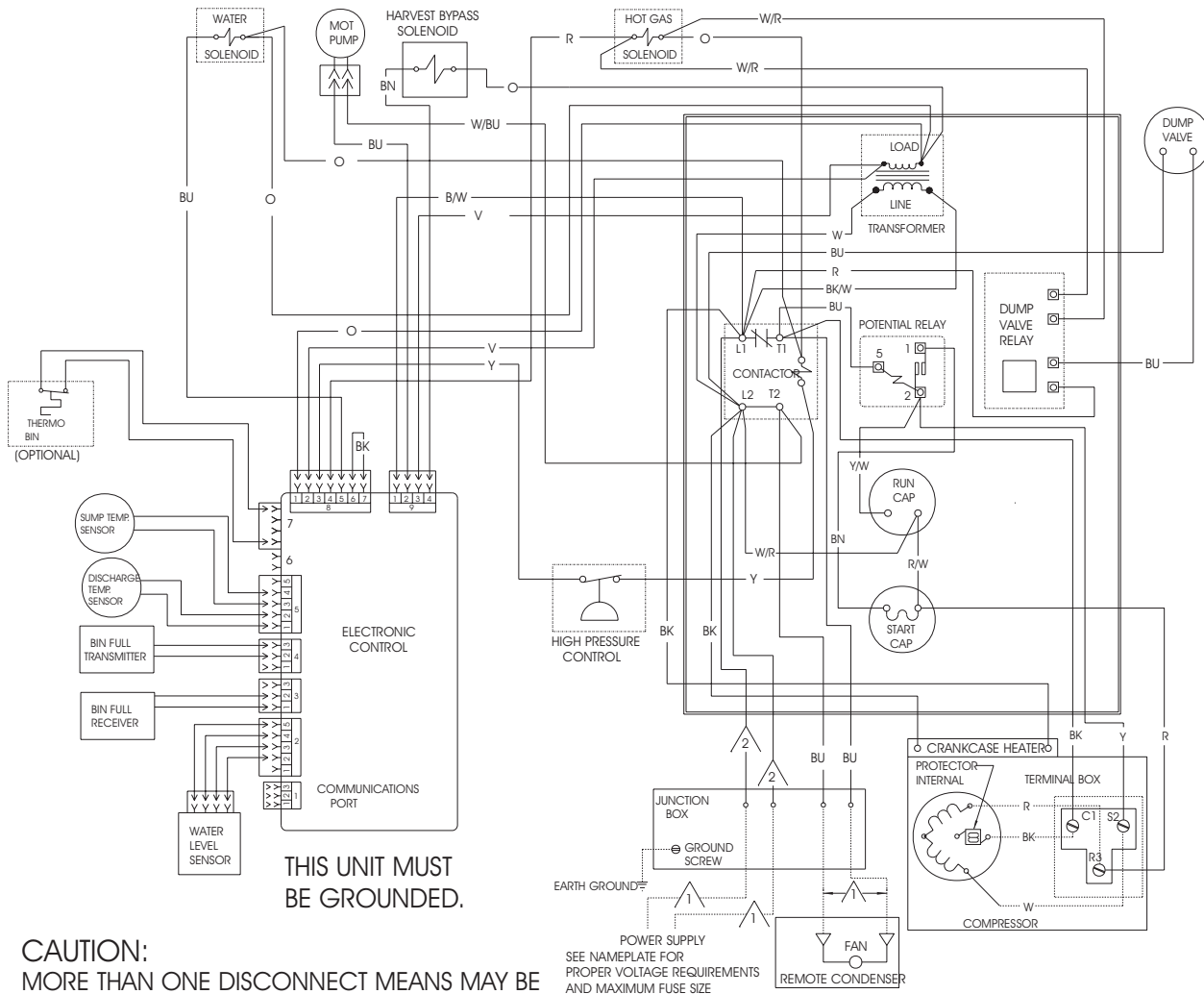

CME1356R and CME1656R Service Parts

Single Phase Schematic Diagram

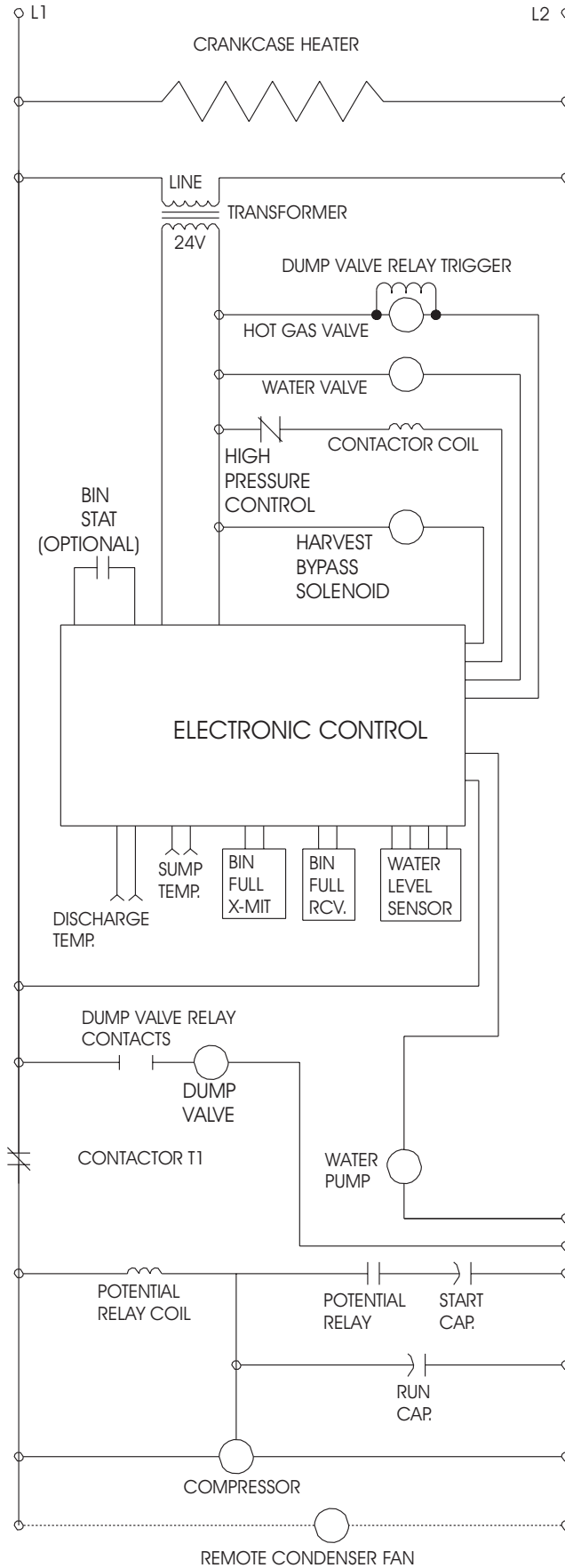

CME1356R and CME1656R Service Parts

Three Phase Wiring Diagram

17-2513-03

USE COPPER CONDUCTORS ONLY

△ DASHED LINES INDICATE FIELD WIRING WHICH MUST BE INSTALLED IN ACCORDANCE WITH THE NATIONAL ELECTRICAL CODE AND ALL STATE AND LOCAL CODES.

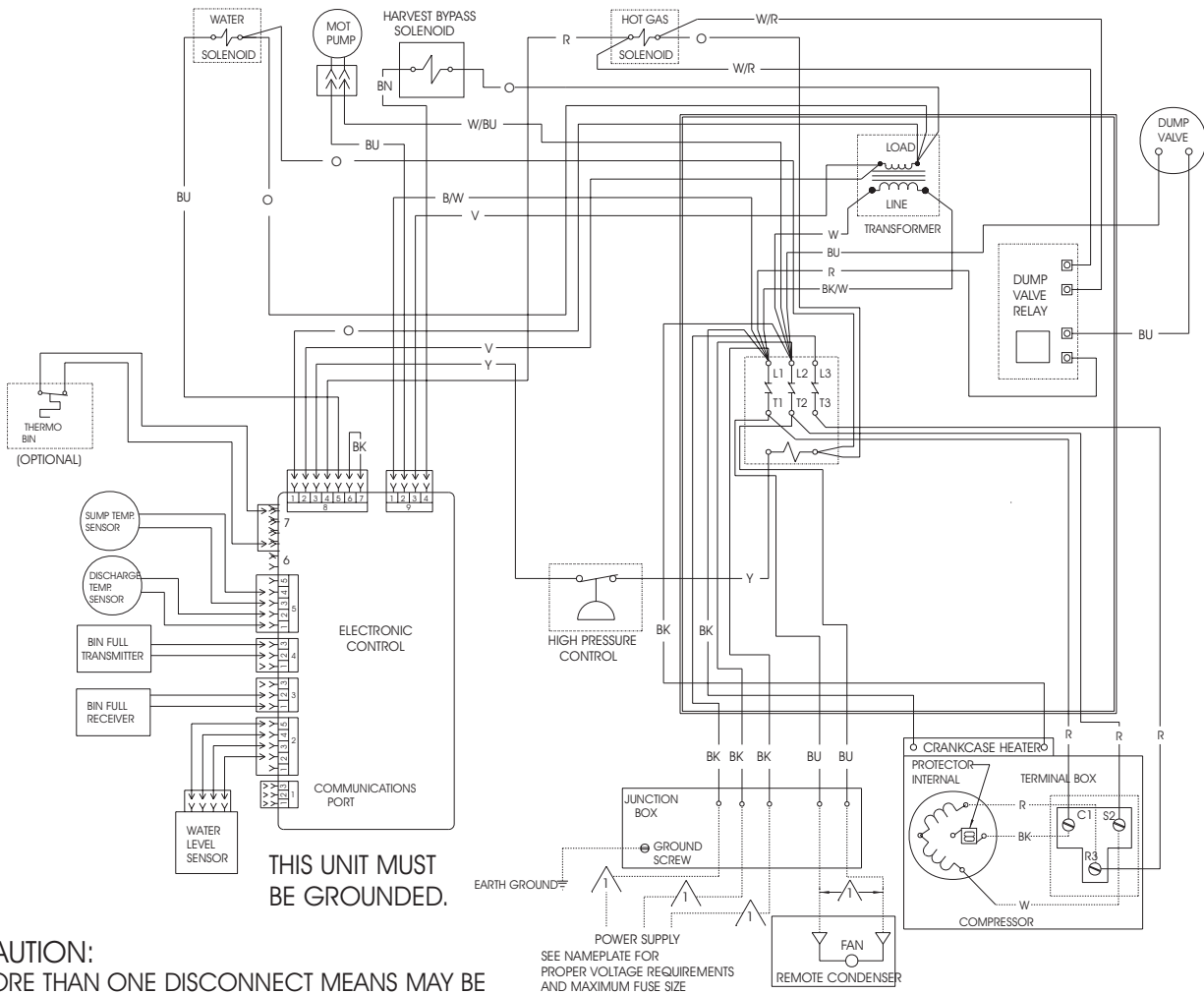

CME1356R and CME1656R Service Parts

Three Phase Schematic Diagram

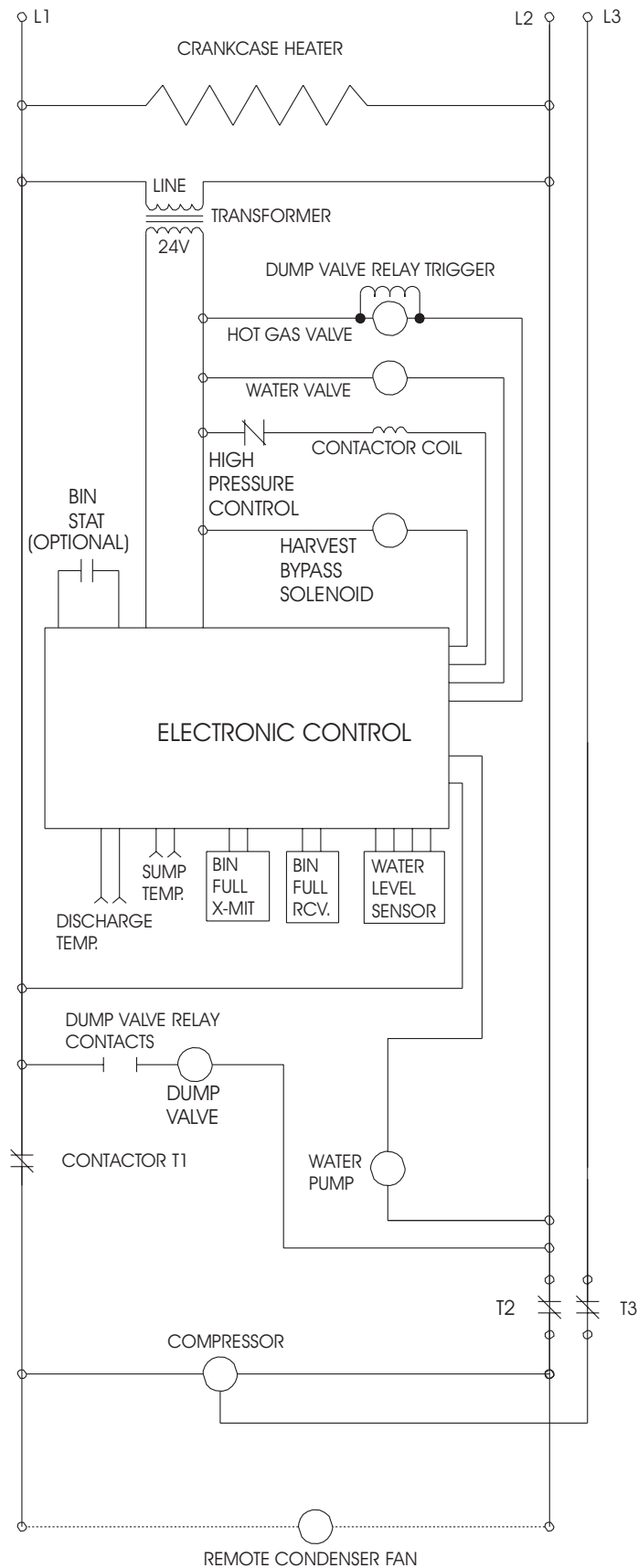

SERVICE BULLETIN

Subject: Controller Cover

Affects all versions of models: CME1356, CME1656, CME1856 and CME2006

The above models are now manufactured with a sheet metal cover over the top of the controller.

Service controllers also are now shipped with a cover that should be applied to these models whenever replacing the controller if the machine does not already have a cover installed.

Whenever cleaning or servicing any unit, check to see whether it has a cover over the controller like the one shown below. If it does not, Scotsman recommends installing a cover. A separate part is now available for this purpose. Its part number is **A37480-021**. It mounts over the top end of the controller and is secured by two sheet metal screws. Use the cover as a template and drill two 1/8" holes for the two screws.

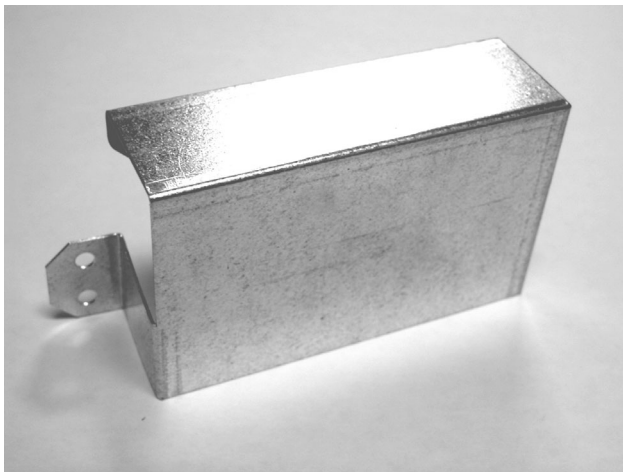

Controller Cover



Cover Installed on Unit

Scotsman is shipping a supply of covers to all Scotsman Distributors and listed service agencies. A supply of covers should be carried by each service person on service calls so a cover may be installed on the unit being cleaned or serviced if one is not already in place. Additional covers may be obtained free of charge from Scotsman, through the local Scotsman Distributor, as needed.