

TAV.205		Struttura	Structure	Structure	Struktur	FEC100	FEP080	FEM100/101
Codice	Denominazione	Denominaton	Denominaton	Denominaton	Bezeichnung			
1	GAFOC00052	Cassone forno	Caisson du four	Oven body	Ofenschublade	x	x	x
2	RTCU700002	Attacco griglia laterale	Attaque latérale	Lateral connection	Seitenanschluß	x	x	x
3	GAFOC00027	Disco copriforo	Disque	Disk	Scheibe	x	x	x
4	GAFOC00030	Cerniera superiore porta	Charnière supérieure	Upper hinge	Linke Türangel	x	x	x
5	GAFOC00031	Cerniera inferiore porta	Carnière inférieure	Lower door hinge	Untere Türangel	x	x	x
6	MPGOM03P00	Guarnizione vetro porta	Guarniture porte du four	Oven door gasket	Türdichtung	x	x	x
7	GAFOC00049	Porta forno	Porte du four	Oven door	Ofentür	x	x	x
8	RTFOC00065	Cristallo porta forno	Verre porte four	Oven door glass	Ofentürglas	x	x	x
9	RTFOC00007	Maniglia serratura	Poignée porte four	Oven door handle	Ofentürgriff	x	x	x
10	PAFOC00064	Controporta forno	Contre porte du four	Oven counter door	Gegentür	x	x	x
11	PAFOC00063	Protezione settura porta	Protection de la serrure	Lock guard	Schloßschutz	x	x	x
12	PAFOC00039	Prolunga sinistra facciata	Rollonge gauche facade	Left facade extension	Verlängerung linke Front	x	x	x
13	RTFOC00094	Guarnizione porta forno	Guarniture porte du four	Oven door gasket	Türdichtung	x	x	x
13	GRFOC00198				Türdichtung NEU			
14	GAFOC00048	Cassetto	Tiroir	Drawer	Kasten	x	x	x
15	PAFOC00181	Traversa antigoccia	Traverse anti-goutte	Anti-drip crosspiece	Tropfschutzquerstange	x	x	x
16	PAFOC00038	Prolunga destra facciata	Rollonge droite facade	Right facade extension	Verlängerung rechte Front	x	x	x
17	PAFOC00025	Coprilana inferiore	Panneau couvre isolant	Insulating panel cover	Isoliermaterialverkleidung	x	x	x
18	PACU800150	Pannello isolante	Panneau isolant	Insulating panel	Isolierplatte	x	x	x
19	GAFOC00040	Basamento	Soubassement	Base	Untergestell	x	x	x
20	GAFOC00055	Cruscotto	Panneau de contrôle	Control panel	Stirnbrett	x	x	x
21	RTFOC00035	Microinterruttore	Microswitch	Microswitch	Microswitch	x	x	x
22	PAFOC00066	Coprilana destro	Panneau couvre isolant	Insulating panel cover	Isoliermaterialverkleidung	x	x	x
23	RTFOC00051	Piedino	Pied	Foot	Inox-Fuß	x	x	x
24	PAFOC00068	Fianco inox	Côté inox	Inox side	Inox-Seite	x	x	x
25	GAFOC00053	Supporto ventola	Support ventilateur	Fan support	Lautrdsupport	x	x	x
26	PAFOC00026	Coprilana inf. posteriore	Panneau couvre isolant	Insulating panel cover	Isoliermaterialverkleidung	x	x	x
27	PAFOC00067	Coprilana posteriore	Panneau couvre isolant	Insulating panel cover	Isoliermaterialverkleidung	x	x	x
28	GAFOC00089	Posteriore inox	Panneau postérieur inox	Inox back panel	Inox-Rückwand	x	x	x
29	PAFOC00065	Coprilana sinistro	Panneau couvre isolant	Insulating panel cover	Isoliermaterialverkleidung	x	x	x
30	PAFOC00137	Protezione comp. elettrici	Protection composant électriques	Electrical components guard	Schutz elektronische Komponenten	x	x	x
31	PAFOC00140	Coprilana superiore	Panneau couvre isolant	Insulating panel cover	Isoliermaterialverkleidung	x	x	x
32	GAFOC00103	Coperchio	Couvercle	Cover	Topfdeckel	x	x	
32	GAFOC00090	Coperchio	Couvercle	Cover	Topfdeckel			x
33	GAFOC00051	Serratura porta forno	Serrure porte four	Over door lock	Ofentürschloß	x	x	x
34	RTFOC00057	Zoccolo centrale serratura	Prise centrale serrure	Central connection lock	Mittlerer Anschluß	x	x	x
35	RTFOC00005	Zoccolo esterno serratura	Prise extérieure serrure	External connection lock	Äußerer Anschluß	x	x	x
36	RTFOC00009	Gancio fisso serratura	Crochet fixe de la serrure	Lock fixed hook	Fester Schloßnaken	x	x	x
37	RTBF800021	Gommino porta forno	Bouchon de la porte	Door rubber cap	Türgummi	x	x	x
38	RTFOC00202	Guarnizione portalamпада	Guarniture	Gasket	Dichtung	x	x	x
39	RTFOC00201	Vetro portalamпада	Verre protège ampoule	Lamp-holden glass	Leuchtenhalterungsglas	x	x	x
40	RTFOC00037	Lampada 25W 220V	Ampoule 25W 220V	Lamp 25W 220V	Leuchte 25W 220V	x	x	x
41	RTFOC00036	Portalamпада	Douille	Lamp-holder	Leuchtenhalterung	x	x	x
42	RTFOC00078	Asta posteriore scarico cond.	Antenne arrière	Rear rod	Hintere Stange	x	x	x
43	RTFOC00109	Asta trasversale scarico cond.	Antenne transversale	Transverse rod	Querstange	x	x	x

TAV.205		Struttura	Structure	Structure	Struktur	FEC100	FEP080	FEM100/101
	Codice	Denominazione	Denominaton	Denominaton	Bezeichnung			
44	RTFOC00056	Manopola scarico condensa.	Manette évacuation condens.	Moisture drain knob	Drehknopf Kondenswasserablaß	×	×	×
45	RTFOC00080	Asta anteriore scarico cond.	Antenne avant	Front rod	Vordere Stange	×	×	×
46	RTFOC00301	Anello tenuta perno motore	Rondelle de joint	Ring	Ring	×	×	×
47	RTFOC00124	Gomito scarico condens.	Coude évacuation condensation	Moisture drain elbow	Kondenswasserkniestück	×	×	×
48	RTFOC00077	Asta posteriore scarico condens.	Antenne arrière	Rear rod	Hintere Stange	×	×	×
49	RTFOC00052	Rampa scarico condens.	Rampe évacuation conensation	Moisture drain ramp	Kondenswasserablaßrampe	×	×	
49	RTFOC00152	Rampa scarico condens.	Rampe évacuation conensation	Moisture drain ramp	Kondenswasserablaßrampe			×

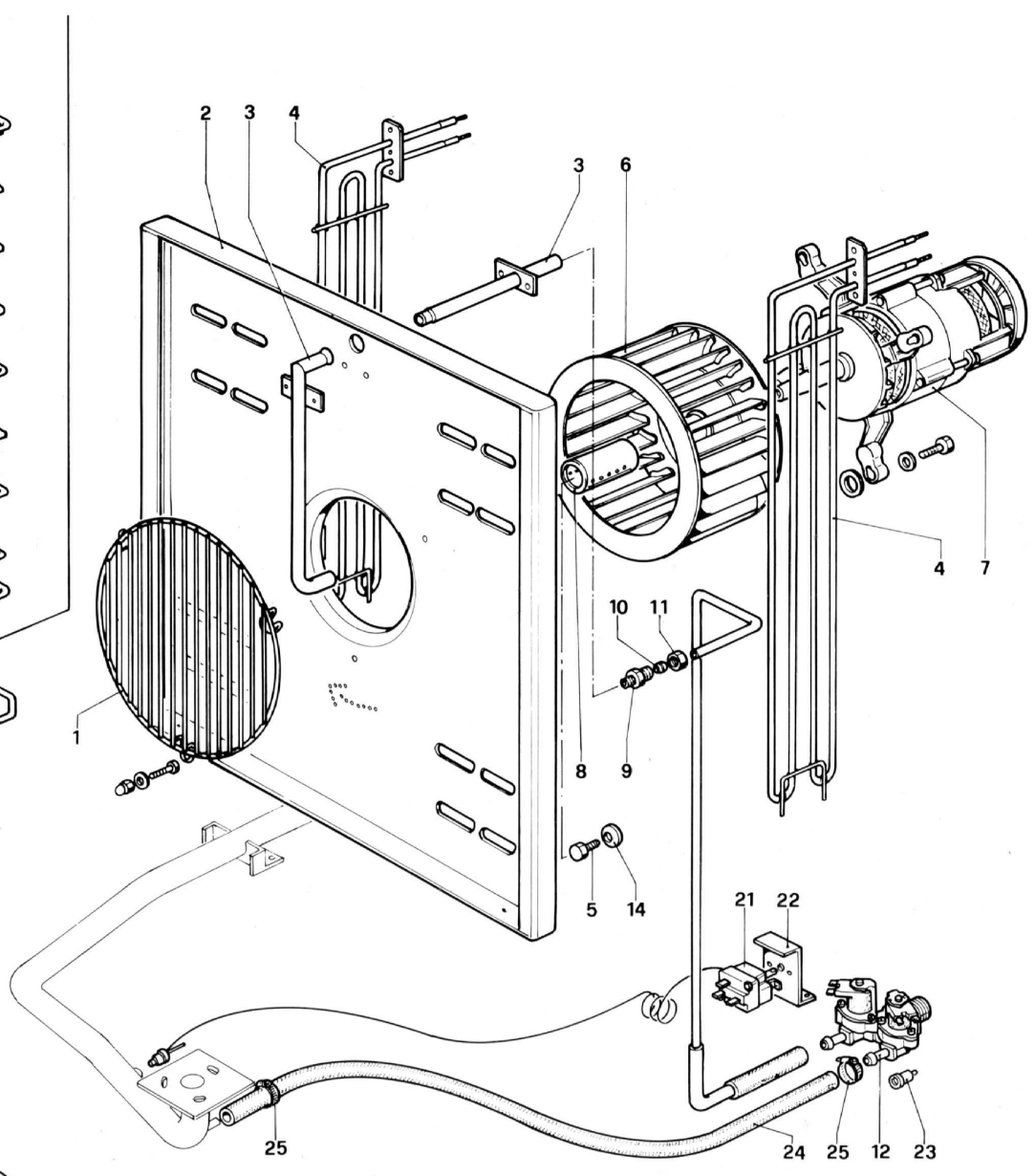
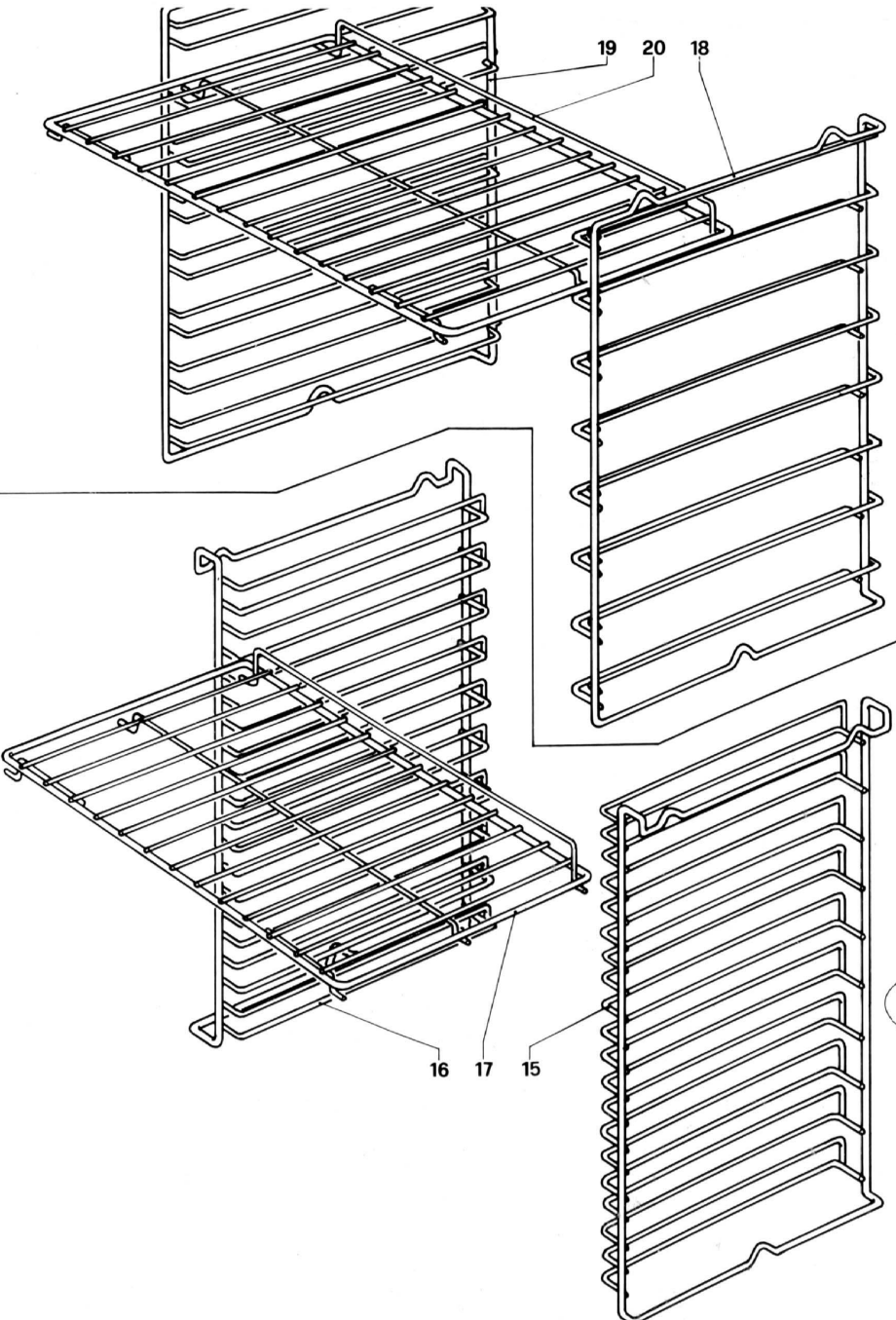

TAV.206		Griglie e ventilazione	Grilles et ventilation	Grilles and ventilation	Gitter und Belüftung	FEC100	FEP080	FEM100/101/102
Codice	Denominazione	Denominaton	Denominaton	Bezeichnung				
1	RTFOC00014	Griglia protezione ventilatore	Grille ventilateur	Fan grille	Ventilatorgitter	x	x	x
2	GAFOC00067	Convogliatore aria	Coiffée ventilateur air	Air duct	Luftförderer	x	x	x
3	RTFOC00071	Umidificatore	Humidificateur	Humidifier	Befeuchter	x	x	x
4	RTFOC00068	Resistenza elettr. 2500W 230V	Resistance elect. 2500W 230V	Over heating elect. 2500W 240V	Elektr. Widerstand 2500W 240V	x	x	x
5	RTFOC00118	Vite fissaggio girante	Vis de fixation couronne mobile	Wheel attachment serews	Laufradbefestigungsschraube	x	x	x
6	RTFOC00067	Girante ventilatore	Couronne mobile ventilateur	Fan wheel	Ventilatorlaufrad	x	x	x
7	RTFOC00066	Motore elettrico	Moteur électrique	Electric motor	E-Motor	x	x	x
8	RTFOC00156	Nebulizzatore	Nébulisateur	Atomizer	Zersträuber	x	x	x
9	RTFOC00019	Iniettore umidificatore	Injecteur humidificateur	Injecteur for humidifier	Einspritzer für Befeuchter	x	x	x
10	RTCU800183	Bicone Ø 6	Bicone pour tube Ø 6	Bicone for pipe Ø 6	Zweikegel Ø 6	x	x	x
11	RTFOC00020	Calotta Ø 6	Ecron pour tube Ø 6	Nut for pipe Ø 6	Mutter für Schlauch Ø 6	x	x	x
12	RTFOC00022	Elettrovalvola 2 vie	Electrovanne 2 voies	Solenoid valve 2 ways	E-Ventil	x	x	x
13	RTFOC00072	Tube alimentazione umidif.	Tube alimentation	Feeding pipe	Versorgungsrohr	x	x	x
15	RTFOC00070	Griglia laterale destra	Grille latérale droite	Right lateral grate	Rechter Seitenrost	x		
15	RTFOC00178	Griglia laterale destra	Grille latérale droite	Right lateral grate	Rechter Seitenrost			x
16	RTFOC00069	Griglia laterale sinistra	Grille latérale gauche	Left lateral grate	Linker Seitenrost	x		
16	RTFOC00181	Griglia laterale sinistra (FEM101)	Grille latérale gauche (FEM101)	Left lateral grate (FEM101)	Linker Seitenrost (FEM101)			x
16	RTFOC00179	Griglia laterale sinistra (FEM100)	Grille latérale gauche (FEM100)	Left lateral grate /FEM100)	Linker Seitenrost			x
17	RTFOC00017	Griglia forno	Grille du four	Oven grate	Ofenrost	x		
17	RTFOC00175	Griglia forno	Grille du four	Oven grate	Ofenrost			x
18	RTFOC00114	Griglia laterale destra	Grille letérale droite	Right lateral grate	Rechter Seitenrost		x	
19	RTFOC00113	Griglia laterale sinistra	Grille latérale gauche	Left lateral grate	Linker Seitenrost		x	
20	RTFOC00083	Griglia forno	Grille du four	Oven grate	Ofenrost		x	
21	RTFOC00275	Termostato elettrico	Thermostat	Thermostat	Thermostat	x	x	x
22	PACP800062	Squadrette portatermostato	Eguerre de fixation thermostat	Bracket to fix thermostat	Winkel	x	x	x
23	RTFOC00120	Regolatore elettrovalvola Ø 0,25	Regulateur electrovanne Ø 0,25	Solenoid valve regulator Ø 0,25	E-Ventil Regler Ø 0,25	x	x	x
24	MPGOM10T00	Tube gomma Ø 10x17	Tuyau Ø 10x17	Pipe Ø 10x17	Rohr Ø 10x17	x	x	x
25	RTMIN00221	Fascetta Ø 14-22	Collier Ø 14-22	Clamp Ø 14-22	Windel Ø 14-22	x	x	x

TAV.213		Boiler elettrico	Bouilleur electric	Electric boiler	Elektroboiler	FEM100/101	FMM100/101
	Codice	Denominazione	Denominaton	Denominaton	Bezeichnung		
1	GAFOC00084	Boiler elettrico	Bouilleur electric	Electric boiler	Elektroboiler	×	×
2	RTFOC00186	Dado 3/4"	Ecrou 3/4"	Nut 3/4"	Mutter 3/4"	×	×
3	RTCU900012	Bicono Ø 10	Bicone Ø 10	Bicone Ø 10	Zweikegel Ø 10	×	×
4	RTFOC00224	Tubo carico acqua	Tube alimentation eau	Water feeding pipe	Versorgungsrohr	×	×
5	RTCU900013	Raccordo Ø 10	Ecrou Ø 10	Nut Ø 10	Mutter Ø 10	×	×
6	MPISO00011	Isolante	Panneau isolant	Insulating panel	Isolier tafel	×	×
7	RTFOC00120	Regolatore elettrovalvola Ø 0,25	Régulateur electrovanne Ø 0,25	Solenoid valve regulator Ø 0,25	E-Ventil Regler Ø 0,25	×	×
8	RTFOC00022	Elettrovalvola 1 via	Electrovanne 1 voie	Solenoid valve 1 way	E-Ventil	×	×
9	RTFOC00149	Sonda livello 210mm	Sonde niveau 210mm	Level probe 210mm	Niveaufühler 210mm	×	×
10	RTFOC00255	Sonda livello 190mm	Sonde niveau 190mm	Level probe 190mm	Niveaufühler 190mm	×	×
11	RTFOC00166	Asta rubinetto boiler	Antenne robinet de decharge	Tap rod	Ablaßhahnstange	×	
11	RTFOC00138	Asta rubinetto boiler	Antenne robinet de decharge	Tap rod	Ablaßhahnstange		×
12	RTFOC00150	Resistenza elettrica 7,5kW 230V	Resistance électrique 7500W 230V	Oven heating electric 7500W 230V	Elektr. Widerstand 7500W 230V	×	×
13	RTCP900034	Gomito MF 1/2"	Raccord MF 1/2"	Elbow 1/2"	Kniestück 1/2"	×	×
14	RTFOC00136	Rubinetto scarico	Robinet de decharge	Water discharge tap	Ablaßhahn	×	×
15	PACP800010	Tubo flessibile	Tube flexible	Flexible pipe	Wasserablaßrohr	×	×
16	PAFOC00204	Tubo scarico acqua	Tube de decharge de l'eau	Water discharge pipe	Wasserablaßrohr	×	×
17	RTCP900088	Bicono Ø 14	Bicone pour tube Ø 14	Bicone for pipe Ø 14	Zweikegel Ø 14	×	×
18	RTCP900089	Calotta per tubo Ø 14	Ecrou pour tuyau Ø 14	Nut for pipe Ø 14	Mutter für Schlauch Ø 14	×	×
19	RTCP900087	Nipples 1/2"-M20	Nipples 1/2"-M20	Nipples 1/2"-M20	Nippel 1/2"-M20	×	×
20	RTFOC00056	Manopola scarico	Manette évacuation	Drain knob	Drehknopf	×	×
21	RTFOC00213	Guarnizione valvola peso	Guarniture valve	Valve gasket	Dichtung	×	×
22	RTFOC00212	Valvola peso	Valve	Valve	Ventil	×	×
23	MPGOM10T00	Tubo gomma Ø 10x17	Tuyau Ø 10x17	Pipe Ø 10x17	Rohr Ø 10x17	×	×
24	RTFOC00275	Termostato elettrico	Thermostat	Thermostat	Thermostat	×	×
25	PAFOC800062	Squadretta portatermostato	Egierre de fixation thermostat	Bracket to fix thermostat	Winkel	×	×
26	RTMIN00221	Fascetta Ø 14-22	Collier Ø 14-22	Clamp Ø 14-22	Windel Ø 14-22	×	×
27	RTFOC00145	Regolatore elettrovalvola Ø 1,20	Regulateur electrovanne Ø 1,20	Solenoid valve regulator Ø 1,20	E-Ventil Regler Ø 1,20	×	×
28	RTFOC00203	Elettrovalvola 2 vie	Electrovanne 2 voies	Solenoid valve 2 ways	E-Ventil	×	×

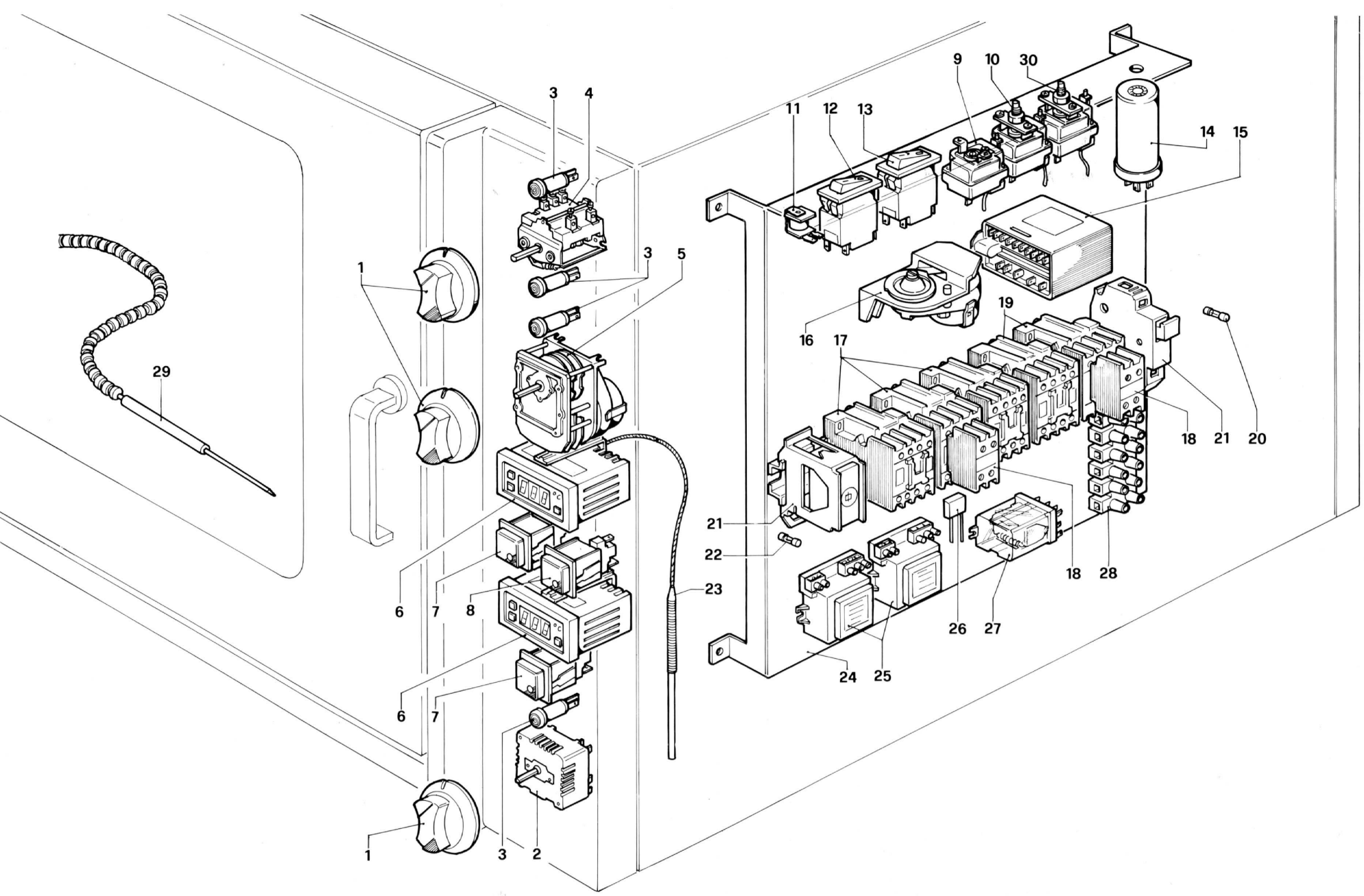

TAV.214		Apparecchiature elettriche	Appareillages électriques	Electrical equipment	Elektrogeräte	FEM060	FEM061	FEM100	FEM101
	Codice	Denominazione	Denominaton	Denominaton	Bezeichnung				
1	RTFOC00055	Manopola comando	Manette de comande	Control knob	Steuerdrehknopf	x	x	x	x
2	RTCU800066	Regolatore d'energia	Régulateur d'énergie	Power regulator	Energieregler	x	x	x	x
3	RTCU900072	Lampada spia gialla	Lampe témoin jaune	Yellow warning lamp	Gelbe konntrolleuchtenbirne	x	x	x	x
4	RTFOC00143	Commutatore	Commutateur du four	Oven warning lamp	Kommutator	x	x	x	x
5	RTFOC00030	Timer	Timer	Timer	Timer	x	x	x	x
6	RTFOC00029	Termostato elettronico	Thermostat électronique	Electronic thermostat	Elektra-Thermostat	x	x	x	x
7	RTFOC00033	Pulsante 2 velocità	Bouton 2 vitesses	Two-speed button	Taste 2 geschwind	x	x	x	x
8	RTFOC00032	Pulsante luce	Bouton lumière	Light button	Lichttaste	x	x	x	x
9	RTFOC00147	Termostato	Thermostat	Thermostat	Thermostat	x	x	x	x
10	RTFOC00173	Termostato Limit	Thermostat Limit	Limit thermostat	Limit Thermostat	x	x	x	x
11	RTFOC00046	Ronzatore	Bourdonneur	Buzzer	Summer	x	x	x	x
12	RTFOC00044	Termica 0,8A	Interrupteur thermique 0,8A	Overload switch 0,8A	Thermoschutzschalter 0,8A	x	x		
12	RTFOC00129	Termica 0,6A	Interrupteur thermique 0,6A	Overload switch0,6A	Thermoschutzschalter 0,6A			x	x
13	RTFOC00045	Termica3A	Interrupteur thermique 3A	Overload switch 3A	Thermoschutzschalter 3A	x	x		
13	RTFOC00074	Termica 1,6A	Interrupteur thermique 1,6A	Overload switch 1,6A	Thermoschutzhalter1,6A			x	x
14	RTFOC00053	Condensatore	Condensateur	Condensator	Kondensator	x	x	x	x
15	RTFOC00146	Centralina boiler	Boîte de commandes électronique	Electronic control box	Steuereinheit	x	x	x	x
16	RTFOC00042	Ciclatore 50Hz	Cycleur 50Hz	Buzzer 50Hz	Taktvorrichtung 50Hz	x	x	x	x
17	RTFOC00040	Relais FCV	Relais FCV	Relais FCV	Relais FCV	x	x		
17	RTBF800153	Relais	Relais	Relais	Relais			x	x
18	RTFOC00041	Contatti ausilari	Contacts auxiliaires	Auxiliary contacts	Nebenkontakte	x	x	x	x
19	RTFOC00171	Relais	Relais	Relais	Relais	x	x	x	x
20	RTFOC00024	Fusibile 2,5A	Fusibile 2,5A	Fuse 2,5A	Schmelzsicherung 2,5A	x	x	x	x
21	RTFOC00048	Portafusibile	Porte-fusibile	Fuse-holder	Sicherungsschalter	x	x	x	x
22	RTFOC00047	Fusibile 0,1A	Fusibile 0,1A	Fuse 0,1A	Schmelzsicherung 0,1A	x	x	x	x
23	RTFOC00034	Termocoppia 100cm	Thermocouple 100cm	Thermocouple 100cm	Thermoelement 100cm	x	x	x	x
24	PAFOC00029	Supporto componenti elettrici	Support composants électriques	Electronic components support	Halterung elektrischer Komponenten	x	x	x	x
25	RTFOC00039	Transformatore 220/12V	Transformateur el. 220/ 12V	Electric transformator 220/12V	Transformator 220/12V	x	x	x	x
26	RTFOC00023	Antidisturbo radio	Antiparasitage radio	Antijamming	Funkenstörung	x	x	x	x
27	RTFOC00144	Relais boiler	Relais bouilleur	Boiler relais	Relais	x	x	x	x
28	RTBF900045	Morsetteriera 6 poli	Groupe de com. des cables	Terminal bloc 6 poles	Klemmbrett 6 polig	x	x	x	x
29	RTFOC00130	Sonda al cuore 55cm	Sonde thermique 55cm	Thermic probe 55cm	Wärmefühler 55cm	x	x		
29	RTFOC00131	Sonda al cuore 82cm	Sonde therique 82cm	Thermic probe 82cm	Wärmefühler 82 cm			x	x
30	RTFOC00038	Termostato Limit	Thermostat limit	Limit thermostat	Limit Thermostat	x	x	x	x

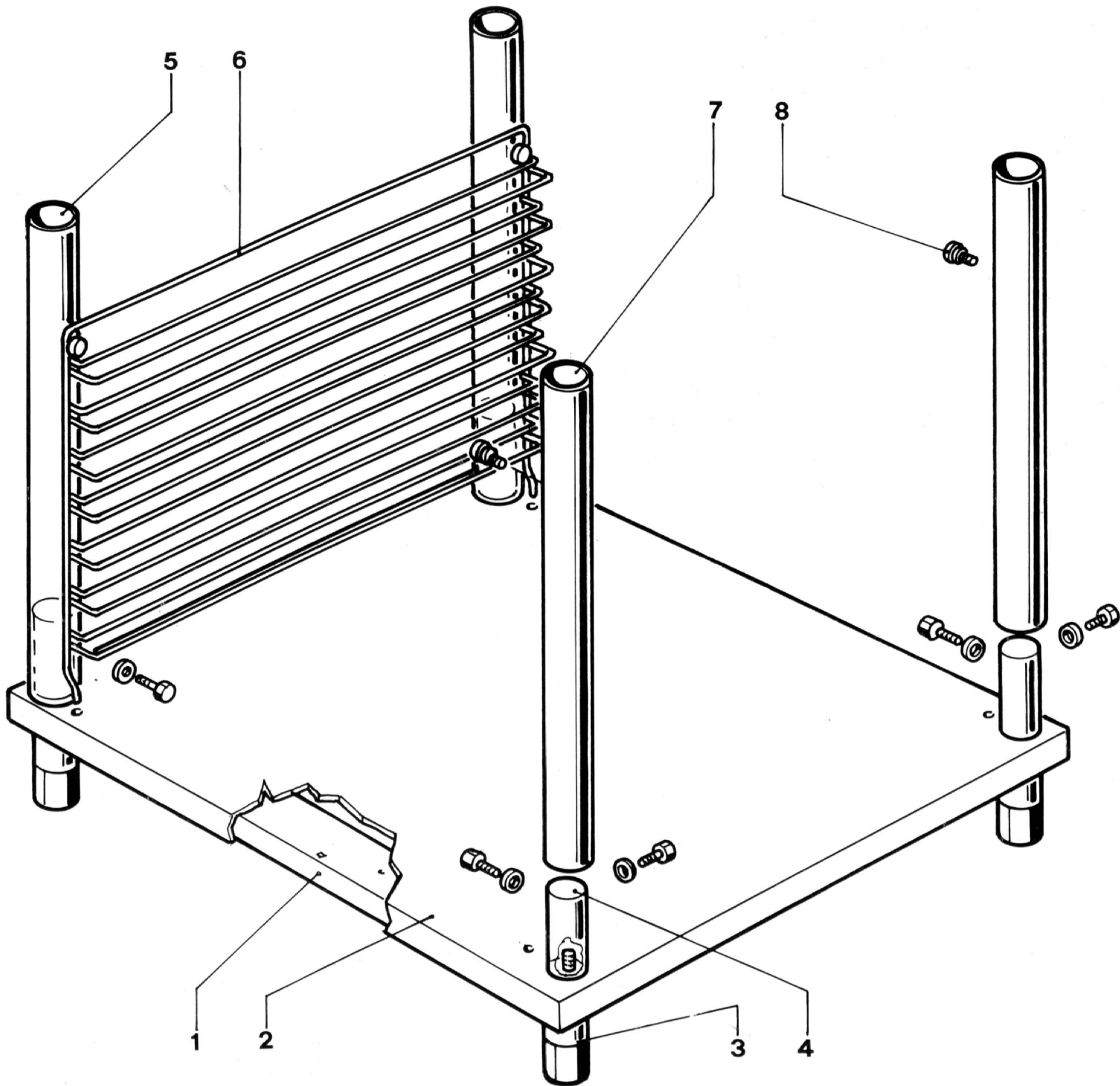

TAV.204		Supporto forno	Support du four	Oven support	Ofenhalterung	
	Codice	Denominazione	Denominaton	Denominaton	Bezeichnung	
1	GAFOC00077	Basamento supporto forno	Soubassement du support	Oven support base	Untergestell	×
2	PAFOC00133	Ripiano supporto forno	Fonde support du four	Oven support bottom	Boden	×
3	RTFOC00119	Piedino	Pied	Foot	Inox-Fuß	×
4	RTFOC00121	Rinforzo gamba	Rentort jambe	Leg bracing	Verstärkung	×
5	PAFOC00134	Gamba sinistra	Jambe gauche	Left leg	Linker Fuß	×
6	RTFOC00122	Griglia laterale	Grille latérale	Lateral grate	Seitenrost	×
7	PAFOC00135	Gamba destra	Jambe droite	Right leg	Rechter Fuß	×
8	RTBF700043	Attacco griglia	Attaque grille	Grate connection	Seitenanschluß	×