



Fresh Maker

LIST OF THE EXPLODED VIEWS



SHELL ASSY

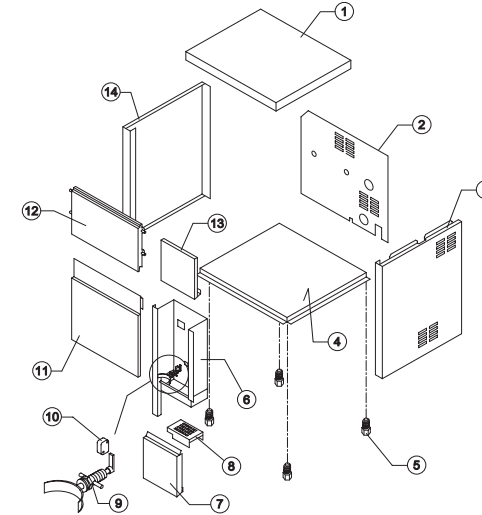

COOLING SYSTEM

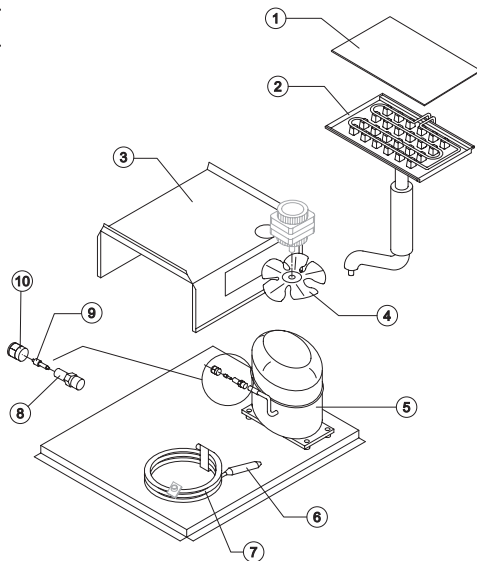

HYDRAULIC CIRCUIT

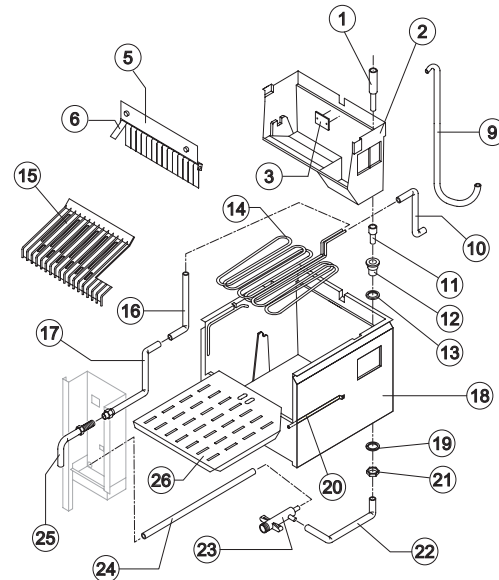

SPRAYER PUMP

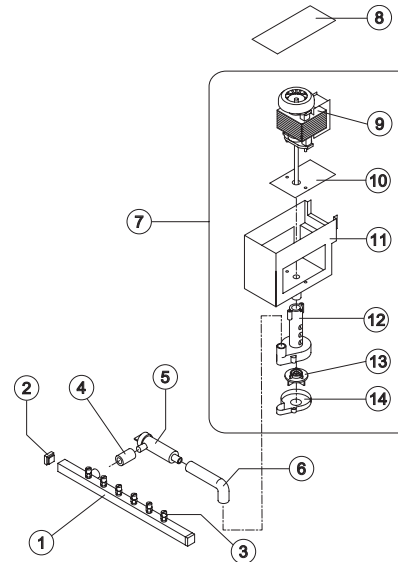

ELECTRIC PARTS

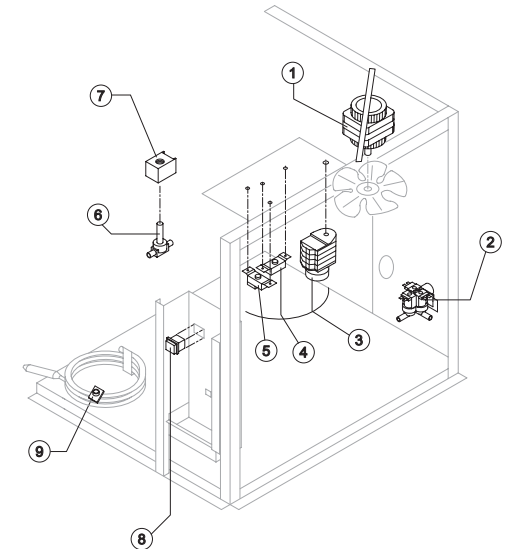

Rev. 3 - 20/10/2003

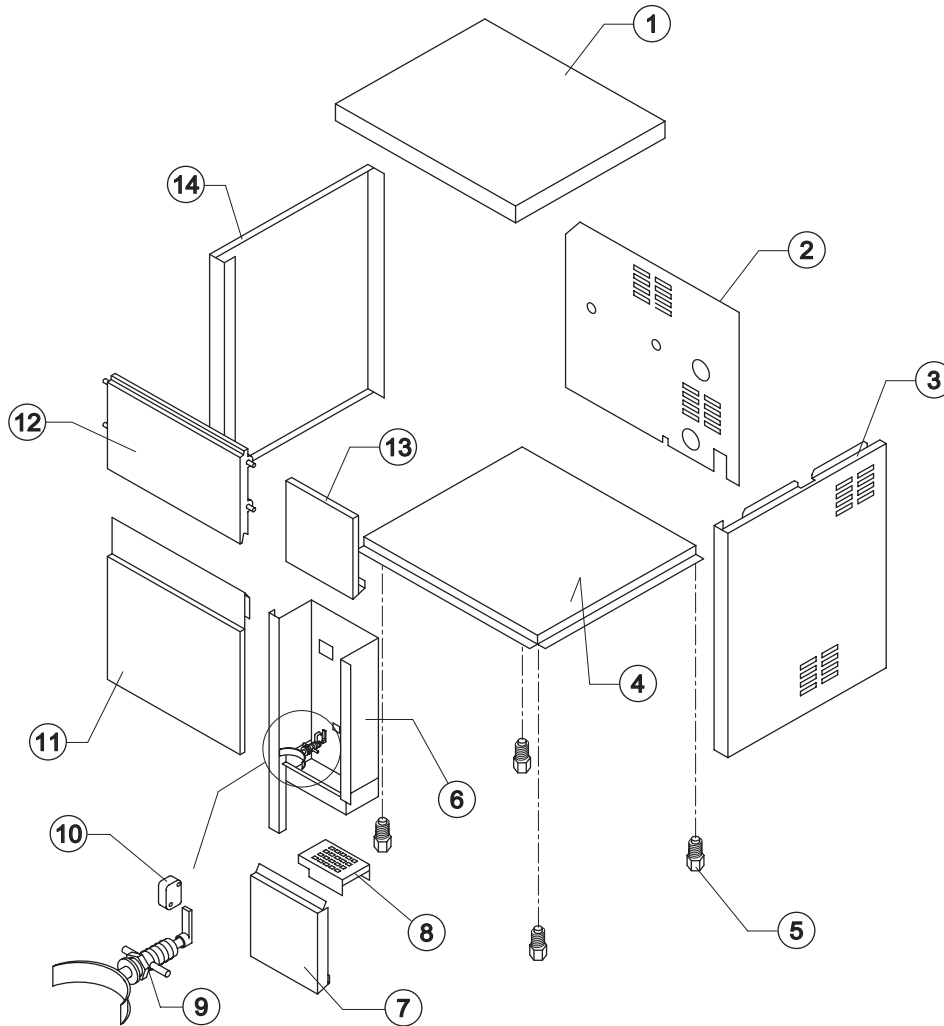

Ref.	Spare Description	Code
1	Top Assembly	C22199
2	Back Panel	22198
3	Right Side	22200
4	Base Plate	21105
5	Foot	10017
6	Ice Dispenser Panel	22273
7	Basin Cover Panel	22190
8	Glass Support	22183
9	Push Ice Dispenser Assembly	C26544
10	Microswitch	23055
11	Front Panel (Bin Side)	22189
12	Dark Grey Door	10277
13	Faucet Cover	22197
14	Left Side	22201

Rev. 3 - 20/10/2003

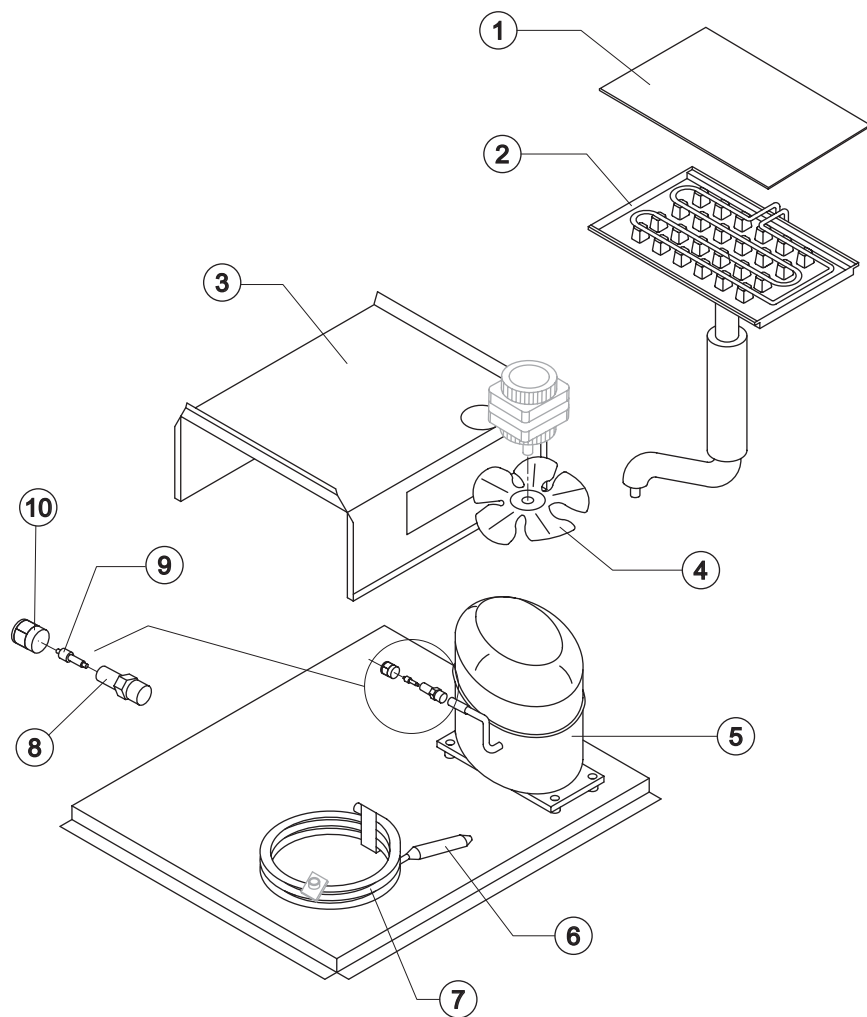

Ref.	Spare Description	Code
1	Evaporator Cover	10076
2	Evaporator	D10079
3	Bin Support Saddle	21108
4	Pressing Fan Blade	20193
5	Compressor	See Table
6	Molecular Drier	14009
7	Water Condenser	14100
8	Vacuum-Charge Valve Body	14007
9	Vacuum-Charge Valve Device	14005
10	Vacuum-Charge Valve Plug	14006

Ref. 5 - Compressor

Tension	Code
220/240V 50 Hz	23436
220/230V 60 Hz	23494
110/115V 60 Hz	23446

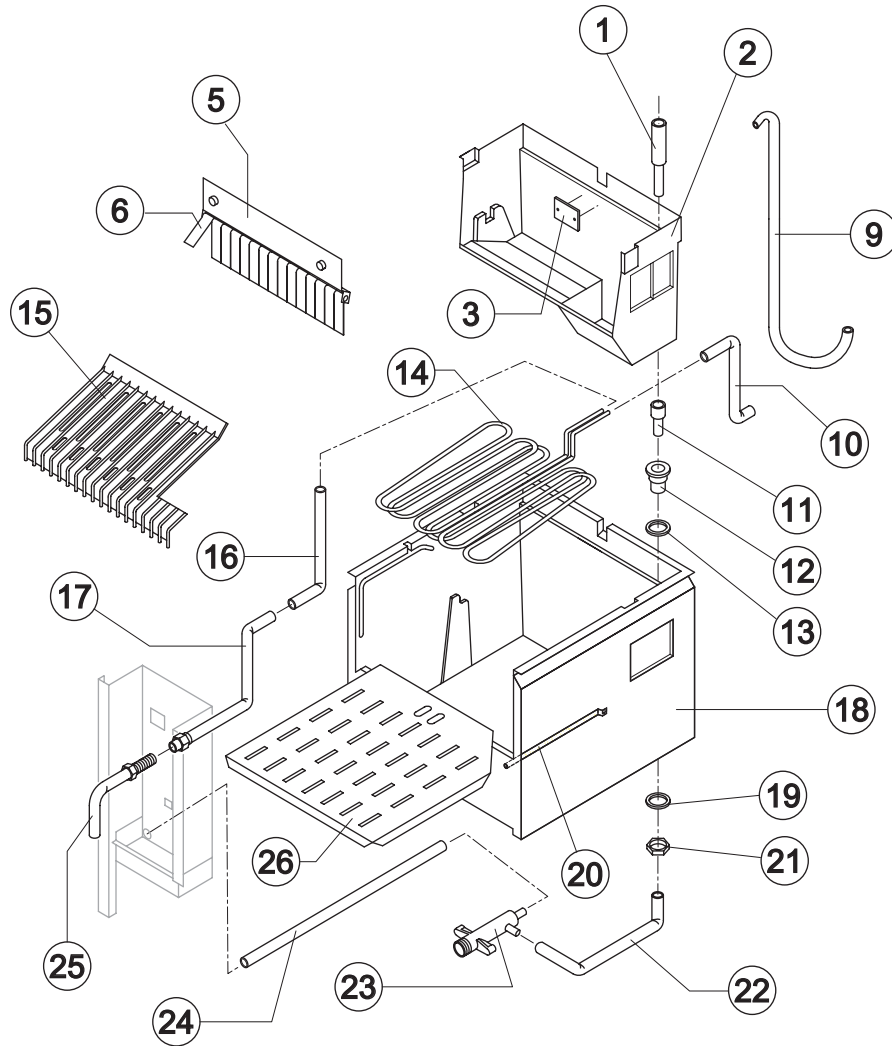

Ref.	Spare Description	Code
1	Overflow Pipe	13028
2	Inner Basin	10064
3	Slide Keep Plate	10142
5	Flags Support Assy	C22106
6	Flag	10005
9	Evaporator Feeding Pipe	13042
10	Inlet Valve-Coil Connection Pipe	13041
11	Overflow Pipe	13045
12	Plastic Nipple water Outlet	10007
13	Silicone Gasket	13006
14	Water Coil	14099
15	Ice Cubes Slide	10136
16	Coil-Faucet Connection Pipe	13040
17	Faucet Feeding Pipe	14102
18	Foamed Bin	11016/E
19	Semirigid Polyethylene Gasket	13007
20	Bulbe Thermostat Tube	20520
21	Bin Discharge Nut	10096
22	Bin Discharge Pipe	13044
23	Discharge Manifold	C10121
24	Dispenser Discharge Pipe	13043
25	Faucet	20195
26	Coil Covering Plate	22188

Rev. 3 - 20/10/2003

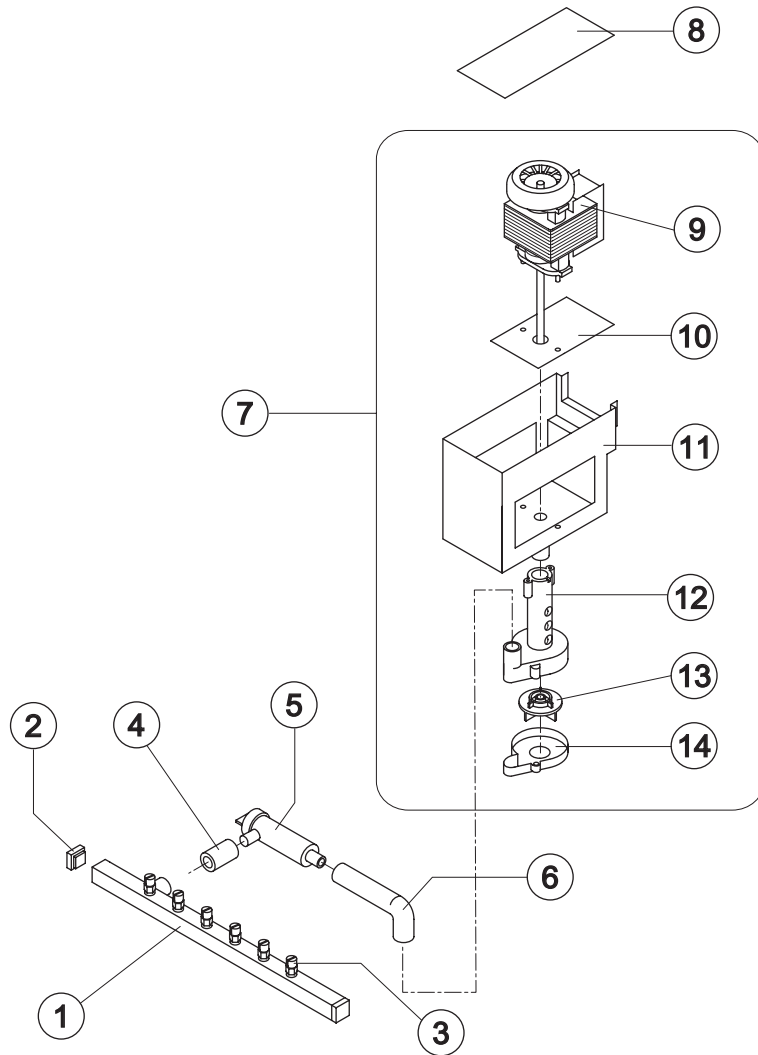

Ref.	Spare Description	Code
1	Sprayers Bar Assembly	C20147
2	Sprayers Bar Plug	10012
3	Sprayer	D20002
4	Filter-Sprayers Bar Connection Pipe	13056
5	Pump Filter	10139
6	Pump-Filter Connection Pipe	13055
7	Pump Assy	See Table
8	Pump Cover	22096
9	Pump Motor	See Table
10	Heat Dissipator	22430
11	Pump Motor Container	10073
12	Pump Body	10065
13	Pump Imeller	10066
14	Diffuser	10067

Ref. 7 - Pump Assy

Tension	Code
220/240V 50 Hz	C23076
220/230V 60 Hz	C23270
110/115V 60 Hz	C23271

Ref. 9 - Pump Motor

Tension	Code
220/240V 50 Hz	23073
220/230V 60 Hz	23187
110/115V 60 Hz	23188

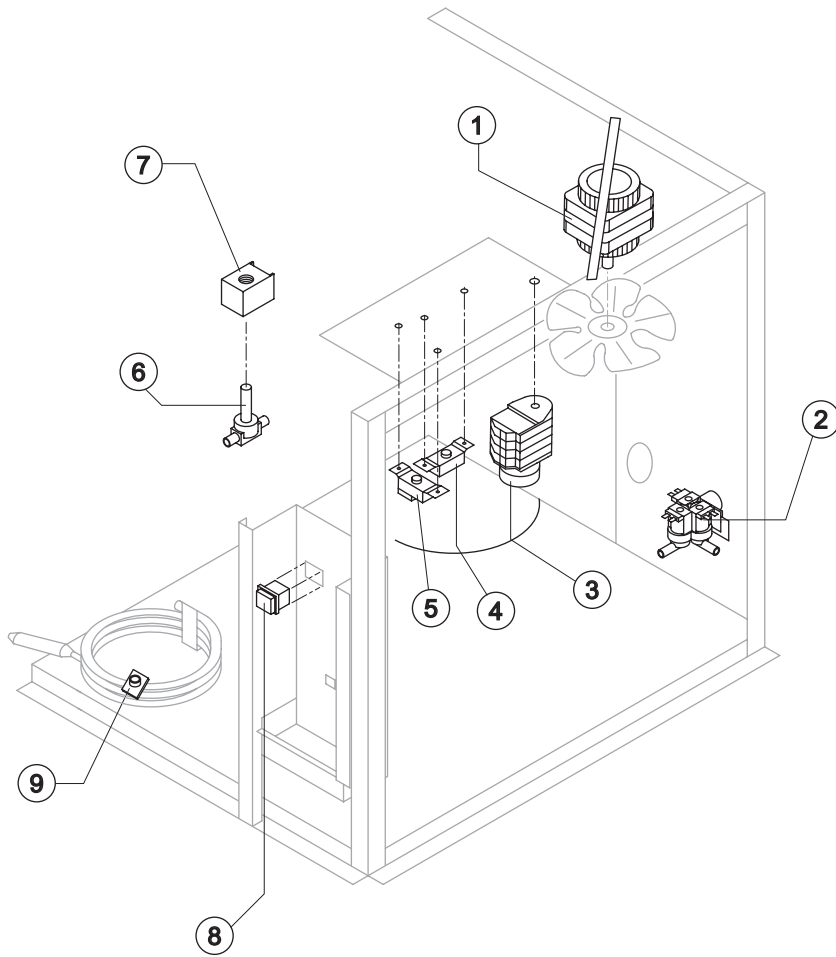

Ref.	Spare Description	Code
1	Fan Motor	See Table -
2	Inlet Watervale 3 Ways	See Table -
3	Timer	See Table -
4	Bin Thermostat	23005
5	Evaporator Thermostat	23591
6	Hot Gas Valve Body	20410
7	Hot Gas Coil	See Table -
8	Green Light Switch	23327
9	Safety Thermostat	C23114

Ref. 1 - Fan Motor

Tension	Code
220/240V 50 Hz	23029
220/230V 60 Hz	23029
110/115V 60 Hz	23683

Ref. 2 - Inlet Watervale 3Ways

Tension	Code
220/240V 50 Hz	23144
220/230V 60 Hz	23144
110/115V 60 Hz	23269

Ref. 3 - Timer

Tension	Code
220/240V 50 Hz	23247
220/230V 60 Hz	23247
110/115V 60 Hz	23258

Ref. 7 - Hot Gas Coil

Tension	Code
220/240V 50 Hz	23091
220/230V 60 Hz	23091
110/115V 60 Hz	23256