

FUNDADA EN 1878
MASBAGA
GRANDES COCINAS

EURAST

macfrin

TOLERANCIAS GENERALES: ±0.1 mm

 COOKING SYSTEMS,SL	FAMILIA: BAR 2009		DATA: 06/05/10
	MODELO: 4417		
DENOMINACION: CREPERA 2 PL.GAS	ESCALA: 1/8	MATERIAL: INOX	CODIGO: 4417

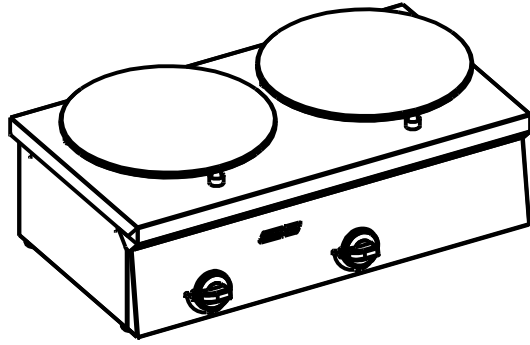

QT	COD	DESCRIPCION
4	1014	REMACHE ROSCADO M-10
1	3057	TETINA 1/2"
1	440294	SOPORTE IZQ. BATERÍA BAR
1	440426	ENVOLVENTE BAR 800
1	440439	FRONTAL MANDOS PL.800
1	440476	SOPORTE BATERÍA CORTA
1	441701	SOBRE CREPERA 2 PL.GAS
1	441914	REFUERZO SOBRE CREPERA 800
2	340173PM	CONJUNTO MANDO A GAS
1	440385PC	BATERIA COMP.BAR 600
6	440389P	CENTRADOR PLANCHA
2	441601P	PLACA CREPERA D.380 PAVONADA
6	506189P	DISTANCIADOR PASAPLATOS
1	C4500019	ESPATULA CREPERA
2	C5811019	TERMOPAR M8 C/ROSCADA L.320
4	C5811029	TUERCA TERMOPAR M8
2	C5815599M	CONJ.QUEMADOR ULTRA R.
2	C5816299M	CONJUNTO GRIFO EJE CORTO
4	C6260549	PATA PA M-10X30 BASE D.30
2	T08030	TUBO AL D.8 L.300

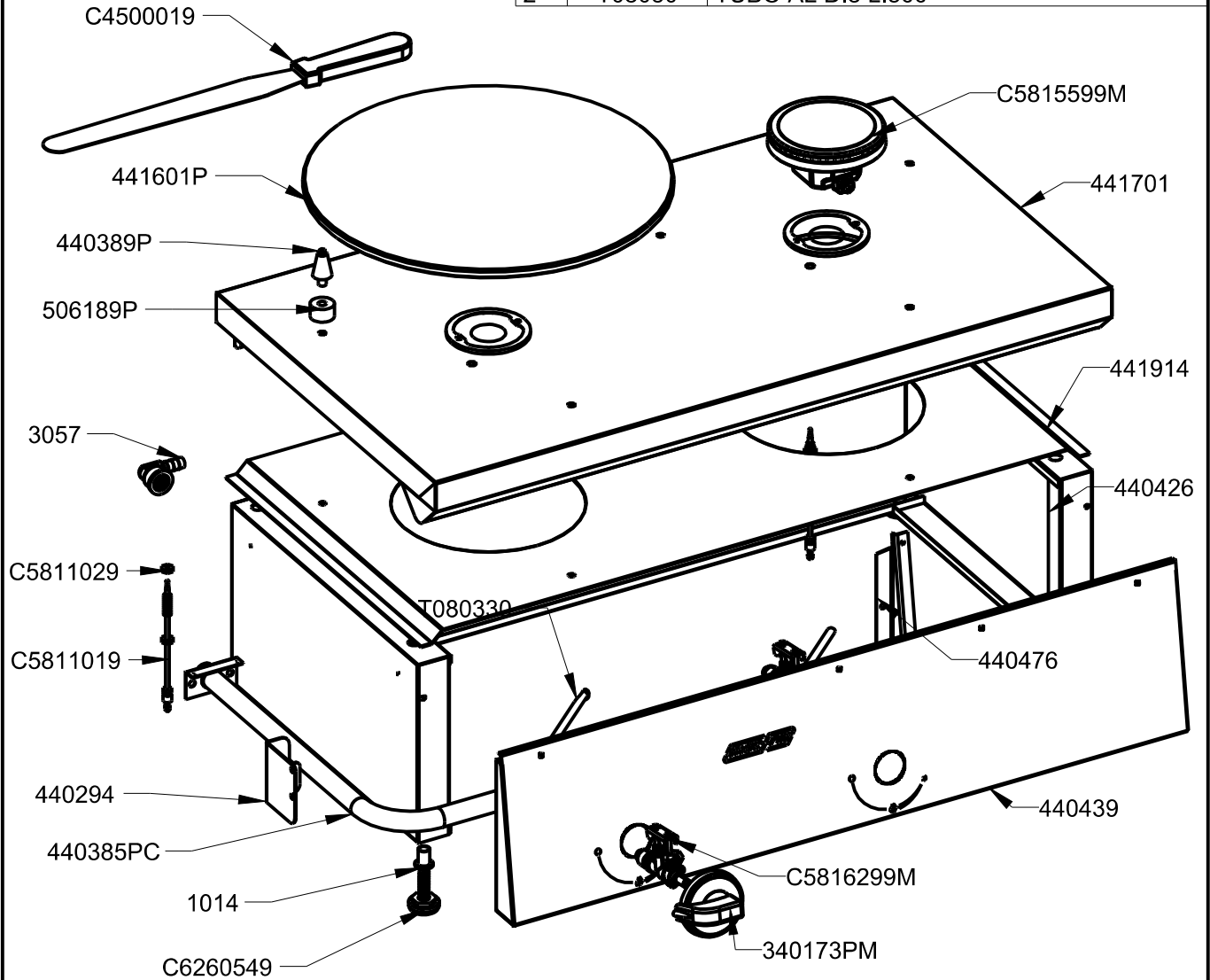

FUNDADA EN 1978
MASBAGA
GRANDES COCINAS

EURAST

macfrin

TOLERANCIAS GENERALES: ±0.1 mm

macfrin group
COOKING SYSTEMS,SL

FAMILIA: BAR 2009

DATA:
06/05/10

MODELO: 4417

DENOMINACION:
CREPERA 2 PL.GAS

ESCALA:
1/6

MATERIAL:
INOX

CODIGO:
4417



926/MA/11/05



QT	COD	DESCRIPCION	FAB.	MATERIAL	DATA
2	330294	PLETINA BASE BATERÍA	SÍ	FE 1.5	03/11/08
1	440294	SOPORTE IZQ. BATERÍA BAR	SÍ	GALVA 1.5	03/03/10
1	440426	ENVOLVENTE BAR 800	SÍ	INOFER 0.8	06/05/10
1	440439	FRONTAL MANDOS PL.800	SÍ	INOFER 0.8	10/02/10
1	440476	SOPORTE BATERÍA CORTA	SÍ	GALVA 1.5	07/04/10
1	441701	SOBRE CREPERA 2 PL.GAS	SÍ	INOFER 0.8	06/05/10
1	441914	REFUERZO SOBRE CREPERA 800	SÍ	GALVA 1.5	06/05/10
4	1014	REMACHE ROSCADO M-10	NO	ZN	17/12/09
1	3057	TETINA 1/2"	NO	LATON	01/01/01
2	31691	BRIDA 1/2" SABAF	NO	FE ZN	13/02/09
2	340172P	ENVELLECEDOR MANDO GAS/ELECT.	NO	ABS	10/12/07
2	340173P	MANDO COCINA GAS 2008	NO	BAQUELITA	10/12/07
2	340173PM	CONJUNTO MANDO A GAS	NO	BAQUELITA	10/12/07
1	440385P	BATERIA BAR 600	NO	FE 1/2"	01/03/10
1	440385PC	BATERIA COMP.BAR 600	NO	FE ZINCADO	01/03/10
6	440389P	CENTRADOR PLANCHA	NO	FE CROMADO	08/02/10
2	441601P	PLACA CREPERA D.380 PAVONADA	NO	FE 10	28/04/10
6	506189P	DISTANCIADOR PASAPLATOS	NO	INOX	14/10/08
4	C1061243	TORNILLO M-4X25 DIN933 ZN	NO	FE ZN	12/02/09
4	C1063249	TORNILLO M-4X6 DIN 7985 ZN	NO	FE ZN	01/01/08
1	C4500019	ESPATULA CREPERA	NO	INOX	06/05/10
2	C5811019	TERMOPAR M8 C/ROSCADA L.320	NO	CU	09/02/09
4	C5811029	TUERCA TERMOPAR M8	NO	CU	01/01/08
4	C5815559	BICONO D.8 SABAF	NO	LATON	13/02/09
2	C5815569	TUERCA 1/4" D.8 SABAF	NO	FE ZN	13/02/09
2	C5815579	ANILLO QUEMADOR ULTRA R.	NO	LATON	09/09/09
2	C5815589	TAPA QUEMADOR ULTRA R.	NO	FUNDICION	09/09/09
2	C5815599	SOPORTE QUEMADOR ULTRA R.	NO	ALUMINIO	09/09/09
2	C5815599M	CONJ.QUEMADOR ULTRA R.	NO	ALUMINIO	09/09/09
2	C5815609	COPA QUEMADOR ULTRA R.	NO	ALUMINIO	09/09/09
2	C5815619	TUERCA TUBO QUEM.ULTRA	NO	FE ZN	09/09/09
2	C5815629	INYECTOR GN D=1.67 M-6X0.75	NO	LATON	09/09/09
2	C5815639	INYECTOR GLP D=1.10 M-6X0.75	NO	LATON	09/09/09
2	C5816299	GRIFO PLANCHA BAR	NO	LATON	09/09/09
2	C5816299M	CONJUNTO GRIFO EJE CORTO	NO	LATON	09/09/09
4	C6260549	PATA PA M-10X30 BASE D.30	NO	PA NEGRA	15/04/10
2	T08030	TUBO AL D.8 L.300	NO	AL 99.7%	02/06/09



TOLERANCIAS GENERALES: ±0.1 mm



FAMILIA: BAR 2009

DATA:
06/05/10

MODELO: 4417

DENOMINACION:
CREPERA 2 PL.GAS

ESCALA:
1/6

MATERIAL:
INOX

CODIGO:
4417

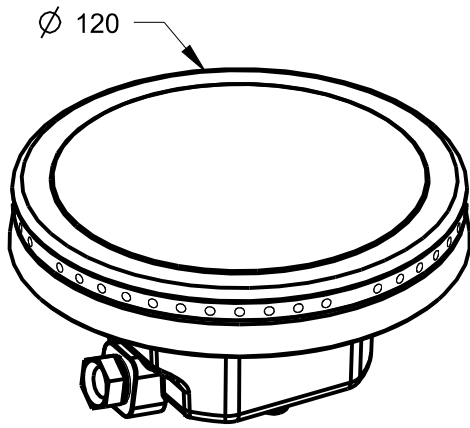

QT	COD	DESCRIPCION
2	C1063249	TORNILLO M-4X6 DIN 7985 ZN
1	C5815559	BICONO D.8 SABAF
1	C5815579	ANILLO QUEMADOR ULTRA R.
1	C5815589	TAPA QUEMADOR ULTRA R.
1	C5815599	SOPORTE QUEMADOR ULTRA R.
1	C5815609	COPA QUEMADOR ULTRA R.
1	C5815619	TUERCA TUBO QUEM.ULTRA
1	C5815629	INYECTOR GN D=1.67 M-6X0.75
1	C5815639	INYECTOR GLP D=1.10 M-6X0.75

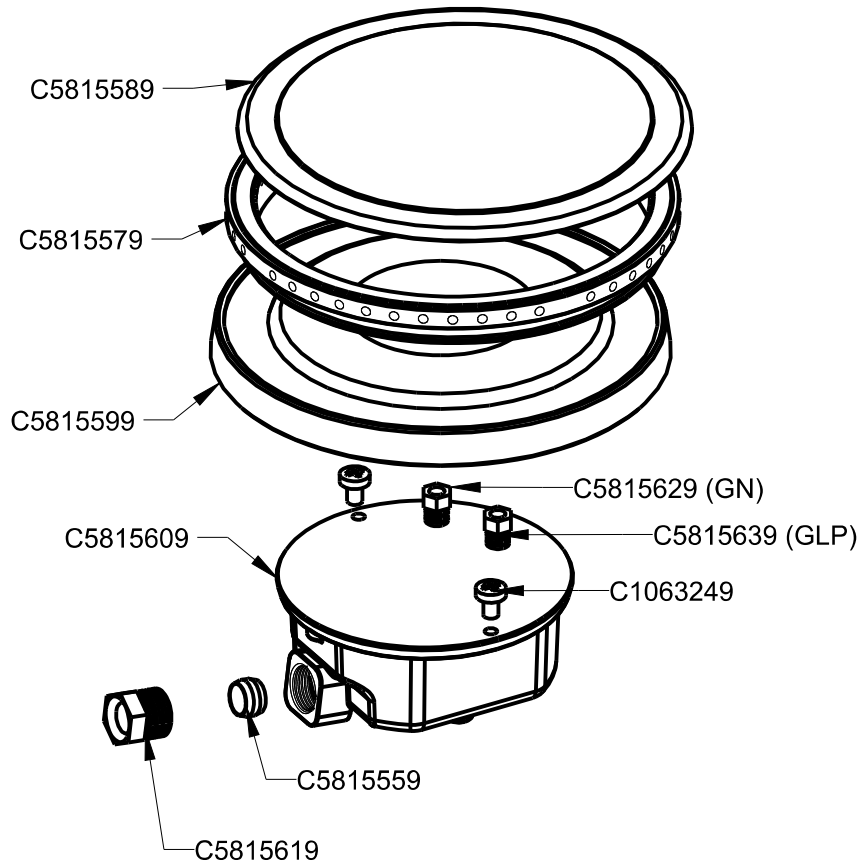



4785/ER/11/05



QT	COD	DESCRIPCION
1	31691	BRIDA 1/2" SABAF
2	C1061243	TORNILLO M-4X25 DIN933 ZN
1	C5815559	BICONO D.8 SABAF
1	C5815569	TUERCA 1/4" D.8 SABAF
1	C5816299	GRIFO PLANCHA BAR

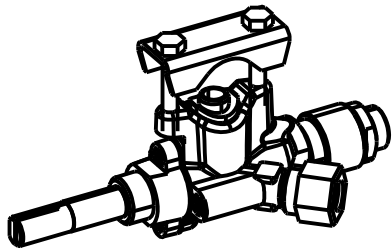

ESCALA 1/2

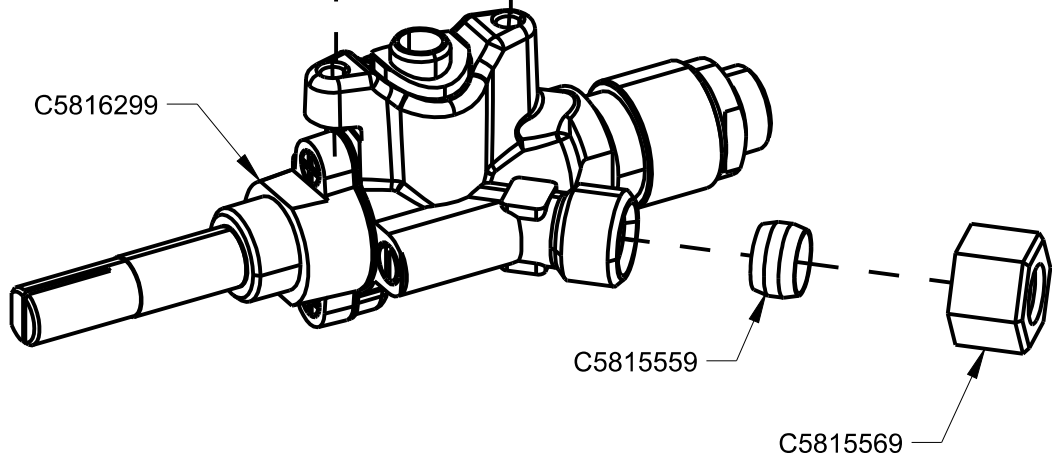
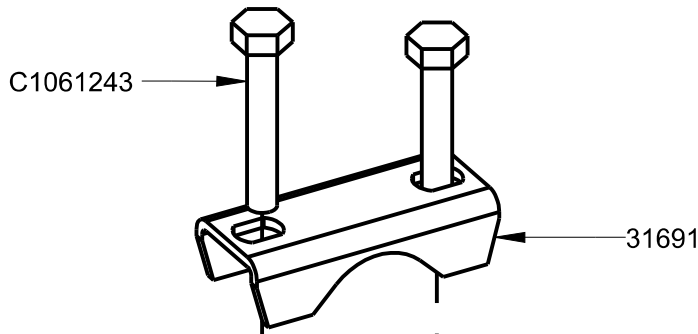
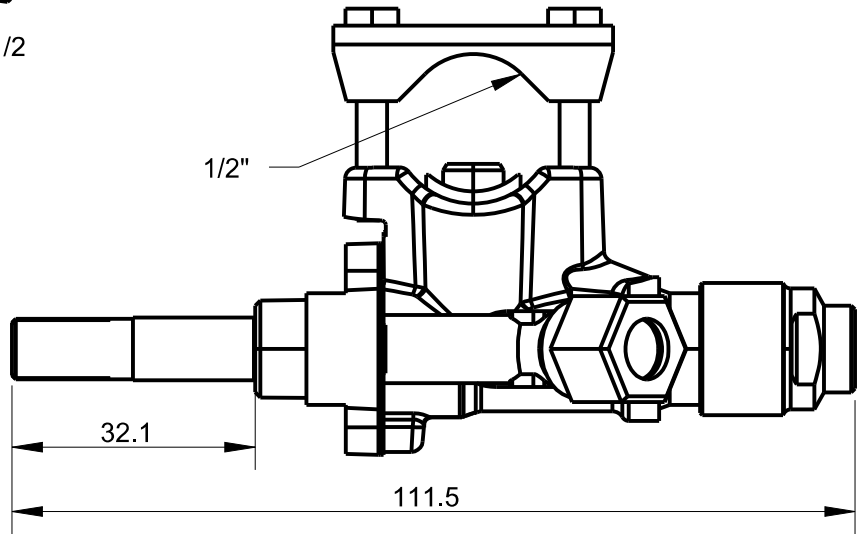

TOLERANCIAS GENERALES: ±0.1 mm



COOKING SYSTEMS,SL

FAMILIA: BAR 2009

DATA: 09/09/09

MODELO: 4412

DENOMINACION:
CONJUNTO GRIFO EJE CORTO

ESCALA:
1/1

MATERIAL:
LATON

CODIGO:
C5816299M