

CME506R, CME656R & CME806R Service Parts

This parts list contains the service part numbers for 3 basic Electrical Components Common to All Machines models, plus 4 different electrical configurations. It contains service parts for all series machines. The series differences include:

- A - first production
- B - not used
- C - New front panel and side panels
- D - New top panel and PTCR
- E - New side panels and CME506R expansion valve change
- Inlet water valve
- System controller
- Water sensor
- Discharge line sensor
- Bin controls
- Water level sensor
- Hi pressure cut out

The complete model number will be needed to identify the correct part.

Unique parts include: cabinet, electrical and refrigeration.

Electrical Codes are located at the end of the model number (voltage/hertz/phase):

- -1 is 115/60/1
- -32 is 208-230/60/1
- -3 is 208-230/60/3
- -6 is 250/50/1

Unique Electrical Components

- Compressor and related starting components
- Contactor (single / three phase)
- Fan motor
- Water pump
- Transformer
- Hot gas valve

Table of Contents

Cabinet	page 2
Interior Structure and Controls	page 3
CME506 Refrigeration	page 4
CME506 E Series Refrigeration	page 5
CME656 Refrigeration	page 6
CME806 Refrigeration	page 7
Receiver	page 8
Water System Components	page 9
Compressors and Electrical Components	page 10
HTB555 Ice Storage Bin	page 11
Remote Condenser	page 12
Wiring Diagrams	page 13

CME506R, CME656R & CME806R Service Parts

Cabinet

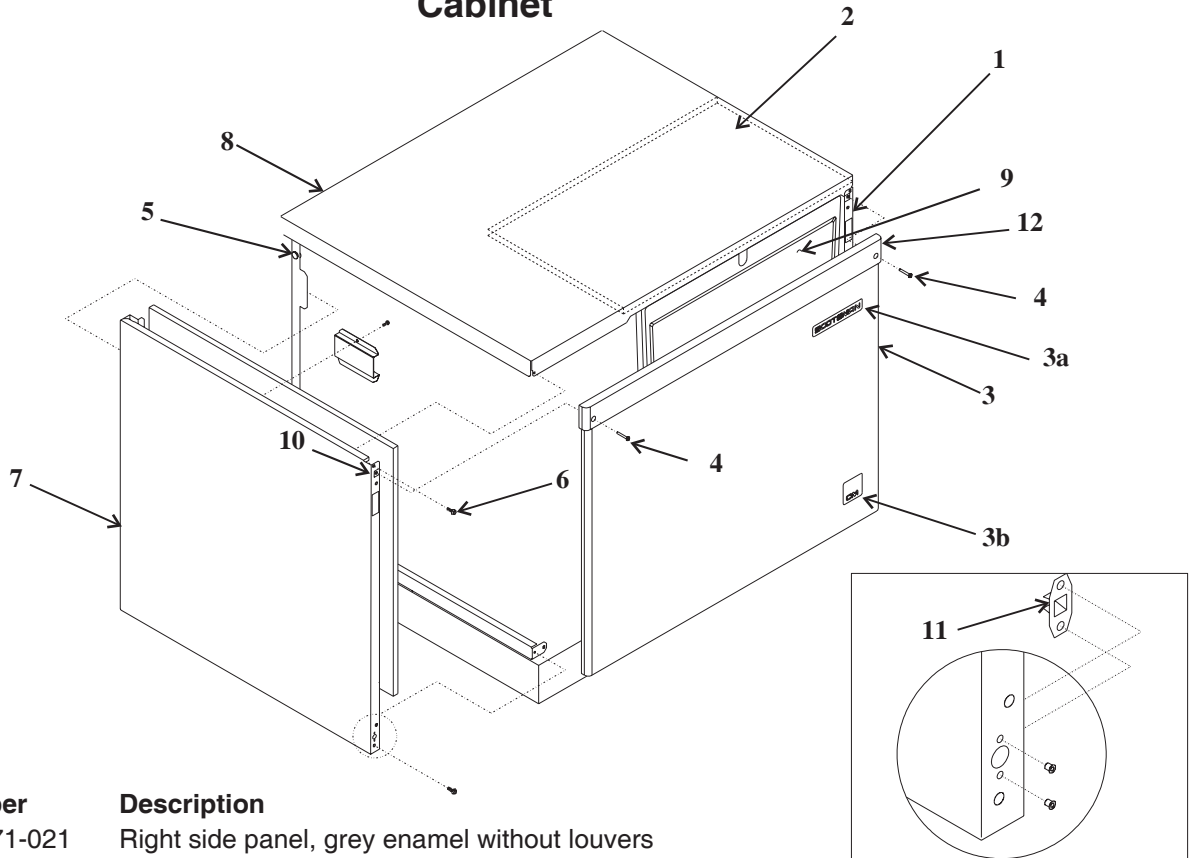

Item Number	Part Number	Description		
1	A37071-021	Right side panel, grey enamel without louvers		
	A37071-022	A - D series right side panel, stainless steel without louvers		
	A38126-021	E Series right side panel		
2	02-3659-01	Top insulation		
3	02-3797-21	C series Front panel kit, gray plastic , includes trim strip & emblems		
	03-1733-01	Strike (for C model panel, SS and plastic)		
	A37167-001	Front panel kit, gray plastic, includes item 10a (for A series)		
	A37488-021	C or higher series Front panel kit, stainless steel , includes trim strip & emblems		
	A35964-002	Front panel kit, stainless steel (for A models)		
3a	15-0808-01	Emblem for ss panel (Scotsman); 03-0271-00 is the speed nut for emblem		
3b	15-0792-02	Emblem for C to E series front panel, (CM ³)		
4	03-1735-01	Screw for trim strip (for C or D or E series)		
	03-1404-12	Sheet metal screw for plastic front panel (for A series)		
	03-1419-22	Sheet metal screw for ss front panel		
5	02-1875-03	Panel bumper/hole plug		
6	03-1531-01	Sheet metal screw for A - C series		
	03-1403-19	Machine screw for D series		
7	A37070-021	Left side panel, grey enamel without louvers A - D series only		
	A37070-022	Left side panel, stainless steel without louvers A - D series only		
	A38127-021	E Series Left side panel		
8	A35965-001	Top panel, grey enamel, order item 2 also		
	A35965-002	Top panel, stainless steel, order item 2 also		
	02-3822-21	Top panel, plastic, original with D series, fits all and includes item 2		
	02-3663-01	Evaporator cover, use began Feb. 1997. For A and B series		
9a	02-3796-01	Evap cover insulation for above cover		
	02-3663-20	Evaporator cover w/ins for C - higher series		
	02-3663-01	Evaporator cover, use began Feb. 1997. For A and B series		
10	03-1423-06	Speed nut for panel screws		
11	03-1733-02	Catch		
		12	02-3794-31	Trim strip.
			03-1731-02	Push nut for trim strip

CME506R, CME656R & CME806R Service Parts

Interior Structure & Controls

Note: Item 25 mounts to Item 1.
Item 1 must have rectangular tabs. All units after 9/96 were mfg. with rectangular tabs.

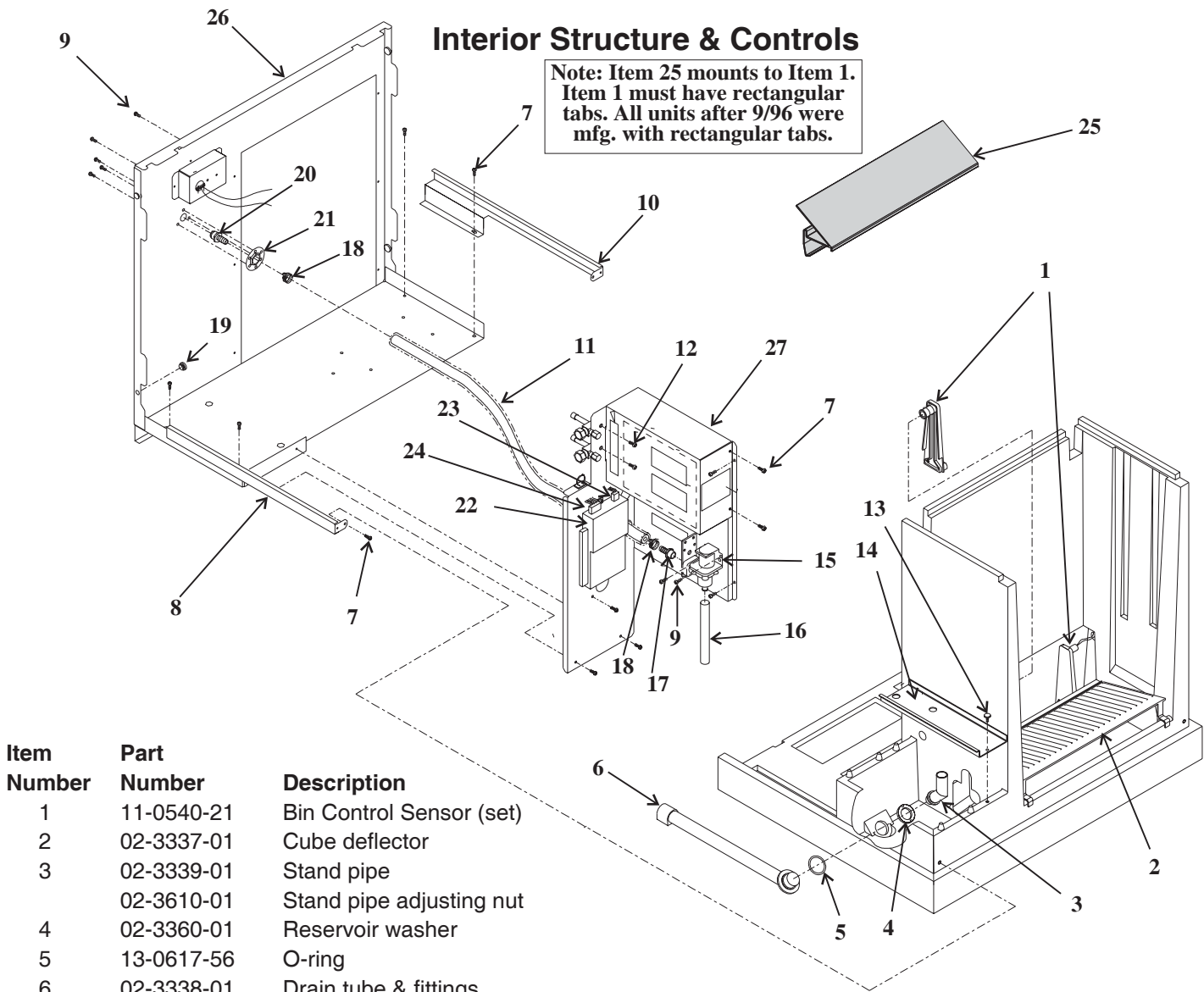

Item Number	Part Number	Description
1	11-0540-21	Bin Control Sensor (set)
2	02-3337-01	Cube deflector
3	02-3339-01	Stand pipe
	02-3610-01	Stand pipe adjusting nut
4	02-3360-01	Reservoir washer
5	13-0617-56	O-ring
6	02-3338-01	Drain tube & fittings
7	03-1404-18	Screw
8	A36298-001	Left side channel
9	03-1404-07	Screw
10	A36297-001	Right side channel
11	13-0906-01	Plastic Inlet water tube, 21"
		not used after Sept. 1996
12	03-1645-01	Screw
13	03-1691-01	Nylon screw
14	02-3340-01	Reservoir cover
15	12-2548-01	Inlet water valve
16	13-0674-02	Tubing, 9" req., order 1 unit
17	obsolete	Water inlet fitting for hose
	16-1020-01	Water fitting for copper
18	obsolete	Clamp for hose
19	13-0903-01	Bumper for side panels
20	16-0997-01	Inlet water fitting for hose
	16-1019-01	Inlet water fitting for copper

Item Number	Part Number	Description
21	16-0701-07	Mounting flange
22	12-2838-23	System controller, fits all
23	12-2541-21	Hi Voltage harness A - C
	12-2785-01	Hi voltage harness - D series
24	12-2644-02	Lo voltage harness A - C
	12-2782-02	Lo voltage harness, D + series
25	02-3657-01	Cascading shield, use began 2/97.
26	A36460-001	Back panel assy
27	A35959-001	Hi voltage box cover

CME506R A - D Series Refrigeration System

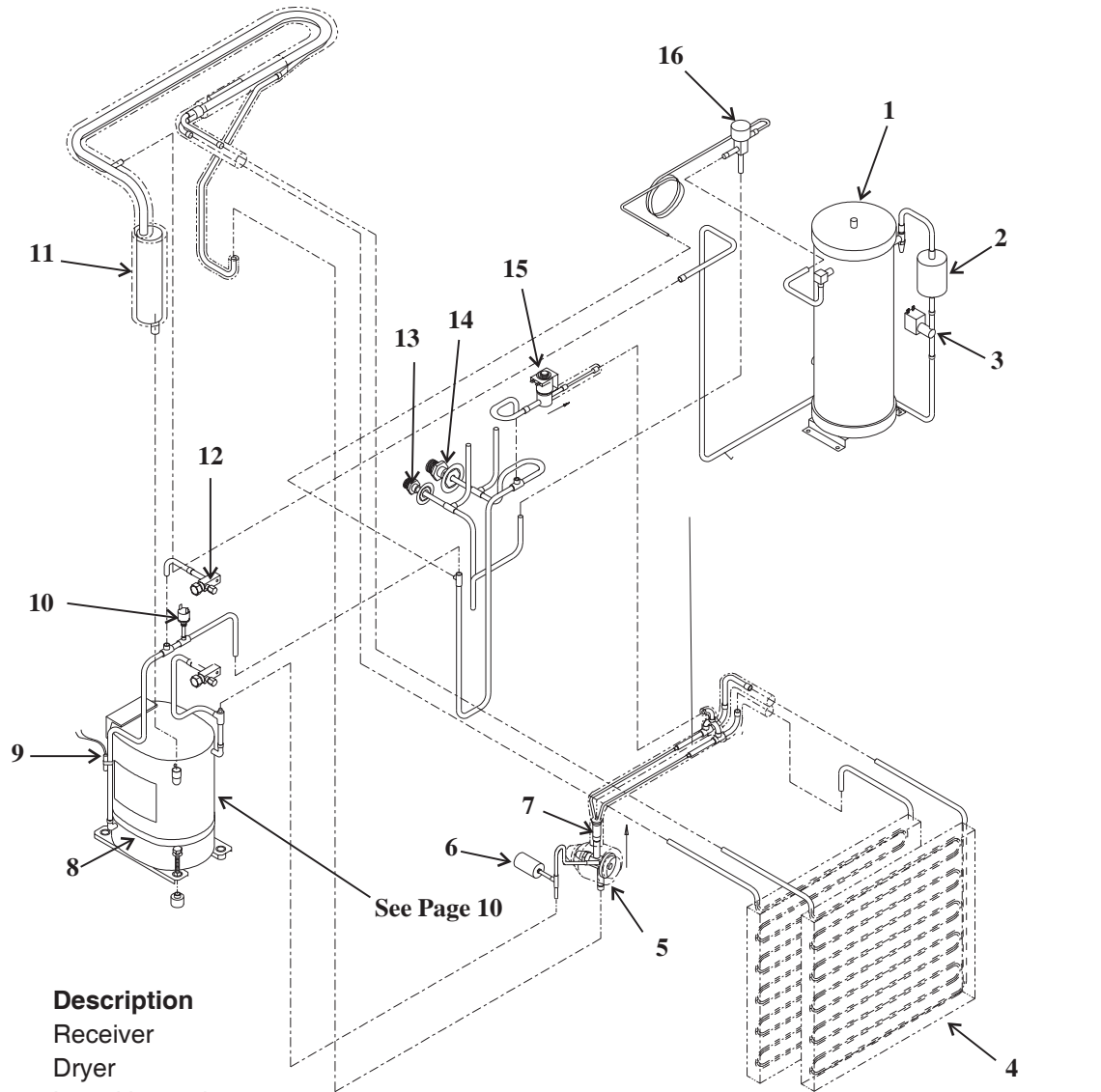

Item Number	Part Number	Description	
1	16-0761-01	Receiver	
2	02-3319-02	Dryer	
3	12-2471-23	Liquid line valve	
4	A36734-020	Evaporator	
5	16-1017-21	TXV	
	02-2920-01	Insulation for TXV	
6	11-0502-21	Pump down pressure switch	
7	16-0843-03	Distributor and tubes	
8	12-1868-01	Crankcase heater	
9	02-3410-21	Discharge line temperature sensor, includes water temp sensor & clip	
	03-1711-01	Sensor clip	
10	11-0501-22	Hi pressure cut out switch	
11	16-0778-21	Accumulator	
12	16-0832-20	Access valve	
	16-0832-03	Port cap	
	16-0832-02	Stem cap	
13	16-0850-03	Liquid line fitting	
14	16-0850-01	Discharge line fitting	
15	12-2471-22	Hot gas valve complete	
	12-2719-23	Hot gas valve coil	
	16	11-0422-24	Discharge pressure control valve
	17	16-1063-01	Hot gas valve strainer, not shown

CME506R E & Higher Series Refrigeration System

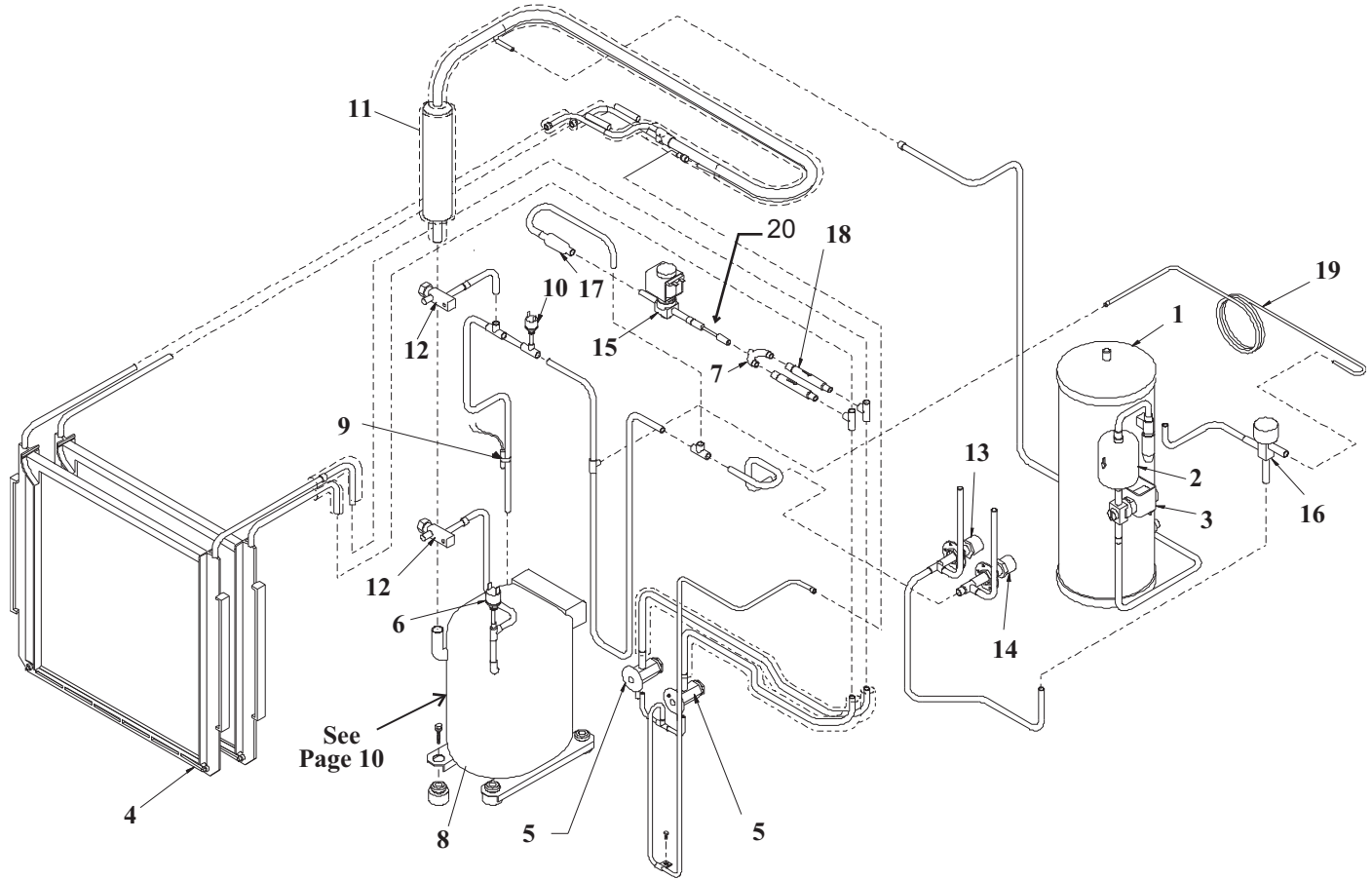

See Page 10

Item Number	Part Number	Description	Item Number	Part Number	Description
1	16-0761-01	Receiver	16	11-0422-24	Discharge pressure control valve
2	02-3319-02	Dryer	17	16-1063-01	Hot gas valve strainer
3	12-2471-23	Liquid line valve	18	16-1071-01	Check valve
4	A36734-020	Evaporator	19	A36427-001	By-pass tubing
5	16-1009-22	TXV - only for E series	20	16-1095-01	Restrictor
	02-3792-01	Insulation for TXV			
6	11-0502-21	Pump down pressure switch			
7	16-0776-01	Tee			
8	12-1868-01	Crankcase heater			
9	02-3410-21	Discharge line temperature sensor, includes water temp sensor & clip			
	03-1711-01	Sensor clip			
10	11-0501-22	Hi pressure cut out switch			
11	16-0778-21	Accumulator			
12	16-0832-20	Access valve			
	16-0832-03	Port cap			
	16-0832-02	Stem cap			
13	16-0850-03	Liquid line fitting			
14	16-0850-01	Discharge line fitting			
15	12-2471-22	Hot gas valve complete			
	12-2719-23	Hot gas valve coil			

CME506R, CME656R & CME806R Service Parts

Receiver

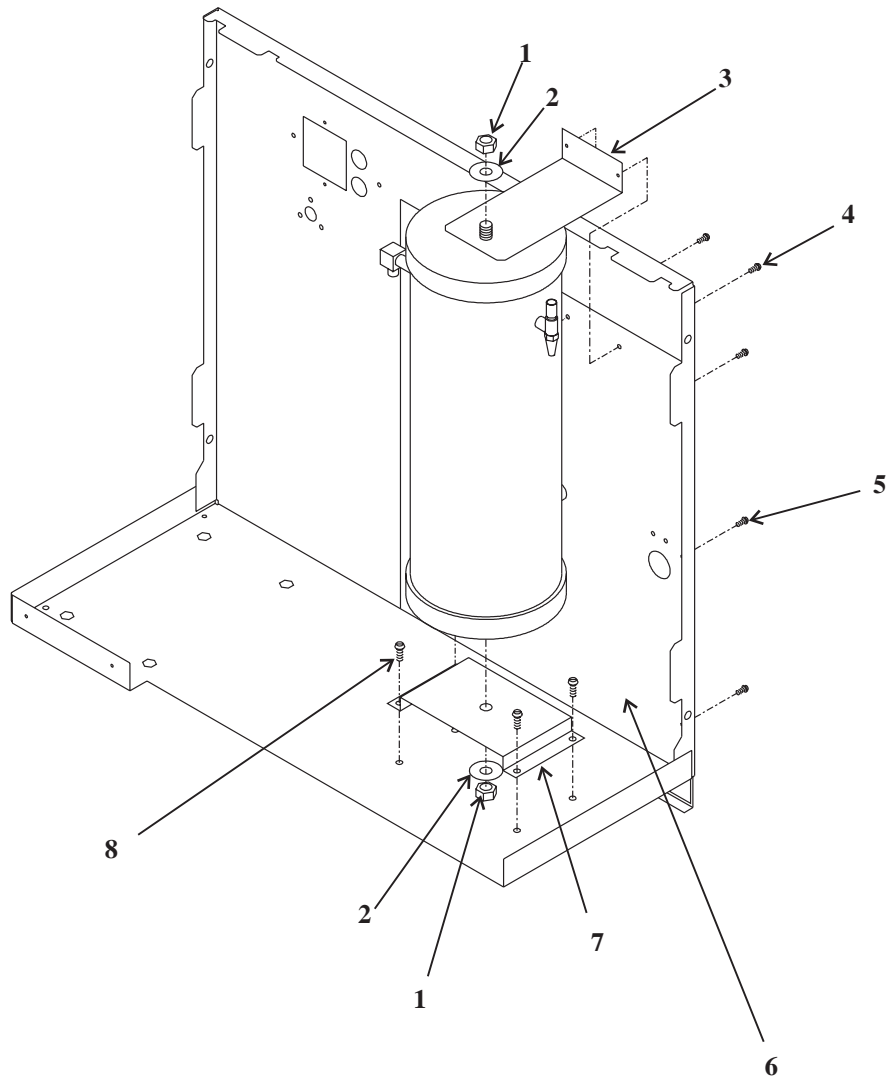

Item Number	Part Number	Description
1	03-1406-13	Nut
2	03-1410-06	Washer
3	A36454-001	Bracket
4	03-1638-03	Screw
5	03-1531-01	Screw
6	A36440-001	Back cover
7	A36021-001	Bracket
8	03-1645-01	Screw

CME506R, CME656R & CME806R Service Parts

Water System Components

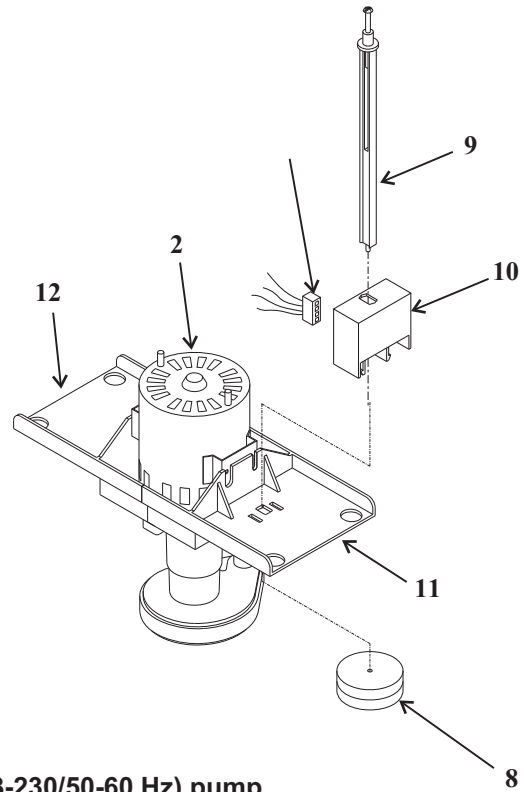
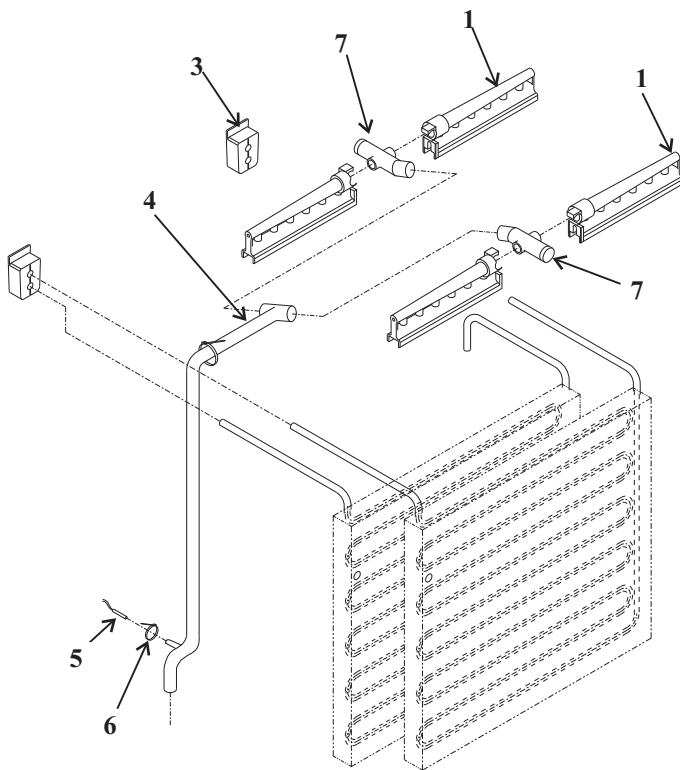

Item Number	Part Number	Description
1	02-2527-01	Water distributor
2	12-2586-27	CME506-1 pump (115/60 Hz)
	12-2586-23	CME656 or CME506-6 or CME806 (203-230/50-60 Hz) pump
3	13-0898-01	Tubing grommet
4	02-3336-01	Water distributor tube
5	02-3410-21	Water temperature sensor includes disch. temp. sensor
6	no number	Cable tie
7	02-3405-01	Inlet Tee
	13-0840-01	Rubber plug
8	02-3341-01	Float
9	02-3383-02	Float stem grey, non adjustable after 2/97
10	11-0539-51	Float sensor
11	02-3388-04	Front pump bracket for 12-2586 type pump
12	02-3388-05	Rear pump bracket for 12-2586 type pump
13	12-2506-01	Harness

CME506R, CME656R & CME806R Service Parts

Compressors and Electrical Components

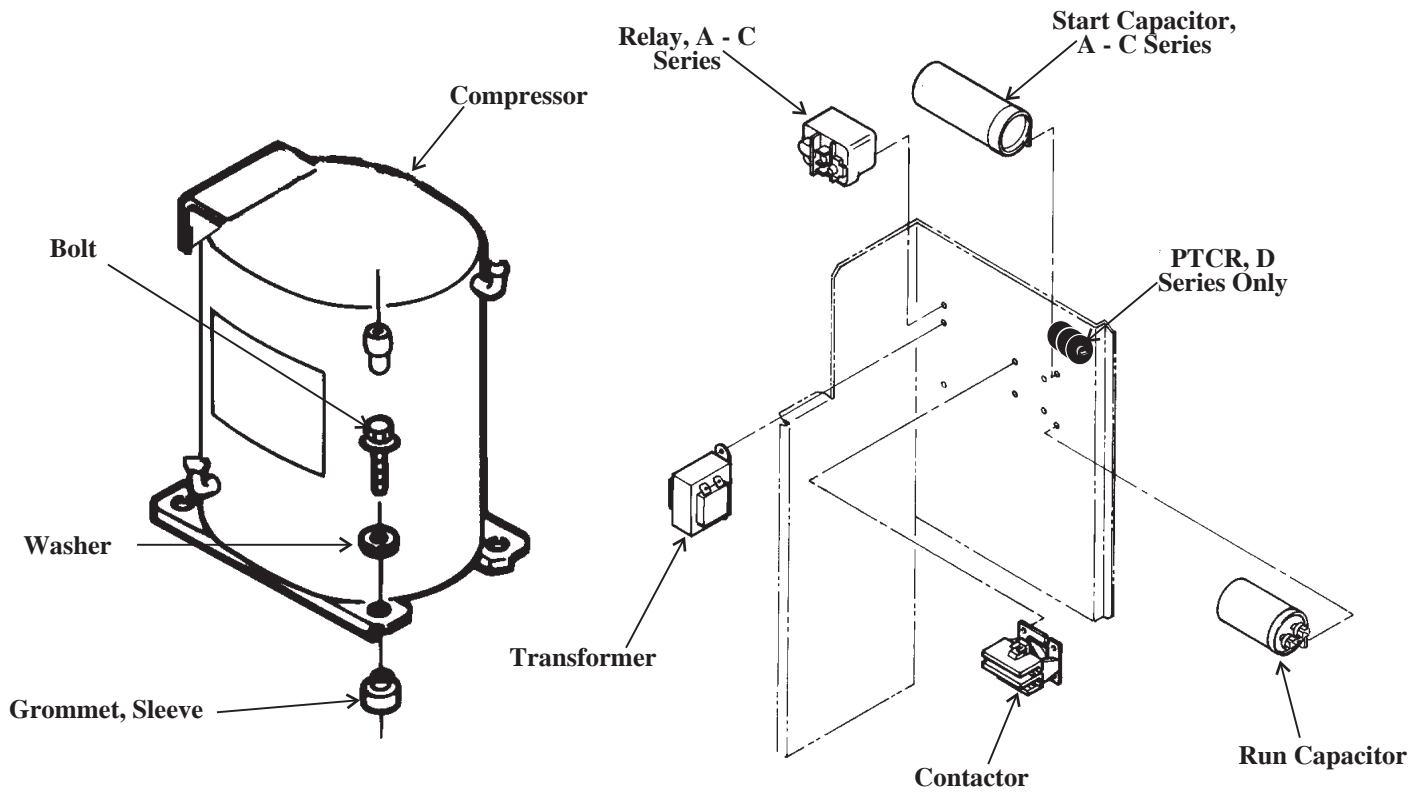

Model	CME506		CME656			CME806	
Voltage/Hz	115/60	250/50	208-230/60	208-230/60	250/50	208-230/60	230/50
Phase	Single	Single	Single	Three	Single	Single	Single
Compressor*	18-8721-21*	18-8721-22	18-8813-23*	18-8813-25	18-8813-27	18-8749-22*	18-8749-27
PTCR** D series	18-8835-01	18-8835-01	18-8835-01	18-8835-01	18-8835-01	18-8835-01	18-8835-01
Start Relay**	18-1903-50	18-1903-29	18-1903-33	not used	18-1903-29	18-1903-46	18-1903-33
Start Capacitor**	18-1901-03	18-1901-43	18-1901-15	not used	18-1901-52	18-1901-48	18-1901-48
Run Capacitor	18-1902-45	18-1902-30	18-1902-53	not used	18-1902-53	18-1902-55	18-1902-55
Overload	18-8711-50	18-8721-50	internal	internal	internal	internal	internal
Mounting Bolt	03-1405-20	03-1405-20	03-1405-20	03-1405-20	03-1405-20	03-1405-20	03-1405-20
Sleeve	18-2200-27	18-2200-27	18-2200-27	18-2200-27	18-2200-27	18-2200-27	18-2200-27
Washer	03-1407-07	03-1407-07	03-1407-07	03-1407-07	03-1407-07	03-1407-07	03-1407-07
Grommet	18-2200-28	18-2200-28	18-2200-28	18-2200-28	18-2200-28	18-2200-28	18-2200-28
Contactor	12-2469-01	12-2469-01	12-2469-01	12-2533-01	12-2469-01	12-2469-01	12-2469-01
Transformer	A37231-001	A37217-001	A37217-001	A37217-001	A37217-001	A37217-001	A37217-001

CME506R, CME656R & CME806R Service Parts

HTB555 Ice Storage Bin

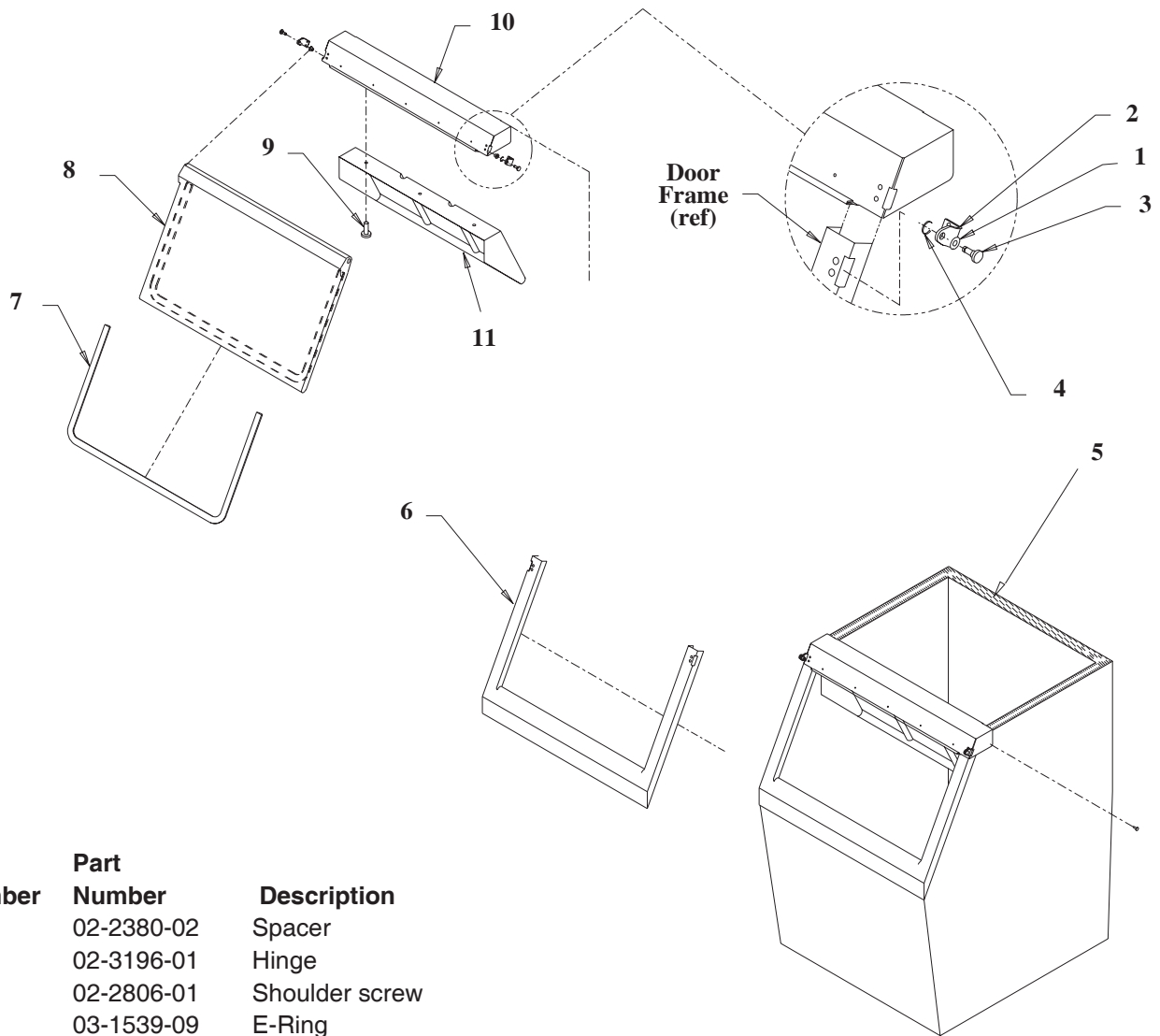

Item Number	Part Number	Description
1	02-2380-02	Spacer
2	02-3196-01	Hinge
3	02-2806-01	Shoulder screw
4	03-1539-09	E-Ring
5	19-0503-04	Gasket, order 9 units
6	02-3274-02	Door frame - Grey
7	13-0909-01	Door gasket, order 5 units
8	A36481-022	Door - Grey
9	03-0727-11	Thumb screw
10	A35637-001	Canopy
11	A37310001	Baffle
12	02-2809-02	Drain top
13	13-0617-09	O-Ring
14	02-3108-01	Drain bottom
Not shown	05-0586-01	Drain elbow
	02-0540-00	Scoop

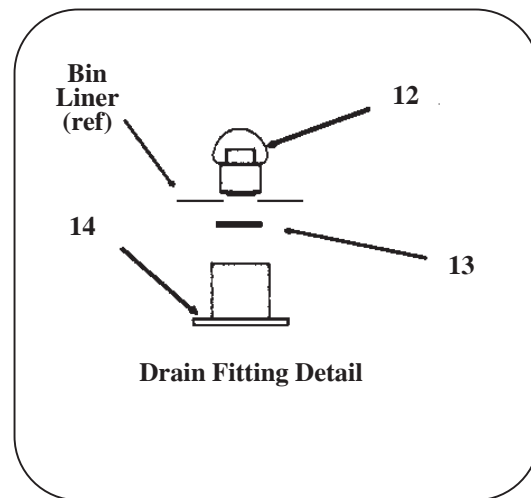

CME506R, CME656R & CME806R Service Parts

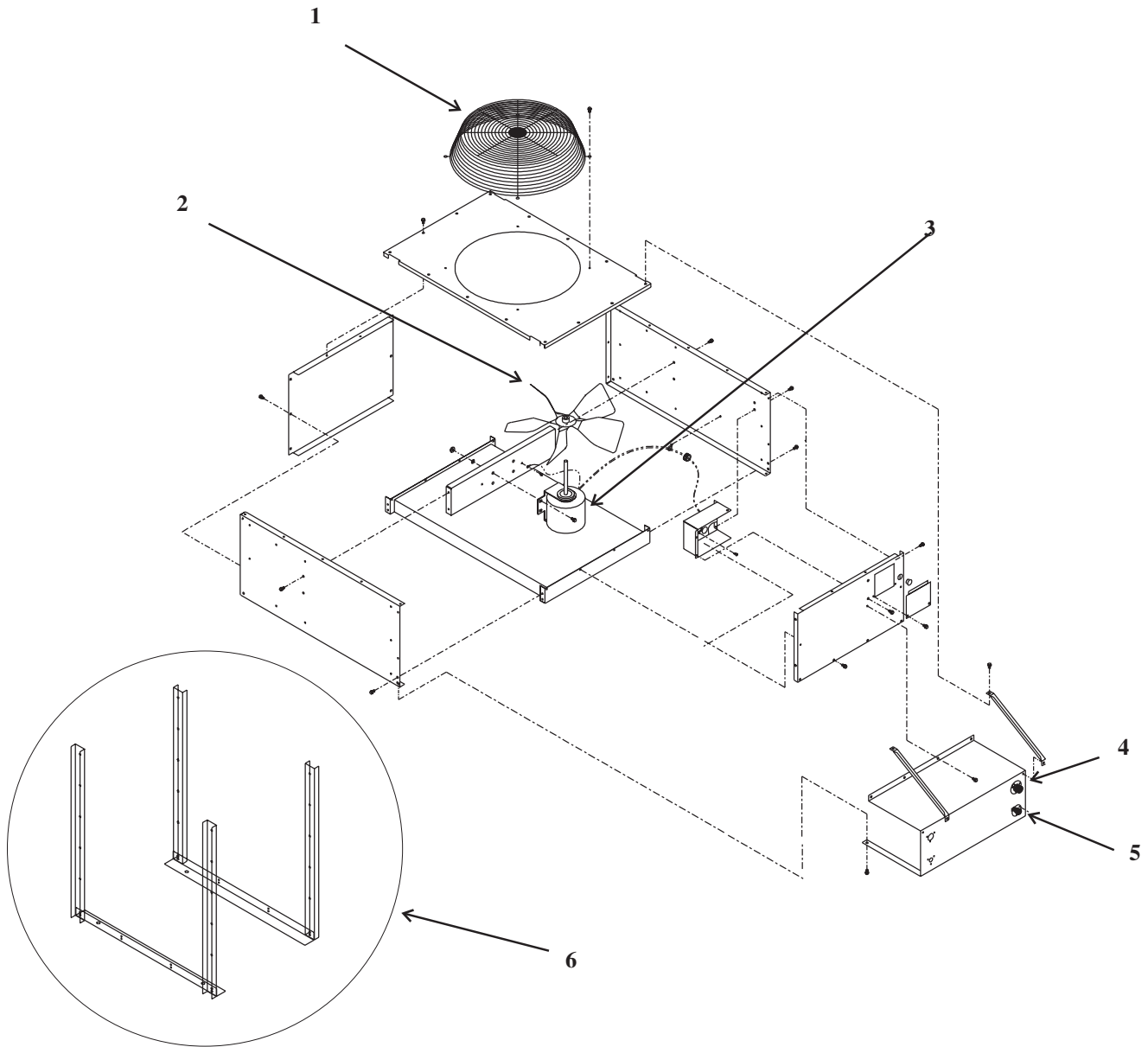

ITEM NUMBER	PART NUMBER	PART DESCRIPTION
1	02-3575-01	Fan guard
2	18-8800-01	Fan blade
3	18-8796-01	Fan motor ERC101
	18-8796-32	Fan motor ERC201, ERC402
4	16-0850-01	Quick connect, discharge
5	16-0850-03	Quick connect, liquid
6	A36990-001	Leg kit for ERC101, 201
	A36990-002	Leg kit for ERC402
Filters:		
	02-3231-03	Discharge line
	02-3231-02	Liquid line

CME506R, CME656R & CME806R Service Parts

D Series, Single Phase Schematic Diagram

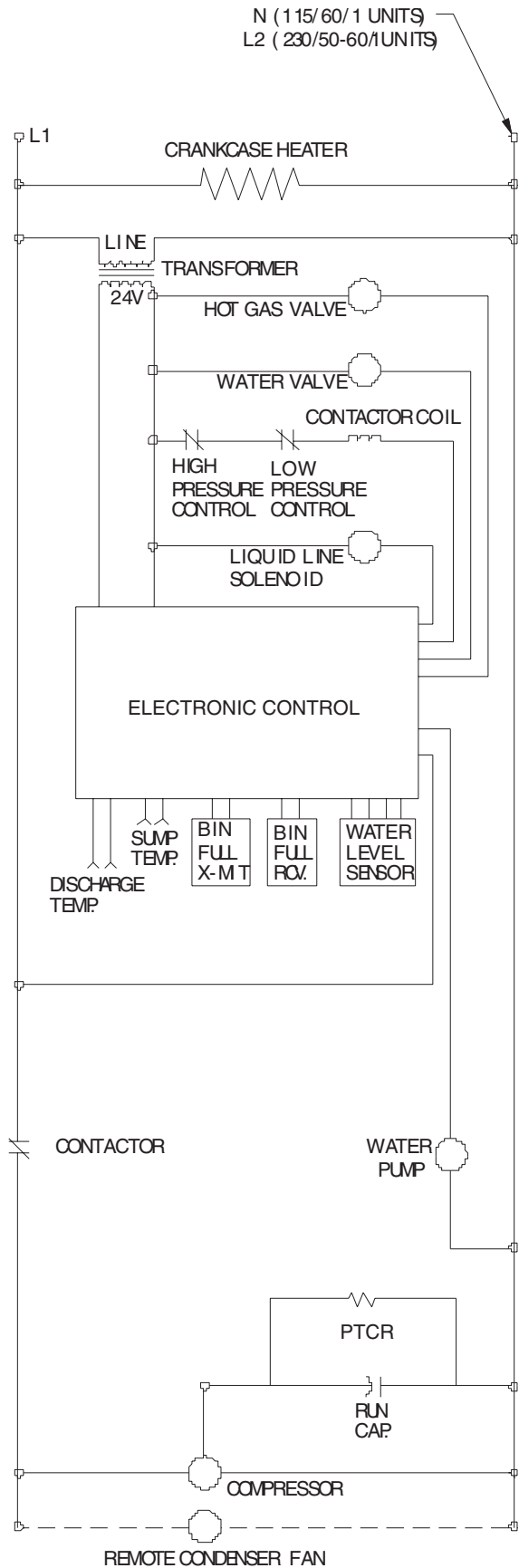

CME506R, CME656R & CME806R Service Parts

D Series, CME506R Wiring Diagram

17-2748-01

USE COPPER CONDUCTORS ONLY

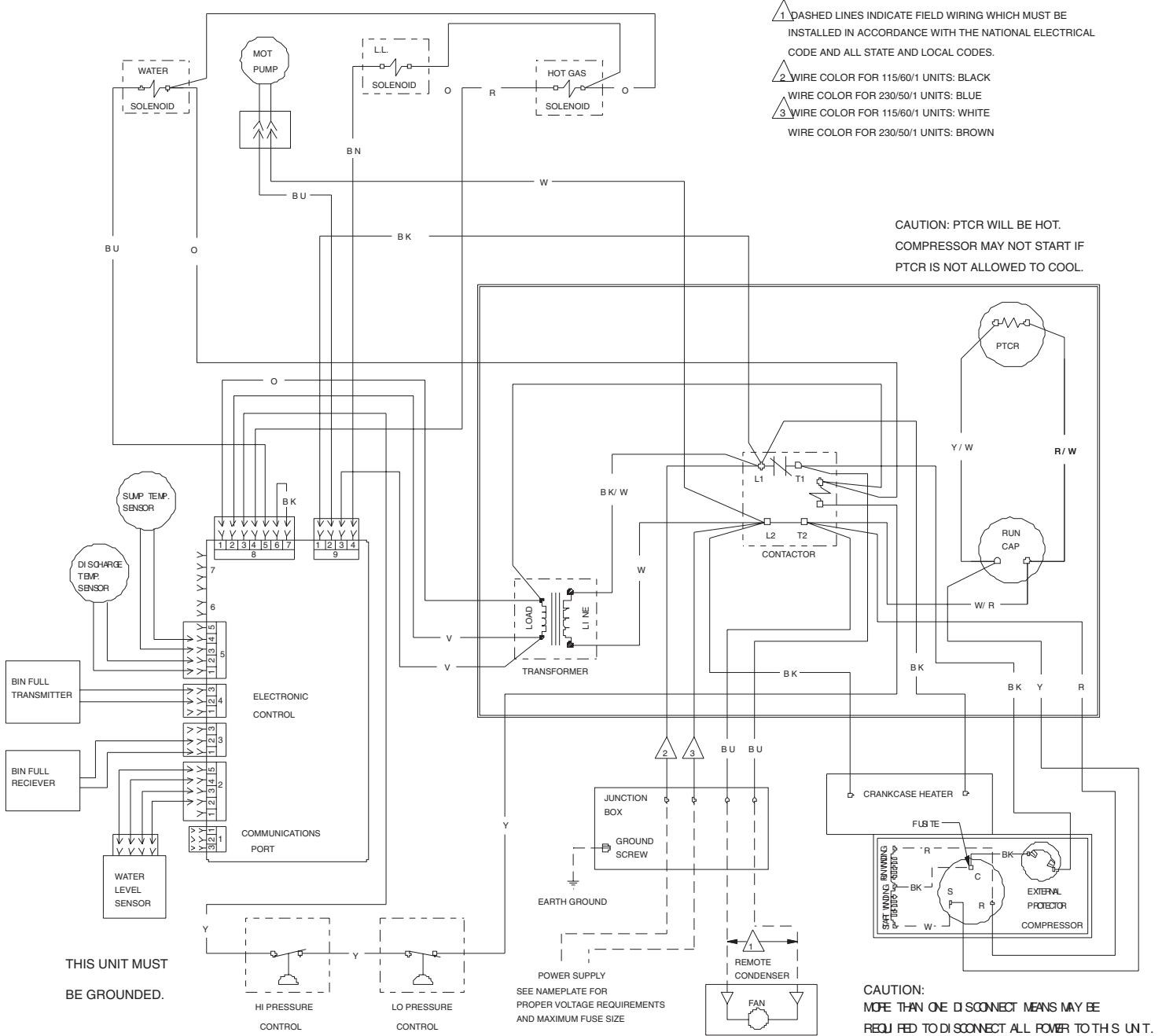

CME506R, CME656R & CME806R Service Parts

D Series, Three Phase Schematic Diagram

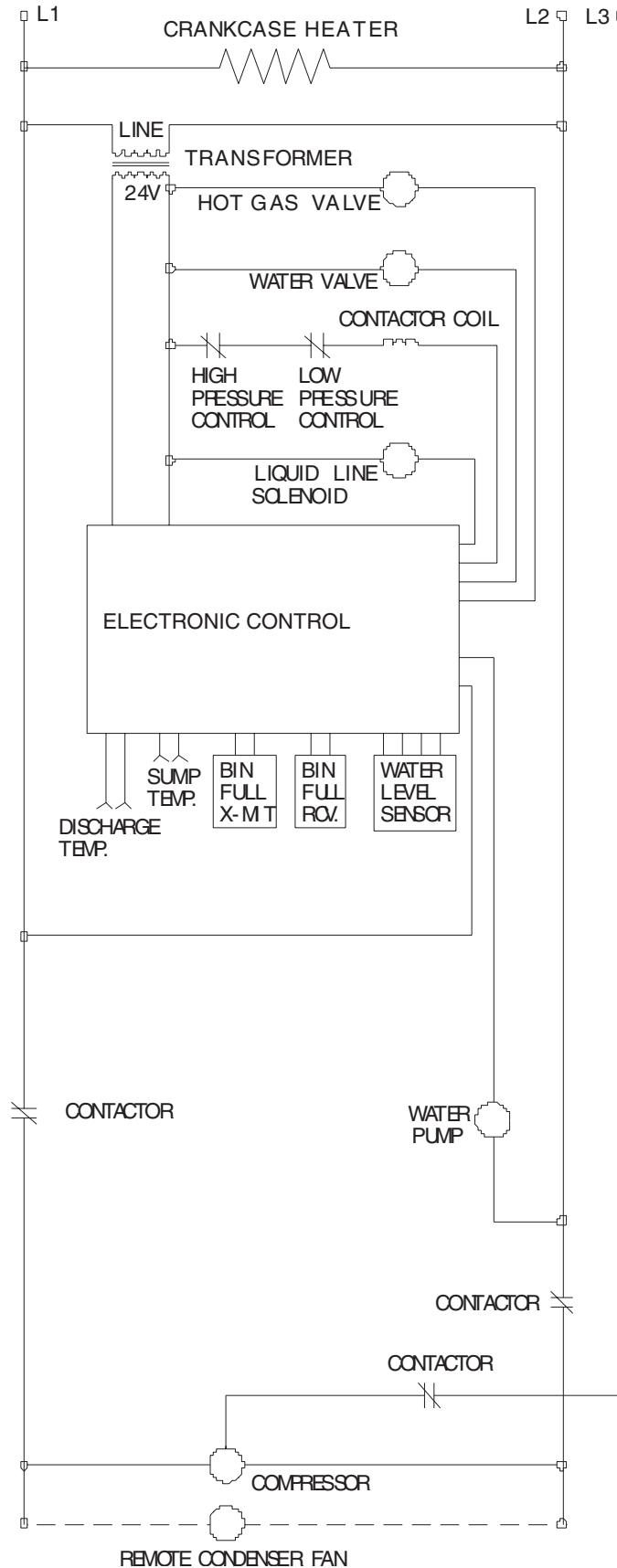

CME506R, CME656R & CME806R Service Parts

D Series, Three Phase Wiring Diagram

17-2758-01

USE COPPER CONDUCTORS ONLY

1 DASHED LINES INDICATE FIELD WIRING WHICH MUST BE INSTALLED IN ACCORDANCE WITH THE NATIONAL ELECTRICAL CODE AND ALL STATE AND LOCAL CODES.

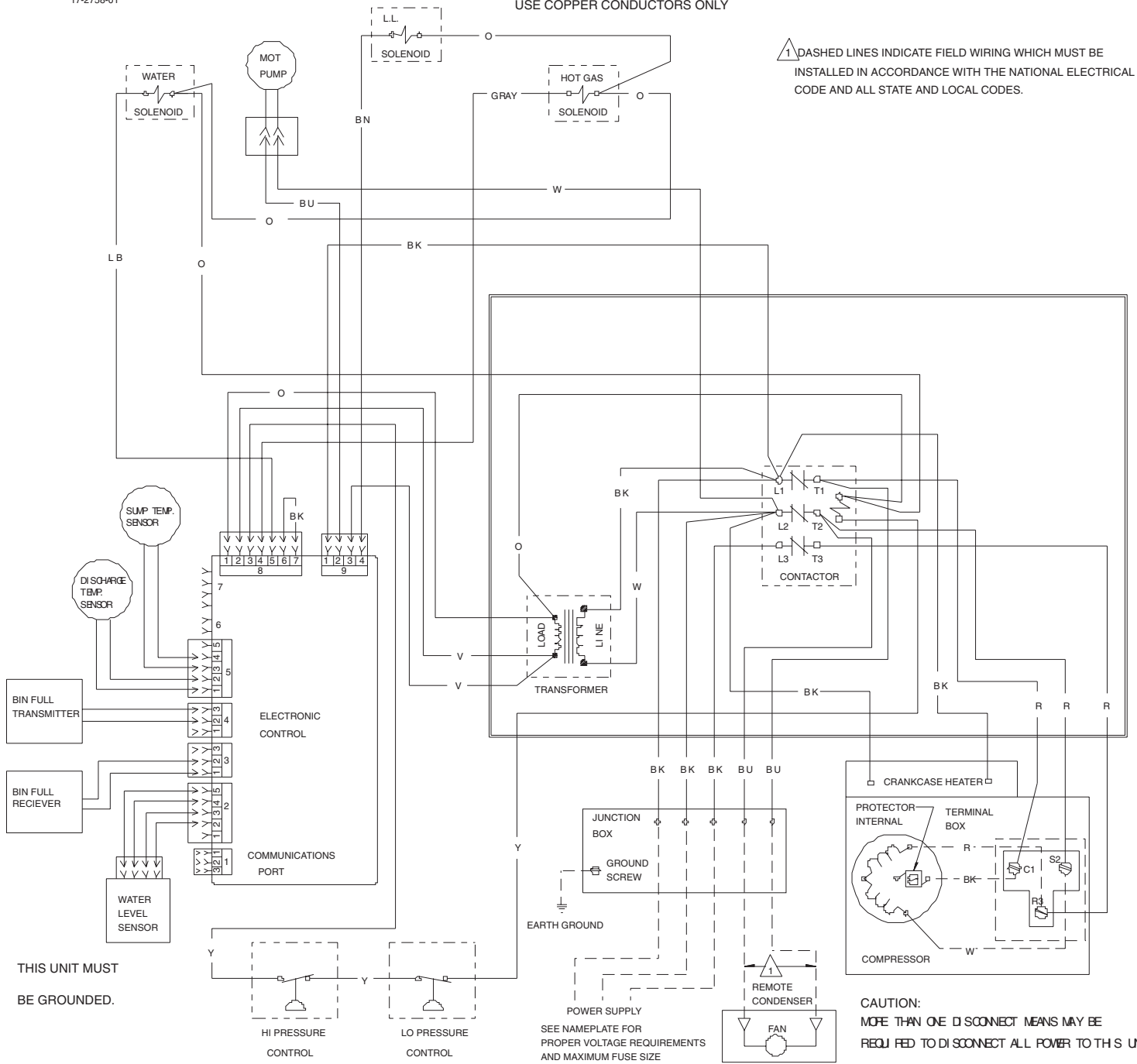

THIS UNIT MUST BE GROUNDED.

CME506R, CME656R & CME806R Service Parts

Single Phase Schematic Diagram, A - C Series

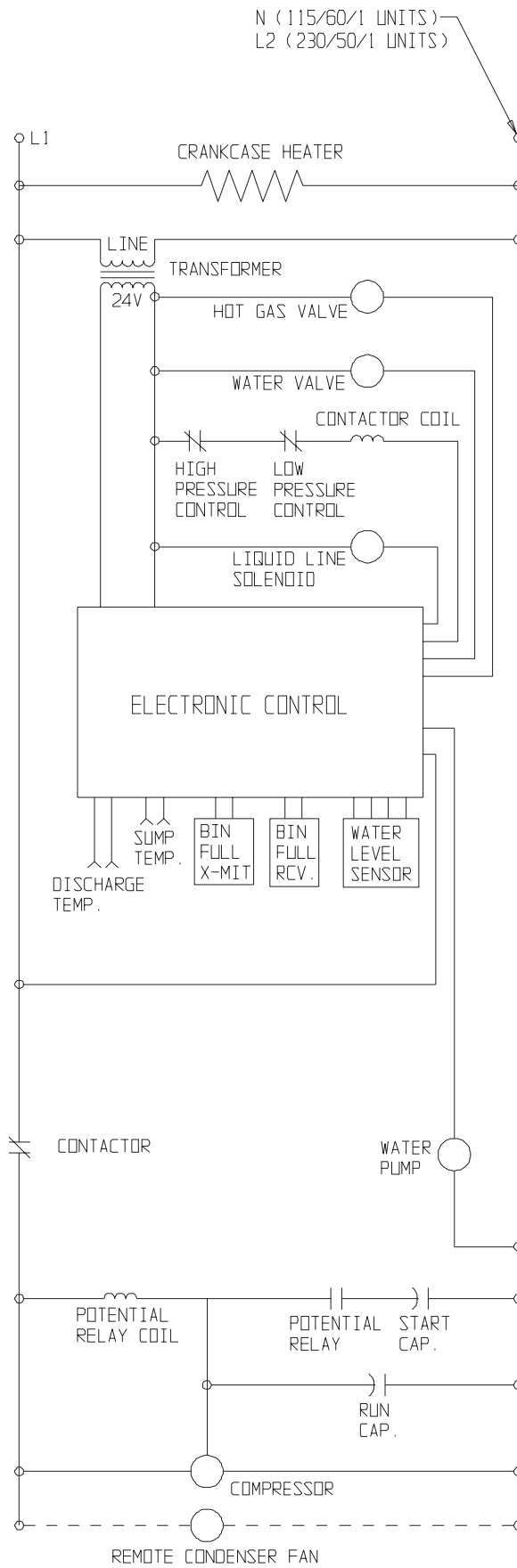

CME506R, CME656R & CME806R Service Parts

A -C Series Single Phase Wiring Diagram

A36671-001

USE COPPER CONDUCTORS ONLY

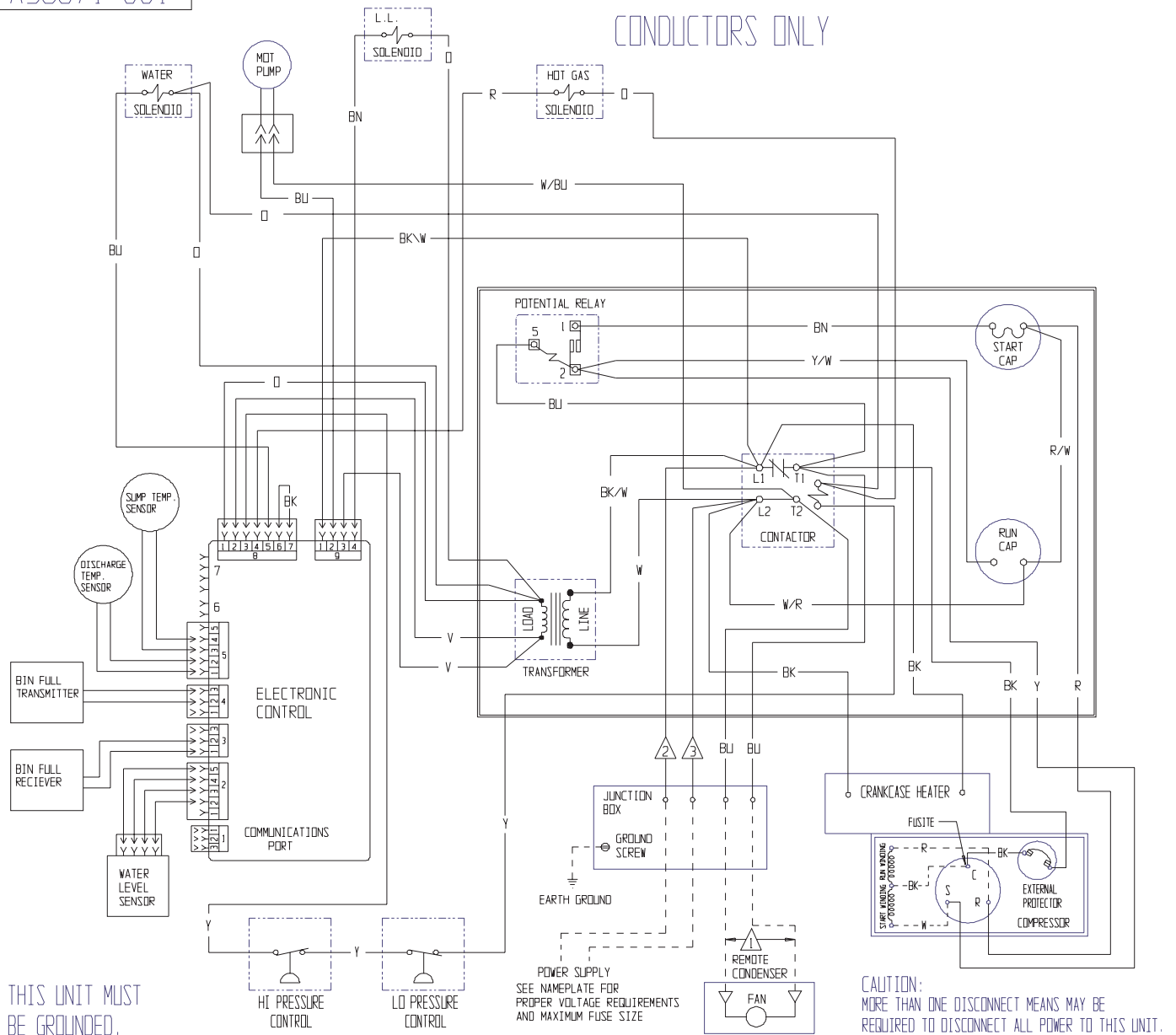

A -C Series Three Phase Schematic Diagram

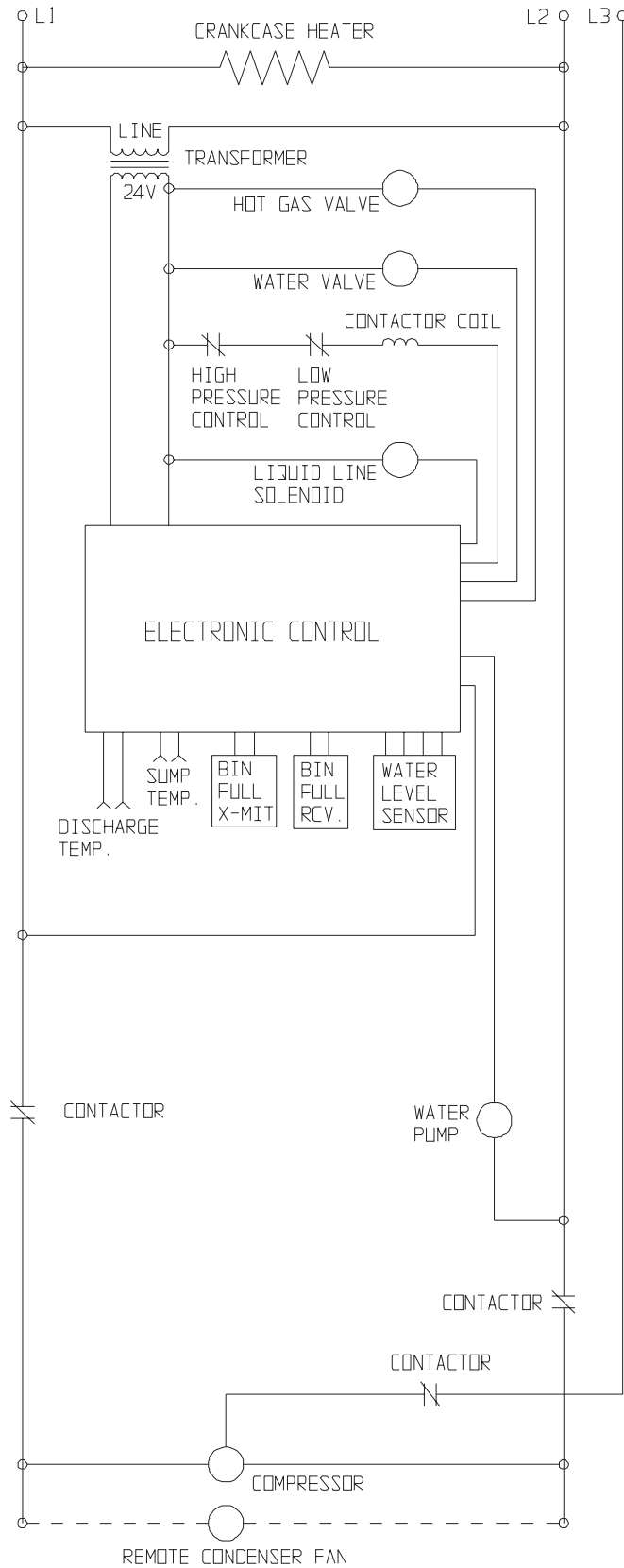

CME506R, CME656R & CME806R Service Parts

A - C Series Three Phase Wiring Diagram

