

## Shell assembly Mod. G250-500 A/W

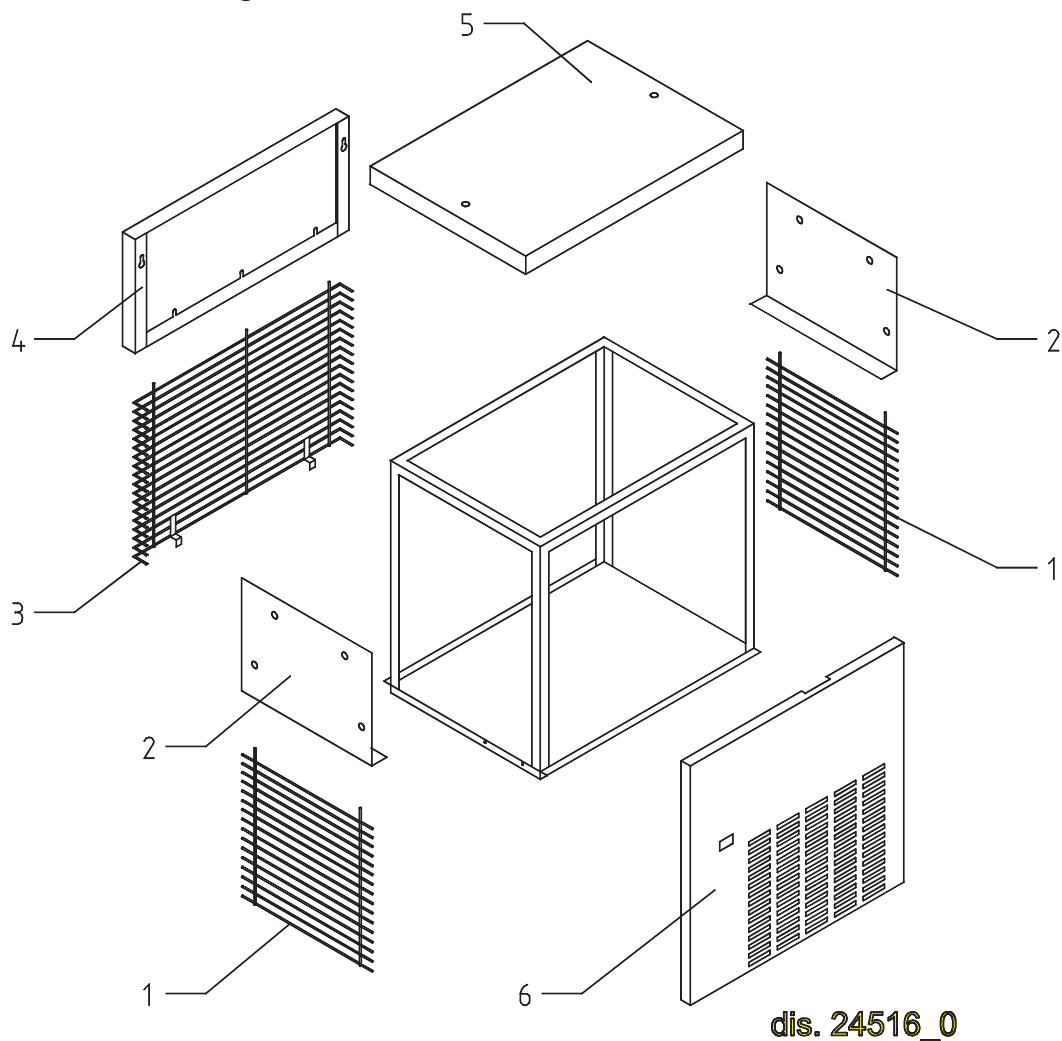

### Shell assembly Mod. G250 A/W (TAB. 68)

Ref.	Description	Refrigerant	A/W	Tension	Code
1	Lateral grid				D12061
2	Right/left panel				22663
3	Back grid				D12060
4	Back panel				22665
5	Top				22667
6	Front panel assembly				C22662B

### Shell assembly Mod. G500 A/W (TAB. 69)

Ref.	Description	Refrigerant	A/W	Tension	Code
1	Lateral grid				D12061
2	Right/left panel				22663
3	Back grid				D12060
4	Back panel				22665
5	Top				22667
6	Front panel assembly				C22662B



**Cooling system assembly Mod. G250 A/W (TAB. 70)**

Ref.	Description	Refrigerant	A/W	Tension	Code
1	Air condenser		A		20426
2	Discharges manifold		A		C10052
2	Discharges manifold		W		C10053
3	Inlet watervlve 1 way				23115
5	Suction fan		A		20407
6	Vacuum-charge valve plug				14006
7	Vacuum-charge valve device				14005
8	Vacuum- charge valve body				14007
9	Compressor			1	23570
9	Compressor			2	23573
10	Bin level control switch				C22099
11	Basin support plate				21133
12	Double switch basin				10145
13	Microswitch				23055
14	Double switch basin assembly				C10201
15	Anti radio interference filter			1	23457
16	Closing disk				22649
17	Seeger				20115
18	Upper inox ballbearing				20112
19	Ice breaker				20484
20	Auger				20515
21	Ceramic seal				20110
22	Foamed evaporator				C11101
24	Ring for ceramic seal				20485
25	S/s thrust (roller) bearing				20111
26	Inox bearing				20113
27	Flange				20482
28	Key				20431
29	Evaporator assy				C11105
30	Half coupling upper				D20517
31	Vibration-damping elastomer				20494
32	Half coupling lower				D20493
33	Fan motor		A		23121
34	Gearmotor				23571
35	Evaporator thermostat				23034
36	Condenser pressure switch		A		23175
37	Anti radio interference filter		A	1	23459
38	Suction impeller		W		10213
39	Fan motor		W		23029
40	Pressure valve		W		20210
41	Solid core drier				14089
42	Safety thermostat		W		C23114
43	Water condenser		W		14034
44	Bin thermostat				23421
45	Contactore				23147
46	Electronic timer				23560
47	Green light switch				23327
49	1 way inlet water nipple		W		10368

**Note:** 4. Code C23192 (W) until number 123470.

20. Code E20481 until number 81177. Code 20515 from number 81178.

29. Code C11102 until number 81177. Code C11105 from number 81178.

30. Code D20493 until number 81177. Code D20517 from number 81178.

20. For machines with previous serial no. of 81178, besides the new auger (Code 20515), ask also for the half coupling upper code D20517. The old auger code E20481 becomes obsolete.

29. For machines with previous serial no. of 81178, besides the new evaporator assy (Code C11105), ask also for the half coupling upper code D20517. The old evaporator assy code C11102 becomes obsolete.

34. Code 23571 except for the following serial number: 77781, 77873, 77874, 77903, 77904, 77919, 77920, 78136, 78137, 78470, 78471, 78548, 78549, 78811, 78812, 78813, 78814, 78960, 79356, 79716 and 79717 which use the code 23532.