

**tav. A**  
**Detail A**  
**Detail A**  
**Détail A**

**tav. B**  
**Detail B**  
**Detail B**  
**Détail B**

**tav. C**  
**Detail C**  
**Detail C**  
**Détail C**

**tav. D**  
**Detail D**  
**Detail D**  
**Détail D**

Serie Serie Série	Modello Modell Modél	Codice Kodex Code	Tav. Detail Détail
<b>SYSTEM 900</b>	<b>ESK/80-E</b>	<b>0107016083</b>	
Primo numero di serie Erste Seriennummer First serial number Première numéro de série	Ultimo numero di serie Letzte Seriennummer Last serial number Dernière numéro de série	Revisione Revision Révision	<b>00</b>
Disegnato Gezeichnet	Approvato Geprüft	File Date	Data Datum
<b>Mantovan L.</b>	<i>Mantovan L.</i>	<b>ESK80E.DWG</b>	<b>14/10/99</b>
<b>ambach</b> GROSSKÜCHENTECHNIK - GRANDI CUCINE			39052 Koltern-Coldaro-ITALY Tel. 0471-662213 Telefax 0471-662065

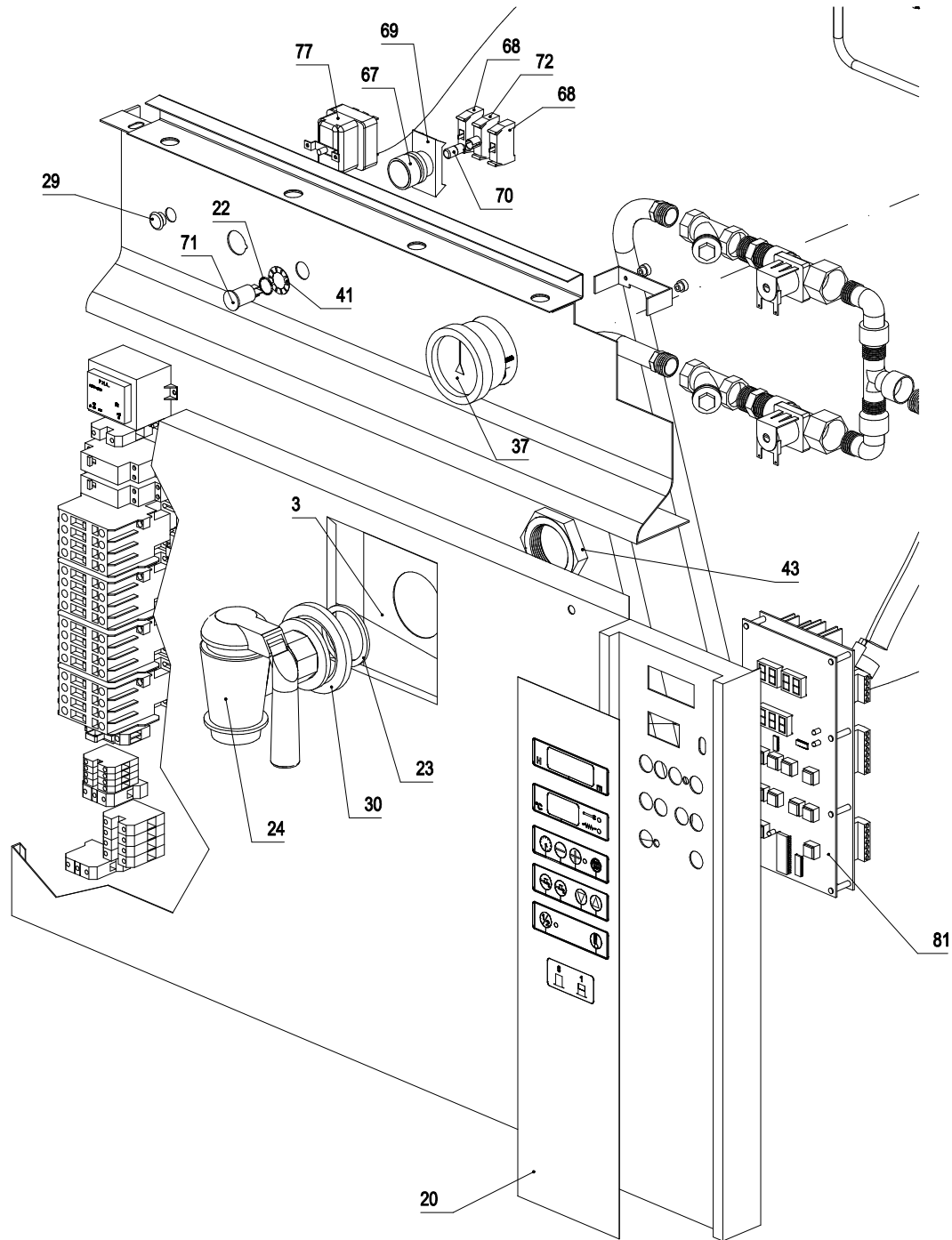

Serie Serie Série	Modello Modell Model	Codice Kodex Code	Tov. Detail Détail
<b>SYSTEM 900</b>	<b>ESK/80-E</b>	<b>0107016083</b>	<b>A</b>
Primo numero di serie Erste Seriennummer First serial number Première numéro de série	Ultimo numero di serie Letzte Seriennummer Last serial number Dernière numéro de série	Revisione Revision Révision	<b>00</b>
Disegnato Gezeichnet	Approvato Geprüft	File Date	Data Datum
<b>Mantovan L.</b>	<i>Mantovan L.</i>	<b>ESK80E.DWG</b>	<b>14/10/99</b>

**ambach**  
GROSSKÜCHENTECHNIK - GRANDI CUCINE

39052 Koltern-Coldaro-ITALY  
Tel. 0471-662213  
Telefax 0471-662065

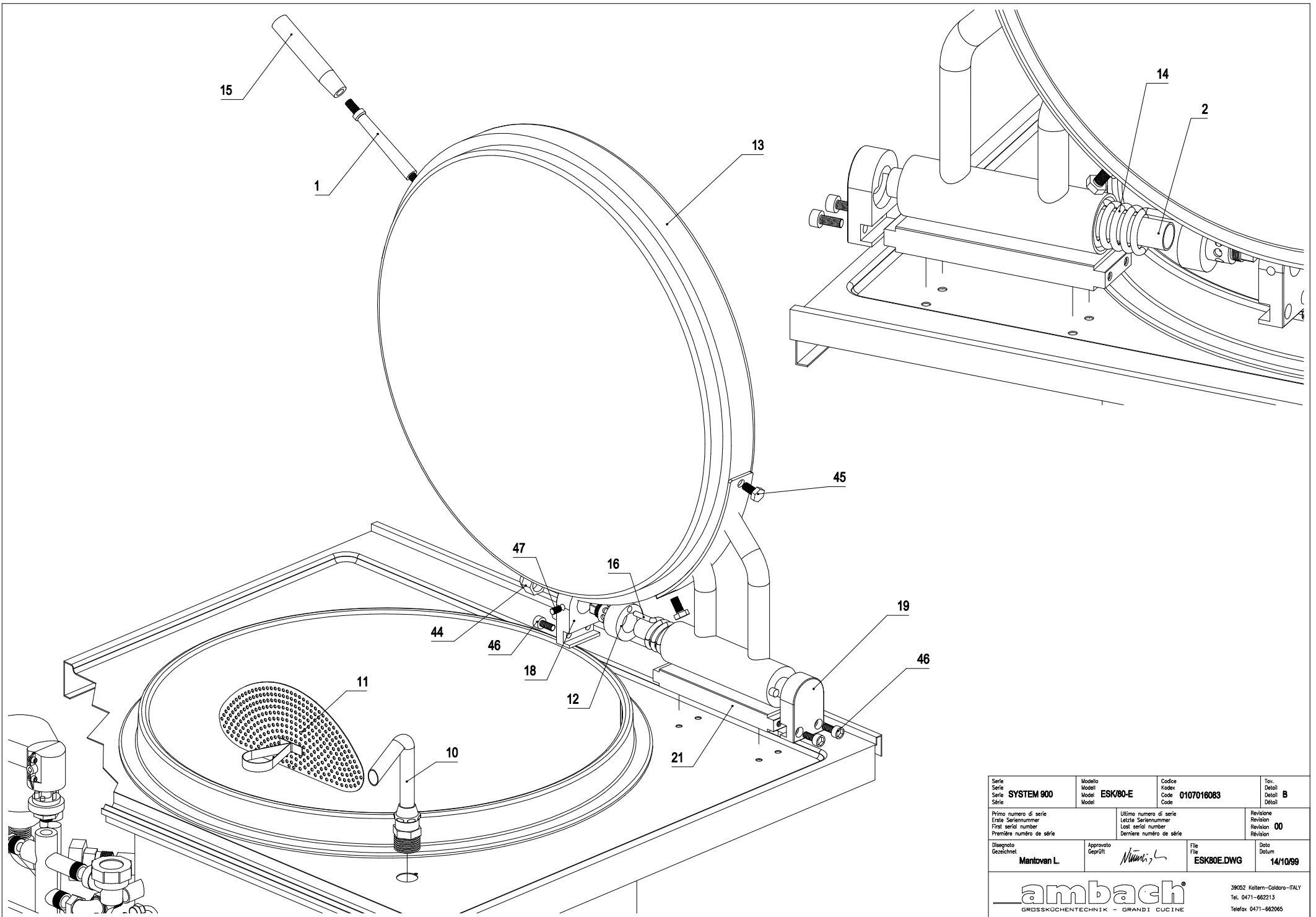

Serie Série Série	Modello Modell Model	Codice Kodex Code	Tov. Detail Détail
<b>SYSTEM 900</b>	<b>ESK/80-E</b>	<b>0107016083</b>	<b>B</b>
Primo numero di serie Erste Seriennummer First serial number Première numéro de série	Ultimo numero di serie Letzte Seriennummer Last serial number Dernière numéro de série	Revisione Revision Révision	<b>00</b>
Disegnato Gezeichnet	Approvato Geprüft	File Date	Data Datum
<b>Mantovan L.</b>	<i>Mantovan L.</i>	<b>ESK80E.DWG</b>	<b>14/10/99</b>
<b>ambach®</b> <small>GROSSKÜCHENTECHNIK - GRANDI CUCINE</small>			<small>39052 Koltern-Caldaro-ITALY          Tel. 0471-662213          Telefax 0471-662065</small>

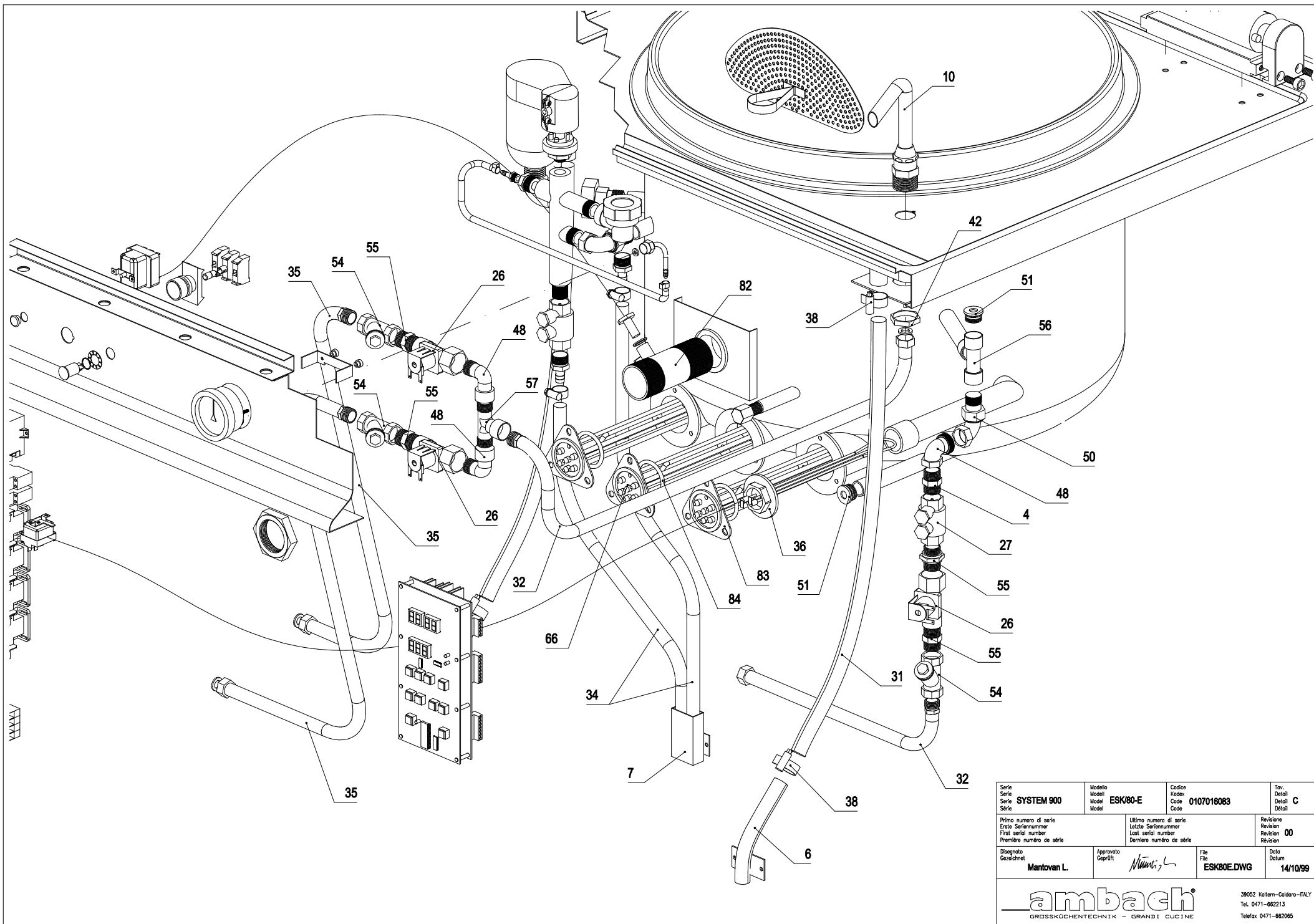

Serie Modelli Model Model	Serie Modelli Model Model	Codice Codice Code Code	Tav. Detail Detail Detail
SYSTEM 900	ESK/80-E	0107016083	C
Primo numero di serie Erste Seriennummer First serial number Première numéro de série	Ultimo numero di serie Letzte Seriennummer Last serial number Dernière numéro de série	Revisione Revision Revision Révision	00
Disegnato Gezeichnet	Approvato Geprüft	File File	Data Datum
Mantovan L.		ESK80E.DWG	14/10/99
			39052 Koltern-Coldaro-ITALY Tel. 0471-662213 Telefax 0471-662065

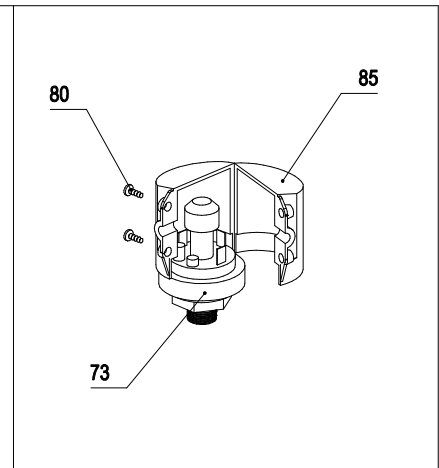
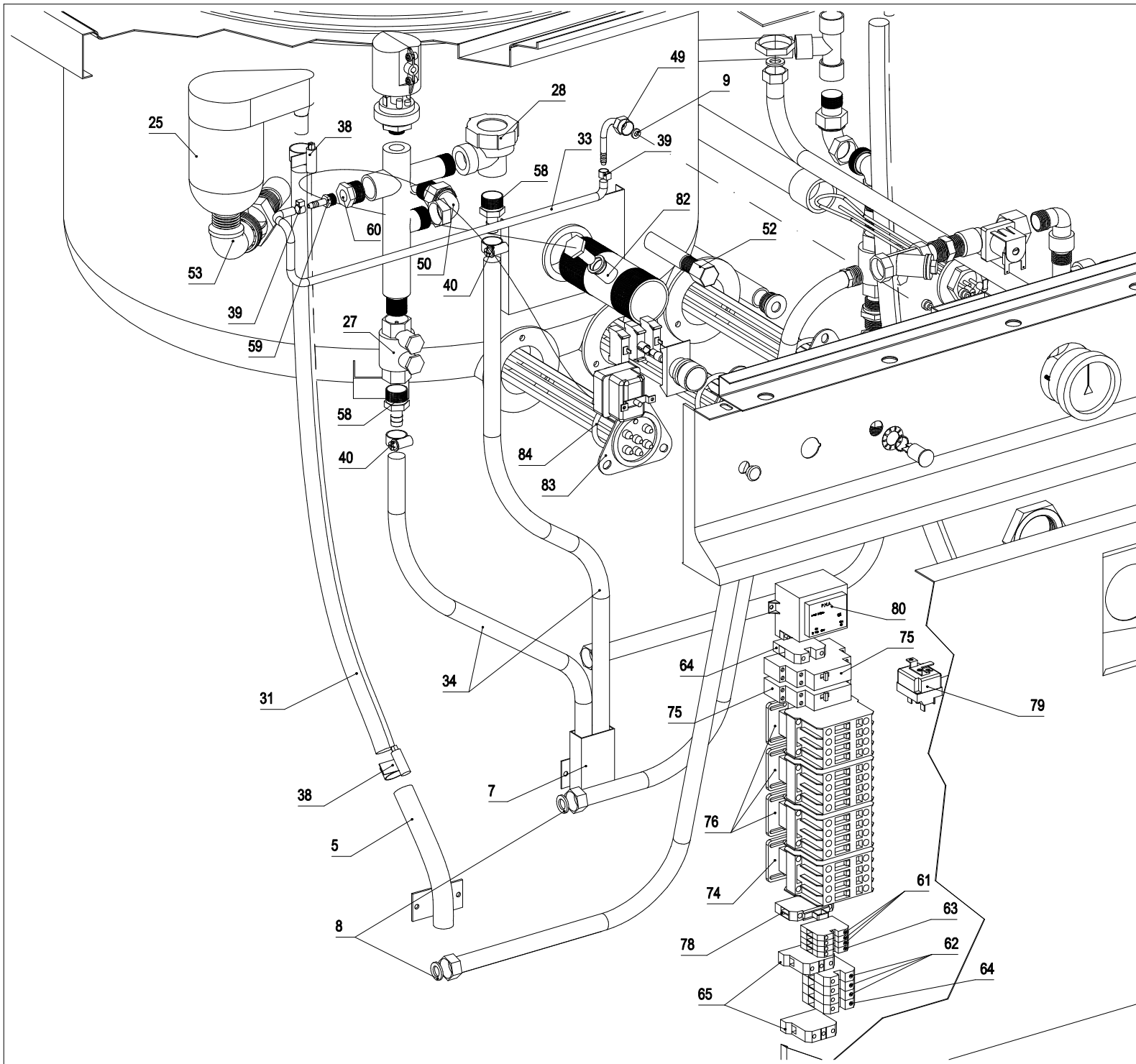

Serie Serie Série	Modello Modell Model	Codice Kodex Code	Tov. Detail Détail
SYSTEM 900	ESK/80-E	0107016083	D
Primo numero di serie Erste Seriennummer First serial number Première numéro de série	Ultimo numero di serie Letzte Seriennummer Last serial number Dernière numéro de série	Revisione Revision Révision	00
Disegnato Gezeichnet	Approvato Geprüft	File Date	Data Datum
Mantovan L.	<i>Mantovan L.</i>	ESK80E.DWG	14/10/99
			39052 Koltern-Coldoro-ITALY Tel. 0471-662213 Telefax 0471-662065

**0107016083 Model: ESK/80E**  
**Elektro Kochkessel 80 Liter**  
**Electric kettle 80 litres**

**Pentola elettrica 80 litri**  
**Marmite électrique 80 litres**

	Code	Beschreibung	Descrizione	Description	Désignation		St/Qty	Start	Finish	SerialNr.
1	3001136215	Welle Griff	Perno maniglia	Switch shaft	Tige de poignée	KK	1			
2	3001114687	Welle Feder Innen	Asse molla interna	Spring shaft inside	Axe de ressort intérieur	ESK/GSK	1			
3	3001814499	Blende Auslauf	Pannello scarico	Drain panel	Panneau de vidange	ESK/GSK/40/80	1			
4	3017215110	Düse Wassereinlauf	Ugello entrata acqua	Water entry jet	Gicleur pour alimentation d'eau	Eco/System	1			
5	3500515444	Rohr Ablauf Links	Tubo scarico sinistro	Left drain tube	Tuyau de vidange gauche	ESK/GSK	1			
6	3500515445	Rohr Ablauf Rechts	Tubo scarico destro	Right drain tube	Tuyau de vidange droite	ESK/GSK	1			
7	3500515570	Rohr Ablauf Mitte	Tubo scarico centrale	Middle drain tube	Tuyau de vidange central	Eco/System	1			
8	5017313786	Dichtung Wasserschlauch	Guarnizione tubo flessibile	Water flexible tube seal	Joint d'étanch. tuyau flexible eau	1/2"	3			
9	5017313787	Dichtung Manometer	Guarnizione manometro	Manometer seal	Joint d'étanchéité manomètre		1			
10	5000508009	Rohr Wassereinlauf	Tubo erogazione acqua	Water supply tube	Tuyau d'alimentation d'eau	1/2" 90°	1			
11	5000804444	Abdeckung Auslauf Kochkessel	Filtro scarico pentola	Boiling pan drain filter	Crépine de marmite	1" 1/2 KK	1			
12	5001109945	Welle Deckelhub Links	Asse alzacoperchio sinistro	Left shaft cover lifting	Axe levage du couvercle gauche	KKK/150-250	1			
13	5003104149	Deckel doppelwandig	Coperchio + controbombato	Double walled cover	Couvercle à double paroi	KK	1			
14	5004714718	Feder Deckelhub	Molla alzacoperchio	Spring cover lifting	Ressort pour levage couvercle	ESK/GSK/40	1			
15	5005607080	Griff Deckel	Maniglia coperchio	Cover handle	Poignée de couvercle	M 10 KSK	1			
16	5006315603	Halter Feder	Supporto molla	Spring holder	Support de ressort	SK/KS/40-60	1			
17	5041703368	Zylinderblechschraube	Vite autofilettante	Cylinder parker screw	Vis à tête cylindrique	3,9x9,5	2			
18	5008914664	Isolierblech außen	Lamiera isolante esterna	External insulation plate	Tôle isolante extérieure	EKB/120	1			
19	5006801972	Isolierung durablanket	Isolazione durablanket	Durablanket insulation	Isolation durablanket	ESK/GSK/100	1			
20	5011810838	Tastaturfolie	Mascherina scheda	Keyboard foil	Membrane protec. de clavier	GNKE/E	1			
21	5012014661	Scharnier Platte	Piastra cerniera	Plate hinge	Charnière de plaque	ESK/GSK/150	1			
22	5017309716	Silikondichtring	Guarnizione anello silicone	Silicon sealing ring	Bague d'étanchéité en silicone	D=18/16x0,5	3			
23	5017323620	Dichtung Sicherheitsentleerha.	Guarnizione rubinetto scarico	Pet safety cock seal	Joint de robinet de vidange	1 1/2"	1			
24	5018013159	Sicherheitsentleerhahn	Rubinetto scarico	Pet safety cock	Robinet de vidange	1 1/2"	1	05/07/00		827051
	5018011342	Sicherheitsentleerhahn	Rubinetto scarico	Pet safety cock	Robinet de vidange	1 1/2"	1		05/07/00	
25	5018015600	Einbau Sicherheitsventil	Valvola di sicurezza interna	Internal safety valve	Soupape de sûreté intérieure	3/4"	1			
26	5018106153	Elektroventil 1/2"	Elettrovalvola 1/2"	Electric valve 1/2"	Electrovanne 1/2"	KMG/KME/50	3			
27	5018114399	Rückschlagventil	Valvola di ritegno	Return valve	Soupape de retenue	Roma 1/2	2			
28	5018117567	Kondensabscheider	Scaricatore di condensa	Condense drainage	Vidange condensât	1/2" BPT13AX-G	1			
29	5019714975	Gummistopfen	Tappo gomma	Rubber plug	Bouchon en caoutchouc		1			
30	5022210634	Rosette	Ghiera	Round plate	Rosace	1.1/2" KK	1			
31	5024608002	Wasserschlauch	Tubo acqua	Water tube	Tuyau d'eau	PE/PK1/40	1,5			
32	5024612524	Flexibler Stahlschlauch	Tubo flessibile	Flexible steel tube	Tuyau flexible en acier	L=500	2			
33	5024610547	Silikonschlauch	Tubo silicone	Silicone tube	Tuyau en silicone	ø5mm>ø8mm	0,6			
34	5024610572	Wasserschlauch	Tubo acqua	Water tube	Tuyau d'eau	ø10mm	1			
35	5024612525	Flexibler Stahlschlauch	Tubo flessibile	Flexible steel tube	Tuyau flexible en acier	L=900	2			
36	5024709751	Pilot Heizkörper	Resistenza controllo acqua	Heating element pilot	Résistance double enveloppe	KSK/150-250	1			
37	5027210517	Manometer	Manometro	Manometer	Manomètre	ESK/GSK	1			
38	5028509493	Rohrschelle	Fascetta per tubo	Pipe clamp	Collier de serrage pour tuyau	D=32-50/13	4			
39	5028510548	Schlauchschele	Fascetta stringitubo	Pipe clamp	Collier de serrage de tuyau	ø7,5>9mm	2			
40	5028510569	Rohrschelle	Fascetta per tubo	Pipe clamp	Collier de serrage pour tuyau	D=20/0 W1	2	25/01/99		702004

41	5040209715	Befestigungsscheibe	Rondella fissaggio	Fastening washer	Rondelle de fixation	D=26 Di=15	2
42	5040320713	Gegenmutter Messing	Controdado ottone	Bass counternut	Contre-écrou laiton	1/2" FIG 310	1
43	5040320714	Gegenmutter Messing	Controdado ottone	Bass counternut	Contre-écrou laiton	1/2" FIG 310	1
44	5040412194	Hutmutter Inox	Dado es. cieco inox	Hexagonal nut inox	Ecrou borgne en inox	KSK/150 M20x1,5	1
45	5041002641	Schraube 6kt	Vite te esagonale	Hexagon screw	Vis hexagonale	10x20 - Inox 18/8	2
46	5041402628	Zylinderschraube in. 6kt	Vite tcei	Hexagon cylinder screw	Vis cylindrique hexagonale	Inox M8x20	4
47	5041810578	Gewindestift innen 6kt	Perno filettato esagonale	Hex-socket set screw	Vis hexagonale sans tête	Inox M8x16	1
48	5050101267	Bogen Messing M+W	Angolo ottone M+F	Elbow brass M+F	Raccord coudé en laiton M+F	1/2" Art. 458	3
49	5051212578	Winkelanschluß	Raccordo a gomito	Angle fitting	Raccord à vis coudé	MS 1/4"	1
50	5050120029	Bogen + Holländer	Gomito ottone	Elbow brass	Raccord coudé	R 19 - 1/2"	2
51	5050201272	Blindstopfen Messing M	Calotta ottone maschio	Capscrew brass male	Tampon borgne mâle laiton	1/2" Art.452	2
52	5050210860	Blindkappe Messing W	Calotta ottone femmina	Capscrew brass female	Calotte femelle laiton	3/8" Art. 453	1
53	5050820701	Holländer MS + Bogen	Bocchettone ottone maschio	Elbow brass male	Raccord coudé en laiton mâle	3/4"	1
54	5050915915	Filter in Messing	Filtro in ottone	Brass filter	Filtre en laiton	1/2"	3
55	5051001287	Doppelnippel Messing	Nipplo doppio ottone	Double nipple brass	Double raccord en laiton	1/2" Art.441	2
56	5051101292	T-Stück Messing	T ottone	T brass	Pièce en T en laiton	1/2" Art.461	2
57	5051101294	T-Stück Messing 1/2" W+M/M	T ottone 1/2" F+M/M	T brass 1/2" F+M/M	Pièce en T en laiton 1/2" F+M/M	Art. 463	1
58	5051210544	Schlauchverschraubung	Portagomma cilindrico	Flexible tube connection	Raccord fileté de flexible	1/2">ø12	2
59	5051210546	Schlauchverschraubung	Portagomma cilindrico	Flexible tube connection	Raccord fileté de flexible	1/4">ø7	1
60	5051310364	Reduzierung Messing	Riduzione ottone	Brass adapter	Douille de réduction en laiton	1/2">1/4" ART.448	1
61	5060513981	Universalklemme grau	Morsetto universale grigio	Grey universal terminal	Borne universelle grise	6QMM	3
62	5060513982	Universalklemme grau	Morsetto universale grigio	Grey universal terminal	Borne universelle grise	16QMM	3
63	5060513984	Null-Leiterklemme blau	Morsetto neutro blu	Blue neutral terminal	Borne neutre bleue	6QMM	1
64	5060513985	Null-Leiterklemme blau	Morsetto neutro blu	Blue neutral terminal	Borne neutre bleue	16QMM	2
65	5060513988	Erdungsklemme gelb/grün	Morsetto terra giallo/verde	Yellow/green ground terminal	Borne de terre jaune/verte	16QMM	2
66	5060810064	Heizkörper 6000W	Resistenza 6000W	Heating element 6000W	Résistance 6000W	KKE (IRCA)	1
67	5060919757	Druckschalter beleuchtet	Pulsante passo passo	Pressing switch lighting	Bouton poussoir lumineux	TP/KSK	1 03/05/99
68	5060919758	Kontaktelement	Contatti	Contact element	Élément de contact	N.A. TP/KSK	2 03/05/99
69	5060919759	Halter Kontaktelement	Basetta portacontatti	Contact element holder	Support d'élément de contact	TP/KSK	1
70	5061103274	Glimmlampe Neon	Lampada spia neon	Neon control lamp	Lampe de contrôle au néon	BA 9S 220V	2
71	506110293	Signalleuchte rot	Lampada spia rossa	Red control lamp	Voyant lumineux rouge	230V T150° C	1
72	5061119760	Lampenelement	Elemento lampada	Lamp element	Élément de lampe	TP/KSK	1
73	5061315480	Druckwächter Dampfüberwach.	Pressostato controllo vapore	Pressure switch steam control	Pressostat - contrôle de vapeur		1
74	5061407226	Schütz CGE CL25	Contattore CGE CL25	Contacto CGE CL25	Contacteur-disjonc. CGE CL25	A300T6 230V	1
75	5061410308	Kontakt-Relais	Relé impulso	Contact relay	Relais contact	TL 1P 16A 220V	2
76	5061411123	Schütz CGE CL02	Contattore CGE CL02	Contacto CGE CL02	Contacteur-disjonc. CGE CL02	A400T6	3 16/02/00
77	5061603828	Sicherheitsthermostat	Termostato limitatore	Safety thermostat	Thermostat de sécurité	KKE/PE	1
78	5061807908	Sicherungshalter	Porta fusibile	Fuse holder	Porte-fusible	Siemens	1
79	5061609772	Thermostat Wasserfüllung	Termostato controllo livello	Thermostat water control	Thermostat contrôle niveau eau	KSK	1
80	5062808246	Transformator	Trasformatore	Transformer	Transformateur	KSKE/TPE/16	1
81	5062909870	Platine	Scheda comando	Electronic plate	Platine électronique	TPE/190	1
82	5051013254	Nippel Auslauf	Nipplo scarico	Drain nipple	Raccord fileté de vidange	ESK/80-150E	1
83	5060810064	Heizkörper 4500W	Resistenza 4500W	Heating element 4500W	Résistance 4500W	KKE (IRCA)	2
84	5017313781	Gummidichtung O-Ring	Guarnizione o-ring	Rubber gasket o-ring	Joint torique en caoutchouc	EUK/45	2
85	5003116222	Deckel Druckwächter	Coperchio pressostato	Cover pressure control device	Couvercle pressostat		1
86	5061809773	Sicherung	Fusibile	Fuse	Fusible	8A TPME/KKME	2
87	5061807231	Sicherung	Fusibile	Fuse	Fusible	6,3 A	1

5050909752	Schützentstörfilter	Filtro antidisturbo	Radioshielding filter	Filtre antiparasites	400 V	5	16/02/00	807011
5050912346	Schützentstörfilter	Filtro antidisturbo	Radioshielding filter	Filtre antiparasites	130/240 V	2	12/04/00	815097
5003012322	Distanzstück Nippel Auslauf	Distanziale nipplo scarico	Spacer block drain nipple	Pièce interc. raccord fil. vidange	1 1/2"	1	20/03/01	799564