



Applus®
LGAI
Organismo
Notificado
0370

AENOR
Organismo
Notificado
0099



TOLERANCIAS GENERALES: ±0.5 mm

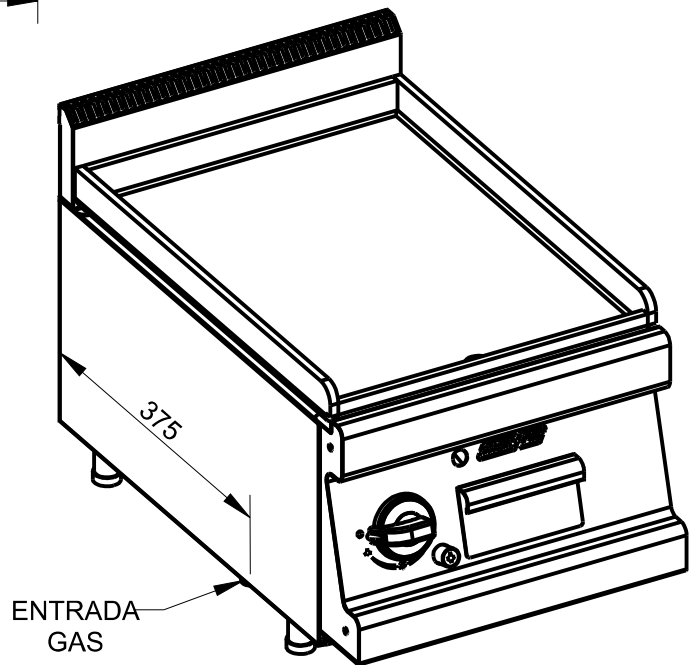
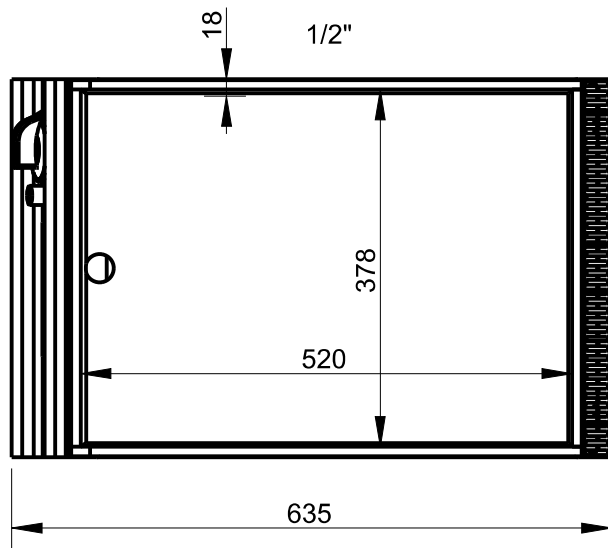
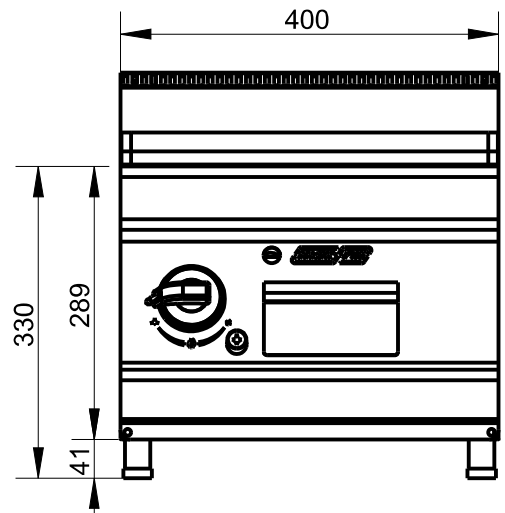
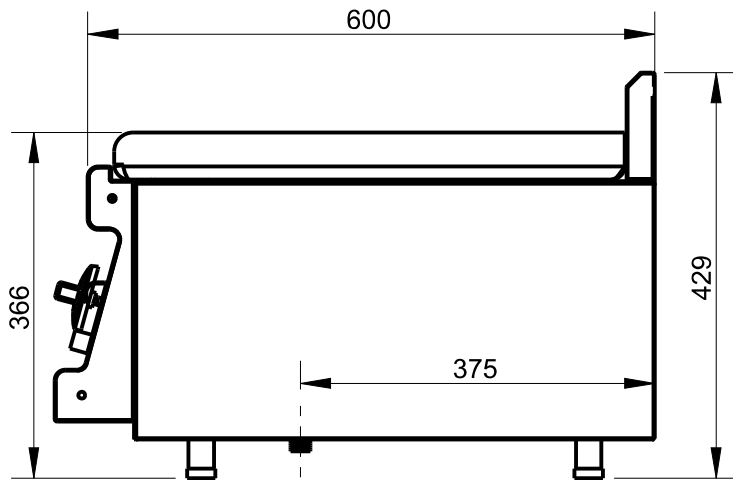

POTENCIA TOTAL: 4,8 KW



FAMILIA: COCINAS 2008

FECHA: 24/05/11

MODELO: 3001/2

PESO(Kg): 35.093

DENOMINACION:
PLANCHA SNACK LC 400

ESCALA:
1/8

MATERIAL:
INOX

CODIGO:
3001/2



Applus®
LGA1
Organismo
Notificado
0370

AENOR
Organismo
Notificado
0099



TOLERANCIAS GENERALES: ±0.5 mm

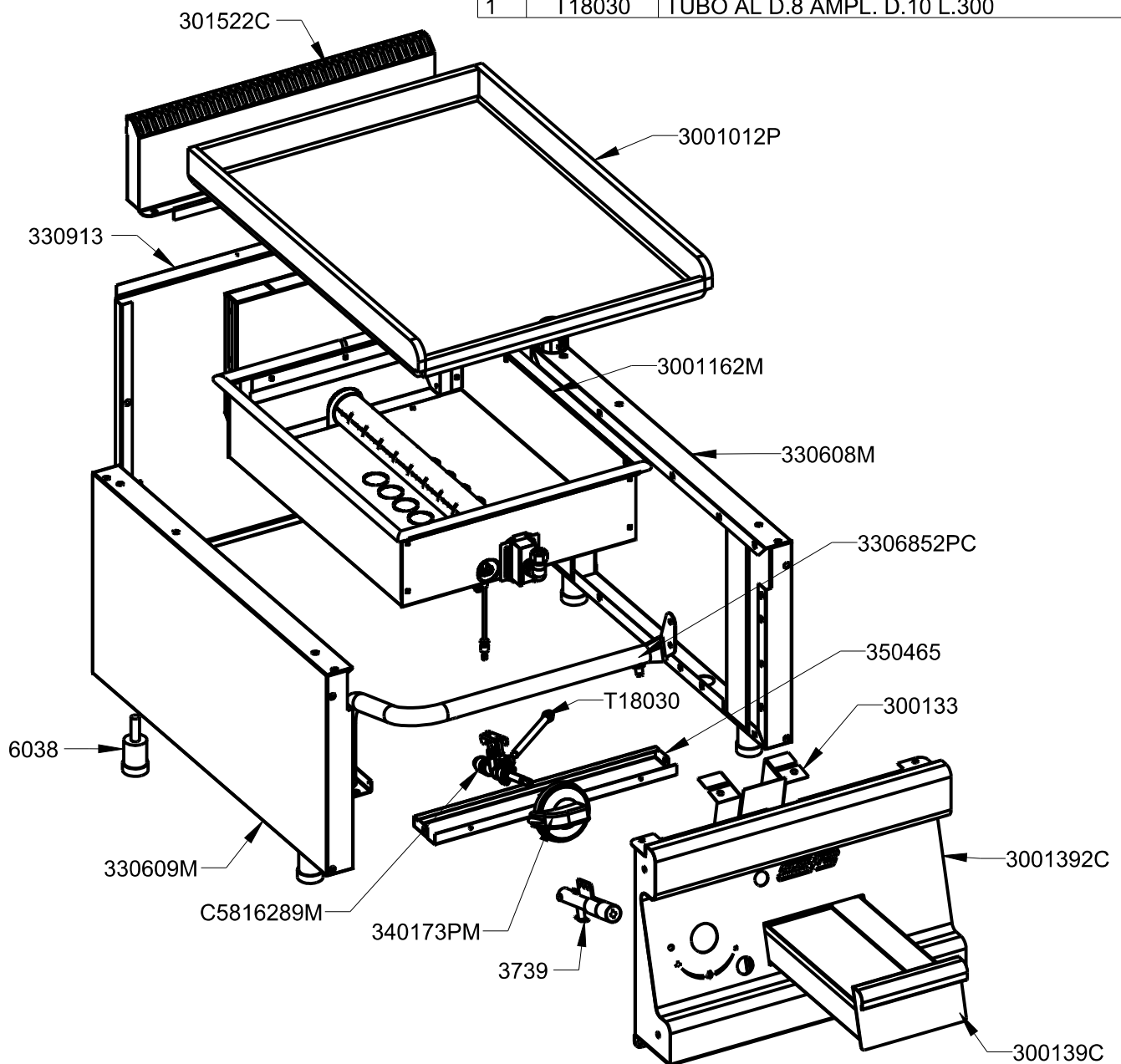
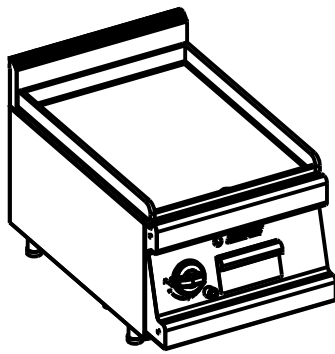

QT	COD	DESCRIPCION
1	3739	ENCENDIDO PIEZOELECTRICO
4	6038	PATA REGULABLE AP.SNACK
1	300133	RAMPA CAÍDA ACEITE
1	330913	TRASERO HORNILLO 400
1	350465	FRONTAL INFERIOR 400
1	3001012P	PLANCHA PAVONADA 10mm 400X590
1	3001162M	DEFLECTOR MONTADO/2 400X600
1	3001392C	CONJ. FR.PLANCHA SNACK/2 400
1	301522C	CONJ. PETO SNK CORTO 400
1	330608M	CONJ. LATERAL SUPERIOR 600 DCH
1	330609M	CONJ. LATERAL SUPERIOR 600 IZQ
1	3309852PC	BATERIA COMPLETA FT/2 400
1	340173PM	CONJUNTO MANDO A GAS
1	3621492C	CONJUNTO CAJON FT/2
1	C5816289M	CONJUNTO GRIFO EJE LARGO
1	T18030	TUBO AL D.8 AMPL. D.10 L.300



FAMILIA: COCINAS 2008

FECHA: 24/05/11

MODELO: 3001/2

PESO(Kg): 35.093

DENOMINACION:
PLANCHA SNACK LC 400

ESCALA:
1/8

MATERIAL:
INOX

CODIGO:
3001/2



Applus®
LGA1
Organismo Notificado
0370

AENOR
Organismo Notificado
0099



TOLERANCIAS GENERALES: ±0.5 mm

QT	COD	DESCRIPCION	FAB.	MATERIAL	DATA	PESO
1	3739	ENCENDIDO PIEZOELECTRICO	SÍ	INOX	29/04/11	0.098
1	300133	RAMPA CAÍDA ACEITE	SÍ	INOFER 0.8	18/07/08	0.118
1	300152	SALIDA VAHOS PL400	SÍ	GALVA 0.8	11/05/09	0.715
1	300178	TAPETA LATERAL DCHA.FR.CORTO 600	SÍ	INOFER 1.2	09/10/07	0.154
1	300179	TAPETA LATERAL IZQ.FR.CORTO 600	SÍ	INOX 1.2	26/06/07	0.154
1	300184	AIREADOR QUEMADOR	SÍ	INOFER 0.8	09/06/09	0.023
2	300378	TAPETA LATERAL DEFLECTOR	SÍ	GALVA 0.8	06/05/09	0.027
1	301522	PETO SOBRE SNACK 400 CORTO	SÍ	INOX 1.2	10/12/08	0.598
1	301578	TAPETA DERECHA PETO CORTO SNK	SÍ	INOFER 1.2	09/10/07	0.072
1	301579	TAPETA IZQ. PETO CORTO SNK	SÍ	INOFER 1.2	09/10/07	0.072
1	330194	PLETINA LATERAL BATERÍA	SÍ	FE 1.5	03/11/08	0.012
1	330294	PLETINA BASE BATERÍA	SÍ	FE 1.5	03/11/08	0.021
1	330608	LATERAL SUPERIOR 600 DCHO	SÍ	INOFER 0.8	29/10/08	1.456
1	330609	LATERAL SUPERIOR 600 IZQ	SÍ	INOFER 0.8	29/10/08	1.456
3	330675	REFUERZO PATA	SÍ	GALVA 1.5	11/12/08	0.429
1	330913	TRASERO HORNILLO 400	SÍ	INOFER 0.8	11/12/08	0.931
1	350465	FRONTAL INFERIOR 400	SÍ	INOFER 0.8	15/06/10	0.180
1	362126	BURL.CERAM.400x600/750-C6580179	SÍ	FIBRA	20/01/09	0.170
1	362149	TIRADOR CAJON FT (GN2/8-65)	SÍ	INOX 1.2	19/11/07	0.162
1	362176	SOPORTE-ADAPT.PIEZO SIT-JUNK	SÍ	INOFER 0.8	18/05/11	0.035
1	3001392	FRONTAL MANDOS PL.SNACK/2 400	SÍ	INOX 1.2	24/05/11	1.744
1	3001492	CAJON FRYTOP/2	SÍ	INOFER 0.8	24/05/11	0.527
1	3306751	REFUERZO PATA C/ENCAJE BATERIA	SÍ	GALVA 1.5	09/01/09	0.361
1	3621162	DEFLECTOR FT/2 400X750/600	SÍ	INOFER 0.8	24/05/11	1.586
1	3621482	GUIA CAJON FT/2	SÍ	INOFER 0.8	24/05/11	0.246
1	3001162M	DEFLECTOR MONTADO/2 400X600	SÍ	INOX	24/05/11	3.115
1	3001392C	CONJ. FR.PLANCHA SNACK/2 400	SÍ	INOX	24/05/11	2.389
1	301522C	CONJ. PETO SNK CORTO 400	SÍ	INOX	10/12/08	0.758
1	330608M	CONJ. LATERAL SUPERIOR 600 DCH	SÍ	INOX	17/01/11	2.330
1	330609M	CONJ. LATERAL SUPERIOR 600 IZQ	SÍ	INOX	17/01/11	2.261
1	3621492C	CONJUNTO CAJON FT/2	SÍ	INOX	24/05/11	0.689
2	TESTA140	ANGULO TESTATINA 140	SÍ	INOX 0.6	29/08/07	0.016
6	TESTA35	ANGULO TESTATINA 35	SÍ	INOX 0.6	29/08/07	0.004
2	TESTA70	ANGULO TESTATINA 70	SÍ	INOX 0.6	29/08/07	0.008
4	1014	REMACHE ROSCADO M-10	NO	ZN	17/12/09	0.008
1	2175	CABLE PIEZO L=760	NO	FIBRA/CU	01/01/09	0.013
1	3705	SOPORTE SUPERIOR	NO	FE	03/02/09	0.005
1	3786	SOPORTE INFERIOR	NO	FE	03/02/09	0.009
4	6038	PATA REGULABLE AP.SNACK	NO	BAQUELITA	01/12/93	0.068
1	31691	BRIDA 1/2" SABAF	NO	FE ZN	13/02/09	0.011
1	3001012P	PLANCHA PAVONADA 10mm 400X590	NO	FE DEC.10mm	24/05/11	21.219
1	300187P	QUEMADOR TUBULAR D.40 L.400	NO	INOX	05/08/09	0.424
1	3309852P	BATERÍA FT/2 400	NO	FE 1/2"	24/05/11	0.453
1	3309852PC	BATERIA COMPLETA FT/2 400	NO	FE ZN	24/05/11	0.499
1	340172P	EMBELLECEDOR MANDO GAS/ELECT.	NO	ABS	10/12/07	0.018
1	340173P	MANDO COCINA GAS 2008	NO	BAQUELITA	10/12/07	0.064
1	340173PM	CONJUNTO MANDO A GAS	NO	BAQUELITA	10/12/07	0.082
1	3786M	CONJUNTO TERMOPAR-BUJIA	NO	VARIOS	03/02/09	0.059



FAMILIA: COCINAS 2008

FECHA: 24/05/11

MODELO: 3001/2

PESO(Kg): 35.093

DENOMINACION:
PLANCHA SNACK LC 400

ESCALA:
1/10

MATERIAL:
INOX

CODIGO:
3001/2



Applus®
LGA1
Organismo
Notificado
0370

AENOR
Organismo
Notificado
0099



TOLERANCIAS GENERALES: ±0.5 mm

2	C1061243	TORNILLO M-4X25 DIN933 ZN	NO	FE ZN	12/02/09	0.003
1	C3704	TORNILLO ZN SIT	NO	FE ZN	03/02/09	0.004
1	C5811809	TERMOPAR M8 C/LISA L.850	NO	CU	03/02/09	0.022
1	C5812649	INY. D.110 GLP QUEM. L.400	NO	LATON	01/01/09	0.012
1	C5812669	INY. D.160 GN QUEM.L.400	NO	LATON	01/01/09	0.012
1	C5815159	PORTAINYECTOR COMPLETO	NO	LATON	01/01/09	0.058
1	C5815559	BICONO D.8 SABAF	NO	LATON	13/02/09	0.001
1	C5815569	TUERCA 1/4" D.8 SABAF	NO	FE ZN	13/02/09	0.003
1	C5816289	GRIFO COCINA ECO +15MM	NO	LATON	11/02/09	0.102
1	C5816289M	CONJUNTO GRIFO EJE LARGO	NO	LATON	11/02/09	0.124
1	C5816309	TOMA DE PRESIÓN PARA BATERIA	NO	LATON	31/03/11	0.013
1	C5820109	BUJIA	NO	CER	22/10/02	0.007
1	T18030	TUBO AL D.8 AMPL. D.10 L.300	NO	AL 99.7%	15/04/10	0.027



FAMILIA: COCINAS 2008

FECHA: 24/05/11

MODELO: 3001/2

PESO(Kg): 35.093

DENOMINACION:
PLANCHA SNACK LC 400

ESCALA:
1/10

MATERIAL:
INOX

CODIGO:
3001/2



Applus®
LGA1
Organismo
Notificado
0370

AENOR
Organismo
Notificado
0099



TOLERANCIAS GENERALES: ±0.5 mm

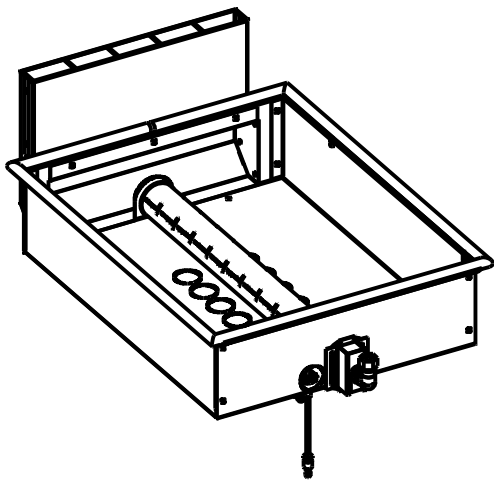

QT	COD	DESCRIPCION
1	300152	SALIDA VAHOS PL400
1	300184	AIREADOR QUEMADOR
2	300378	TAPETA LATERAL DEFLECTOR
1	362126	BURL.CERAM.400x600/750-C6580179
1	3621162	DEFLECTOR FT/2 400X750/600
1	300187P	QUEMADOR TUBULAR D.40 L.400
1	3786M	CONJUNTO TERMOPAR-BUJIA
1	C5812649	INY. D.110 GLP QUEM. L.400
1	C5812669	INY. D.160 GN QUEM.L.400
1	C5815159	PORTAINYECTOR COMPLETO

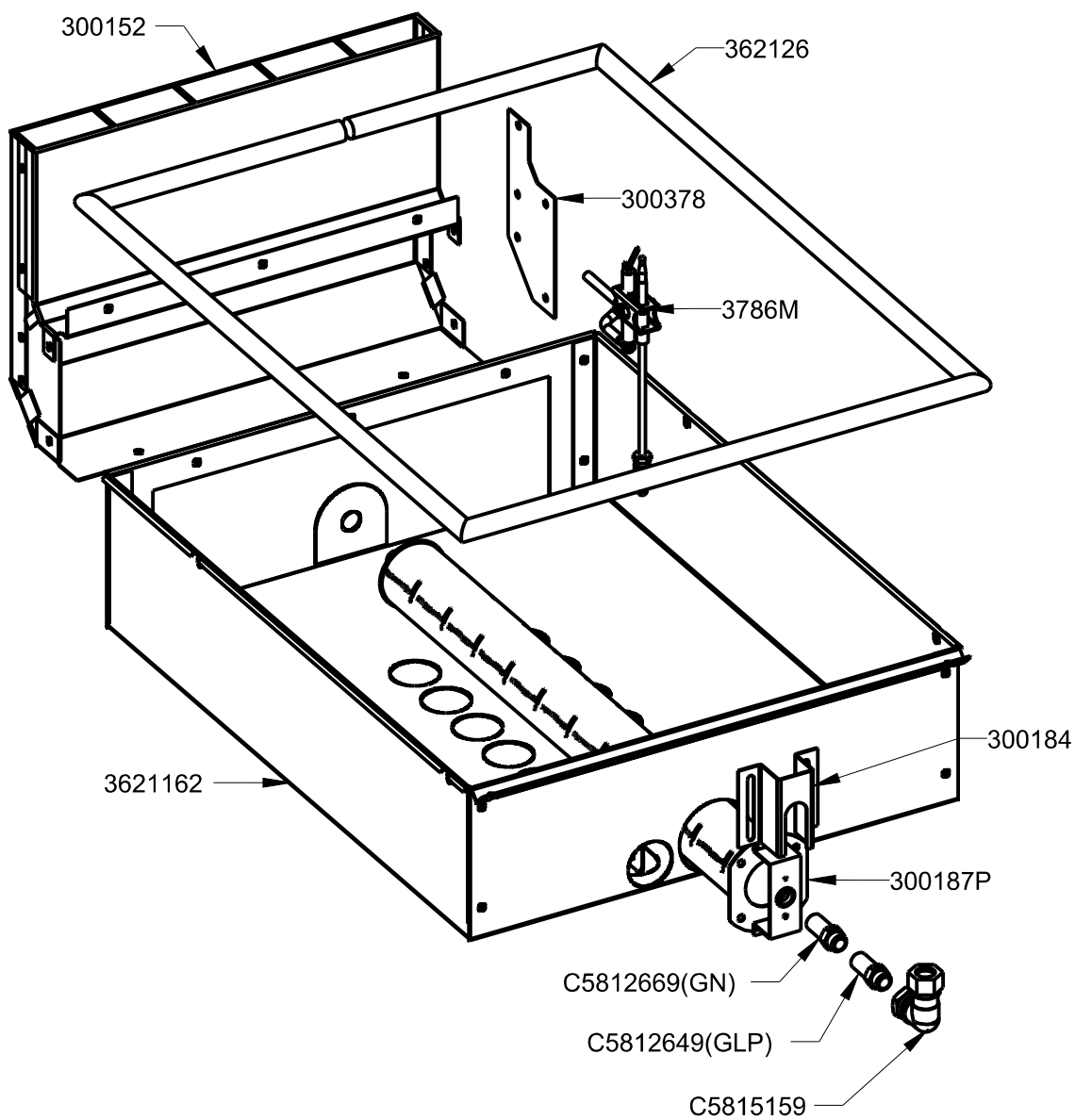

FAMILIA: COCINAS 2008

FECHA: 24/05/11

MODELO: 3001/2

PESO(Kg): 3.115

DENOMINACION:
DEFLECTOR MONTADO/2 400X600

ESCALA:
1/4

MATERIAL:
INOX

CODIGO:
3001162M



Applus®
LGA1
Organismo
Notificado
0370

AENOR
Organismo
Notificado
0099



TOLERANCIAS GENERALES: ±0.5 mm

QT	COD	DESCRIPCION
1	2175	CABLE PIEZO L=760
1	3705	SOPORTE SUPERIOR
1	3786	SOPORTE INFERIOR
1	C3704	TORNILLO ZN SIT
1	C5811809	TERMOPAR M8 C/LISA L.850
1	C5820109	BUJIA

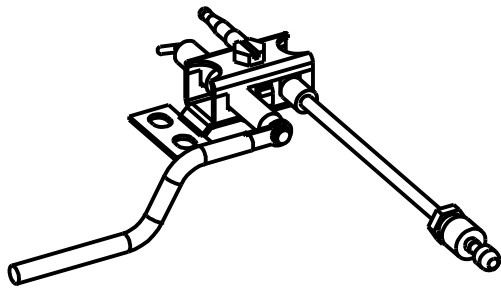

3704

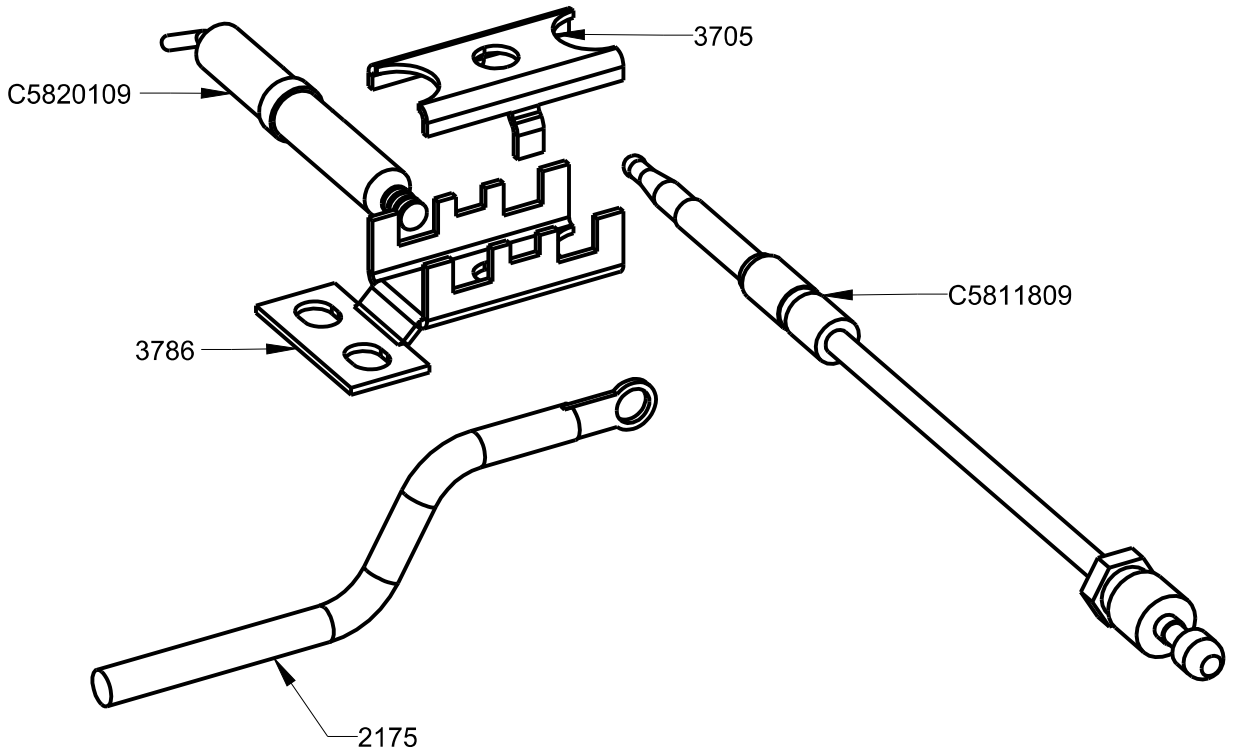

FAMILIA: COCINAS 2008

FECHA: 03/02/09

MODELO: 4901

PESO(Kg): 0.059

DENOMINACION:
CONJUNTO TERMOPAR-BUJIA

ESCALA:
1/1

MATERIAL:
VARIOS

CODIGO:
3786M



Applus®
LGAI
Organismo
Notificado
0370

AENOR
Organismo
Notificado
0099



TOLERANCIAS GENERALES: ±0.5 mm

QT	COD	DESCRIPCION
1	31691	BRIDA 1/2" SABAF
2	C1061243	TORNILLO M-4X25 DIN933 ZN
1	C5815559	BICONO D.8 SABAF
1	C5815569	TUERCA 1/4" D.8 SABAF
1	C5816289	GRIFO COCINA ECO +15MM

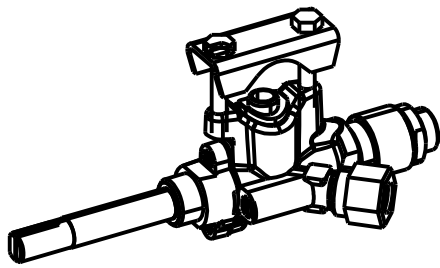

ESCALA 1/2

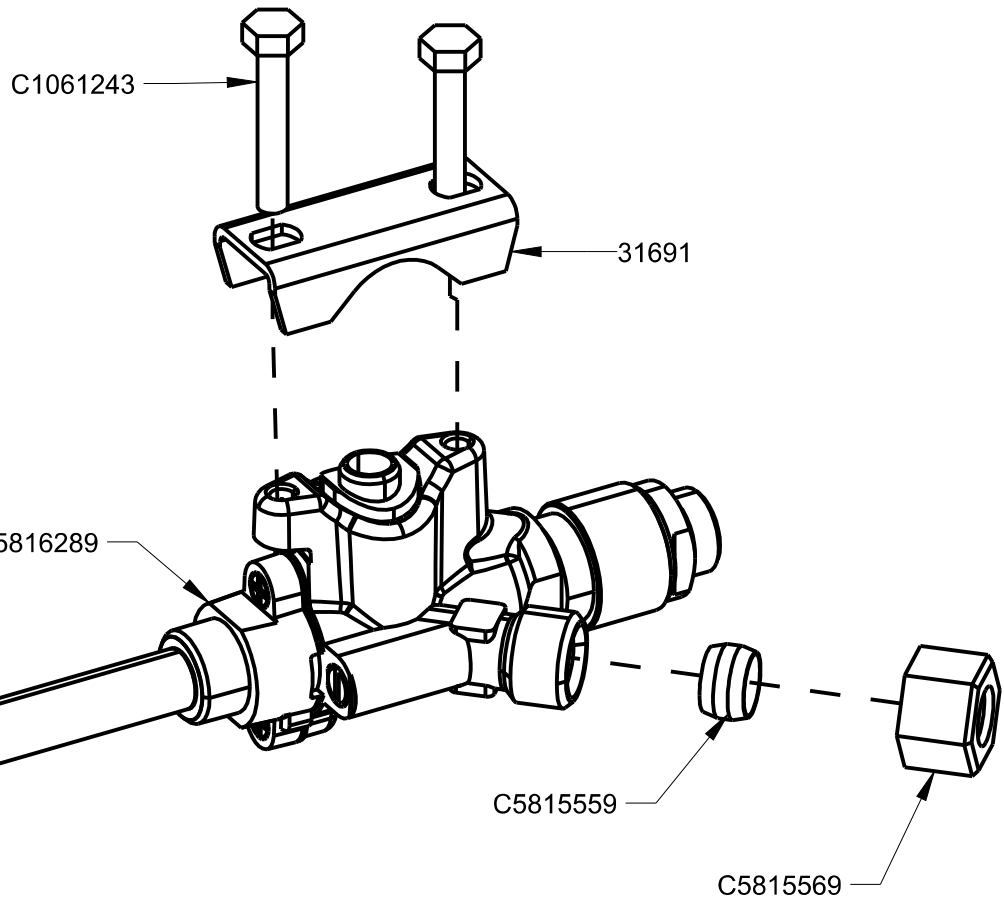
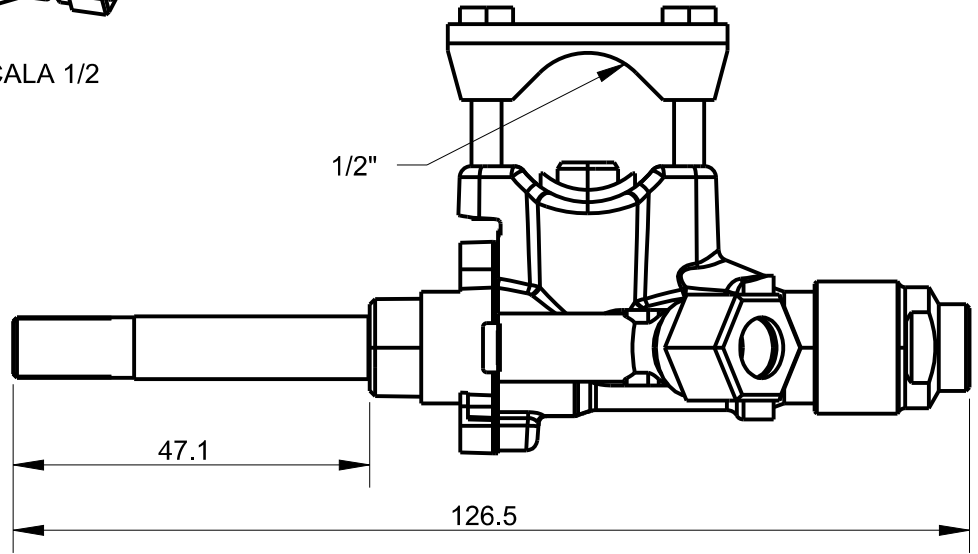

FAMILIA: COCINAS 2008

FECHA: 11/02/09

MODELO: 3300

PESO(Kg): 0.124

DENOMINACION:
CONJUNTO GRIFO EJE LARGO

ESCALA:
1/1

MATERIAL:
LATON

CODIGO:
C5816289M