

Shell assembly + Hydraulic circuit Mod. CB246-249-316-416-425-640-840-955-1265-1565 A/W

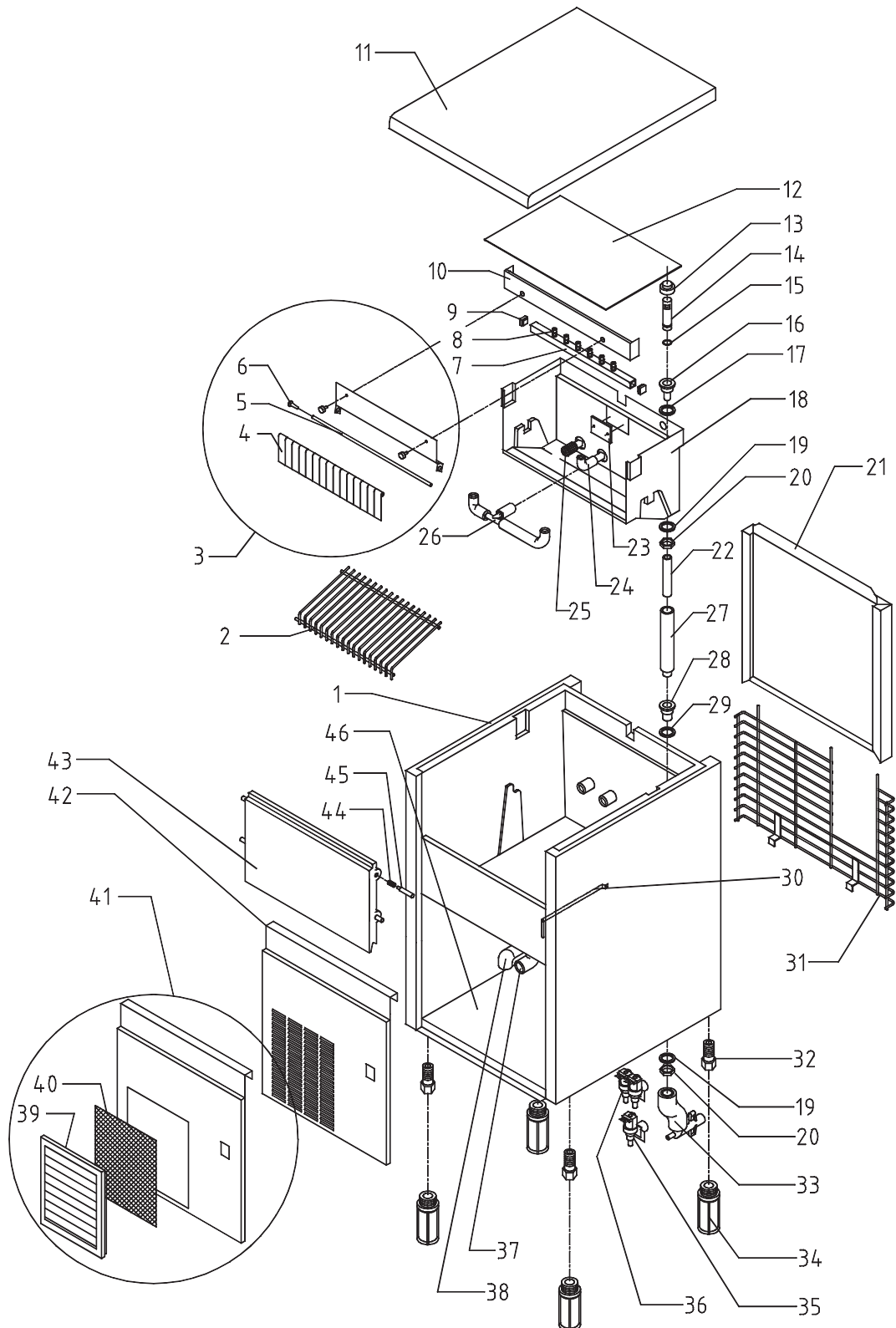

dis. 24489_1

Shell assembly + Hydraulic circuit Mod. CB640-840 A/W – (TAB. 9)

Ref.	Description	Refrigerant	A/W	Tension	Code
1	Foamed cabinet assy				C11009
2	Ice cubes slide				D12017
3	Flags support assy				C22059
4	Flag				10005
5	Flags rod				12016
6	Flags rod clip				10010
7	Sprayers bar assembly				C20058
8	Sprayer				D20002
9	Sprayers bar plug				10012
10	Evaporator holder				22050
11	Top assy				C22673
12	Evaporator cover				10039
13	Overflow cap				10305
14	Overflow tube				10133
15	Or gasket for overflow pipe				20233
16	Overflow pipe nipple				10241
17	Silicone gasket				13006
18	Inner basin				10034
19	Semirigid polyethylene gasket				13007
20	Bin discharge nut				10096
21	Back panel assembly				C22132
22	Overflow pipe				13109
23	Slide keep plate				10009
24	Sprayers feeding pipe				13005
25	Pump suction filter				20005
28	Plastic nipple water outlet				10007
29	Silicone gasket				13006
30	Bulbe thermostat tube				20520
31	Rear grid				D12015
33	Discharges manifold		A		C10006
33	Discharges manifold		W		C26452
34	Foot h.100 mm				10040
35	Inlet watervalue 1 way		A	1-2	23001
35	Inlet watervalue 1 way		A	3	23260
36	Inlet watervalue 2 ways		W	1-2	23010
36	Inlet watervalue 2 ways		W	3	23261
37	Pump suction pipe				13015
38	Pump delivery pipe				13016
39	Grid+frame				C10205
40	Filtering panel				18106
41	Front grid panel				C22509
43	Door				10275
44	Door pin spring				20499
45	Door pin				10269
46	Base plate				C21036

Note: 13. Code 10305 from number 62740.
14. Code 13017 until number 62739. Code 10133 from number 62740.
15. Code 20233 from number 62740.
22. Code 13017 until number 62739. Code 13109 from number 62740.
30. Code 20008 until number 94414. Code 20520 from number 94415.
41. Code 22049 until number 28697. Code C22509 from number 28698.

Cooling system assembly Mod. CB640-840-955-1265-1565 A/W

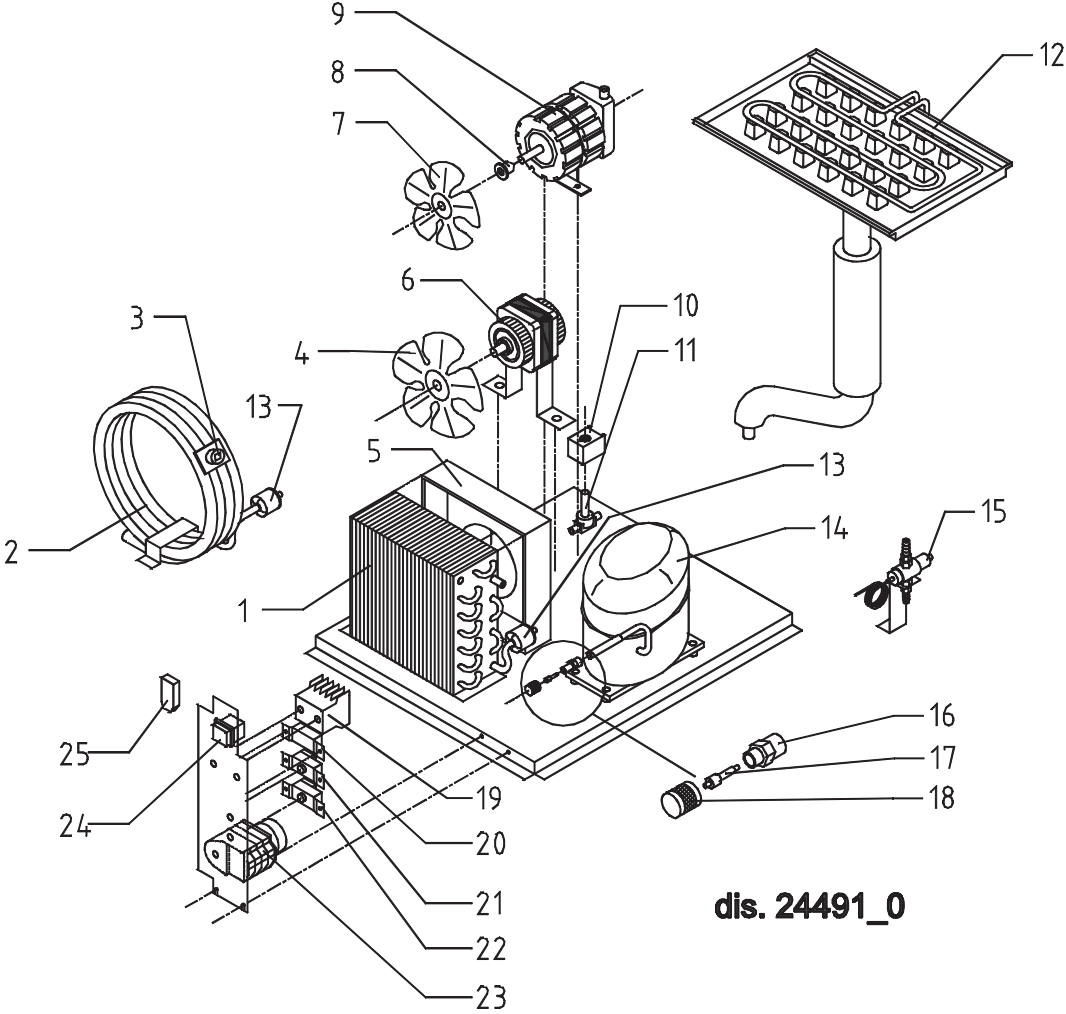

dis. 24491_0

Cooling system assembly Mod. CB640 A/W – (TAB. 18)

Ref.	Description	Refrigerant	A/W	Tension	Code
1	Air condenser		A		20175
2	Water condenser		W		14034
3	Safety thermostat		W		C23114
4	Suction fan 254/31°		A	2	20031
4	Suction fan 254/31°		A	1-3	20031
4	Suction impeller		W		10213
6	Lower fan motor		A	1	23067
6	Lower fan motor		A	2	23580
6	Fan motor		A	3	23393
6	Fan motor		W	1-2	23029
6	Fan motor		W	3	23265
7	Suction impeller				10213
8	Hub+washer+screw				10014
9	Pump			1-2	23002
9	Pump			3	23264
10	Hot gas coil			1-2	23091
10	Hot gas coil			3	23256
11	Hot gas valve body				20410
12	Evaporator				D10047
13	Solid core drier				14089
14	Compressor	R404A		1	23505
14	Compressor	R404A		2	23578
14	Compressor	R404A		3	23579
14	Compressor	R22		1	23292
14	Compressor	R22		2	23347
14	Compressor	R22		3	23371
16	Vacuum- charge valve body				14007
17	Vacuum-charge valve device				14005
18	Vacuum-charge valve plug				14006
19	Contacteur	R22		3	23390
20	Condenser pressure switch				23175
21	Bin thermostat				23005
22	Evaporator thermostat				23591
23	Timer			1	23222
23	Timer			2	23248
23	Timer			3	23259
24	Green light switch				23327
25	Anti radio interference filter		A	1	23459
25	Anti radio interference filter		W	1	23457

Note: 2. Code 14014 (W) until number 28567. Code 14034 (W) from number 28568.
 4. Code 20052 (A, Tens.2) until number 14050. Code 20096 (A, Tens.2) from number 14051 to number 76523.
 Code 20031 (A, Tens.2) from number 76524.
 23. Code 23222 from September 1992. Before Code 23003.