

CME256 or CME506 or CME656 or CME806 Service Parts

This parts list contains service part information for 8 basic models, plus 4 different electrical configurations. **The complete model number will be needed to identify the correct part.**

Model Series Changes (code at end of model number)

- C series - changes to the front & side panels
- D series - changes to the top panel and to the compressor starting components
- E series - new side panels and 2 TXVs with check valves for the CME506
- F series - new water cooled condensers
- H series - color change

Electrical Codes are located at the end of the model number (voltage/hertz/phase):

- -1 is 115/60/1
- -32 is 208-230/60/1
- -3 is 208-230/60/3
- -6 is 250/50/1

Electrical Components Common to All Machines:

- Inlet water valve
- Water sensor
- Discharge line sensor
- Controller
- Ice sensor/bin controls
- Water level sensor

Unique Electrical Components

- Compressor and related starting components
- Contactor (single / three phase)
- Fan motor
- Water pump
- Transformer
- Hot gas valve

Other Unique parts include: side panels, electrical, refrigeration and some water system items.

TABLE OF CONTENTS

Cabinet	PAGE 2	A - C Series CME256 and CME506 Air Cooled Wiring Diagram	PAGE 24
Interior Structure & Controls	PAGE 3	A - C Series Water Cooled Single Phase Schematic Diagram	PAGE 25
CME256 Air Cooled Refrigeration	PAGE 4	A - C Series CME256 and CME506 Water Cooled Wiring Diagram	PAGE 26
CME506 A - D Series Air Cooled Refrigeration	PAGE 5	A - C Series CME656 or CME806 Air Cooled Single Phase Wiring Diagram	PAGE 27
CME506 E - H Series Air Cooled Refrigeration	PAGE 6	A - C Series CME656 Water Cooled Single Phase Wiring Diagram	PAGE 28
CME656 Air Cooled Refrigeration	PAGE 7	A - H Series Three Phase Air Cooled Schematic Diagram	PAGE 29
CME806 Air Cooled Refrigeration	PAGE 8	A - C Series CME656 Air Cooled Three Phase Wiring Diagram	PAGE 30
Water System Components	PAGE 9	A - H Series CME656 Three Phase Water Cooled Schematic Diagram	PAGE 31
CME256 Water Cooled Refrigeration	PAGE 10	A - C Series CME656 Three Phase Water Cooled Wiring Diagram	PAGE 32
CME506 A - D Series Water Cooled Refrigeration	PAGE 11	D thru H Series CME506 50 Hz Air Cooled Diagram	PAGE 33
CME506 E - H Series Water Cooled Refrigeration	PAGE 12	D thru H Series CME506 50 Hz Water Cooled Diagram	PAGE 34
CME656 Water Cooled Refrigeration	PAGE 13	D thru H Series CME656 or CME806 50 Hz Air Cooled Diagram	PAGE 35
CME806 Water Cooled Refrigeration	PAGE 14	D thru H Series CME656 or CME806 50 Hz Water Cooled Diagram	PAGE 36
Compressors and Electrical Components for CME256 and CME506	PAGE 15	B or C Series 50 Hz Water Cooled CME506 Diagram	PAGE 37
Compressors and Electrical Components for CME656 and CME806	PAGE 16	B or C Series, 50 Hz Air Cooled CME656 and CME806 Diagram	PAGE 38
HTB555 Ice Storage Bin	PAGE 17	B or C Series, 50 Hz Water Cooled CME656 and CME806 Diagram	PAGE 39
D thru H Series Single Phase 60 Hz Schematic Diagram	PAGE 18	B or C Series, 50 Hz Air Cooled CME506 Diagram	PAGE 40
D thru H Series, 115 volt CME256 and CME506 Wiring Diagram	PAGE 19	D thru H Series, 50 Hz CME256 Diagram	PAGE 41
D thru H Series CME656 or CME806 Single Phase Wiring Diagram	PAGE 20		
D thru H Series CME656 Three Phase Wiring Diagram	PAGE 21		
D thru H Series, 230 volt, 60 Hz. CME256 and CME506 Diagram	PAGE 22		
A - C Series Single Phase Air Cooled Schematic Diagram	PAGE 23		

CME256 or CME506 or CME656 or CME806 Service Parts

Cabinet

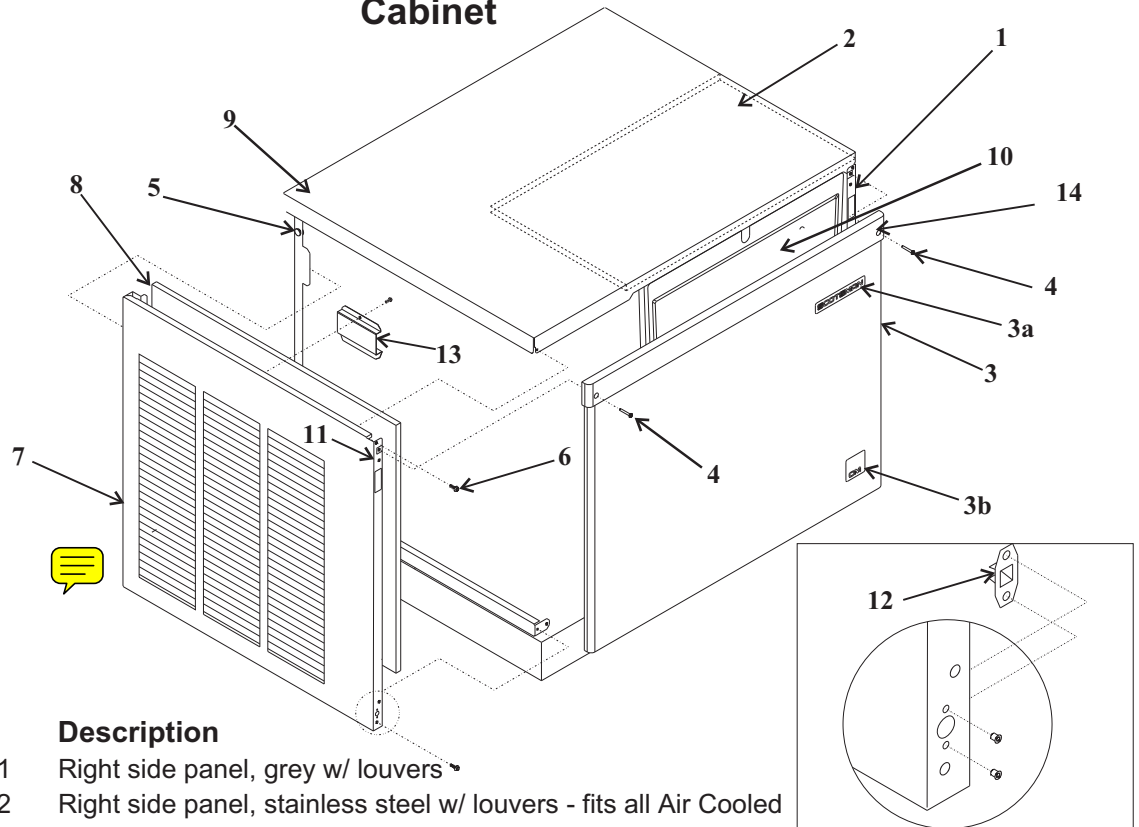

Item Number	Part Number	Description	
1	A35963-021	Right side panel, grey w/ louvers	
	A35963-022	Right side panel, stainless steel w/ louvers - fits all Air Cooled	
	A37071-021	Right side panel, painted w/out louvers (water cooled only)	
	A37071-022	A - D series right side panel, stainless steel without louvers (water cooled only)	
	A38126-021	E - H series right side panel, w/out louvers for water cooled only	
2	02-3659-01	Top insulation	
	02-3797-21	C series Front panel kit, gray plastic , includes trim strip & emblems	
3	03-1733-01	Strike (for C to H series panel, SS or plastic)	
	A37167-001	Front panel kit, SS, replaces gray plastic or SS, includes item 10a (for A series)	
	A37488-031	C to H series Front panel kit, stainless steel , includes trim strip & emblems	
3a	15-0808-01	Emblem for ss panel (Scotsman); 03-0271-00 is the speed nut for emblem	
3b	15-0792-02	Emblem for C to H series front panel, (CM ³)	
4	03-1735-01	Screw for trim strip (for C to H series)	
	03-1404-12	Sheet metal screw for plastic front panel (for A series)	
	03-1419-22	Sheet metal screw for ss front panel	
5	02-1875-03	Panel bumper/hole plug	
	03-1531-01	Sheet metal screw	
7	A35962-021	Left side panel, grey enamel with louvers	
	A35962-022	Left side panel, stainless steel with louvers	
	A37070-021	Left side panel, grey enamel without louvers (water cooled only)	
	A37070-022	A - D series left side panel, stainless steel without louvers (water cooled only)	
	A38127-021	E - H series left side panel, w/out louvers for water cooled only	
8	02-3485-01	Air filter, air cooled only	
	A35965-001	Top panel, grey enamel, order item 2 also	
	A35965-002	Top panel, stainless steel, order item 2 also	
	02-3822-21	Top panel, plastic, fits all, original to H series	
10a	02-3663-01	Evaporator cover, use began Feb. 1997. Fits A and B series	
	02-3796-01	Insulation for above cover	
	02-3663-20	Evap cover w/ ins for C - H series	
11	03-1423-06	Speed nut for panel screws	
12	03-1733-02	Catch	
	13	A37326-001	Filter bracket
	14	02-3794-31	Trim strip.
			03-1731-02 is the push nut for trim strip

CME256 or CME506 or CME656 or CME806 Service Parts

Interior Structure & Controls

Note: Item 25 mounts to Item 1.
Item 1 must have rectangular mounting tabs. All units after 9/96 were mfg. with rectangular tabs.

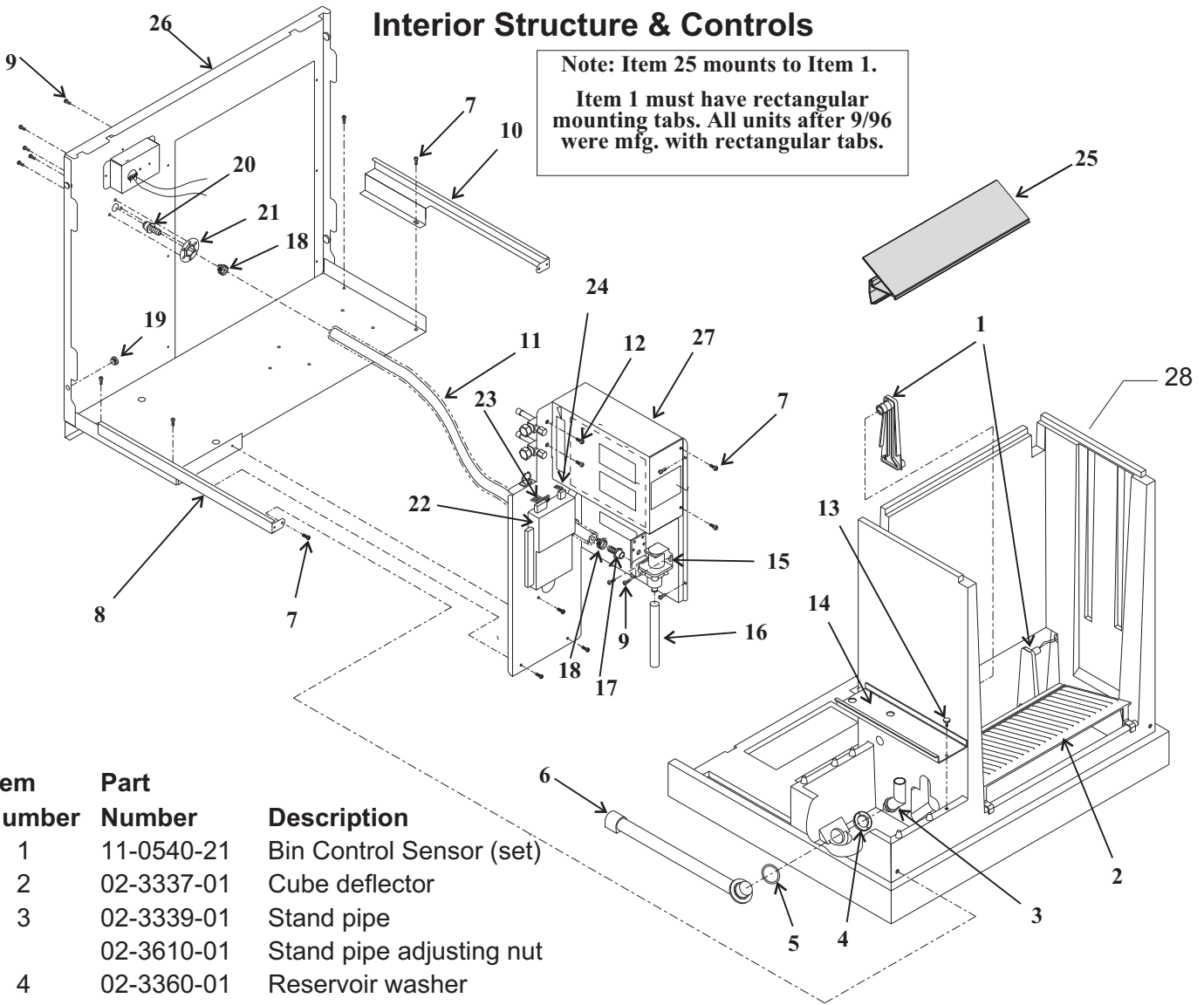

Item Number	Part Number	Description
1	11-0540-21	Bin Control Sensor (set)
2	02-3337-01	Cube deflector
3	02-3339-01	Stand pipe
	02-3610-01	Stand pipe adjusting nut
4	02-3360-01	Reservoir washer
5	13-0617-56	O-ring
6	02-3338-01	Drain tube & fittings
7	03-1404-18	Screw
8	A36298-001	Left side channel
9	03-1531-01	Screw
10	A36297-001	Right side channel
11	13-0906-01	Plastic inlet water hose, 21" req. order 2 units - not used after Sept. 1996
12	03-1645-01	Screw
13	03-1691-01	Nylon screw
14	02-3340-01	Reservoir cover
15	12-2548-01	Inlet water valve
16	13-0674-02	Tubing, 9" req., order 1 unit
17	02-3443-01	Water fitting for hose
	16-1020-01	Water fitting for copper
18	02-0179-05	Clamp
19	13-0903-01	Bumper for side panels
	20	16-0997-01 Inlet water fitting for hose
		16-1019-01 Inlet water fitting for copper
	21	16-0701-07 Mounting flange
	22	12-2838-23 AutoIQ controller
	23	12-2644-21 Low voltage harness A - C series
		12-2782-21 Low volt harness, D + series 60 Hz
		12-2782-23 Low volt harness, D + series 50 Hz
	24	12-2618-01 Hi volt harness, w fan control A series
		12-2476-01 Hi volt harness for w/o fan control A-C
		12-2678-01 Hi volt harness for 50 Hz models A-C
		12-2784-21 Hi volt harness for D + series 60 Hz.
		12-2786-21 Hi volt harness for D + series 50 Hz.
	25	02-3657-01 Cascading shield, used on CME806, 656 and 506 after 2/97
	26	A36460-001 Back panel assy (ac)
		A36460-003 Back panel assy (wc)
	27	A35959-001 Hi voltage box cover
	28	A36457-001 Foamed base

CME256 or **CME506** or CME656 or CME806 Service Parts

CME506 A - D Series Air Cooled Refrigeration

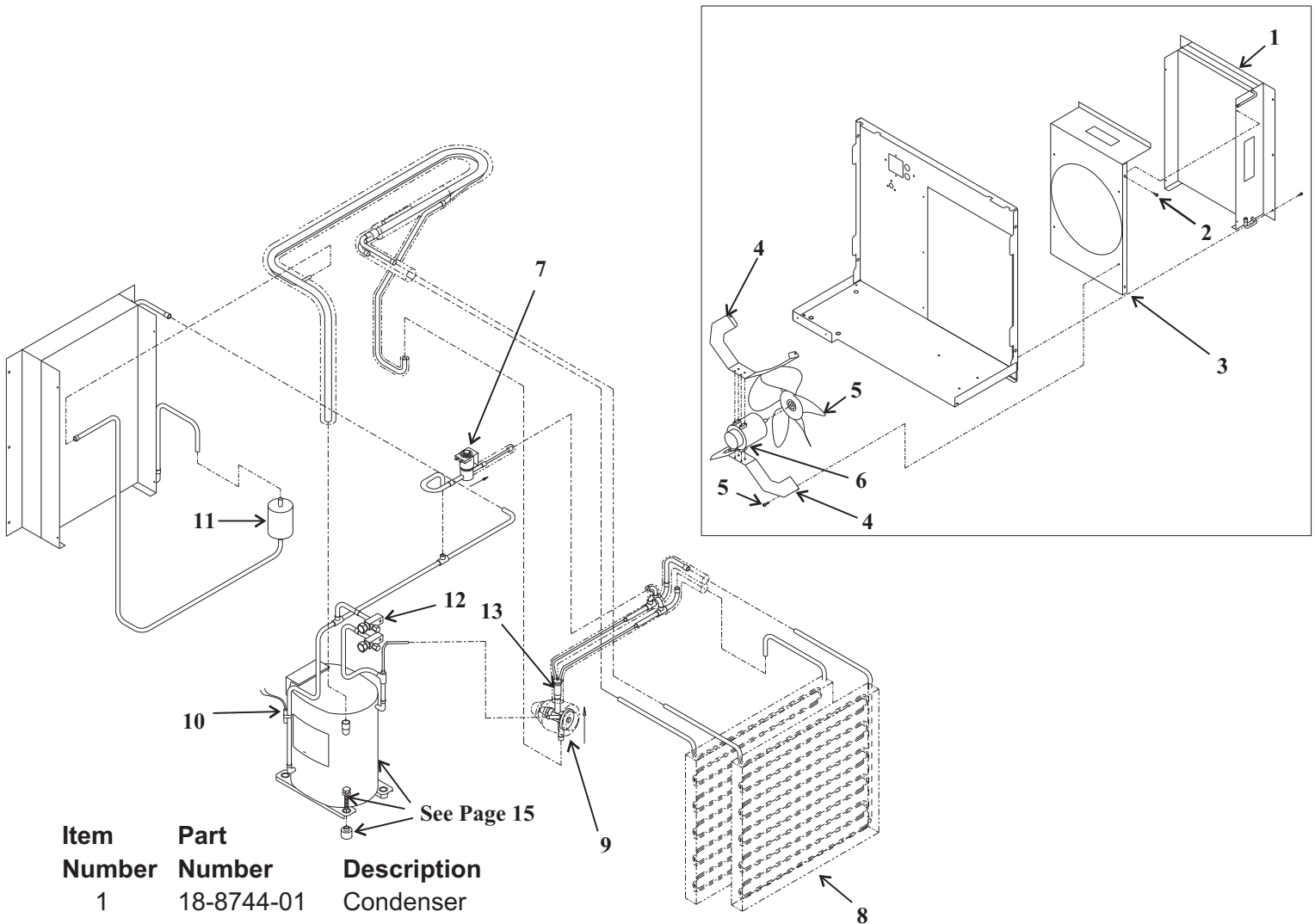

Item Number	Part Number	Description	
1	18-8744-01	Condenser	
2	03-1531-01	Screw	
3	A35967-001	Shroud	
4	A36668-001	Motor bracket	
5	18-8503-01	Fan blade	
6	18-5505-01	Fan motor for 115 volt, 60 Hz.	
	18-5505-12	Fan motor for 230 volt, 50 Hz.	
	18-5505-11	Fan motor for 230 volt, 60 Hz	
7	12-2471-22	Hot gas valve w/coil	
	12-2719-23	Hot gas valve coil only	
8	A36734-020	Evaporator	
9	16-1017-21	TXV (was 16-0867-21, they are interchangeable)	
	02-4406-01	Insulation for TXV	
10	02-3410-21	Temp. sensor, includes water temp. & clip	
11	02-3319-02	Dryer	
12	16-0832-21	Access valve	
12a	16-0832-03	Port cap	
12b	16-0832-02	Stem cap	
	13	16-0843-03	Distributor assembly
	14	16-1063-01	Hot gas valve strainer (not shown)

For models with a fan control switch:
The part number of the fan control pressure switch is: 11-0508-21

CME256 or **CME506** or CME656 or CME806 Service Parts

CME506 E - H Series Air Cooled Refrigeration

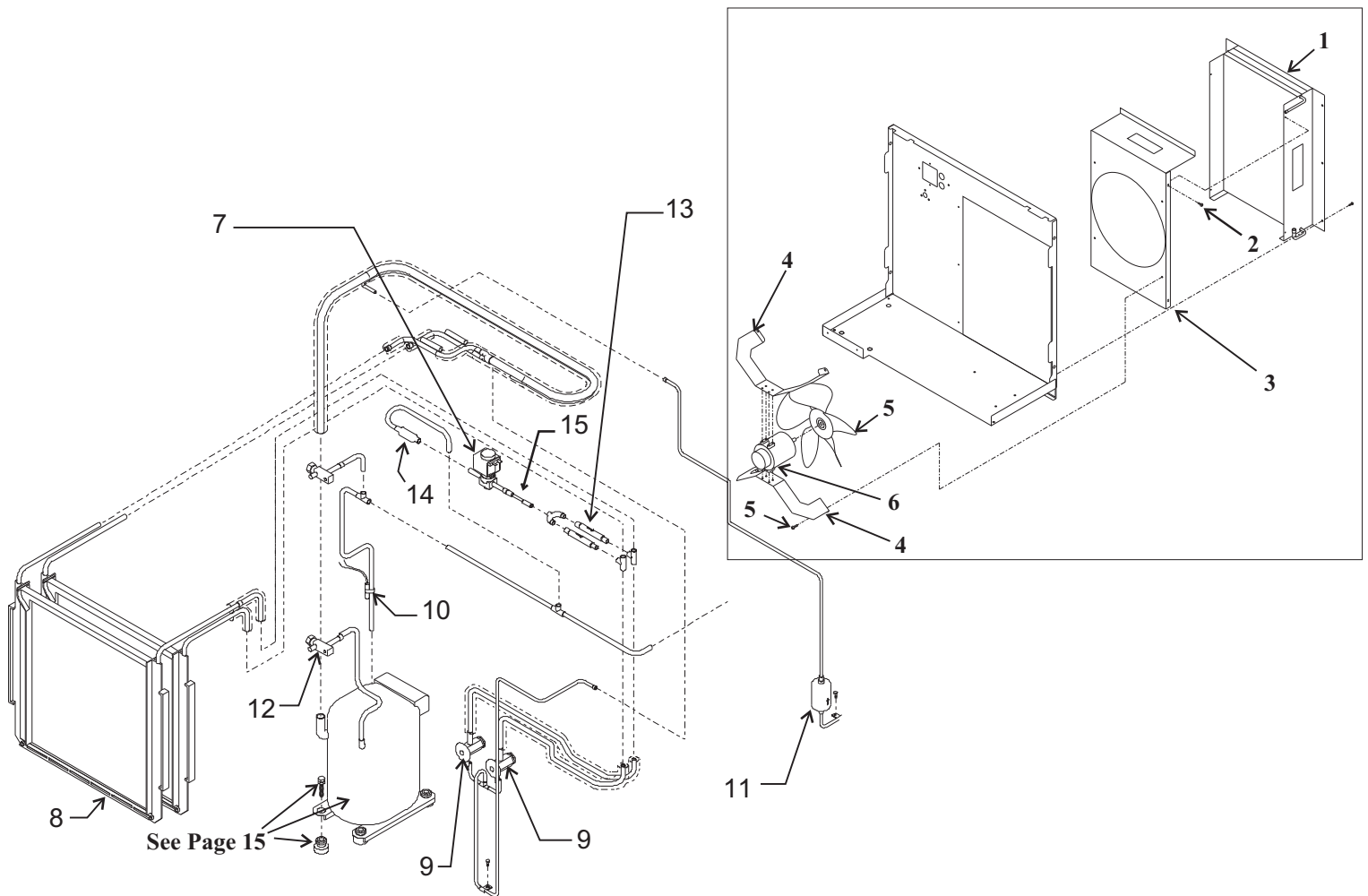

Item Number	Part Number	Description	Item Number	Part Number	Description
1	18-8866-02	Condenser - E Series & up	11	02-3319-01	Dryer
2	03-1531-01	Screw	12	16-0832-21	Access valve
3	A35967-001	Shroud	12a	16-0832-03	Port cap
4	A36668-001	Motor bracket	12b	16-0832-02	Stem cap
5	18-8503-01	Fan blade	13	16-1071-01	Check valve
6	18-5505-01	Fan motor for 115 volt, 60 Hz.	14	16-1063-01	Hot gas valve strainer
	18-5505-12	Fan motor for 230 volt, 50 Hz.	15	16-1095-01	Restrictor
	18-5505-11	Fan motor for 230 volt, 60 Hz			
7	12-2471-22	Hot gas valve w/coil			
	12-2719-23	Hot gas valve coil only			
8	A36734-020	Evaporator			
9	16-1009-22	TXV - only for E series & up			
	02-4405-01	Insulation for TXV			
10	02-3410-21	Temp. sensor, includes water temp. sensor. & clip			

CME256 or CME506 or CME656 or CME806 Service Parts

Water System Components

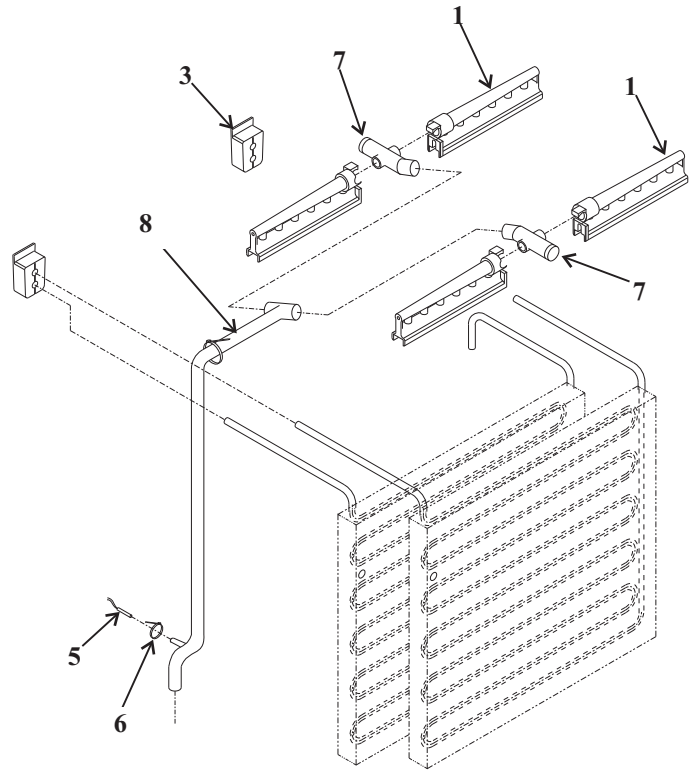
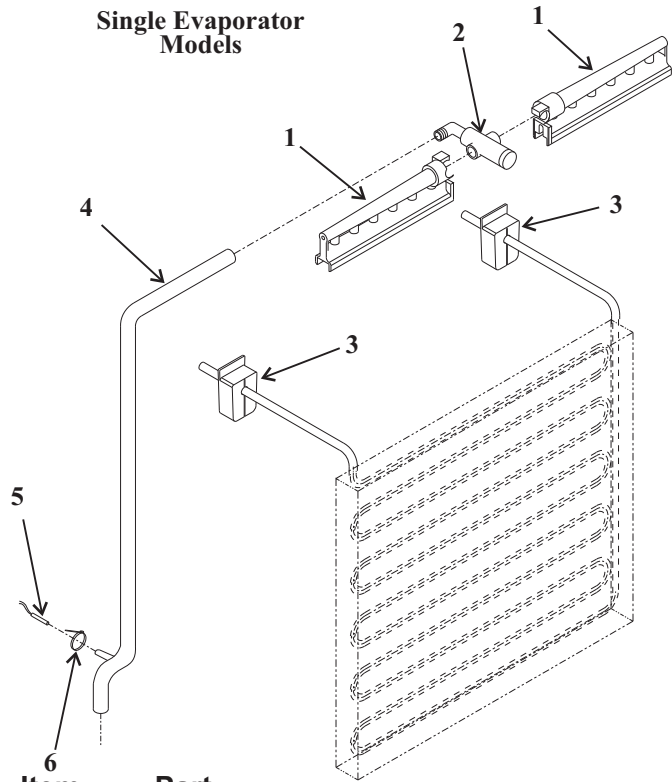

Two Evaporator Models

Item Number	Part Number	Description
1	02-2527-01	Water distributor
2	A30926-001	Distributor manifold
3	13-0898-02	Tubing grommet
4	02-3361-01	Water discharge tube for single evaporator models
5	02-3410-21	Water temperature sensor includes disch. temp. sensor
6	no number	Cable tie
7	02-3405-01	Inlet Tee
8	02-3336-01	Water distributor tube for double evaporator models
9	02-3383-01	Float stem, 1 evaporator model*
	02-3383-02	Float stem, 2 evaporator model*
10	11-0539-51	Float (water level) sensor
11	02-3388-04	Front pump bracket for 12-2586 type pump
12	02-3388-05	Rear pump bracket for 12-2586 type pump
13	12-2506-01	Harness
14	02-3341-01	Float
15	12-2586-21	CME256-1 (115 volt) pump
	12-2586-27	CME506-1 (115 volt) pump
	12-2586-26	CME256-6 or -32 (208-230 volt),
	12-2586-23	CME506-6 or 32 (208-230 volt),
		CME656 or CME806 (208-230 volt) pump. 50 or 60 Hz.

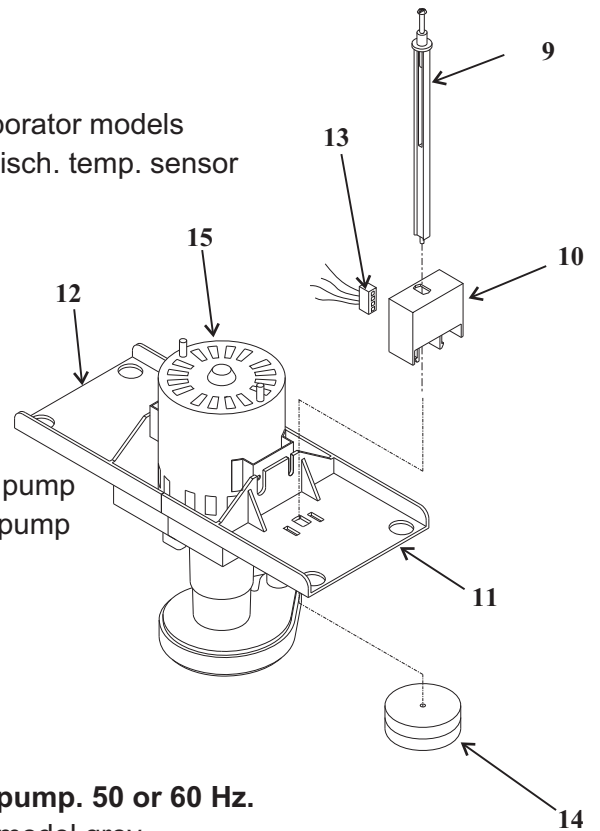

* Not adjustable after 2/97. Then 1 evap model white, 2 evap. model grey.

CME506 A - D Series Water Cooled Refrigeration

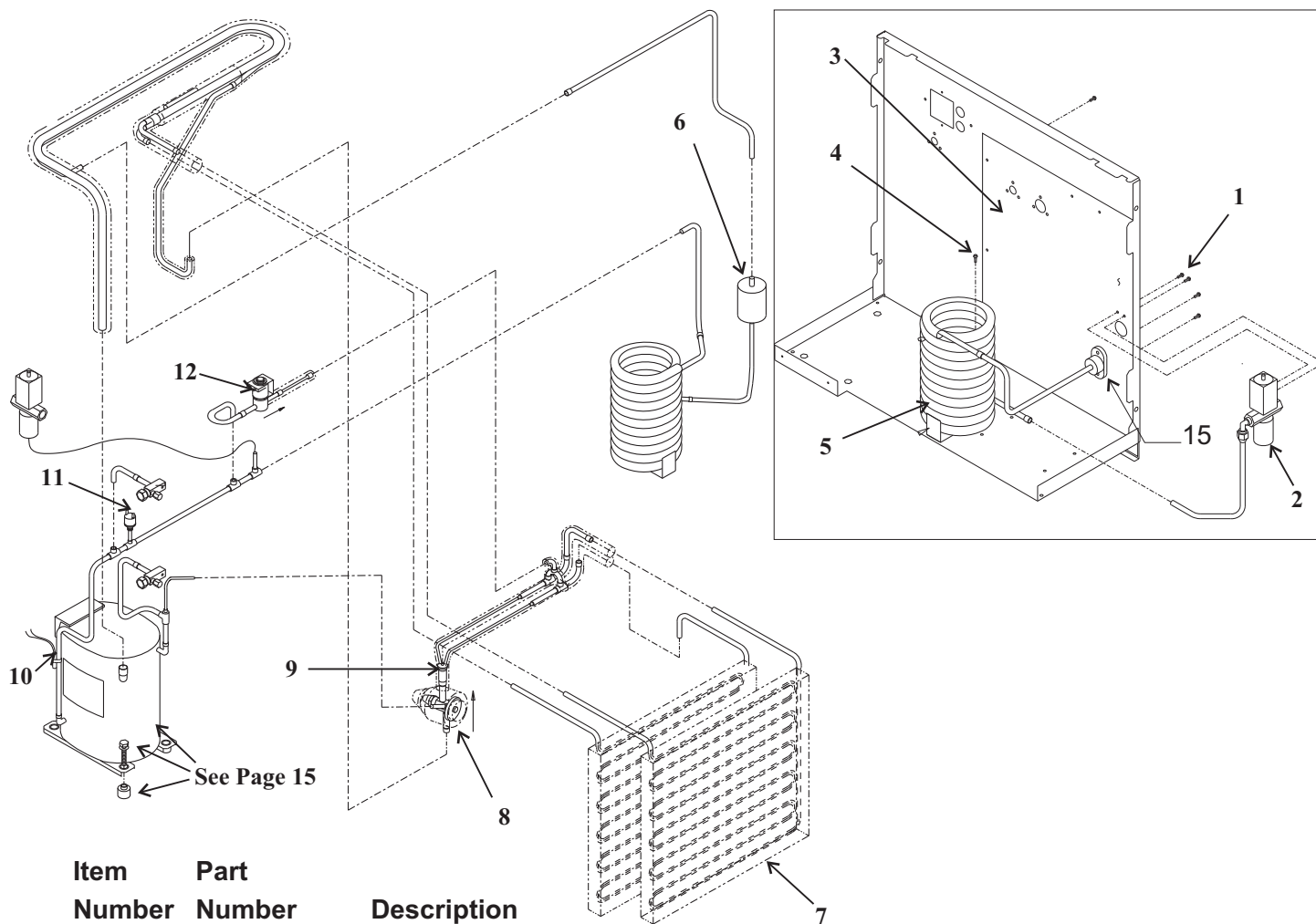

Item Number	Part Number	Description
1	03-1403-15	Screw
2	11-0478-01	Water regulating valve
3	A36440-001	Back cover
4	03-1645-01	Screw
5	18-3306-25	Condenser
6	02-3319-02	Dryer
7	A36734-020	Evaporator
8	16-1017-21	TXV 1/2 ton (was 16-0867-21) For A - D Series only
	02-4406-01	Insulation for TXV
9	16-0843-03	Distributor and tubes
10	02-3410-21	Hi temperature sensor, includes water temperature sensor
	03-1711-01	Clip for sensor
11	11-0501-21	Hi pressure cut out
12	12-2471-22	Hot gas valve w/coil
	12-2719-23	Hot gas valve coil only
13	16-0832-21	Access valve
13a	16-0832-03	Port cap
14	16-1063-01	Hot gas valve strainer, not shown
15	A31828-001	Fitting

CME506 E - H Series Water Cooled Refrigeration

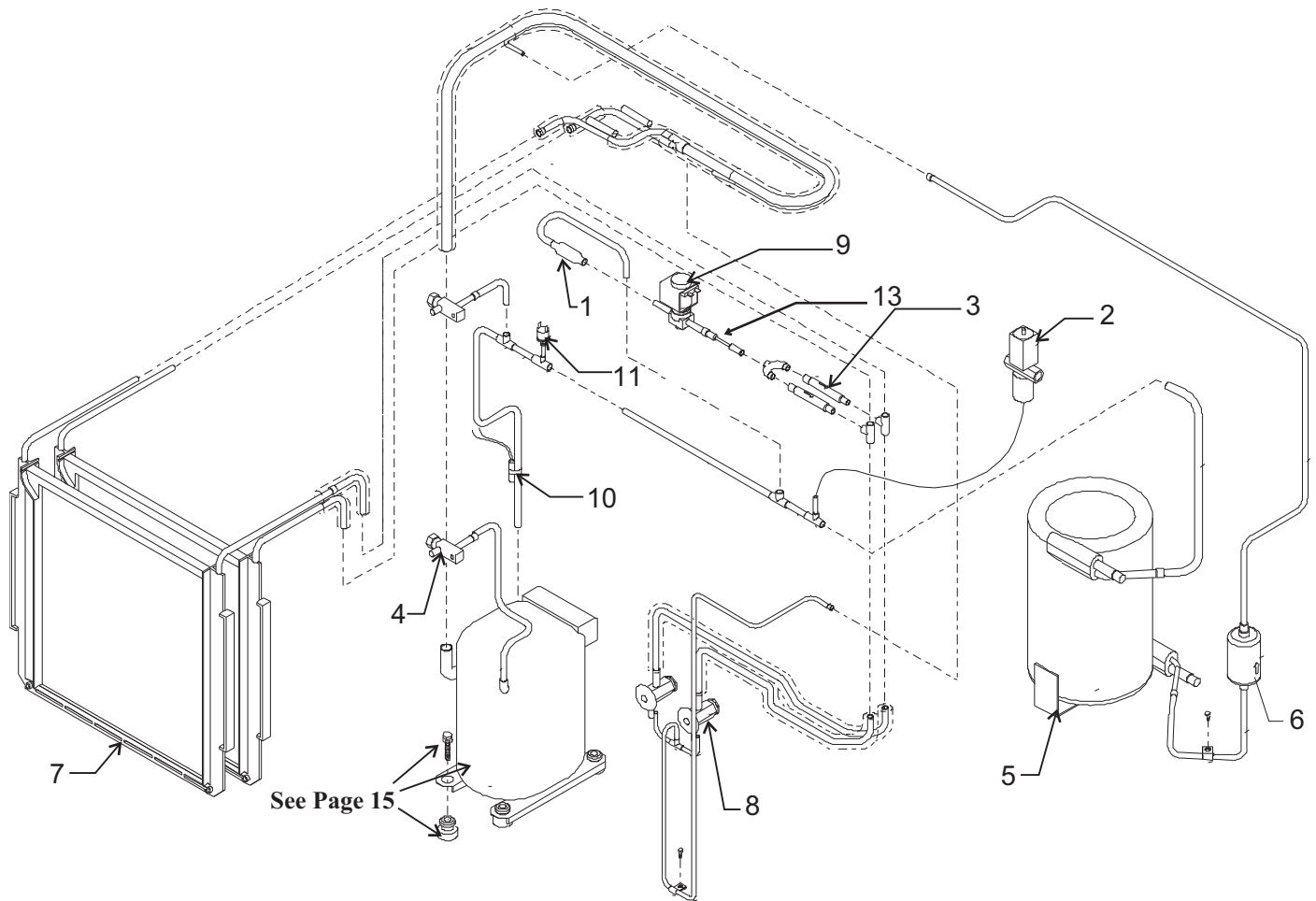

Item Number	Part Number	Description
1	16-1063-01	Hot gas valve strainer
2	11-0478-01	Water regulating valve
3	16-1071-01	Check valve
4	16-0832-21	Access valve
	16-0832-03	Port cap
5	18-3306-25	Condenser, E series
	18-8871-21	Condenser, F & H series
	03-1645-01	Screw to mount condenser (not shown)
6	02-3319-01	Dryer
7	A36734-020	Evaporator
8	16-1009-22	TXV for E Series & up
	02-4405-01	Insulation for TXV
9	12-2471-22	Hot gas valve w/coil
	12-2719-23	Hot gas valve coil only
10	02-3410-21	Hi temperature sensor, includes water temperature sensor
	03-1711-01	Clip for sensor
11	11-0501-21	Hi pressure cut out
12	A31828-001	Fitting
13	16-1095-01	Restrictor

CME256 or CME506 or CME656 or CME806 Service Parts

Compressors and Electrical Components for CME256 and CME506

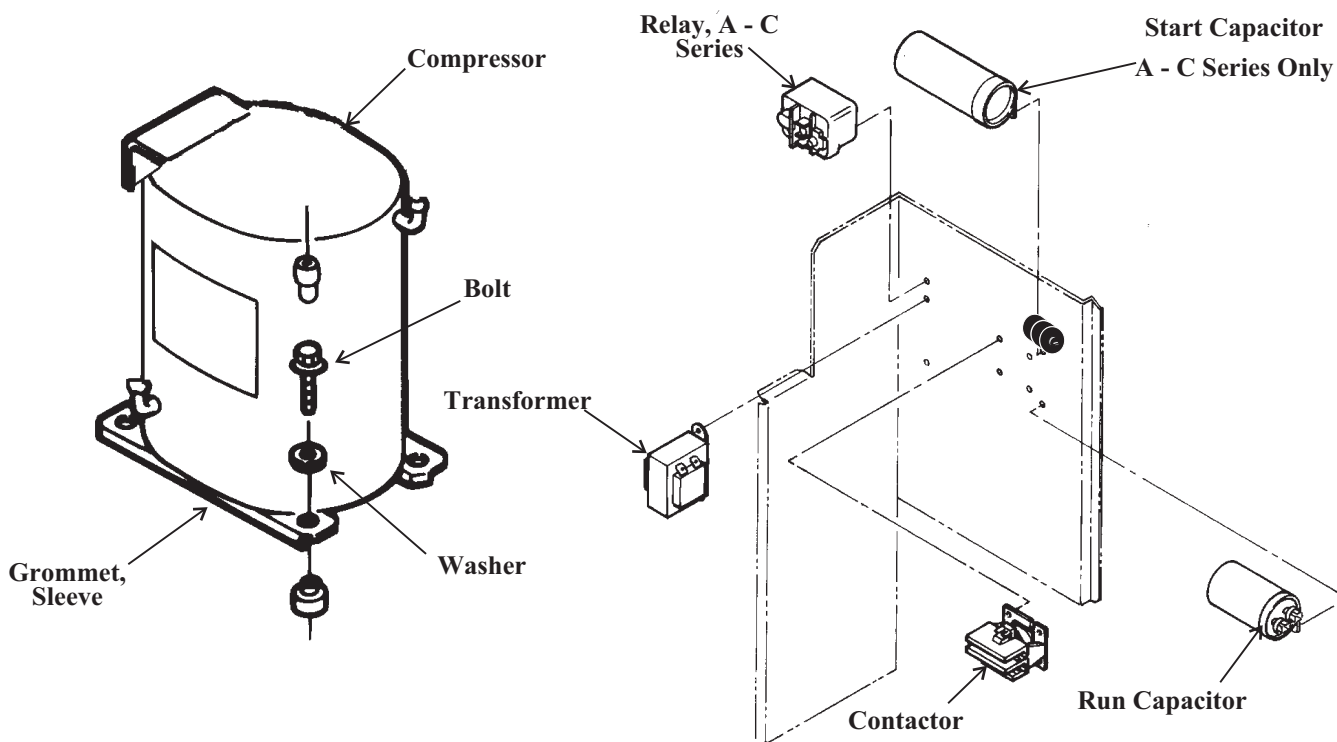

Model	CME256			CME506		
	115/60	208-230/60	230/50	115/60	208-230/60	230/50
Voltage/Hz	115/60	208-230/60	230/50	115/60	208-230/60	230/50
Phase	Single	Single	Single	Single	Single	Single
Compressor	18-8720-21*	18-8838-23*	18-8838-22	18-8721-21*	18-8839-23*	18-8721-22
PTCR - D thru F series only	18-8835-01	18-8835-01	18-8835-01	18-8835-01	18-8835-01	18-8835-01
Start Relay**	18-1903-44	not used	not used	18-1903-50	not used	18-1903-29
Start Capacitor**	18-1901-49	not used	18-2200-35	18-1901-03	not used	18-1901-43
Run Capacitor	18-1902-52	18-1902-17	not used	18-1902-45	18-1902-45	18-1902-30
Overload	18-5700-50	18-8838-50	18-5700-55	18-8711-50	18-8839-50	18-8721-50
Mounting Bolt	03-1405-20	03-1405-20	03-1405-20	03-1405-20	03-1405-20	03-1405-20
Sleeve	18-2200-27	18-2200-27	18-2200-27	18-2200-27	18-2200-27	18-2200-27
Washer	03-1407-07	03-1407-07	03-1407-07	03-1407-07	03-1407-07	03-1407-07
Grommet	18-2200-28	18-2200-28	18-2200-28	18-2200-28	18-2200-28	18-2200-28
Contactora	12-2469-01	12-2469-01	12-2469-01	12-2469-01	12-2469-01	12-2469-01
Transformer	A37231-001	A37217-001	12-2639-02	A37231-001	A37217-001	A37217-001

* Includes starting components. All compressors include a drier. ** D thru F series uses PTCR

-6B, C, D, E, F series	Transformer	Hi Voltage Harness	Fuse	Fuse Block	Relay	Relay Bracket
CME256 or CME506	12-2639-02	12-2678-21	12-2686-01	12-2687-01	12-2679-01	12-2680-01

CME256 or CME506 or CME656 or CME806 Service Parts

HTB555 Ice Storage Bin

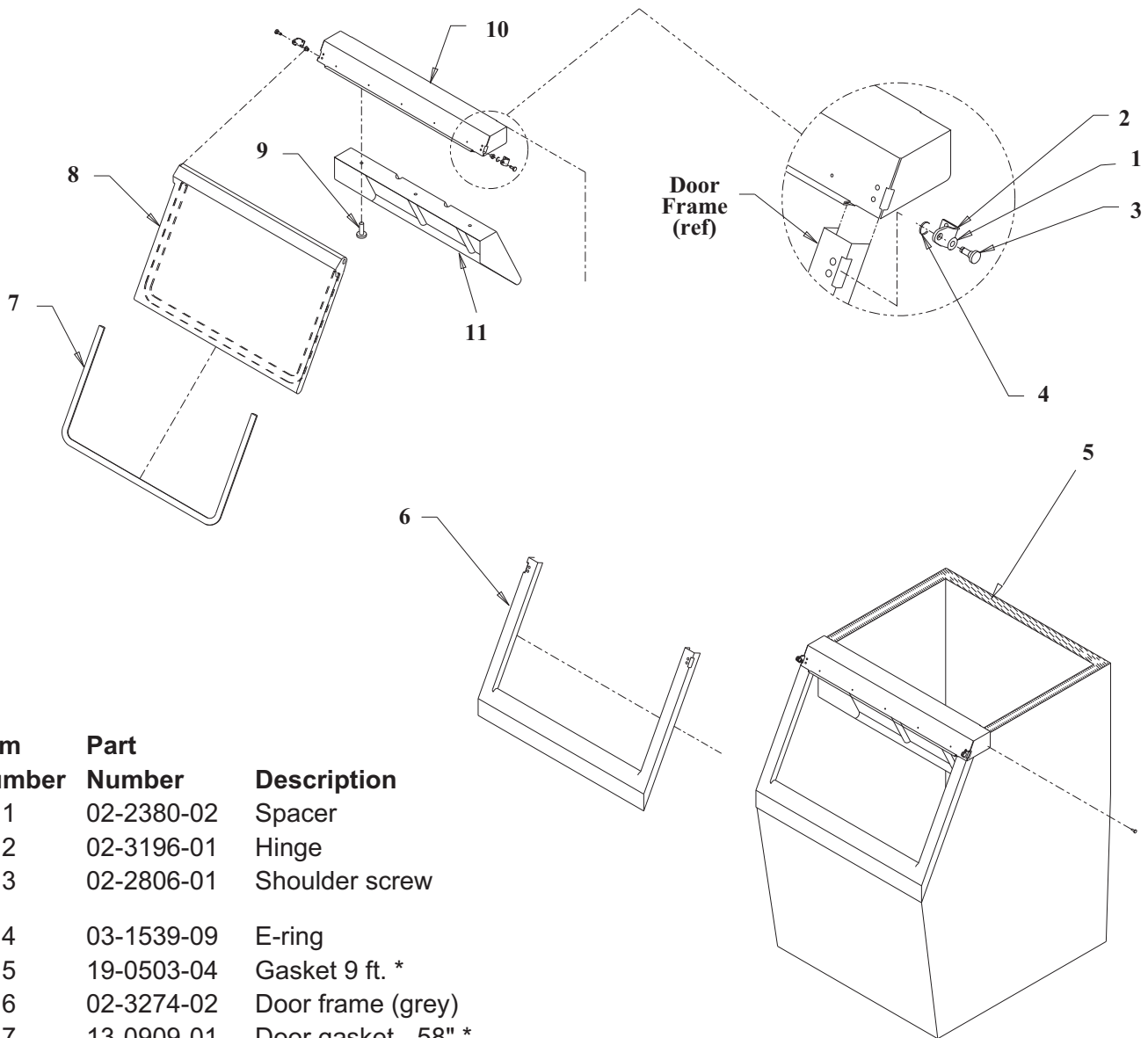

Item Number	Part Number	Description
1	02-2380-02	Spacer
2	02-3196-01	Hinge
3	02-2806-01	Shoulder screw
4	03-1539-09	E-ring
5	19-0503-04	Gasket 9 ft. *
6	02-3274-02	Door frame (grey)
7	13-0909-01	Door gasket - 58" *
8	A36481-022	Door, grey, includes #7.
9	03-0727-11	Thumb screw
10	A35637-001	Canopy
11	A35640-001	Baffle
12	02-2809-02	Drain top
13	13-0617-09	O-ring
14	02-3108-01	Drain bottom

Not shown

- 03-1404-07 Screw for drain bottom
- 05-0586-01 Drain elbow
- 02-0540-00 Scoop
- KLP2E Enamel leg kit

* Order gasket by the foot.
 Optional: A35477-001 Scoop holder, not shown

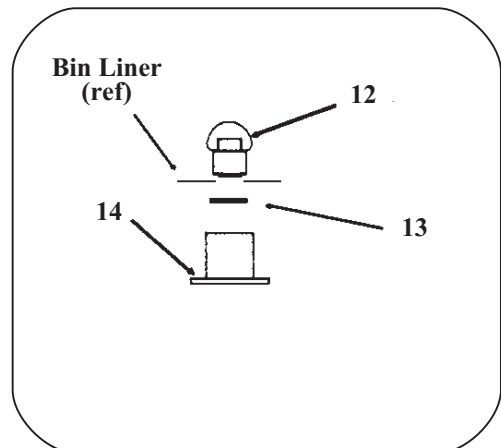

CME256 or CME506 or CME656 or CME806 Service Parts

D thru H Series Single Phase 60 Hz Schematic Diagram

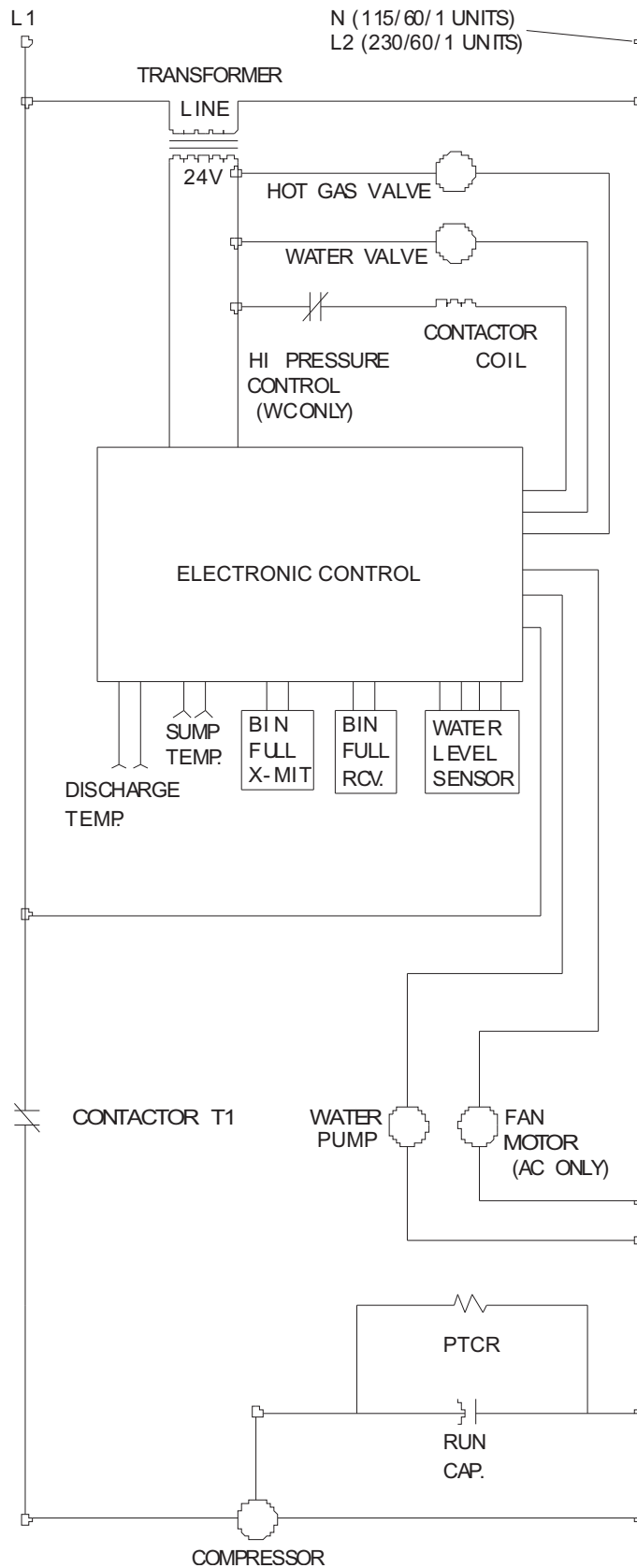

CME256 or CME506 or CME656 or CME806 Service Parts

D thru H Series, 115 volt CME256 and CME506 Wiring Diagram

17-2747-01

USE COPPER CONDUCTORS ONLY

 DASHED LINES INDICATE FIELD WIRING WHICH MUST BE INSTALLED IN ACCORDANCE WITH THE NATIONAL ELECTRICAL CODE AND ALL STATE AND LOCAL CODES.

CAUTION: PTCR WILL BE HOT. COMPRESSOR MAY NOT START IF PTCR IS NOT ALLOWED TO COOL.

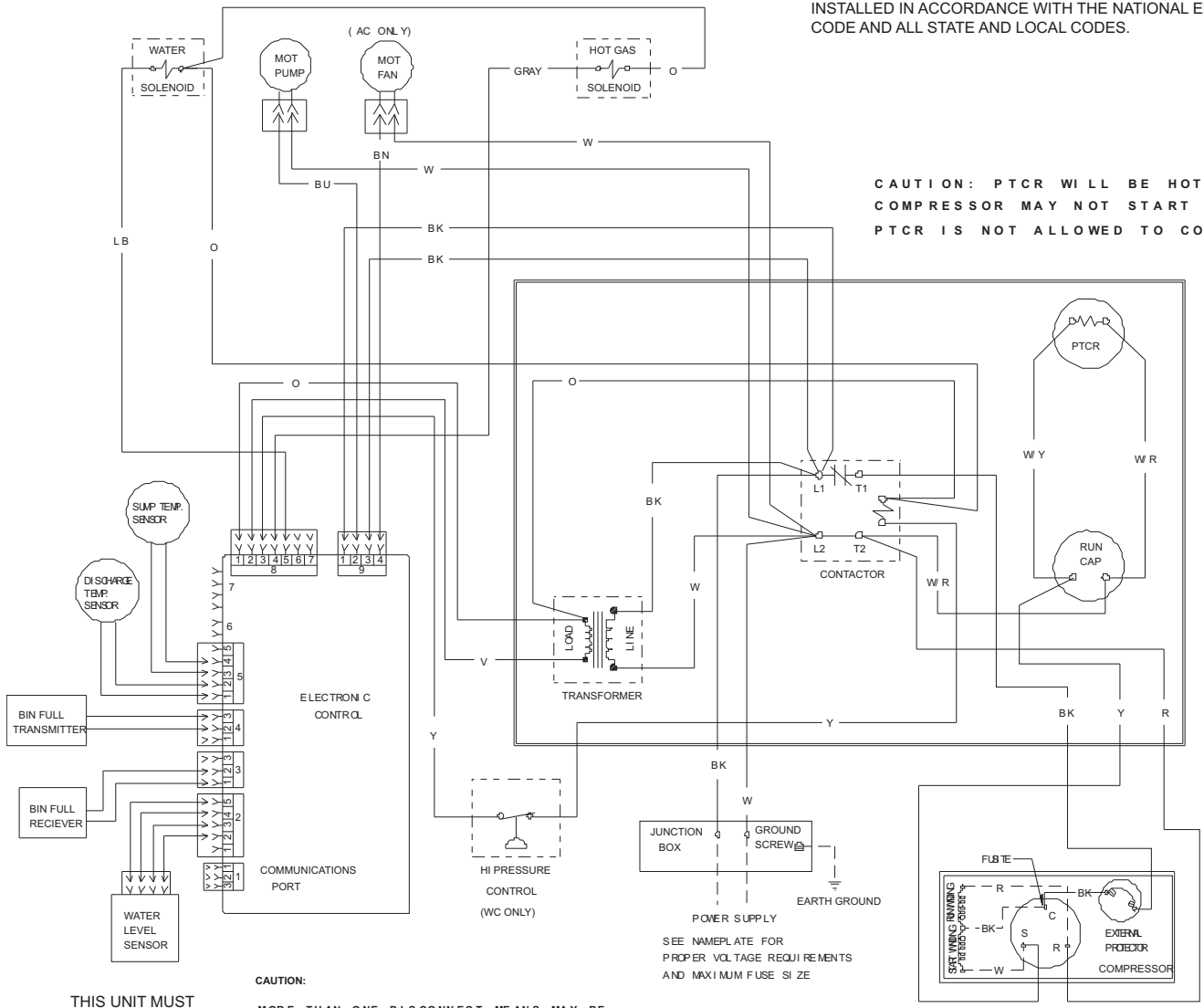

THIS UNIT MUST BE GROUNDED.

CAUTION:
MORE THAN ONE DISCONNECT MEANS MAY BE REQUIRED TO DISCONNECT ALL POWER TO THIS UNIT.

POWER SUPPLY
SEE NAMEPLATE FOR PROPER VOLTAGE REQUIREMENTS AND MAXIMUM FUSE SIZE

D thru H Series, 230 volt, 60 Hz. CME256 and CME506 Diagram

WIRING LINES INDICATE FIELD WIRING WHICH MUST BE INSTALLED IN ACCORDANCE WITH THE NATIONAL ELECTRICAL CODE AND ALL STATE AND LOCAL CODES.

USE COPPER CONDUCTORS ONLY

17-2863-01

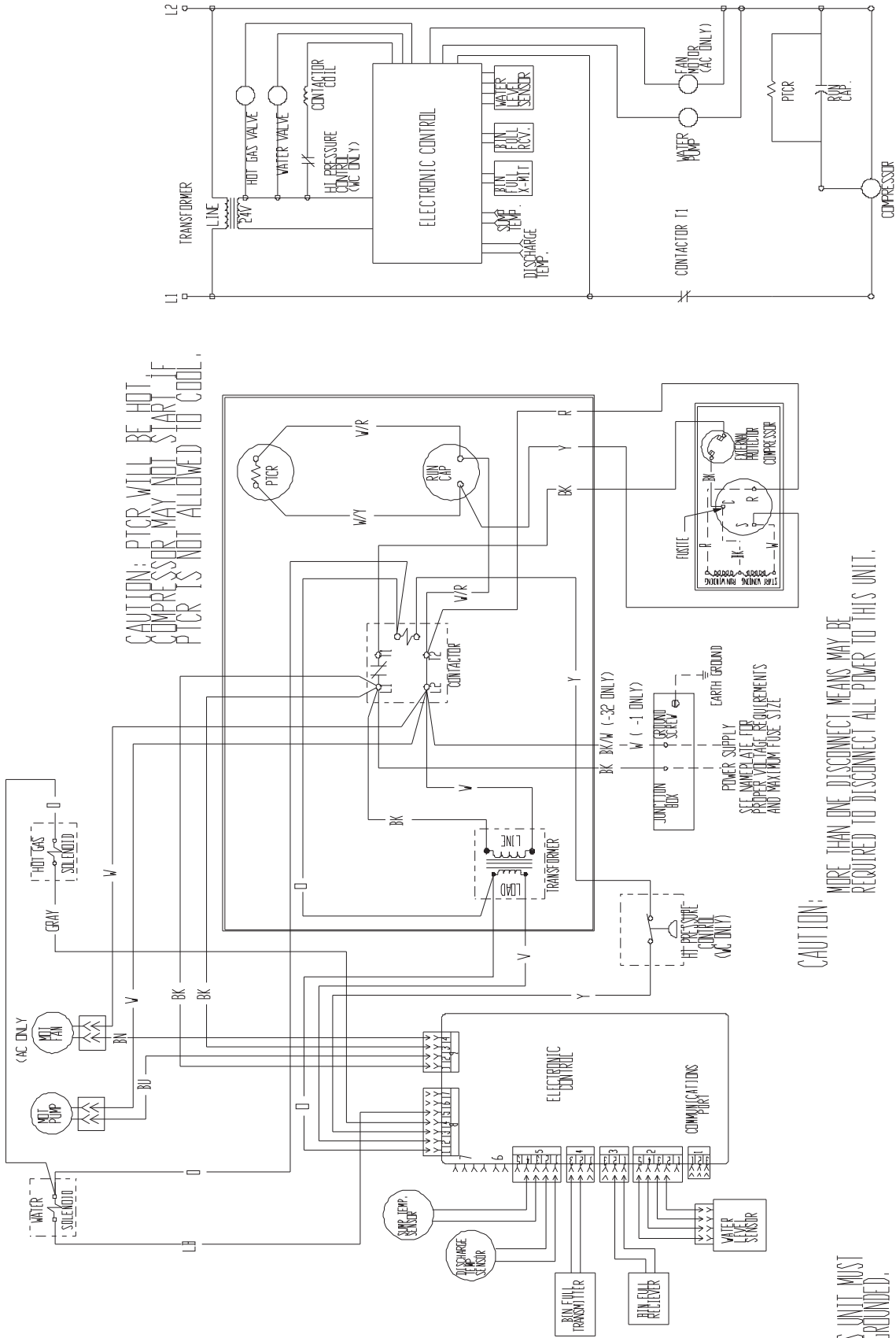

CAUTION: PTCR WILL BE HOT. COMPRESSOR MAY NOT START IF PTCR IS NOT ALLOWED TO COOL.

CAUTION: MORE THAN ONE DISCONNECT MEANS MAY BE REQUIRED TO DISCONNECT ALL POWER TO THIS UNIT.

THIS UNIT MUST BE GROUNDED.

CME256 or CME506 or CME656 or CME806 Service Parts

A - C Series Single Phase Air Cooled Schematic Diagram

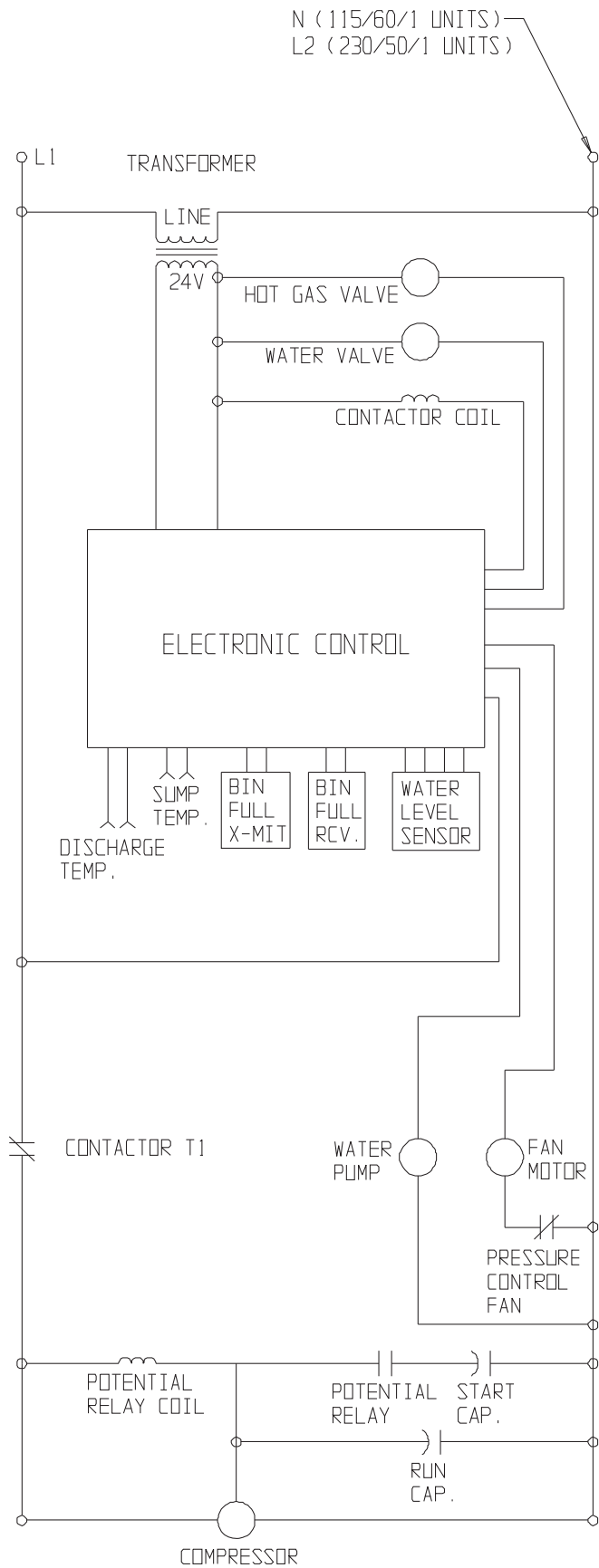

CME256 or CME506 or CME656 or CME806 Service Parts

A - C Series CME256 and CME506 Air Cooled Wiring Diagram

A36991-001

USE COPPER CONDUCTORS ONLY

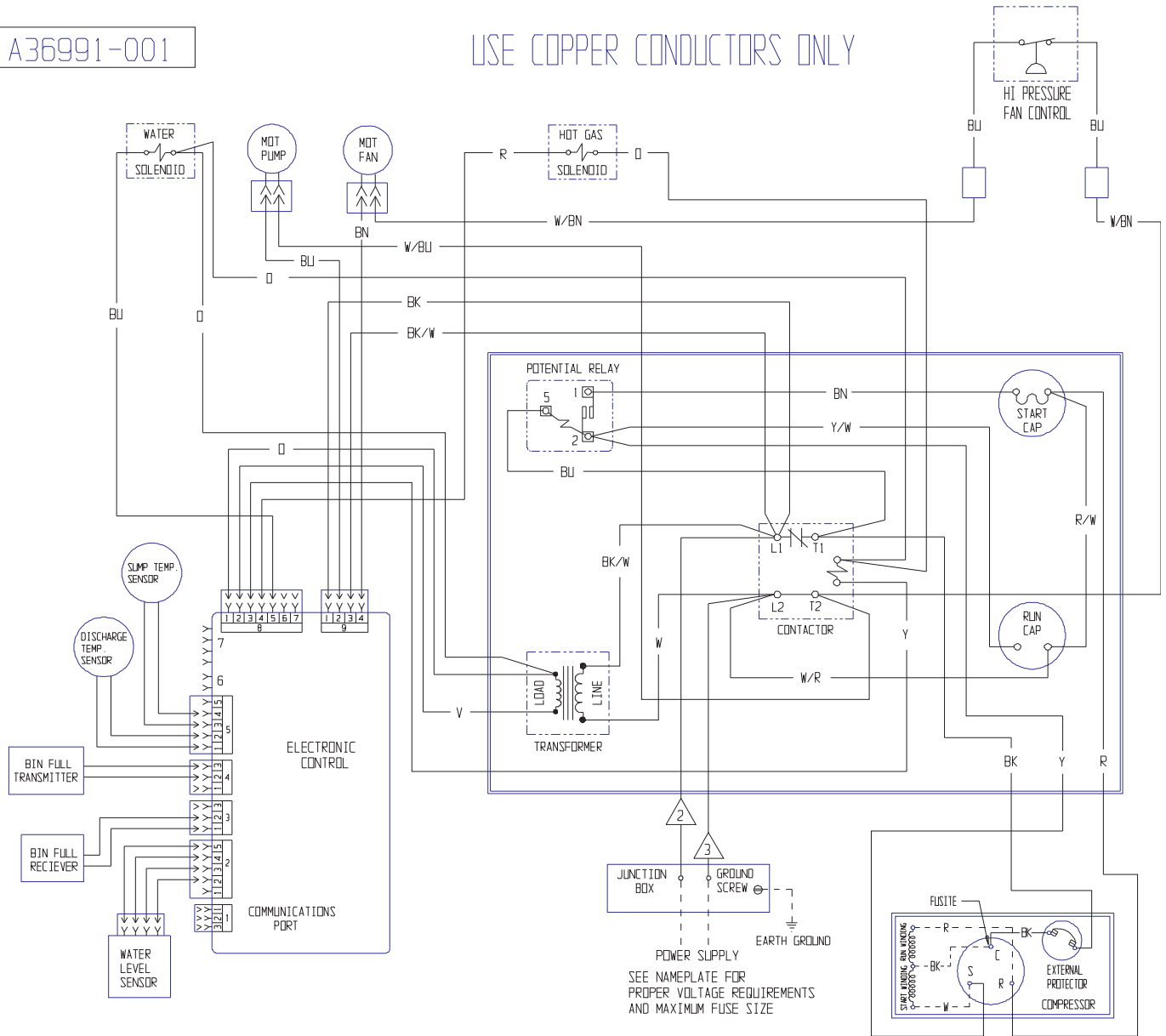

THIS UNIT MUST BE GROUNDED.

CAUTION:

MORE THAN ONE DISCONNECT MEANS MAY BE REQUIRED TO DISCONNECT ALL POWER TO THIS UNIT.

- ⚠ DASHED LINES INDICATE FIELD WIRING WHICH MUST BE INSTALLED IN ACCORDANCE WITH THE NATIONAL ELECTRICAL CODE AND ALL STATE AND LOCAL CODES.
- ⚠ WIRE COLOR FOR 115/60/1 UNITS: BLACK
WIRE COLOR FOR 230/50/1 UNITS : BROWN
- ⚠ WIRE COLOR FOR 115/60/1 UNITS: WHITE
WIRE COLOR FOR 230/50/1 UNITS : BROWN

A - C Series Water Cooled Single Phase Schematic Diagram

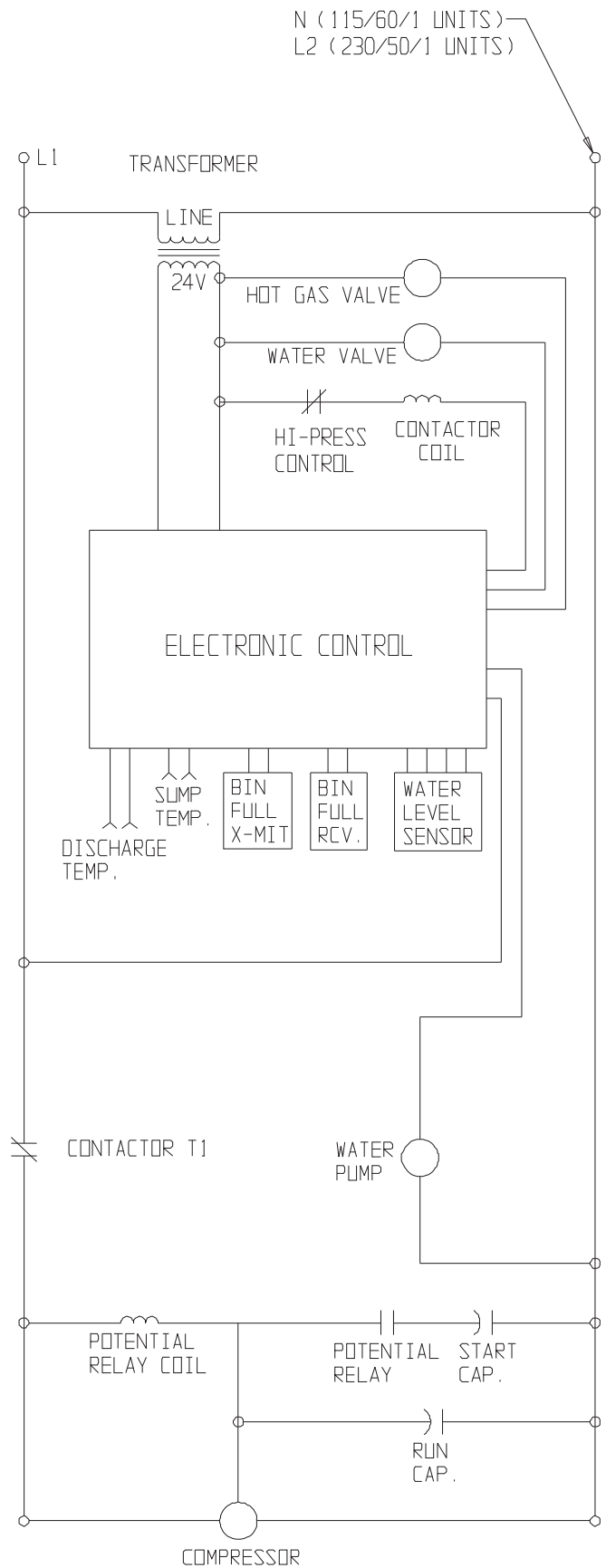

CME256 or CME506 or CME656 or CME806 Service Parts

A - C Series CME256 and CME506 Water Cooled Wiring Diagram

A36670-001

USE COPPER CONDUCTORS ONLY

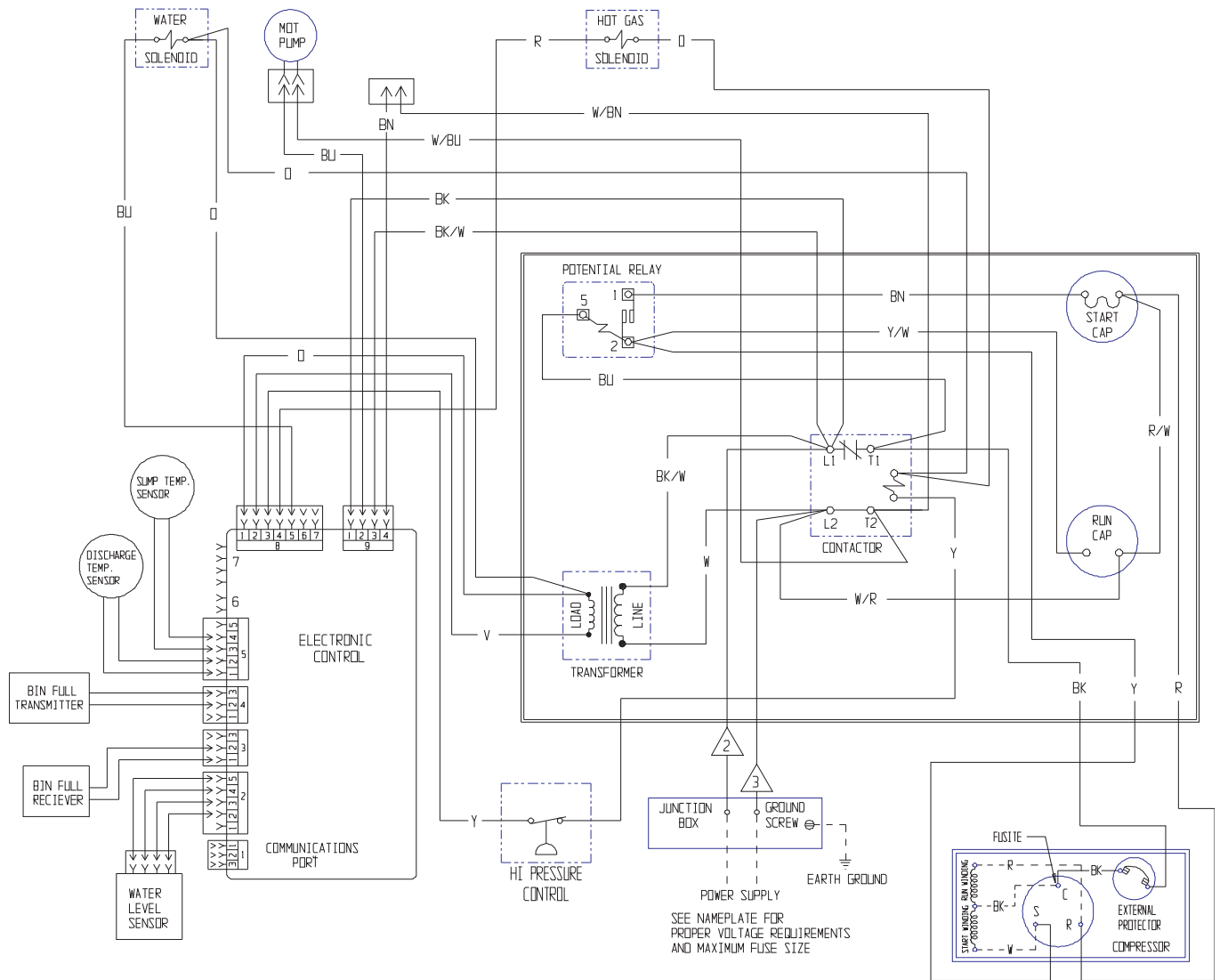

CAUTION:
MORE THAN ONE DISCONNECT MEANS MAY BE
REQUIRED TO DISCONNECT ALL POWER TO THIS UNIT.

THIS UNIT MUST
BE GROUNDED.

A - H Series Three Phase Air Cooled Schematic Diagram

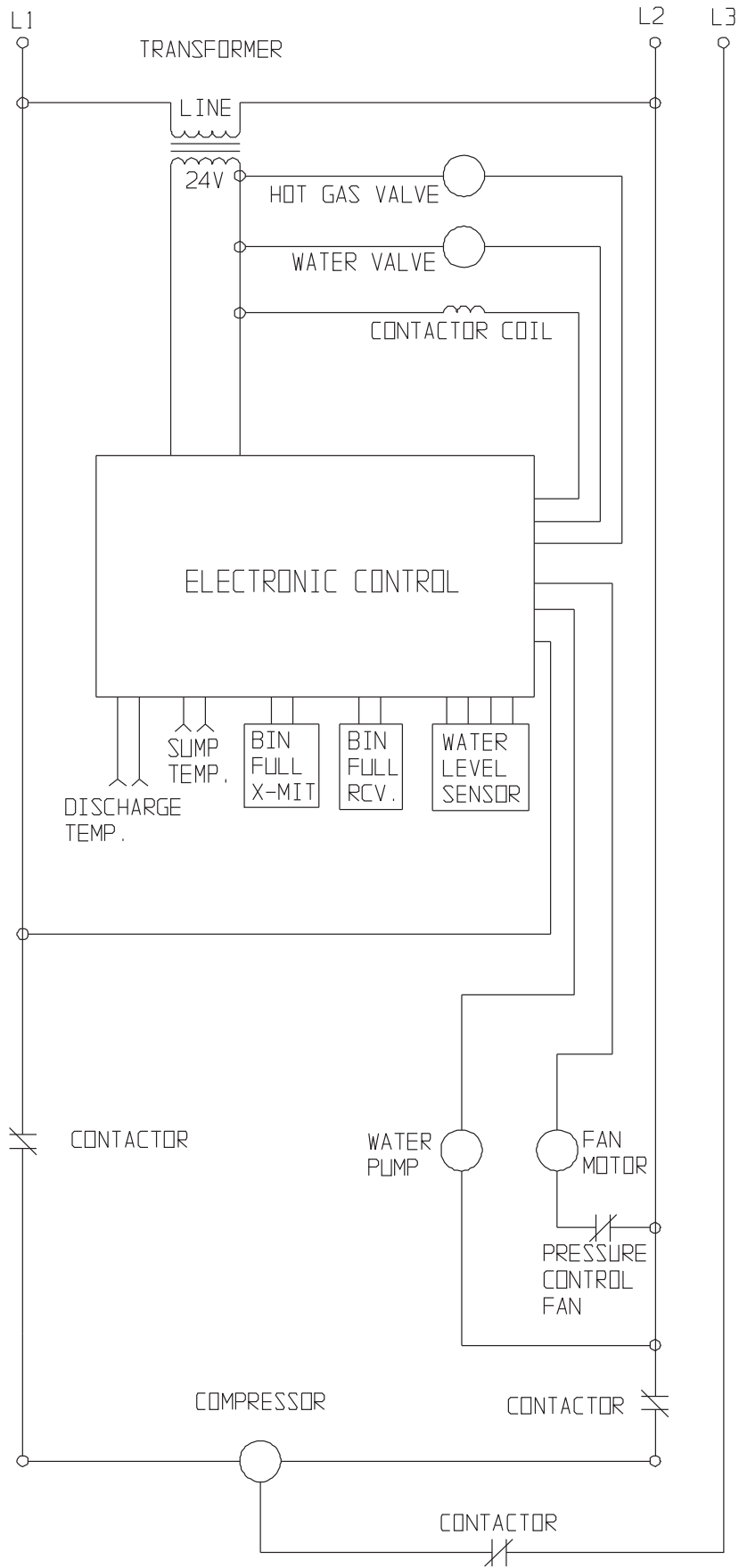

CME256 or CME506 or CME656 or CME806 Service Parts

D thru H Series CME506 50 Hz Air Cooled Diagram

17-2749-01

USE COPPER CONDUCTORS ONLY

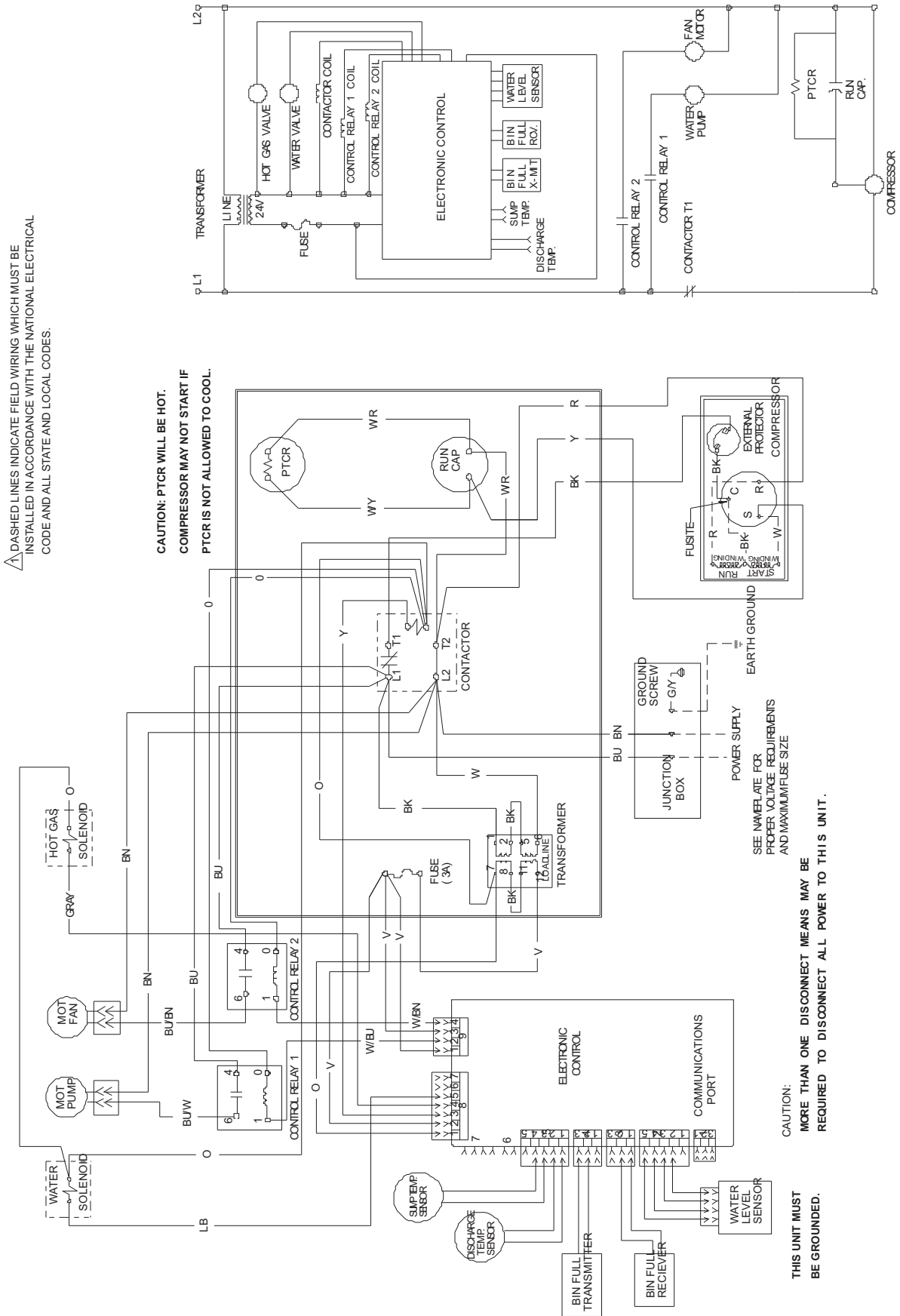

▲ DASHED LINES INDICATE FIELD WIRING WHICH MUST BE INSTALLED IN ACCORDANCE WITH THE NATIONAL ELECTRICAL CODE AND ALL STATE AND LOCAL CODES.

CAUTION: PTCR WILL BE HOT.
COMPRESSOR MAY NOT START IF PTCR IS NOT ALLOWED TO COOL.

THIS UNIT MUST BE GROUNDED.
CAUTION: MORE THAN ONE DISCONNECT MEANS MAY BE REQUIRED TO DISCONNECT ALL POWER TO THIS UNIT.
SEE NAMEPLATE FOR PROPER VOLTAGE REQUIREMENTS AND MAXIMUM FUSE SIZE.

D thru H Series CME506 50 Hz Water Cooled Diagram

▲ DASHED LINES INDICATE FIELD WIRING WHICH MUST BE INSTALLED IN ACCORDANCE WITH THE NATIONAL ELECTRICAL CODE AND ALL STATE AND LOCAL CODES.

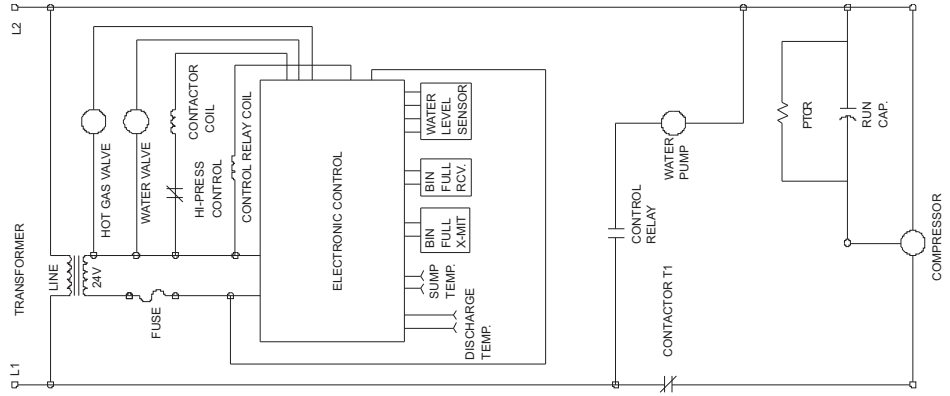

USE COPPER CONDUCTORS ONLY

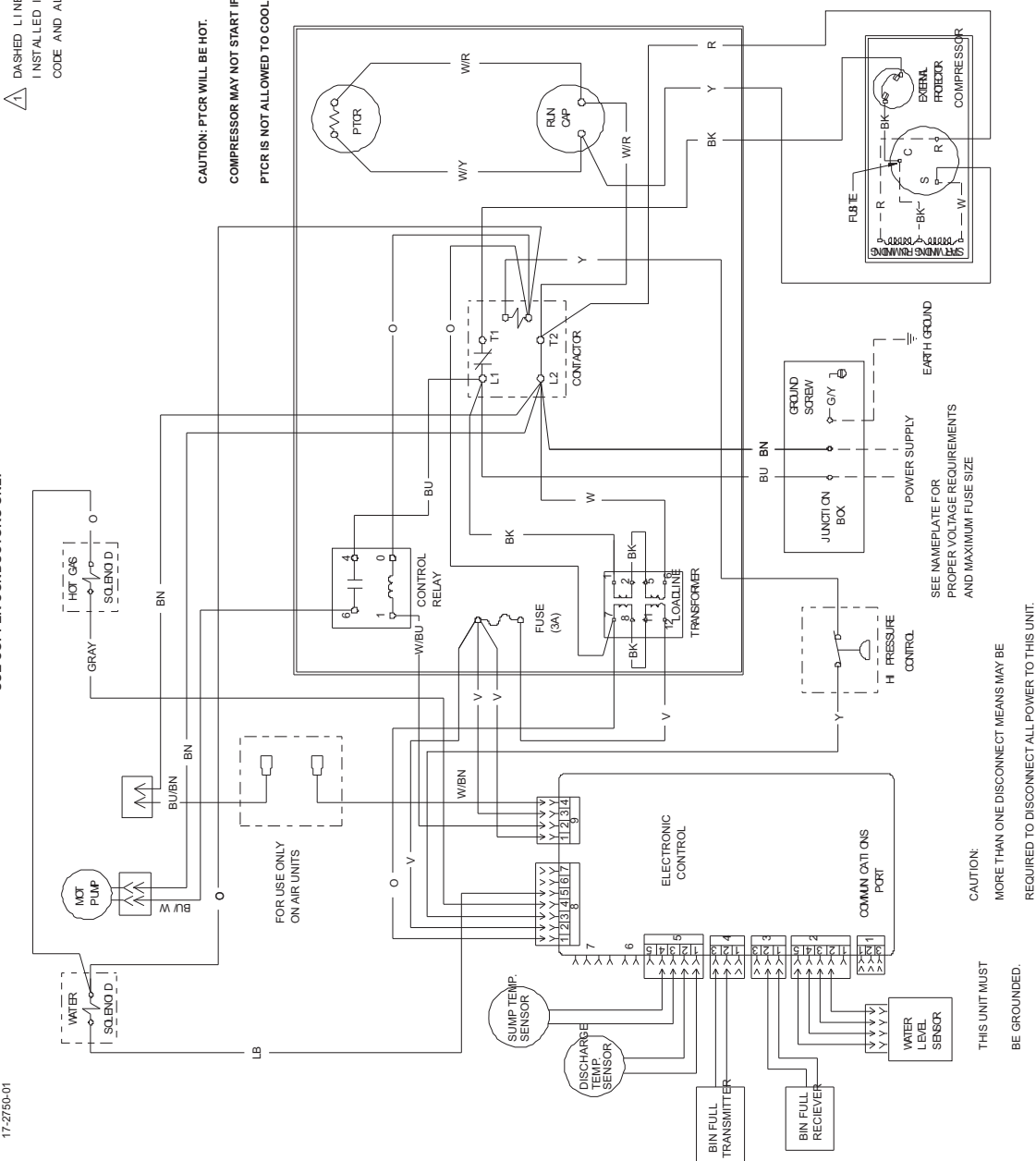

CAUTION: PTCR WILL BE HOT.
COMPRESSOR MAY NOT START IF
PTCR IS NOT ALLOWED TO COOL.

SEE NAMEPLATE FOR
PROPER VOLTAGE REQUIREMENTS
AND MAXIMUM FUSE SIZE

CAUTION:
MORE THAN ONE DISCONNECT MEANS MAY BE
REQUIRED TO DISCONNECT ALL POWER TO THIS UNIT.

THIS UNIT MUST
BE GROUNDED.

17-2750-01

CME256 or CME506 or CME656 or CME806 Service Parts

B or C Series 50 Hz Water Cooled CME506 Diagram

17-2484-01

USE COPPER CONDUCTORS ONLY

▲ DASHED LINES INDICATE FIELD WIRING WHICH MUST BE INSTALLED IN ACCORDANCE WITH THE NATIONAL ELECTRICAL CODE AND ALL STATE AND LOCAL CODES.

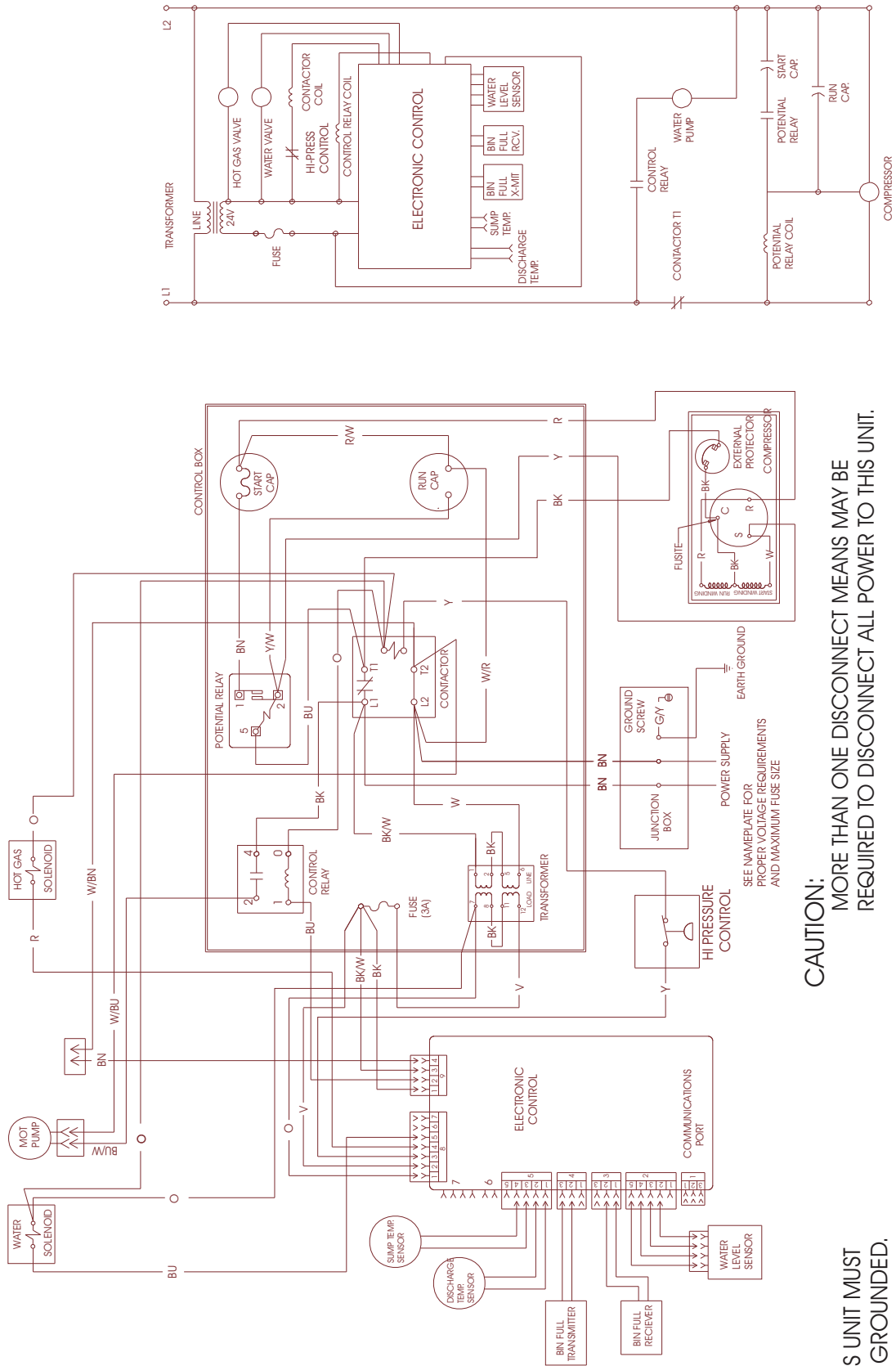

CAUTION: MORE THAN ONE DISCONNECT MEANS MAY BE REQUIRED TO DISCONNECT ALL POWER TO THIS UNIT.

THIS UNIT MUST BE GROUNDED.

B or C Series, 50 Hz Air Cooled CME506 Diagram

17-2592-01

USE COPPER CONDUCTORS ONLY

⚠ DASHED LINES INDICATE FIELD WIRING WHICH MUST BE INSTALLED IN ACCORDANCE WITH THE NATIONAL ELECTRICAL CODE AND ALL STATE AND LOCAL CODES.

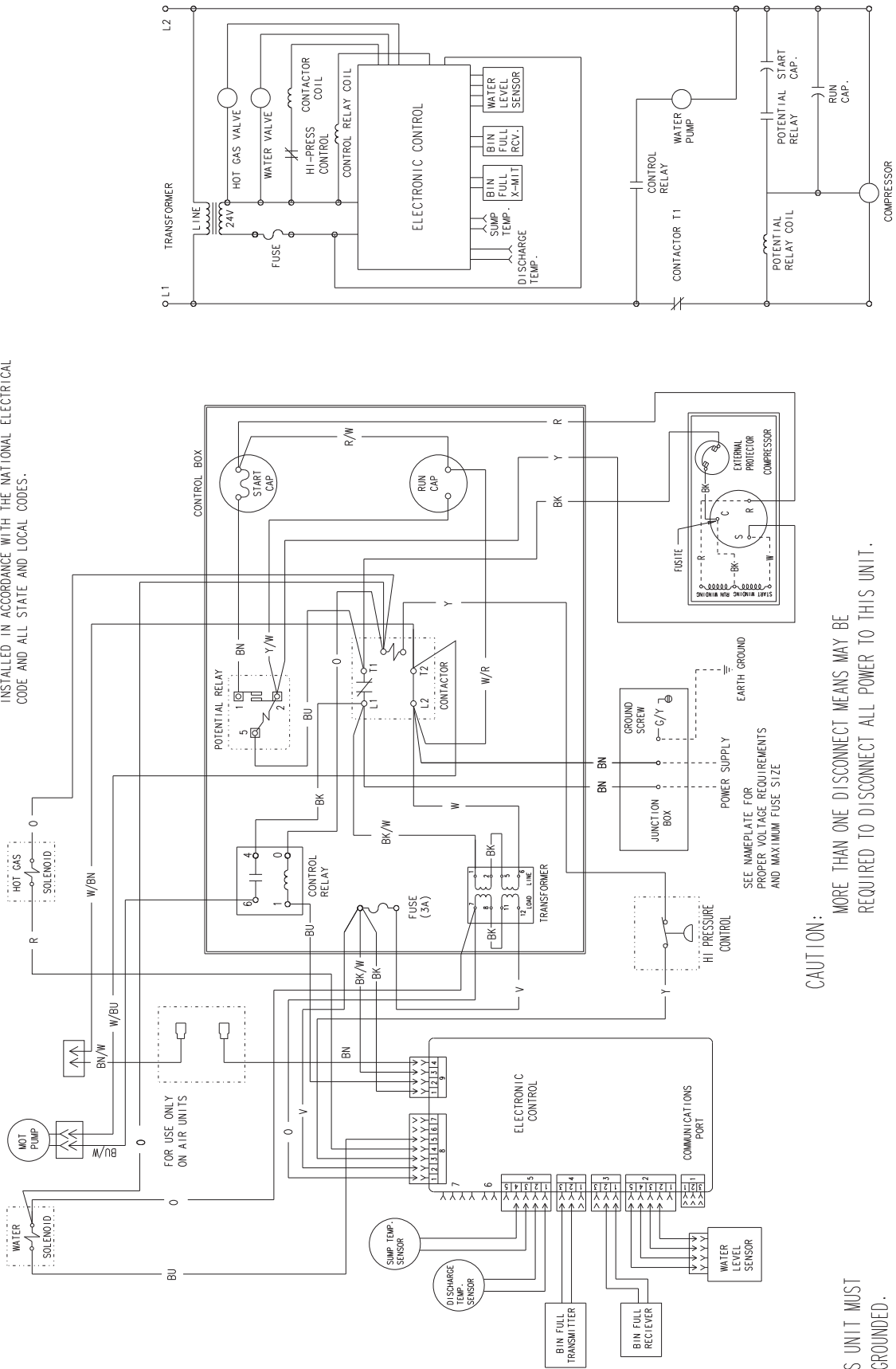

CAUTION: MORE THAN ONE DISCONNECT MEANS MAY BE REQUIRED TO DISCONNECT ALL POWER TO THIS UNIT.

THIS UNIT MUST BE GROUNDED.