

TAV. 25		Struttura GT2SFA/EA	Structure	Sturcture	Struktur	GT2SFA	GT2SFEA	DIN
	Codice	Denominazione	Denominaton	Denominaton	Bezeichnung			
1	PACU800015	Pannello comando forno gas	Panneau de contrôle four gas	Gas control panel	Steuertafel Gasofen	×		×
1	PACU800260	Pannello comando forno elettrico	Panneau de contrôle four électrique	Electric control panel	Steuertafel Elektroofen		×	×
2	PACU800014	Pannello inferiore	Panneau inférieur	Lower panel	Untere Tafel	×	×	×
3	RTBF800016	Attacco magnetico	Calamite	Magnet	Magnetanschluss	×	×	×
4	PACU800251	Maniglia fissaggio	Poignée fixe	Fix handle	Handgriff	×	×	×
5	GACU800072	Cruscotto	Panneau de contrôle	Control panel	Stirnbrett	×	×	×
6	PACU800012	Traversa portabacinella	Croisillon porte bassin	Cross bar support for collector	Wannenquerträger	×	×	×
7	PACU700207	Attacco camera combustione	Attaque chambre de combustion	Combustion chambre connection	Verbrennungskammeranschluss	×	×	×
8	PACU800008	Fianco sinistro	Côté gauche	Left side	Linke Seite	×	×	×
9	GACU800068	Camera combustion	Chambre de combustion	Combustion chambre	Brennkammer	×	×	
9	GACU800086	Camera combustion	Chambre de combustion	Combustion chambre	Brennkammer			×
10	GACU800075	Convogliatore calore	Convoyeur chaleur	Heat conveyor	Wärmeförderer	×	×	
10	GACU800085	Convogliatore calore	Convoyeur chaleur	Heat conveyor	Wärmeförderer			×
11	GACU800069	Caminetto interno	Cheminée intérieure	Internal chimney	Innenschornstein	×	×	×
12	GACU800074	Corrimano	Main courante	Handrail	Handleiste	×	×	×
13	GACU800014	Griglia camino	Grille cheminée	Chimney grill	Schornsteinrost	×	×	×
14	RTCU800002	Griglia di placca	Grille de plaque	Work plane grate	Plattenrost	×	×	×
15	GACU800013	Griglia camino	Grille cheminée	Chimney grate	Schornsteinrost	×	×	×
16	PACU800374	Schienale interno	Panneau postérieur intérieur	Internal back panel	Innenriemchen	×	×	×
17	PACU800025	Posteriore inox	Panneau postérieur inox	Inox back panel	Inox Rückwand	×	×	×
18	PACU800004	Placca	Plan de cuisson	Work plane grate	Plattenrost	×	×	×
19	PACU800240	Supporto corrimano sinistro	Support main courante gauche	Left handrail support	Handleistenhalterung	×	×	×
20	PACU800156	Protezione rubinetti	Protection robinets	Tap protection	Hahnschutz	×	×	×
21	PACU800145	Maniglia bacinella	Poignée bassin	Collector handle	Tropfenfängerhandgriff	×	×	×
22	PACU800040	Raccogliogocce	Ramasse gouttes	Drop collector	Tropfenfänger	×	×	×
23	GACU800054	Basamento	Chassis inférieure	Base	Untergestell	×	×	×
24	PACU800009	Fianco detro	Côté droite	Right side	Rechte Seite	×	×	×
25	PACU800082	Parete armadio	Paroi du placard	Cupboard door	Schrankwand	×	×	×
26	GACU800122	Piedino inox	Pied inox	Inox foot	Inox Fuss	×	×	×
27	RTTAV00006	Supporto regolatore	Support du regulateur	Regulator support	Reglerhalterung	×	×	×
28	RTCU800022	Regolatore piedino	Regulateur pied	Foot regulator	Fussregler	×	×	×
29	RTCU800029	Griglia armadio	Grille pour placard	Cupboard grate	Schrankrost	×	×	×
30	GACU800029	Facciata	Devanture	Face	Aussenvorderwand	×	×	×
31	GACU800025	Facciata forno	Devanture	Face	Ofenvorderwand	×	×	×
32	PACU800068	Contropartita armadio	Contre porte du placard	Cupboard counter door	Gegenschranktür	×	×	×
33	MPLAN40N00	Lana s/clima	Lain s/clima	S/clima wool	Isoliermaterial	×	×	×
34	RTBF800021	Gommino porta	Bouchon porte	Door rubber cap	Türgummi	×	×	×
35	PACU800122	Maniglia porta armadio	Poignée porte du placard	Cupboard door handle	Handgriff	×	×	×
36	RTCU800001	Terminale maniglia	Terminal poignée	Handle terminal	Griffanschluss	×	×	×
37	PACU800067	Porta armadio	Porte du placard	Cupboard door	Schranktür	×	×	×
38	PACU700194	Piastrina fissaggio cerniera	Egierre pour fixer la charnière	Bracket to fix hinge	Scharnierbefestigungsplättchen	×	×	×
39	GACU800037	Cerniera superiore destra	Charnière supérieur droite	Right upper hinge	Rechte Türangel	×	×	×
40	PABF900104	Cerniera inferiore porta	Charnière inférieur gauche	Left lower hinge	Untere Türangel	×	×	×
41	RTCU700051	Bussola porta	Fourreau porte	Door bush	Türbuchse	×	×	×
42	PACU800148	Piastrina unione facciate	Egierre union devantures	Bracket to join faces	Vorderwandverbindungsplatte	×	×	×
43	PACU800149	Squadretta fissaggio posteriore	Egerre fixer le panneau postérieur inox	Bracket to fix inox back panel	Rückwandbefestigungswinkel	×	×	×

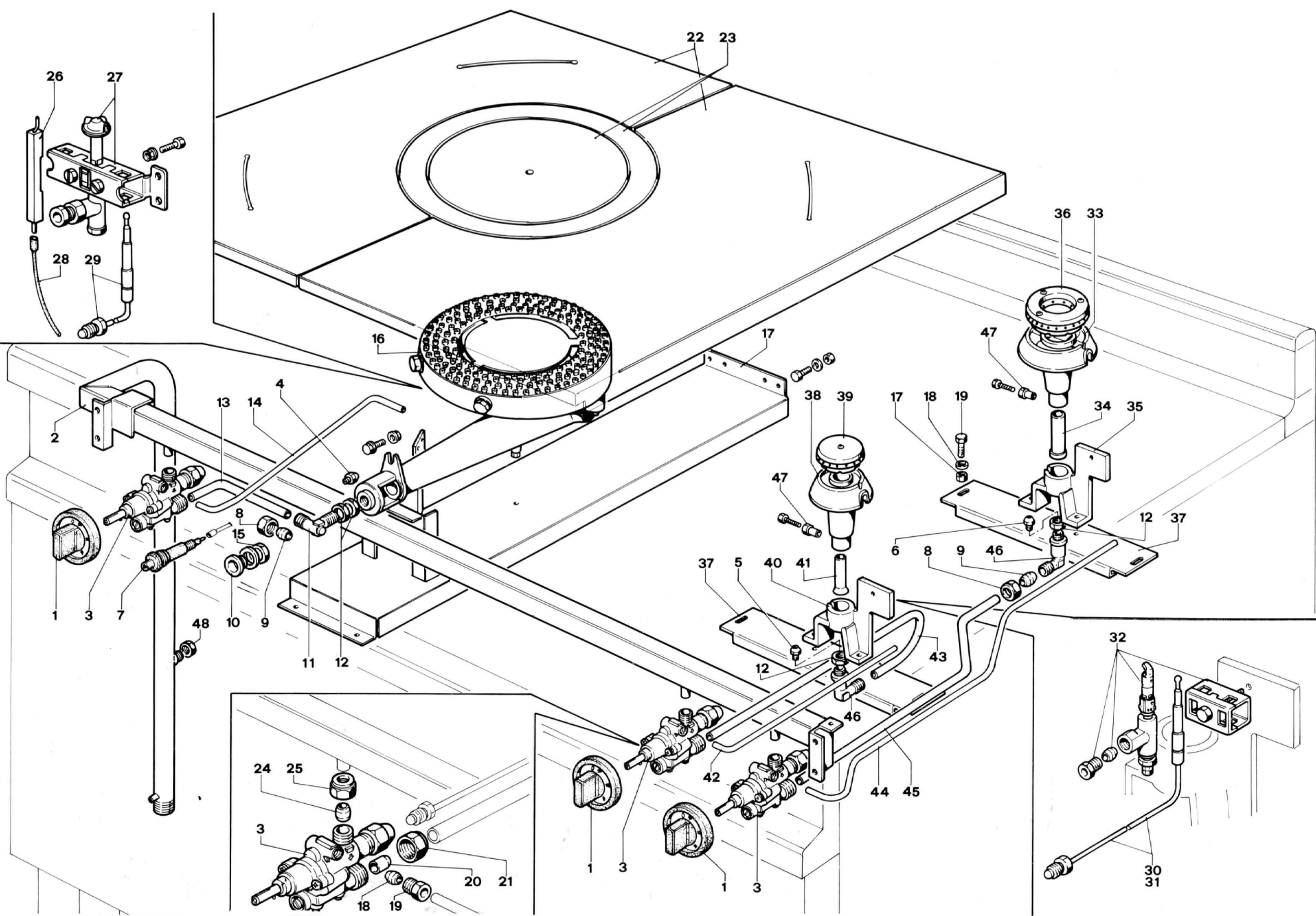

TAV. 26		Impianto gas GT2S5FA/FEA	Equipements pour gaz	Gas system equipment	Gasanlage	GT2S	GT2SFA	GT2SFEA	DIN
	Codice	Denominazione	Denominaton	Denominaton	Bezeichnung				
1	RTCU800014	Manopola rubinetto valvolato	Bouton pour soupape de sûreté	Safety valve knob	Hahnkugelgriff	x	x	x	x
2	GACU800018	Rampa	Collecteur	Collector	Speiserampe	x	x	x	x
3	RTCU900011	Rubinetto valvolato	Soupape de sûreté	Safety valve	Hahn mit Ventil	x	x	x	x
4	RTCU800098	Iniettore Ø 1,70/2,50 K per GPL	Injecteur Ø 1,70/2,50 K pour GPL	LPG injector Ø 1,70/2,50 K	Flüssiggaseinspritzer Ø 1,70/2,50 K	x	x	x	
4	RTCU800099	Iniettore Ø 2,55/3,50 L per metano	Injecteur Ø 2,55/3,50 L pour Méthane	Methane injector Ø 2,55/3,50 L	Methangaseinspritzer Ø 2,55/3,50 L	x	x	x	
4	RTCU900128	Iniettore Ø 1,60 K per GPL	Injecteur Ø 1,60 K pour GPL	LPG injector Ø 1,60 K	Flüssiggaseinspritzer Ø 1,60 K				x
4	RTCU800141	Iniettore Ø 2,70/4,10 L per metano G20	Injecteur Ø 2,70/4,10 K pour méthane G20	G20 methane injector Ø 2,70/4,10 K	G20 Methangaseinspritzer Ø 2,70/4,10 K				x
4	RTCU800142	Iniettore Ø 2,95/4,10 L per metano G25	Injecteur Ø 2,95/4,10 L pour méthane G25	G25 methane injector Ø 2,95/4,10 L	G25 Methangaseinspritzer Ø 2,95/4,10 L				x
5	RTCU700032	Iniettore Ø 0,90 K per GPL	Injecteur Ø 0,90 K pour GPL	LPG injector 0,90 K	Flüssiggaseinspritzer Ø 0,90 K	x	x	x	
5	RTCU700035	Iniettore Ø 1,35 K per metano	Injecteur Ø 1,35 K pour méthane	Methane injector Ø 1,35 K	Methangaseinspritzer Ø 1,35 K	x	x	x	x
5	RTCU900244	Iniettore Ø 0,78 K per GPL	Injecteur Ø 0,78 K pour Gpl	LPG injector Ø 0,78 K	Flüssiggaseinspritzer Ø 0,78 K				x
5	RTCU900183	Iniettore Ø 1,55 K per metano G25	Injecteur Ø 1,55 K pour méthane G25	Methane injector Ø 1,55 K	G25 Methangaseinspritzer Ø 1,55 K				x
6	RTCU900246	Iniettore Ø 1,15 K per GPL	Injecteur Ø 1,15 K pour GPL	LPG injector Ø 1,15 K	Flüssiggaseinspritzer Ø 1,15 K	x	x	x	
6	RTCU900243	Iniettore Ø 1,75 K per metano	Injecteur Ø 1,75 K pour méthane	Methane injector Ø 1,75 K	Methangaseinspritzer Ø 1,75 K	x	x	x	x
6	RTCU700220	Iniettore Ø 1,00 K per GPL	Injecteur Ø 1,00 K pour GPL	LPG injector 1,00 K	Flüssiggaseinspritzer Ø 1,00 K				x
6	RTCU700252	Iniettore Ø 1,80/2,50 L per metano G25	Injecteur Ø 1,80/2,50 L pour méthane G25	G25 methane injector Ø 1,80/2,50 L	G25 Methangaseinspritzer Ø 1,80/2,50 L				x
7	RTCU700020	Accensione piezo	Allumage piezo	Piezo lighting	Piezoelektrischer Anzünder	x	x	x	
7	RTCU700190	Accenditore piezo Cosic	Allumage piezo Cosic	Cosic piezo lighting	Piezoelektrischer Anzünder Cosic				x
8	RTCU900013	Calotta per tubo Ø 10	Écrou pour tube Ø 10	Nut for pipe Ø 10	Mutter für Schlauch Ø 10	x	x	x	
9	RTCU900012	Bicorno per tubo Ø 10	Bicorne pour tube Ø 10	Bicone for pipe Ø 10	Zweikegel Ø 10	x	x	x	
10	RTBF900020	Bussola visore	Judas	Spy hole	Monitor	x	x	x	
10	RTBF900054	Visore con vetro	Judas	Spy hole	Monitor				x
11	RTCU700001	Supporto iniettore	Support injecteur	Injector support	Einspritzhalterung	x	x	x	
11	RTCU900337	Supporto iniettore	Support injecteur	Injector support	Einspritzhalterung				x
12	RTCU900005	Contradado supporto iniettore	Contre écrou support injecteur	Lock nut for injector support	Gegenmutter	x	x	x	
13	PACU800253	Tubo alimentazione bruciatore piastra	Tube de distribution brûleur plaque	Plate burner distribution pipe	Brennerversorgungsrohr	x	x	x	
13	PACU800296	Tubo alimentazione bruciatore piastra	Tube de distribution brûleur plaque	Grate burner distribution pipe	Brennerversorgungsrohr				x
14	PACU800254	Tubo pilota bruciatore piastra	Tube veilleuse brûleur plaque	Plate burner pilot pipe	Pilotbrennerrohr	x	x	x	
14	PACU800295	Tubo pilota piastra	Tube veilleuse plaque	Grate pilot pipe	Pilotbrennerrohr				x
15	RTBF900021	Dado fissaggio visore	Écrou pour fixer la douille	Nut for fix bush	Mutter für Schlauch Ø 10	x	x	x	
16	GACU900100	Bruciatore piastra	Brûleur plaque	Plate burner	Brenner	x	x	x	
16	GACU800121	Bruciatore piastra	Brûleur plaque	Grate burner distribution pipe	Brenner				x
17	GACU800070	Traversa portabrucciato	Croisillon support brûleur	Cross bar support for burner	Brennerquerträger	x	x	x	
17	PACU800299	Traversa portabrucciato	Croisillon support brûleur	Cross bar support for burner	Brennerquerträger				x
18	RTCU900018	Bicorno per tubo Ø 6	Bicorne pour tube Ø 6	Bicone for pipe Ø 6	Zweikegel Ø 6	x	x	x	
18	RTCP800035	Bicorno per tubo Ø 4	Bicorne pour tube Ø 4	Bicone for pipe Ø 4	Zweikegel Ø 4				x
19	RTCU900019	Calotta per tubo Ø 6	Écrou pour tube Ø 6	Nut for pipe Ø 6	Mutter für Schlauch Ø 6	x	x	x	
19	RTCP800037	Calotta per tubo Ø 4	Écrou pour tube Ø 4	Nut for pipe Ø 4	Mutter für Schlauch Ø 4				x
20	RTCU900016	Bicorno per tubo Ø 10 rubinetto valvolato	Bicorne pour tube Ø 10 soupape de sûreté	Bicone for pipe Ø 10 safety tap	Zweikegel Ø 10 ( Hahn mit Ventil )	x	x	x	
21	RTCU900017	Calotta per tubo Ø 10 rubinetto valvolato	Écrou pour tube Ø 10 soupape de sûreté	Nut for pipe Ø 10 safety tap	Mutter für Schlauch Ø 10 ( Hahn mit Ventil )	x	x	x	
22	RTCU800027	Piano cottura	Plan de cuisson	Work plane	Kochfläche	x	x	x	
22	RTCU800145	Piano cottura	Plan de cuisson	Cooking plane	Kochfläche				x
23	RTCU800138	Anello piano di cottura	Anneau plan de cuisson	Work plane ring	Kochflächenring	x	x	x	
24	RTCU900014	Bicorno Ø 12 fissaggio rubinetto	Bicorne Ø 12 pour fixer le robinet	Bicone Ø 12 to fix the tap	Zweikegel Ø 12 ( für Hahn )	x	x	x	
25	RTCU900015	Calotta fissaggio rubinetto	Écrou pour fixer le robinet	Nut to fix the tap	Mutter für Hahn	x	x	x	
26	RTCU900073	Candela accensione	Bougie d'allumage	Ignition spark plug	Zündkerze	x	x	x	
26	RTCP800033	Candela accensione	Bougie d'allumage	Spark plug	Zündkerze				x
27	RTCU900074	Pilota 3 vie	Veilleuse 3 voies	3 way pilot	3 Wege Pilotbrenner	x	x	x	x

TAV. 26		Impianto gas GT2S5FA/FEA	Equipements pour gaz	Gas system equipment	Gasanlage	GT2S	GT2SFA	GT2SFEA	DIN
Codice	Denominazione	Denominaton	Denominaton	Bezeichnung					
27A	RTCP800041	Iniettore pilota Ø 0,19	Injecteur pour veilleuse Ø 0,19	Pilot injector Ø 0,19	Pilotbrennereinspritzer Ø 0,19				×
27B	RTCP800040	Iniettore pilota Ø 0,36	Injecteur pour veilleuse Ø 0,36	Pilot injector Ø 0,36	Pilotbrennereinspritzer Ø 0,36				×
28	RTBF700038	Cavo accensione	Cable d'allumage	Lighting cable	Zündkabel	×	×	×	
28	RTCU800144	Cavo accensione	Cable d'allumage	Lighting cable	Zündkabel				×
29	RTCU700148	Termocoppia cm. 50	Thermocouple cm. 50	Thermocouple cm. 50	Thermoelement cm. 50	×	×	×	×
30	RTCU900034	Termocoppia cm. 40	Thermocouple cm. 40	Thermocouple cm. 40	Thermoelement cm. 40	×	×	×	×
31	RTCU900022	Termocoppia cm. 60	Thermocouple cm. 60	Thermocouple cm. 60	Thermoelement cm. 60	×	×	×	×
32	RTCU900025	Pilota 1 via	Veilleuse 1 voie	1 way pilot	Pilotbrenner	×	×	×	×
33	RTCU700010	Brucciato tipo 5000 Kcal/h	Brûleur 5000 Kcal/h	Burner 5000 Kcal/h	Brenner 5000 Kcal/h	×	×	×	×
34	RTCU700160	Regolatore aria bruciatore 5000 Kcal/h	Disp. régl. admiss. air brûleur 5000 Kcal/h	Burner 5000 Kcal/h air shutter	Brennerluftregler 5000 Kcal/h	×	×	×	×
35	RTCU700007	Supporto bruciatore 5000 Kcal/h	Support brûleur 5000 Kcal/h	Burner support 5000 Kcal/h	Brennerhalterung 5000 Kcal/h	×	×	×	×
36	GRCU700002	Spartifiamma 5000 Kcal/h	Chapeau de brûleur 5000 Kcal/h	Burner cap 5000 Kcal/h	Flammentrenner 5000 Kcal/h	×	×	×	×
37	PACU800071	Traversa portabrucciato	Croisillon ports brûleur	Cross bar support for burner	Brenner querträger	×	×	×	×
38	RTCU700124	Brucciato tipo B	Brûleur B	B burner	Brenner B	×	×	×	×
39	RTCU700132	Spartifiamma tipo B/DIN	Chapeau de brûleur B/DIN	Burner cap B/DIN	Flammentrenner B/DIN	×	×	×	×
40	RTCU700006	Supporto bruciatore tipo 3000 Kcal/h	Support brûleur 3000 Kcal/h	Burner 3000 Kcal/h support	Brennerhalterung 5000 Kcal/h	×	×	×	×
41	PACU700029	Regolatore aria bruciatore 3000 Kcal/h	Disp. régl. admiss. air brûleur 3000 Kcal/h	Burner 3000 Kcal/h air shutter	Brennerluftregelung	×	×	×	×
42	PACU800137	Tubo pilota bruciatore anteriore	Tube veilleuse brûleur antérieur	Front burner pilot pipe	Vorderes Pilotbrennerrohr	×	×	×	×
43	RTCU800030	Tubo alimentazione bruciatore anteriore	Tube de distribution brûleur antérieur	Front burner distribution pipe	Vorderes Brennergversorgungsrohr	×	×	×	×
44	PACU800140	Tubo pilota bruciatore posteriore	Tube veilleuse brûleur postérieur	Back burner pilot pipe	Hinteres Pilotbrennerrohr	×	×	×	×
45	RTCU800031	Tubo alimentazione bruciatore posteriore	Tube de distribution brûleur postérieur	Back burner distribution pipe	Hinteres Brennergversorgungsrohr	×	×	×	×
46	RTCU900006	Supporto iniettore	Support injecteur	Injector support	Einspritzhalterung	×	×	×	×
47	RTCU700128	Contradado fissaggio regolatore aria	Contre écrou pour fix. disp. régl. adm. air	Lock nut to fix air shutter	Gegenmutter	×	×	×	×
48	RTCU900187	Tappo 3/8"	Bouchon F. 3/8"	Plug F. 3/8"	Gewindepropfen 3/8"	×	×	×	×

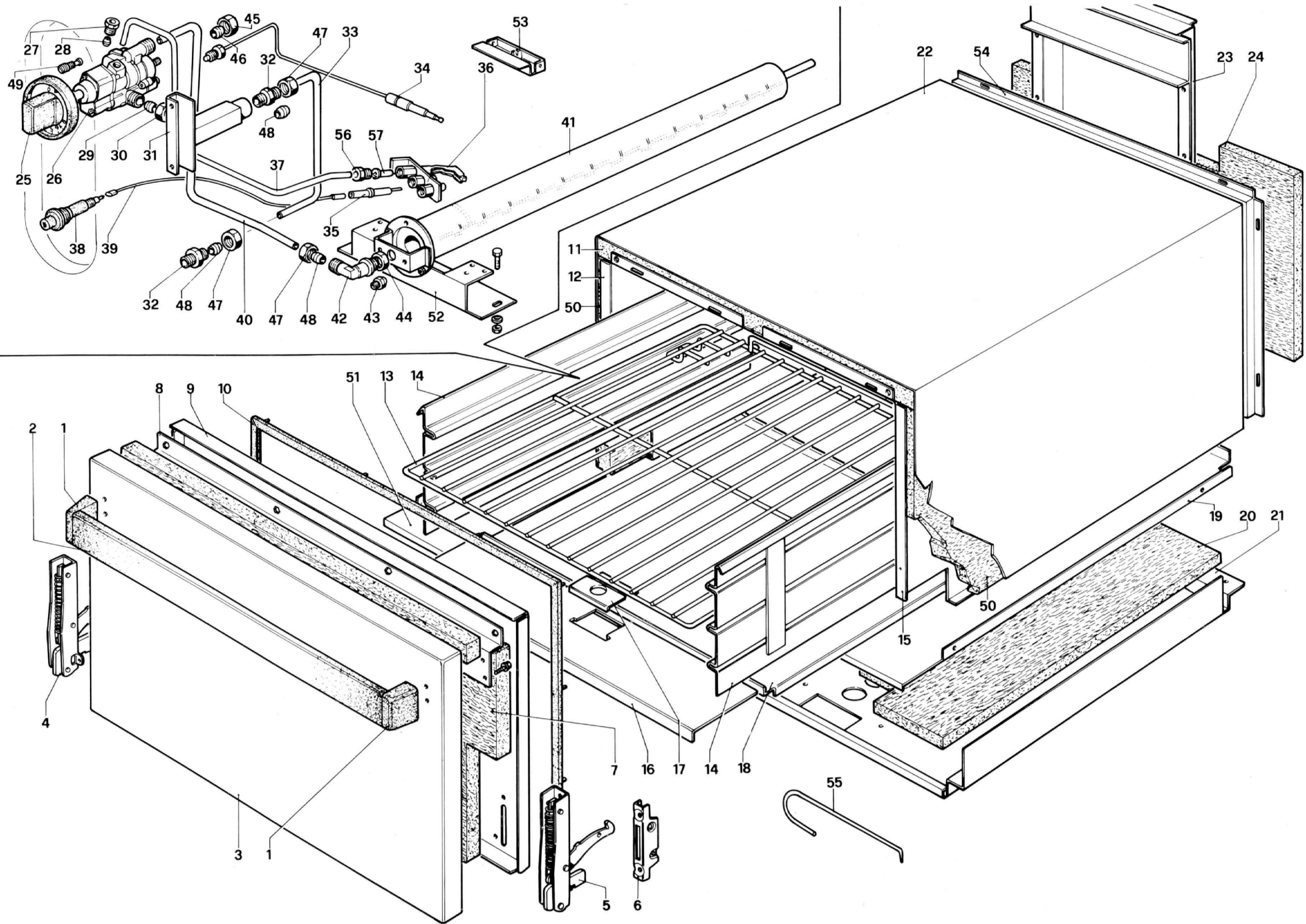

TAV. 12		Cassaforno a gas G4-6-8	Four gaz	Gas oven	Gasofen	G4SF	G6SFA	G8SF2	GTF	GT2SFA	DIN
	Codice	Denominazione	Denominaton	Denominaton	Bezeichnung						
1	RTCU800001	Terminale maniglia	Terminal poignée	Handle terminal	Griffanschluss	x	x	x	x	x	x
2	PACU800131	Maniglia porta forno	Poignée porte four	Oven door handle	Ofentürgriff	x	x	x	x	x	x
3	PACU800054	Porta forno	Porte four	Oven door	Ofentür	x	x	x	x	x	x
4	RTCU900027	Cerniera sx. ports forno	Charnière gauche porte du four	Oven door left hinge	Linke ofentürangel	x	x	x	x	x	x
5	RTCU900026	Cerniera dx. porta forno	Charnière droite porte du four	Oven door right hinge	Rechte Ofentürangel	x	x	x	x	x	x
6	RTCU900004	Porta rullino cerniera	Support charnière	Hinge support	Scharnierölträger	x	x	x	x	x	x
7	PACU800134	Pannello isolante porta	Panneau isolant porte du four	Insulating panel for door	Isoliertafel	x	x	x	x	x	x
8	PACU800038	Distanziale porta	Entretoise porte	Door spacer	Türdistanzstück	x	x	x	x	x	x
9	PACU800051	Controporta	Contre porte	Counter door	Gegentür	x	x	x	x	x	x
10	RTCU800097	Guarnizione porta	Guarniture pour porte	Cdoor gasket	Türdichtung	x	x	x	x	x	x
11	PACU800113	Pannello isolante superiore cassone	Panneau isolant superieur caisson	Body insulating upper panel	Obere Isoliertafel	x	x	x	x	x	x
12	PACU800021	Parete sx. cassone forno	Parei gauche caisson four	Oven body left wall	Linke Ofenschublade	x	x	x	x	x	x
13	RTCU800028	Griglia forno	Grille du four	Oven grate	Ofenrost	x	x	x	x	x	x
14	GACU800114	Laterale forno	Panneau latéral du four	Oven lateral panel	Seitenwand		x	x	x	x	x
15	PACU800022	Parete dx. cassone forno	Parei droite caisson four	Oven body right wall	Rechte Ofenschublade	x	x	x	x	x	x
16	PACU800096	Piano anteriore forno	Plan du four antérieur	Front oven plan	Vordere Ofenebene	x	x	x	x	x	x
17	PACU800180	Sportello accensione forno	Guichet allumage four	Oven lighting door	Tür Ofenzündung	x	x	x	x	x	x
18	GACU800129	Piano forno	Plan du four antérieur	Oven plan	Ofenebene	x	x	x	x	x	x
19	PACU800167	Doppia fondo destro	Double fond droite	Right double bottom	Doppelboden rechts	x	x	x	x	x	x
20	PACU800169	Pannello isolante fondo forno	Panneau isolant base four	Oven bottom insulating panel	Isoliertafel	x	x	x	x	x	x
21	PACU800023	Fondo cassone forno	Base caisson du four	Oven body bottom	Ofenbodenscheibe	x	x	x	x	x	x
22	PACU800115	Coprilana	Panneau couvre isolant du four	Insulating panel	Isoliermaterialverkleidung	x	x	x	x	x	x
23	GACU800027	Caminetto interno	Cheminée intérieure	Internal chimney	Innenschornstein	x	x	x	x	x	x
24	PACU800119	Pannello isolante posteriore forno	Panneau isolant postérieur du four	Oven insulating back panel	Hintere Isoliertafel	x	x	x	x	x	x
25	RTCU800019	Manopola termostato forno	Poignée thermostat du four	Oven thermostat handle	Thermostatkugelgriff	x	x	x	x	x	x
26	RTCU800011	Termostato forno	Thermostat du four	Oven thermostat	Ofen Thermostat	x	x	x	x	x	
26	RTBF800033	Termostato forno GFT	Thermostat du four GFT	Oven thermostat GFT	Ofen Thermostat GFT						x
27	RTCU900017	Calotta per tubo Ø 6	Écrou tube Ø 6	Nut for pipe Ø 6	Mutter für Schlauch Ø 6	x	x	x	x	x	x
28	RTCU900018	Bicono per tubo Ø 6	Bicone tube Ø 6	Bicone for pipe Ø 6	Zweikegel für Schlauch Ø 6	x	x	x	x	x	x
29	RTCU900014	Bicono fiss. termostato	Bicone pour fixer le thermostat	Bicone to fix the thermostat	Zweikegel für Thermostat	x	x	x	x	x	x
30	RTCU900015	Calotta fiss. termostato	Écrou pour fixer le thermostat	Nut to fix the thermostat	Mutter für Thermostat	x	x	x	x	x	x
31	GACU800002	Attacco termostato	Attaque thermostat	Thermostat connection	Thermostatanschluss	x	x	x	x	x	x
32	RTCU900132	Niples 3/8" x 1/2"	Niples 3/8" x 1/2"	Niples 3/8" x 1/2"	Nippel 3/8" x 1/2"	x	x	x	x	x	x
33	RTCU800036	Tubo alimentazione termostato G8SF2	Tube de distribution thermostat G8SF2	Thermostat distribution pipe G8SF2	Thermostatversorgungsrohr G8SF2			x			x
33	RTCU800032	Tubo alimentazione termostato G4SF	Tube de distribution thermostat G4SF	Thermostat distribution pipe G4SF	Thermostatversorgungsrohr G4SF	x	x		x	x	x
34	RTCU900060	Termocoppia cm. 75	Thermocouplecm. 75	Thermocouple cm. 75	Thermoelement cm. 75	x	x	x	x	x	x
35	RTCP800033	Candela accensione quadra	Bougie oxide carrée	Rectagular oxide spark plug	Zündkerze	x	x	x	x	x	x
36	RTCP800034	Pilota 3 vie	Veilleuse 3 voies	3 way pilot	3 Wege Pilotbrenner	x	x	x	x	x	x
37	PACU800147	Tubo pilota forno G8SF2	Tube veilleuse four G8SF2	Oven pilot G8SF2 pipe	Pilotbrennerrohr G8SF2			x			x
37	PACU800141	Tubo pilota forno G4SF	Tube veilleuse four G4SF	Oven pilot G4SF pipe	Pilotbrennerrohr G4SF	x	x		x	x	x
38	RTCU700020	Accensione piezo	Allumage piezo	Piezo lighting	Piezoelektrischer Anzünder	x	x	x	x	x	
38	RTCU700190	Accenditore piezo Cosic	Allumage piezo Cosic	Piezo lighting Cosic	Piezoelektrischer Anzünder Cosic						x
39	RTCU800144	Cavo accensione	Cable d'allumage	Lighting cable	Zündkabel	x	x	x	x	x	x
40	RTCU800037	Tubo alimentazione bruciatore forno G8SF2	Tube d'alimentation brûleur four G8SF2	Feeding pipe for oven burner G8SF2	Brennerversorgungsrohr G8SF2			x			x
40	RTCU800033	Tubo alimentazione bruciatore forno G4SF	Tube d'alimentation brûleur four G4SF	Feeding pipe for oven burner G4SF	Brennerversorgungsrohr G4SF	x	x		x	x	x
41	RTCU800039	Bruciatore forno	Brûleur four	Oven burner	Ofenbrenner	x	x	x	x	x	x
42	RTCU900337	Supporto iniettore	Support injecteur	Injector support	Einspritzhalterung	x	x	x	x	x	x
43	RTCU700034	Iniettore Ø 1,30 K per GPL	Injecteur Ø 1,30 K pour GPL	LPG injector Ø 1,30 K	Flüssiggaseinspritzer Ø 1,30 K	x	x	x	x	x	

TAV. 12		Cassaforno a gas G4-6-8	Four gaz	Gas oven	Gasofen	G4SF	G6SFA	G8SF2	GTF	GT2SFA	DIN
	Codice	Denominazione	Denominaton	Denominaton	Bezeichnung						
43	RTCU900092	Iniettore Ø 2,10 K per metano	Injecteur Ø 2,10 K pour méthane	Methane injector Ø 2,10 K	Methangaseinspritzer Ø 2,10 K	x	x	x	x	x	
43	RTCU800079	Iniettore Ø 2,10/3,50 L per GPL	Injecteur Ø 2,10/3,50 L pour GPL	LPG injector Ø 2,10/3,50 L	Flüssiggaseinspritzer Ø 2,10/3,50 L						x
43	RTCU800101	Iniettore Ø 2,30/3,50 L per metano G20	Injecteur Ø 2,30/3,50 L pour méthane G20	G20 methane injector Ø 2,30/3,50 L	G20 Methangaseinspritzer Ø 2,30/3,50 L						x
43	RTCU800102	Iniettore Ø 1,25/2,50 L per metano G25	Injecteur Ø 1,25/2,50 L pour méthane G25	G25 methane injector Ø 1,25/2,50 L	G25 Methangaseinspritzer Ø 1,25/2,50 L						x
44	RTCU900005	Contradado	Contre écrou	Lock nut	Gegenmutter	x	x	x	x	x	x
45	RTCU900017	Calotta per tubo Ø 10 rubinetto valvolato	Écrou tube Ø 10 soupape de sûreté	Nut for pipe Ø 10 safety valve	Mutter für Schlauch Ø 10	x	x	x	x	x	x
46	RTCU900016	Bicono per tubo Ø 10 rubinetto valvolato	Bicone tube Ø 10 soupape de sûreté	Bicone for pipe Ø 10 safety valve	Zweikegel Ø 10 ( Hahn mit Ventil )	x	x	x	x	x	x
47	RTCU900013	Calotta per tubo Ø 10	Écrou tube Ø 10	Nut for pipe Ø 10	Mutter für Schlauch Ø 10	x	x	x	x	x	x
48	RTCU900012	Bicono per tubo Ø 10	Bicone tube Ø 10	Bicone for pipe Ø 10	Zweikegel für Schlauch Ø 10	x	x	x	x	x	x
49	RTCU800071	Bypass termostato forno	Bypass thermostat four	Bypass thermostat oven	Bypassventil Ofenthermostat	x	x	x	x	x	
49	RTCU800046	Bypass termostato forno Ø 55	Bypass thermostat four	Bypass thermostat oven	Bypassventil Ofenthermostat						x
50	PACU800172	Pannello isolante laterale forno	Panneau isolant latéral four	Insulating lateral oven panel	Isoliertafel	x	x	x	x	x	x
51	PACU800168	Doppia fondo sinistro	Double fonde gauche	Left double bottom	Doppelboden links	x	x	x	x	x	x
52	PACU800135	Squadretta fiss. bruciatore forno	Equerre pour fixer brûleur du four	Bracket to fix oven burner	Brennerbefestigungswinkel	x	x	x	x	x	x
53	PACU700143	Porta bulbo termostato	Porte boule de thermostat	Thermostat bulb support	Thermostatkugelträger	x	x	x	x	x	x
54	GACU800057	Poateriore cassone forno	Postérieur caisson du four	Back oven Body	Ofenschubladenrückwand	x	x	x	x	x	x
55	RTCU900030	Ferro di manovra	Crochet de déplacement	Removal hook	Bedienungseisen	x	x	x	x	x	x
56	RTCP800038	Raccordo per pilota	Écrou pour veilleuse	Nut for pilot	Mutter für Pilotbrenner	x	x	x	x	x	x
57	RTCP800041	Iniettore pilota Ø 0,19 per GPL	Injecteur Ø 0,19 pour GPL	LPG injector Ø 0,19	Flüssiggaseinspritzer Ø 0,19	x	x	x	x	x	x
57	RTCP800040	Iniettore pilota Ø 0,36 per metano	Injecteur Ø 0,36 pour méthane	Methane injector Ø 0,36	Methangaseinspritzer Ø 0,36	x	x	x	x	x	x