

CME865R & CME1002R SERVICE PARTS

This parts list contains the parts for the CME865R and the CME1002R. The model number of the machine is located on the ice machine in two places: on the back panel, and behind the front panel below the control box.

Check the model number to be certain of obtaining the correct parts.

Note: Some of these two models may have been manufactured in 50 Hz. They are designated with a "-6" at the end of the model number, such as CME1002RE-6A.

Always check the model number or voltage on the nameplate when ordering compressors or control box components.

TABLE OF CONTENTS

Cabinet	Page 2
Interior Cabinet	Page 3
Refrigeration System	Page 4
Water System	Page 5
Control Box	Page 6
Remote Condenser	Page 7
Ice Storage Bin	Page 8
Wiring Diagrams	Page 9

CME865R & CME1002R SERVICE PARTS CABINET

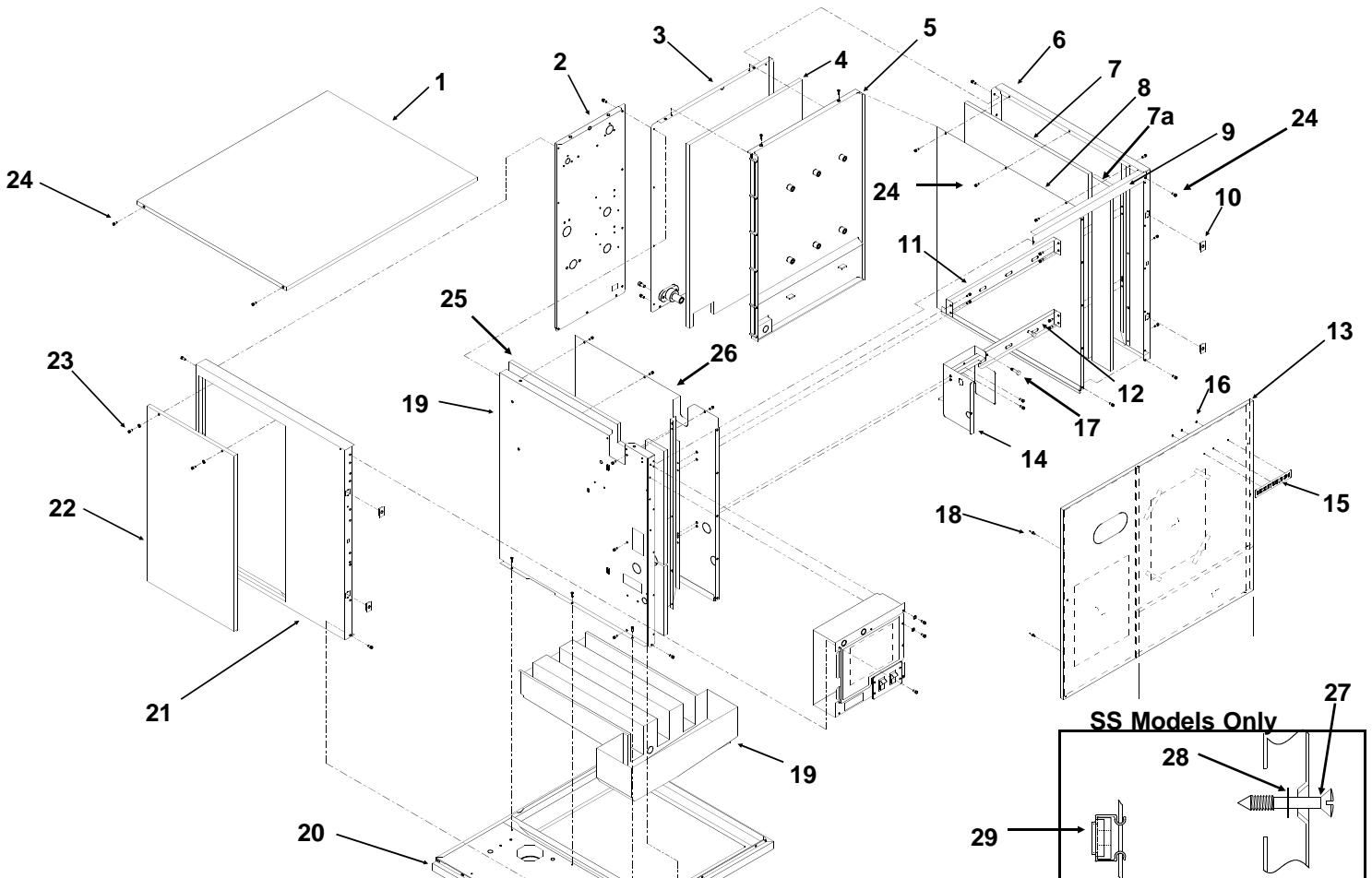

ITEM NUMBER	PART NUMBER	DESCRIPTION	ITEM NUMBER	PART NUMBER	DESCRIPTION
1	A32159-002	Top Panel, SS	13	A36468-001	Front panel, sandalwood
	A32159-001	Top Panel, sandalwood		A36468-015	Front panel, gray
	A32159-015	Top panel, gray		A36468-002	Front panel, SS
2	A36317-003	Small back panel, s-wood	14	A36308-001	Pump housing
	A36317-015	Small back panel, gray	15	15-0711-01	Emblem for sandalwood
	A36317-003	Small back panel, SS		15-0808-03	Emblem, for SS or gray
3	A32452-001	Right back panel, s-wood	16	03-0271-00	Clip for emblem
	A32452-015	Right back panel, gray	17	A32464-001	Stand off for curtain
	A32452-002	Right back panel, SS	18	15-0411-00	Strike
4	A32458-002	Back insulation	19	A35861-001	Reservoir Assembly
5	02-2888-01	Back Liner	20	A34861-002	Base Assembly
6	A35453-001	Right side panel, sandalwood	21	A32435-002	Left Side Panel, SS
	A35453-015	Right side panel, gray		A32435-001	Left Side Panel, s-wood
	A35453-002	Right side panel, SS		A32435-015	Left side panel, gray
7	A32458-004	Right side insulation	22	A34038-002	Service Panel, SS
7a	A32458-005	Small insulation		A34038-001	Service Panel, s-wood
8	02-2887-01	Right side liner		A34038-015	Service panel, gray
9	A32469-001	Brace	23	03-1404-12	Screw
10	02-0836-00	Catch	24	03-1531-01	Screw
11	A32587-001	Upper Evap. Brace	25	A32458-003	Insulation
12	A32467-002	Lower Evap. Brace	26	02-2885-01	Left side liner
			27	03-1702-01	Screw
			28	03-1702-02	Washer
			29	03-1703-01	Retaining nut

CME865R & CME1002R SERVICE PARTS

INTERIOR CABINET COMPONENTS

ITEM NUMBER	PART NUMBER	DESCRIPTION
1	A34908-021	Transducer
2	02-3404-01	Flange retainer
3	18-1902-55	Run capacitor, all except CME1002-6 (50 Hz)
	18-1902-57	Run capacitor for CME1002-6 (50 Hz)
4	18-1901-48	Start capacitor
	A35328-001	Capacitor cover
5	12-2446-26	Water valve
6	13-0674-02	Water inlet tube, 1.5" req.
7	A36293-001	Water inlet tube
8	16-0993-01	Receiver
9	A34825-001	Bracket
10	16-0850-01	Discharge fitting
11	11-0422-22	Head pressure control valve
12	16-0850-03	Liquid line fitting
13	11-0491-21	Liquid line valve
14	02-3319-02	Drier

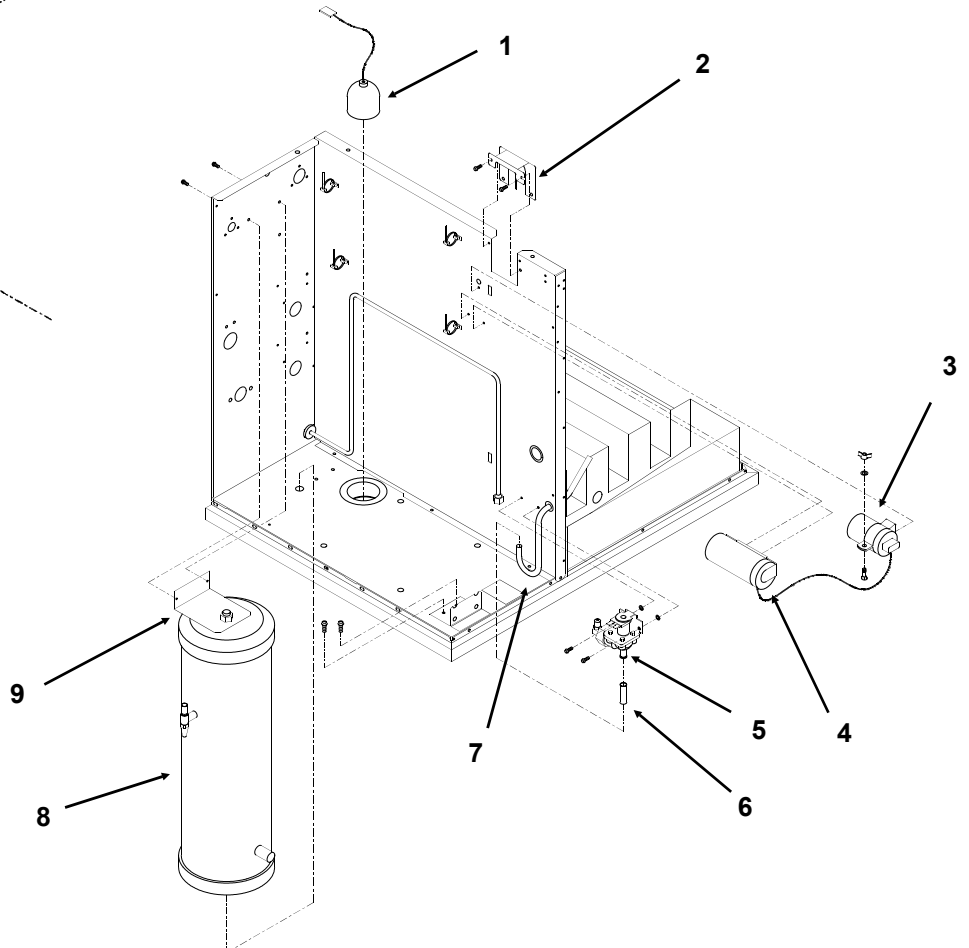
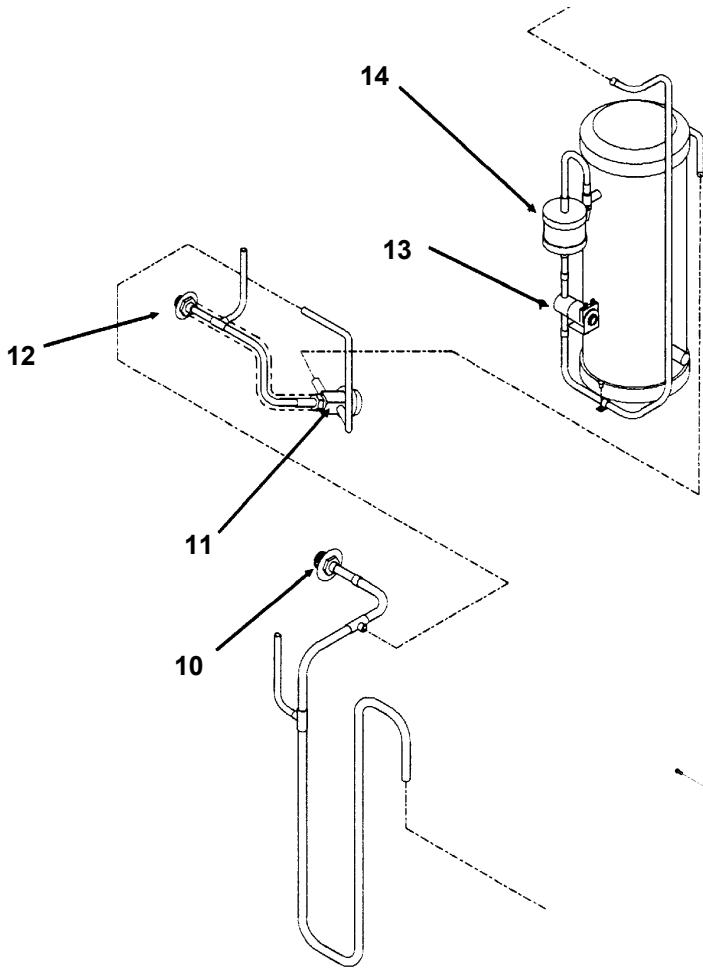

CME865R & CME1002R SERVICE PARTS

REFRIGERATION SYSTEM

ITEM NUMBER	PART NUMBER	DESCRIPTION	ITEM NUMBER	PART NUMBER	DESCRIPTION	
1	16-0876-01	Distributor and tubes	12	18-8749-22	Compressor, for CME865 60 Hz	
2	16-0875-01	Suction line header		18-8749-27	Compressor, for CME865 50 Hz	
3	16-0878-21	TXV for 60 Hz models		18-8750-22	Compressor, for CME1002 60 Hz	
	16-1022-21	TXV for 50 Hz models		18-8750-24	Compressor, for CME1002 3 Phase	
4	A30296-020	Evaporator		18-8750-27	Compressor, for CME1002 50 Hz	
5	02-3396-01	Insulation for TXV (half)				
6	16-0877-01	Hot gas manifold	Replacement compressors include a crankcase heater.			
7	11-0493-21	Hot gas valve for CME865				
	11-0491-21	Hot gas valve for CME1002		12-2308-01	Crankcase heater	
8	16-0832-20	Access valve		12-2304-01	Clip for crankcase heater	
	16-0832-03	Core or Port cap		13	11-0484-21	Pump down control switch
	16-0832-02	Stem cap		14	12-2300-07	Hi temp cut out
9	11-0501-22	Hi pressure control switch				
10	18-2200-28	Grommet				
	18-2200-27	Sleeve				
11	03-1405-20	Screw				

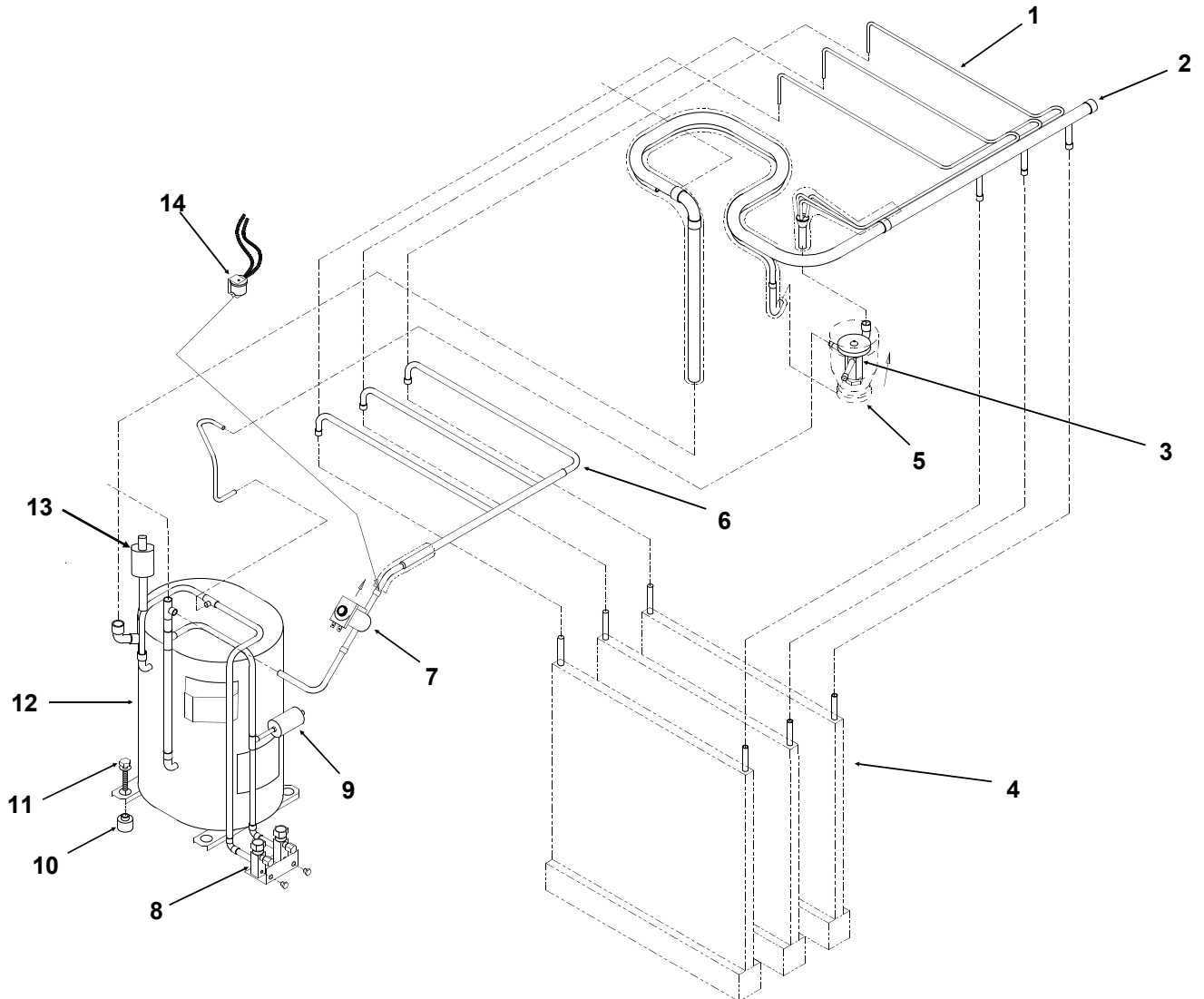

CME865R & CME1002R SERVICE PARTS

WATER SYSTEM

ITEM NUMBER	PART NUMBER	DESCRIPTION	ITEM NUMBER	PART NUMBER	DESCRIPTION
1	02-2527-01	Water Distributor Tube	15	03-1403-27	Screw
2	02-2521-01	Water Manifold, long	16	A34982-001	Drain fitting
3	13-0617-48	O-Ring	17	13-0796-01	Reservoir Drain Cap
4	A29703-001	Water Manifold, short	18	13-0617-02	O-ring
5	02-2895-01	Water Restrictor	19	13-0674-07	Drain hose (16.5" needed)
6	13-0674-07	Tube (need 30")	20	02-3094-01	Hose clamp
7	02-3094-01	Hose clamp	21	02-2606-01	Drain tube
8	02-2878-01	End cover			
9	02-2890-03	Evaporator Cover			
10	A35861-001	Reservoir, includes items 16,17,18 & 21			
11	03-1404-10	Screw			
12	13-0674-02	Hose (12" needed)			
13	12-2419-62	Water Pump			
14	A36308-001	Housing, pump			

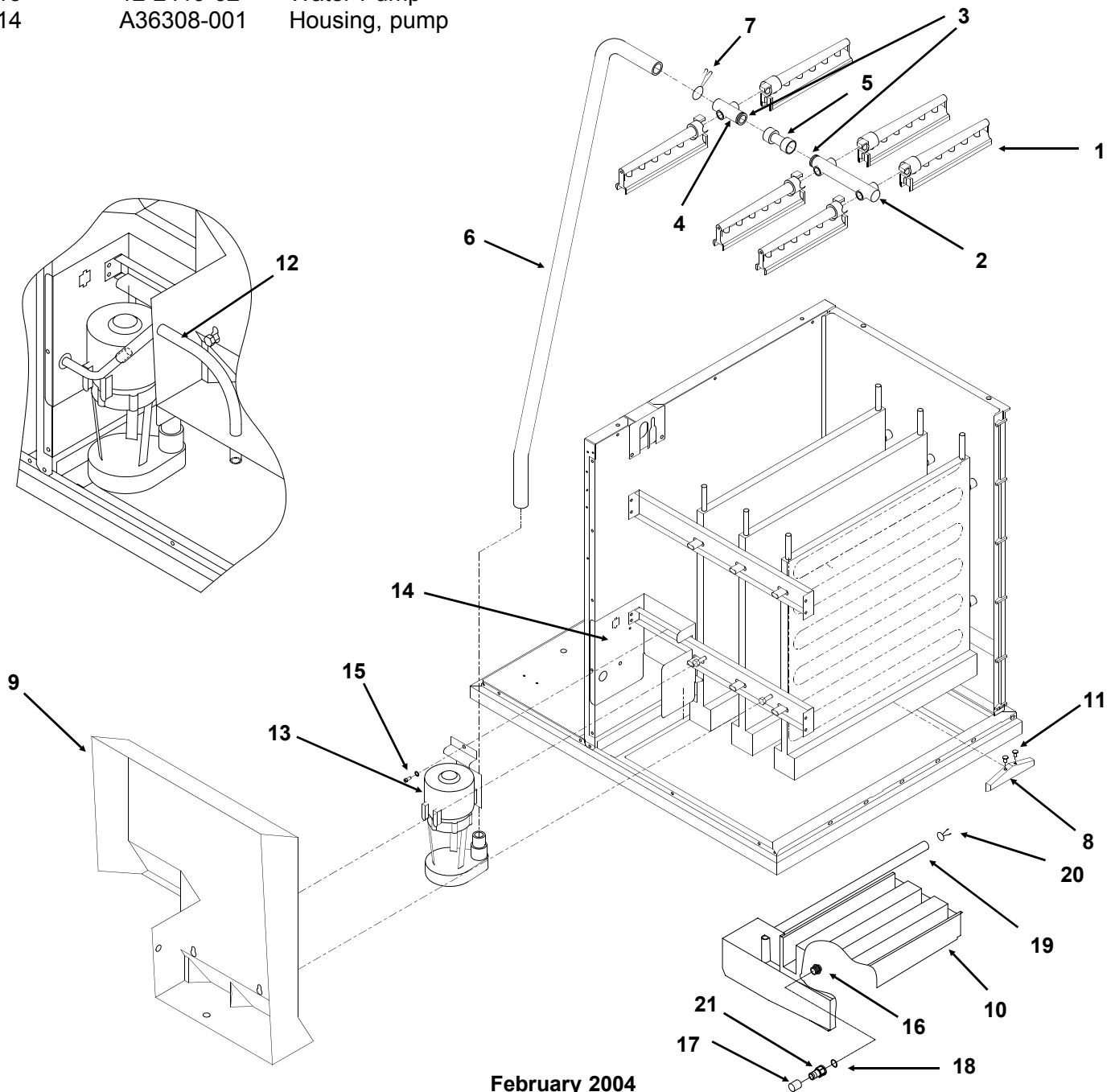

CME865R & CME1002R SERVICE PARTS CONTROL BOX

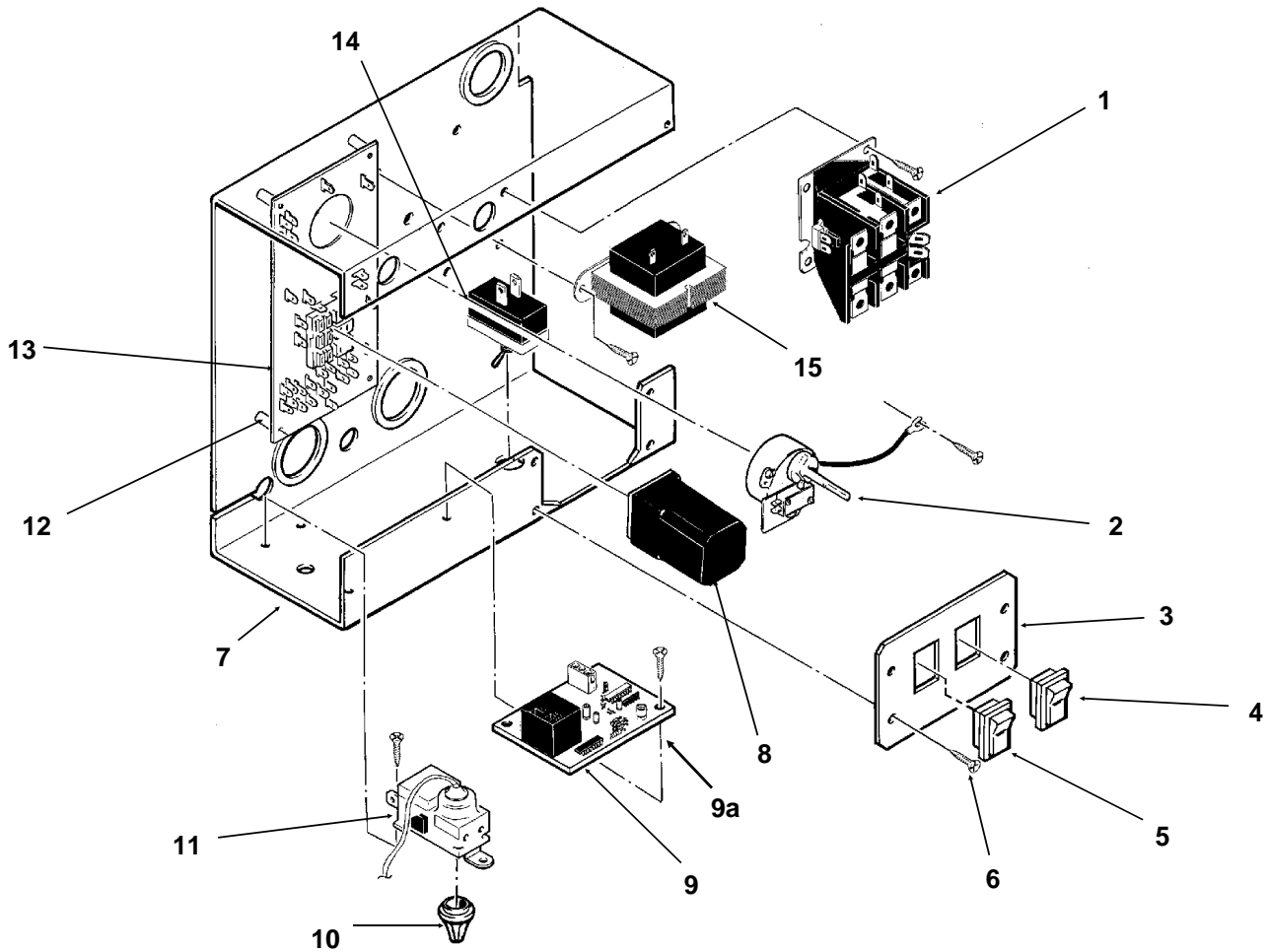

ITEM NUMBER	PART NUMBER	DESCRIPTION	ITEM NUMBER	PART NUMBER	DESCRIPTION
1	12-0739-02	Contactora 3 phase	14	12-0426-01	Compressor on off switch
	12-2469-02	Contactora single phase	15	12-2285-22	Transformer
2	12-2107-22	Timer, & switch, 60 Hz			
	12-2107-26	Timer & switch, 50 Hz			
3	02-3173-01	Cover plate	Not Shown:		
4	12-2414-01	ON/OFF/WASH switch	16	A34845-015	Control Box Cover
5	12-2411-01	Bin ice level switch	18	18-1903-46	Potential Relay for CME865 or 1002 60 Hz
	12-2402-01	Wire harness, bin level switch to sonar board		18-1903-46	Potential Relay for CME1002 50 Hz
6	03-1638-03	Screw		18-1903-33	Potential Relay for CME865 50 Hz
7	no number	Control box			
8	12-1879-03	Relay			
9	12-2376-21	Bin level control board			
9a	12-2350-01	Stand off for bin level board			
10	no number	Knob, part of item 11			
11	11-0436-21	Cube size control, includes knob			
12	02-2242-02	Stand off			
13	12-1912-01	Circuit board			

CME865R & CME1002R SERVICE PARTS

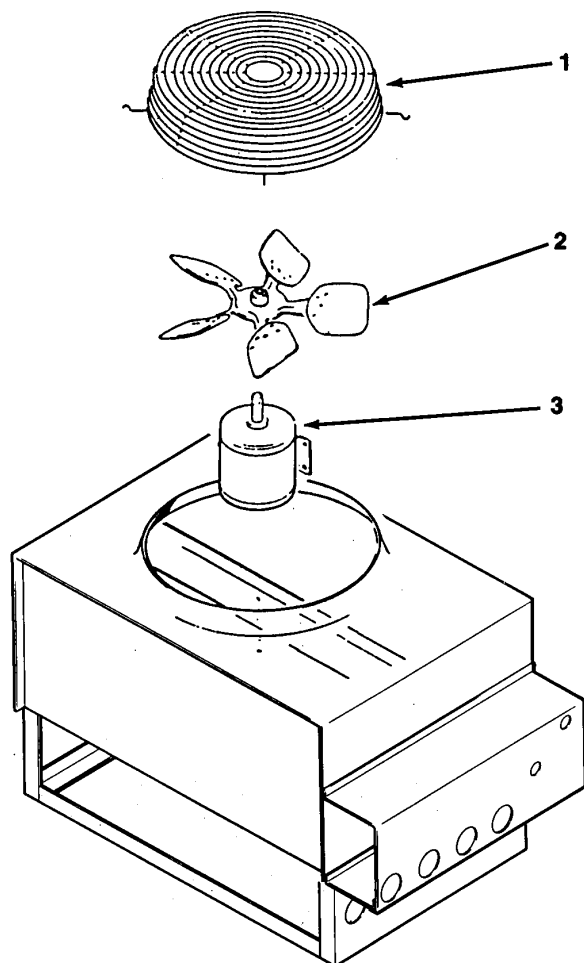

SCOTSMAN REMOTE CONDENSER

RCE1001 or RCE1002

ITEM NUMBER	PART NUMBER	DESCRIPTION
1	02-2618-01	Fan Guard
2	18-6304-01	Fan Blade
3	18-5301-01	Fan Motor
For Precharged Line set:		
4	16-1057-01	Female coupling (3/8")
5	16-1057-02	Female coupling (1/2")

ERC301

1	02-3575-01	Fan guard
2	18-8800-01	Fan blade
3	18-8797-32	Fan motor

CME865R & CME1002R SERVICE PARTS

ICE STORAGE BIN SERVICE PARTS

BH550

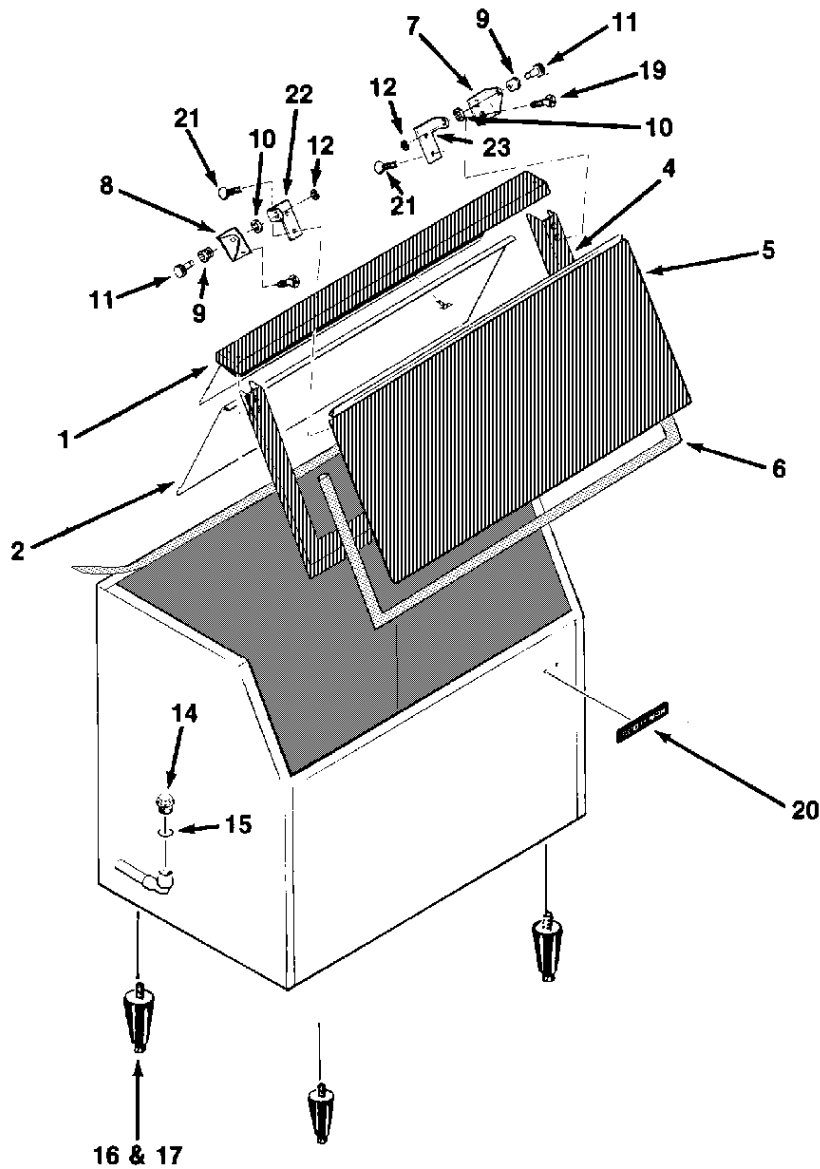

ITEM NUMBER	PART NUMBER	DESCRIPTION	ITEM NUMBER	PART NUMBER	DESCRIPTION
1	A33921-001	Canopy	14	02-2809-01	Drain Top
2	a32580-001	Baffle	15	13-0617-11	O-Ring
3	19-0503-04	Gasket	16	KLPE	Leg kit, black
4	A33922-020	Door Frame	17	KLPS	Leg kit, nickel
5	A37639-021	Door frame, C series bin	18	03-1404-06	Screw
6	A33938-020	Door	19	03-1360-02	Screw
7	13-0595-00	Door Gasket, 6' req.	20	15-0711-01	Emblem
8	A32396-002	Hinge Right	21	03-1418-41	Screw
9	A32396-001	Hinge Left	22	A32546-001	Door hinge left
10	02-2380-02	Hinge Bushing	23	A32546-002	Door hinge right
11	02-2380-02	Hinge Spacer	24	03-1423-07	Speed nut for baffle
12	02-2806-01	Shoulder Screw			
13	03-1539-09	E-Clip			
	03-0727-06	Thumb Screw			

CME865R & CME1002R SERVICE PARTS

Single Phase Wiring Diagram

Note 2:

Wire color for -32 (60 Hz) units: Black
Wire color for -6 (50 Hz) units: Brown

Power Supply: See
Nameplate for Proper
Voltage Requirements and
Maximum Fuse Size

A36451-001

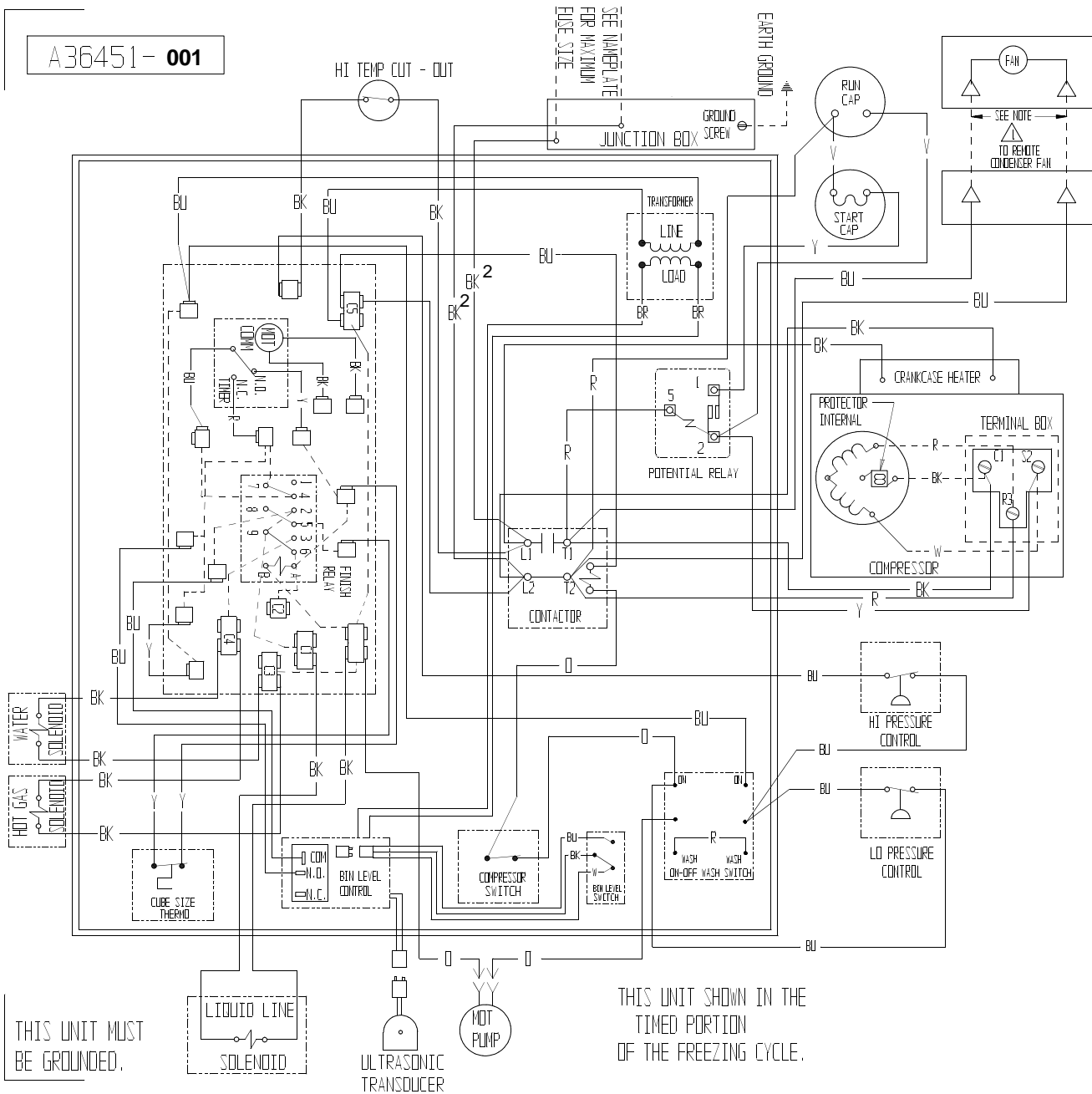

CME865R & CME1002R SERVICE PARTS

Single Phase Schematic Diagram

CAUTION:

MORE THAN ONE DISCONNECT MEANS MAY BE REQUIRED TO DISCONNECT ALL POWER TO THIS UNIT.

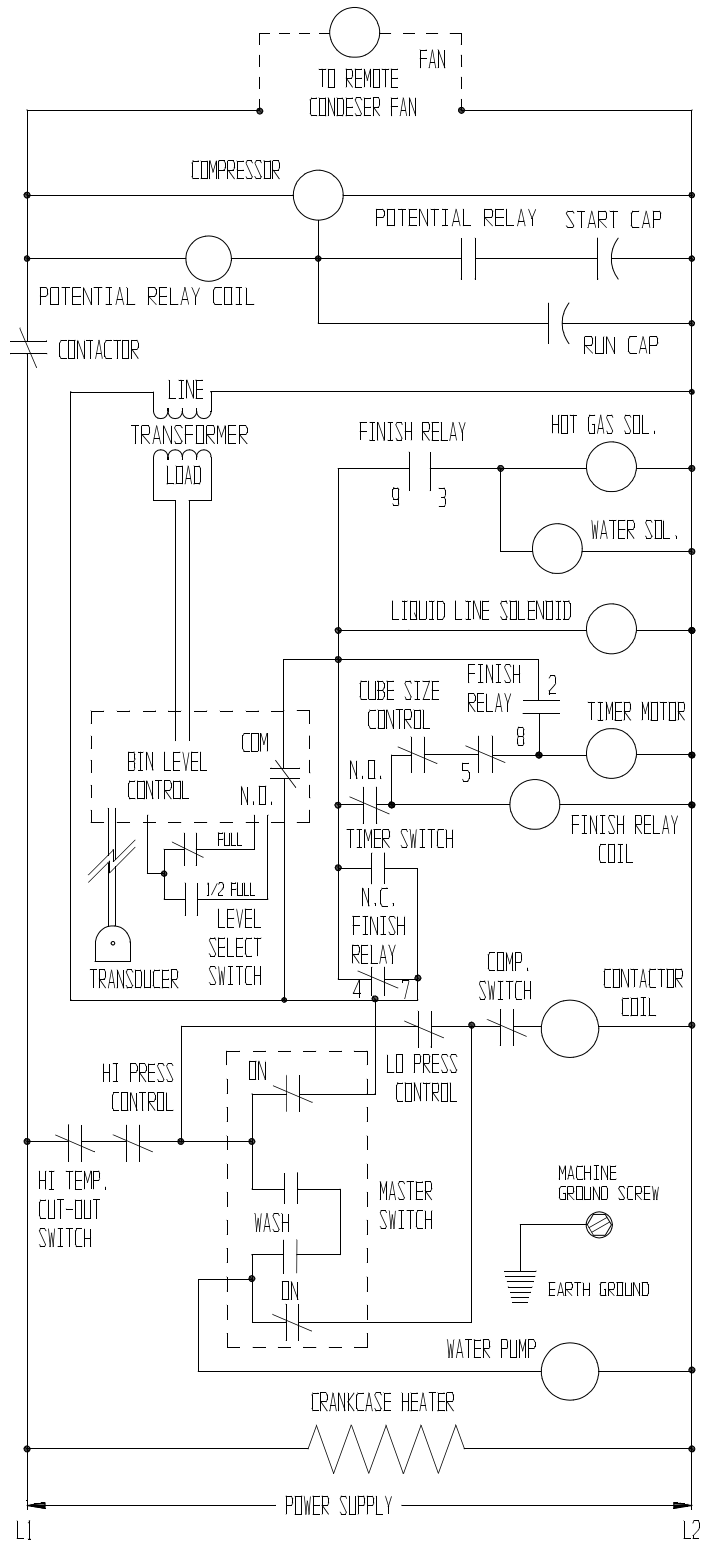

CME865R & CME1002R SERVICE PARTS

3 Phase Wiring Diagram

