



C 150

LIST OF THE EXPLODED VIEWS



SHELL ASSY

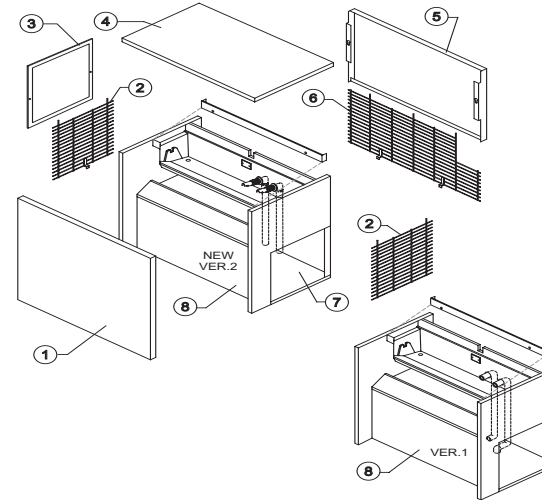

COOLING SYSTEM

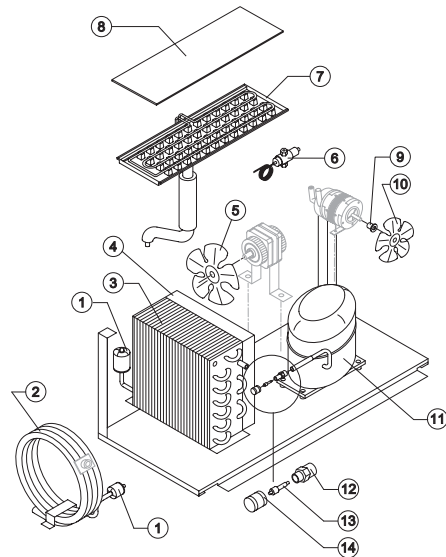

HYDRAULIC CIRCUIT

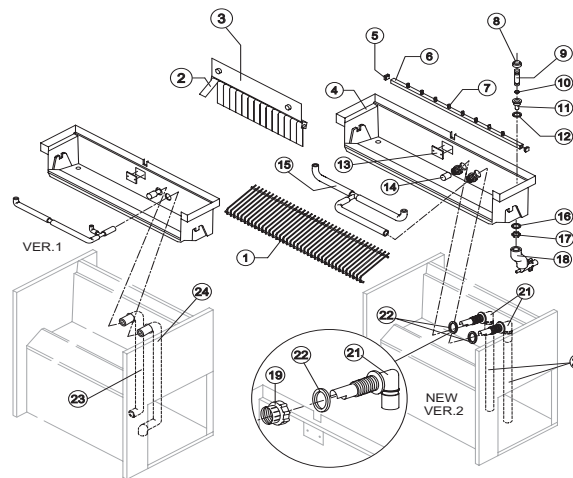

ELECTRIC PARTS

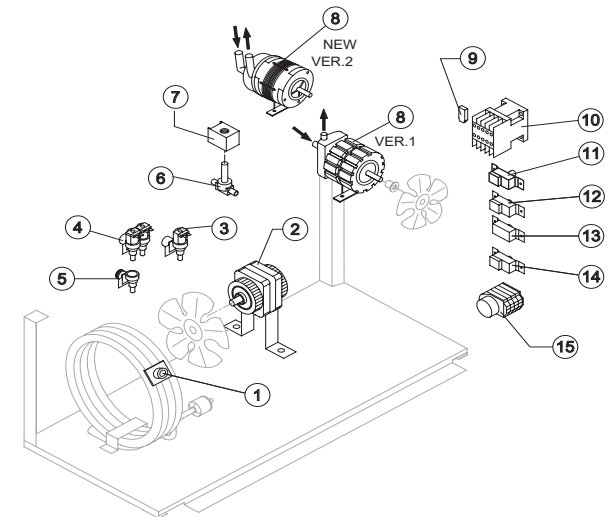

Rev. 3 - 2/7/2003



C 150

SHELL ASSY

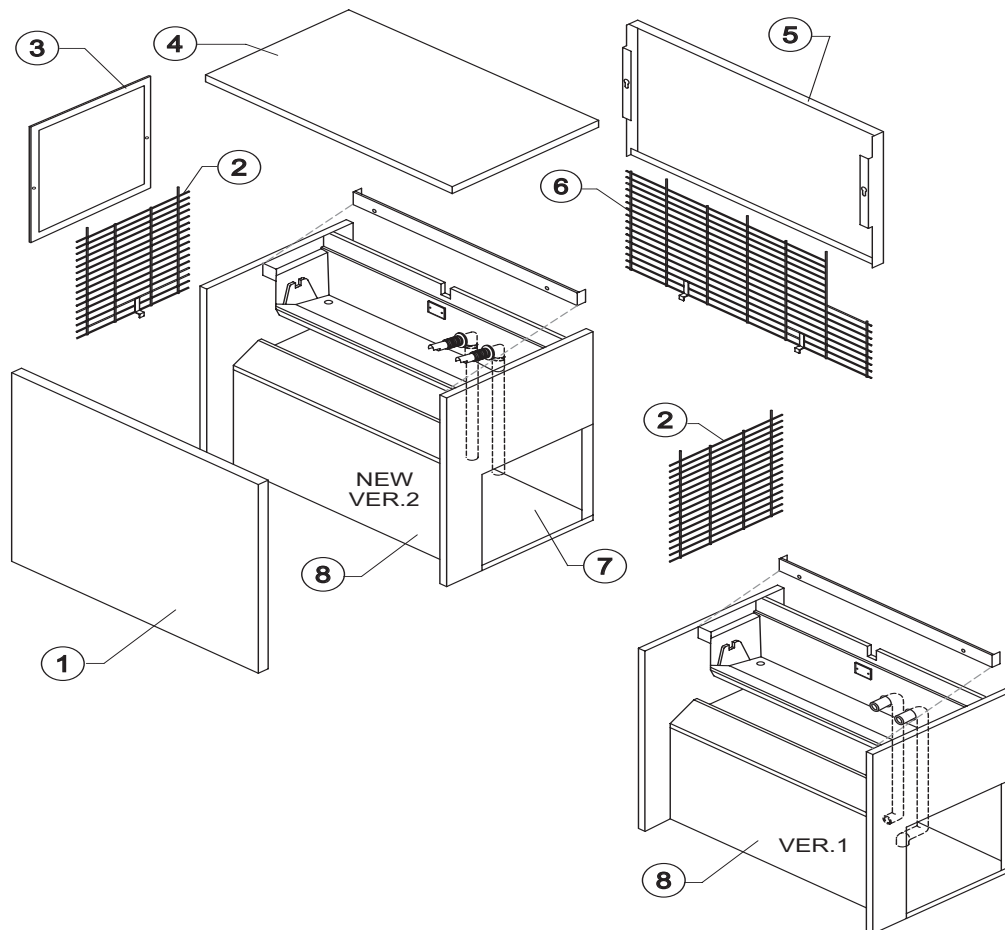

Rev. 3 - 2/7/2003

Ref.	Spare Description	Code
1	Front Panel Assembly	C22125B
2	Lateral Grid	D12036
3	Filter	Air Cooled Version 18163
4	Top Assembly	C22124
5	Back Panel	22127
6	BackGrid	Current Version D12068
6	Back Grid	Till s/n. 123682 D12035
7	Base Plate	21078
8	Foamed Cabinet Assy	See Table -

Ref. 8 - Foamed Cabinet Assy

Code	Condensation	Note
C11020A	Air	Version 2
C11020W	Water	Version 2
C11020		Version 1

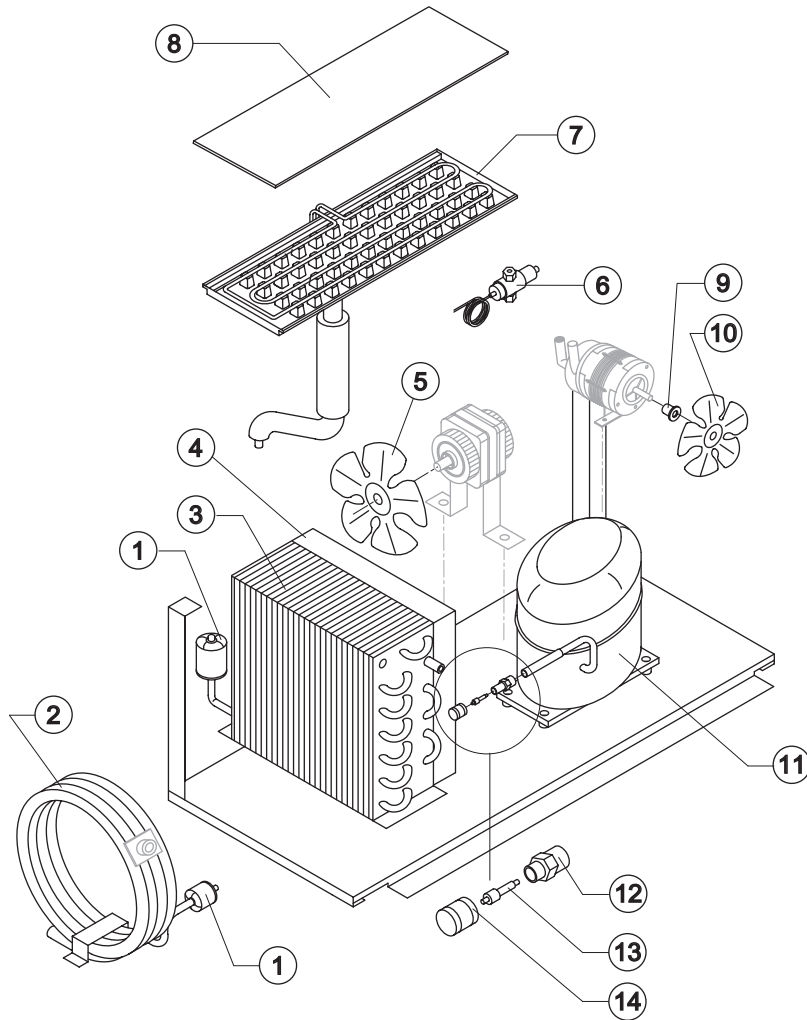

Common Parts

Ref.	Spare Description	Code
1	Solid Core Drier	14084
7	Evaporator	See Table
8	Evaporator Cover	10058
9	Hub for the Fan Fixing	10014
10	Suction Fan	10213
11	Compressor	See Table
12	Vacuum-Charge Valve Body	14007
13	Vacuum-Charge Valve Device	14005
14	Vacuum-Charge Valve Plug	14006

Parts for Air-Cooled Version Only

Ref.	Spare Description	Code
3	Air Condenser	Current Version 20426
3	Air Condenser	Till s/n. 43017 20148
4	Conveyor	Only 110V 60 Hz 10238
5	Suction Fan (Current Version)	220V 50 Hz, 230V 60 Hz 20407
5	Suction Fan (Till s/n. 43017)	220V 50 Hz, 230V 60 Hz 20153
5	Suction Fan	110V 60 Hz 20031

Parts for Water-Cooled Version Only

Ref.	Spare Description	Code
2	Water Condenser	14081
5	Suction Fan	10213
6	Pressure Valve	20210

Ref. 7 - Evaporator

Kind of Cube	Code
18 g. (Standard)	D10214
33 g. (Big)	D10092
13 g. (Small)	D10126

Ref. 11 - Compressor

Tension	Code
220/240V 50 Hz	23438
220/230V 60 Hz	23466
110/115V 60 Hz	23586



C 150

HYDRAULIC CIRCUIT

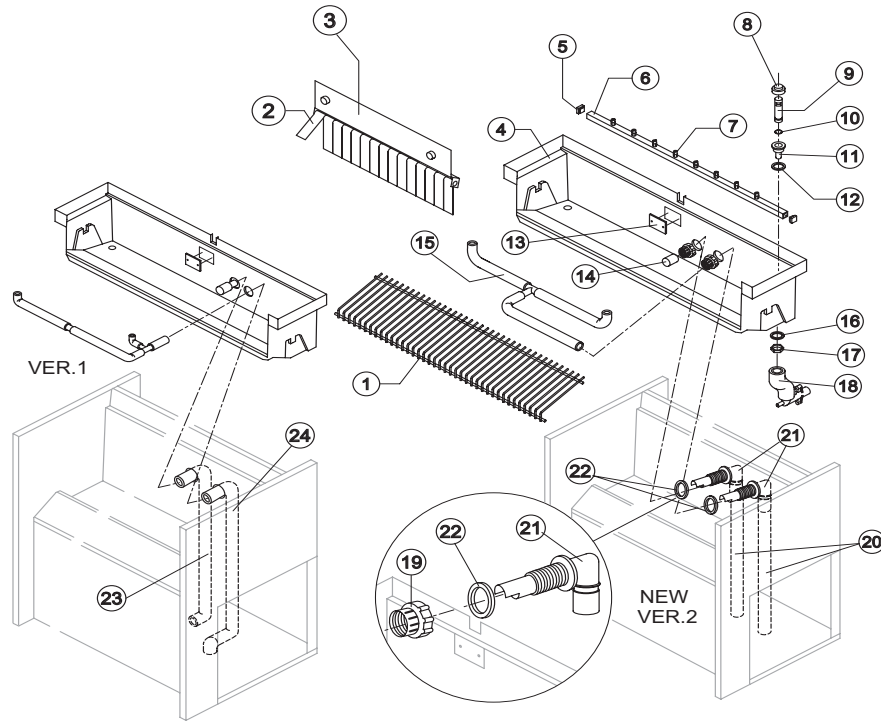

Common Parts

Ref.	Spare Description	Code
1	Ice Cubes Slide	See Table -
2	Flag	10005
3	Flags Support Assy	C22134
4	Inner Basin	10055
5	Sprayers Bar Plug	10012
6	Sprayers Bar Assembly	See Table -
7	Sprayer	D20002
8	Overflow Cap	10305
9	Overflow Pipe	10133
10	OR Gasket for Overflow Pipe	20233
11	Plastic Nipple Water Outlet	10007
12	Silicone Gasket	13006
13	Slide Keep Plate	10009
14	Pump Suction Filter	20005
15	Sprayers Feeding Pipe Connection	C13037
16	Semirigid Polyethylene Gasket	13007
17	Bin Discharge Nut	10096
19	Fitting Locking Ring	Version 2 10405
20	Pump Suction/Delivery Pipe	Version 2 13137
21	Fitting of the Pump Suction/Delivery Pipes	Version 2 10404
22	Gasket for Suction Line/Pump Delivery	Version 2 13143
23	Pump Suction Pipe	Version 1 13013
24	Pump Delivery Pipe	Version 1 13014

Ref. 1 - Ice Cubes Slide

Kind of Cube	Code
18 g. (Standard)	D12022
33 g. (Big)	D12033
13 g. (Small)	D12040

Ref. 6 -Sprayers Bar Ass.

Kind of Cube	Code
18 g. (Standard)	C20144
33 g. (Big)	C20157
13 g. (Small)	C20200

Parts for Air Cooled Version Only

Ref.	Spare Description	Code
18	Discharges Manifold	C10006

Parts for Water Cooled Version Only

Ref.	Spare Description	Code
18	Discharges Manifold	C26452

Rev. 3 - 2/7/2003



C 150

ELECTRIC PARTS

Common Parts

Ref.	Spare Description	Code
2	Fan Motor	See Table -
3	Inlet Watervlve 1 Way	See Table -
6	Hot Gas Valve Body	20409
7	Hot Gas Coil	See Table -
8	Pump	See Table -
10	Contactur	See Table -
13	Bin Thermostat	23421
14	Evaporator Thermostat	23591
15	Timer	See Table -

Parts for Air-Cooled Version Only

Ref.	Spare Description	Code
9	Anti Radio Interference Filter	Only 220V 50 Hz 23459
12	Condenser Pressure Switch	23175

Parts for Water-Cooled Version Only

Ref.	Spare Description	Code
1	Safety Thermostat	Till s/n. 105976 C23114
4	Inlet Watervlve 2 Ways (Till s/n. 123682)	See Table -
5	Inlet Water Nipple 1 Way	10368
11	Safety Pressure Switch	23342

Ref. 1 - Pump

Tension	Version 1	Version 2
220/240V 50 Hz	23068	23462
220/230V 60 Hz	23068	23462
110/115V 60 Hz	23264	23663

Ref. 2 - Fan Motor

Tension	Air	Water
220/240V 50 Hz	23121	23029
220/230V 60 Hz	23121	23029
110/115V 60 Hz	23621	23683

Rev. 3 - 2/7/2003

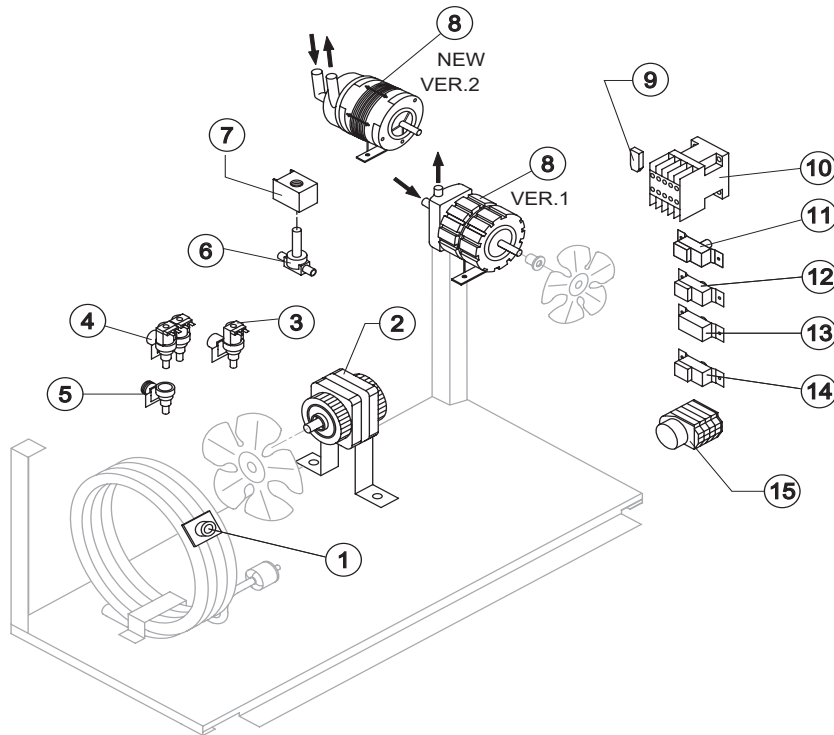

Ref. 3 - Inlet Watervlve 1 Way

Tension	Code
220/240V 50 Hz	23108
220/230V 60 Hz	23108
110/115V 60 Hz	23281

Ref. 4 - Inlet Watervlve 2 Ways

Tension	Code
220/240V 50 Hz	23138
220/230V 60 Hz	23138
110/115V 60 Hz	23282

Ref. 7 - Hot Gas Coil

Tension	Code
220/240V 50 Hz	23091
220/230V 60 Hz	23091
110/115V 60 Hz	23256

Ref. 10 - Contactur

Tension	Code
220/240V 50 Hz	23594
220/230V 60 Hz	23594
110/115V 60 Hz	23625

Ref. 15 - Timer

Tension	18g Cube	33g Cube	13g Cube
220/240V 50 Hz	23247	23248	23472
220/230V 60 Hz	23222	23396	23247
110/115V 60 Hz	23258	-	23258