

tav. C
Detail C
Detail C
Detail C

tav. A
Detail A
Detail A
Détail A

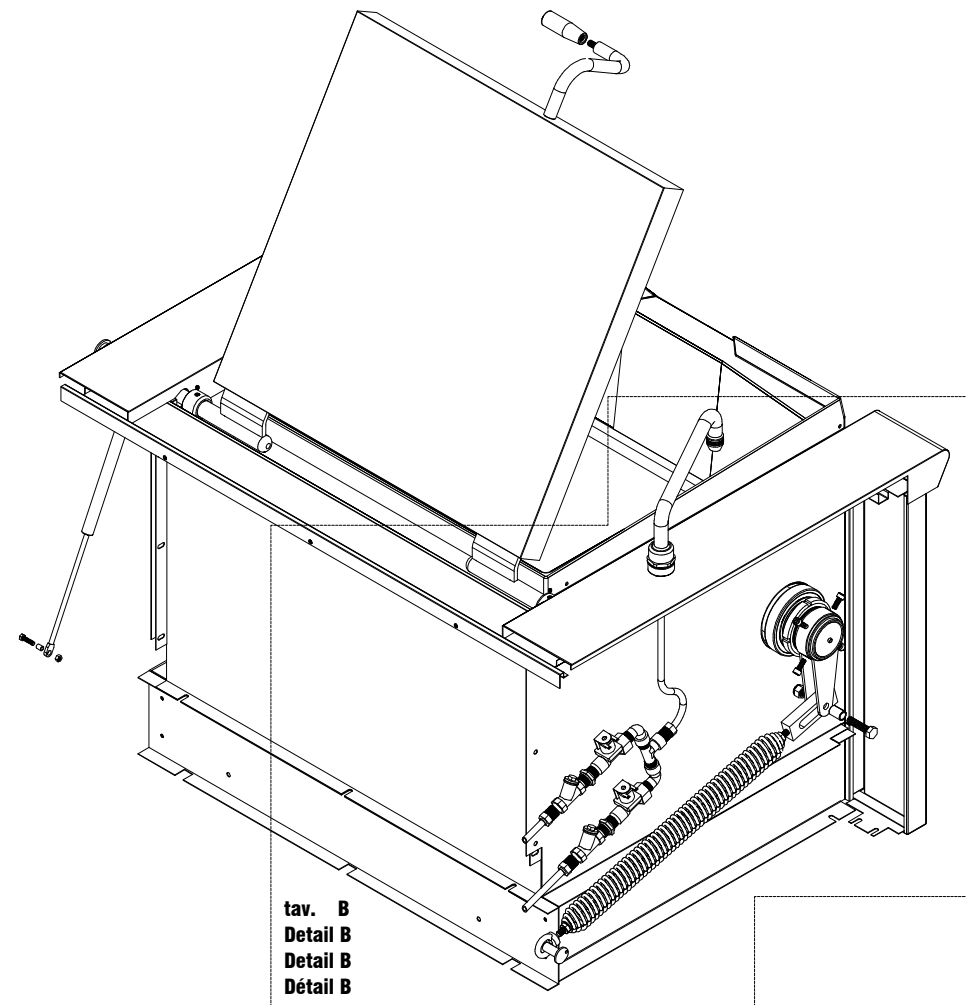

tav. B
Detail B
Detail B
Détail B

Serie Série Série Série Série	Modello Modell Model Model Model	Codice Kodex Code Code Code	Tav. Detail Detail Detail Détail
SYSTEM 900	EKB/120E II	0106913271	1/4
Primo numero di serie Erste Seriennummer First serial number Première numéro de série	Ultimo numero di serie Letzte Seriennummer Last serial number Dernière numéro de série	Revisione Revision Revision Révision	00
Disegnato Gezeichnet	Approvato Geprüft	File File	Data Datum
T. Tschigg	<i>[Signature]</i>	EKB120E-II.DWG	27/09/01
ambach GROSSKÜCHENTECHNIK - GRANDI CUCINE			39052 Kallern-Caldaro-ITALY Tel. 0471-662213 Telefax 0471-662065

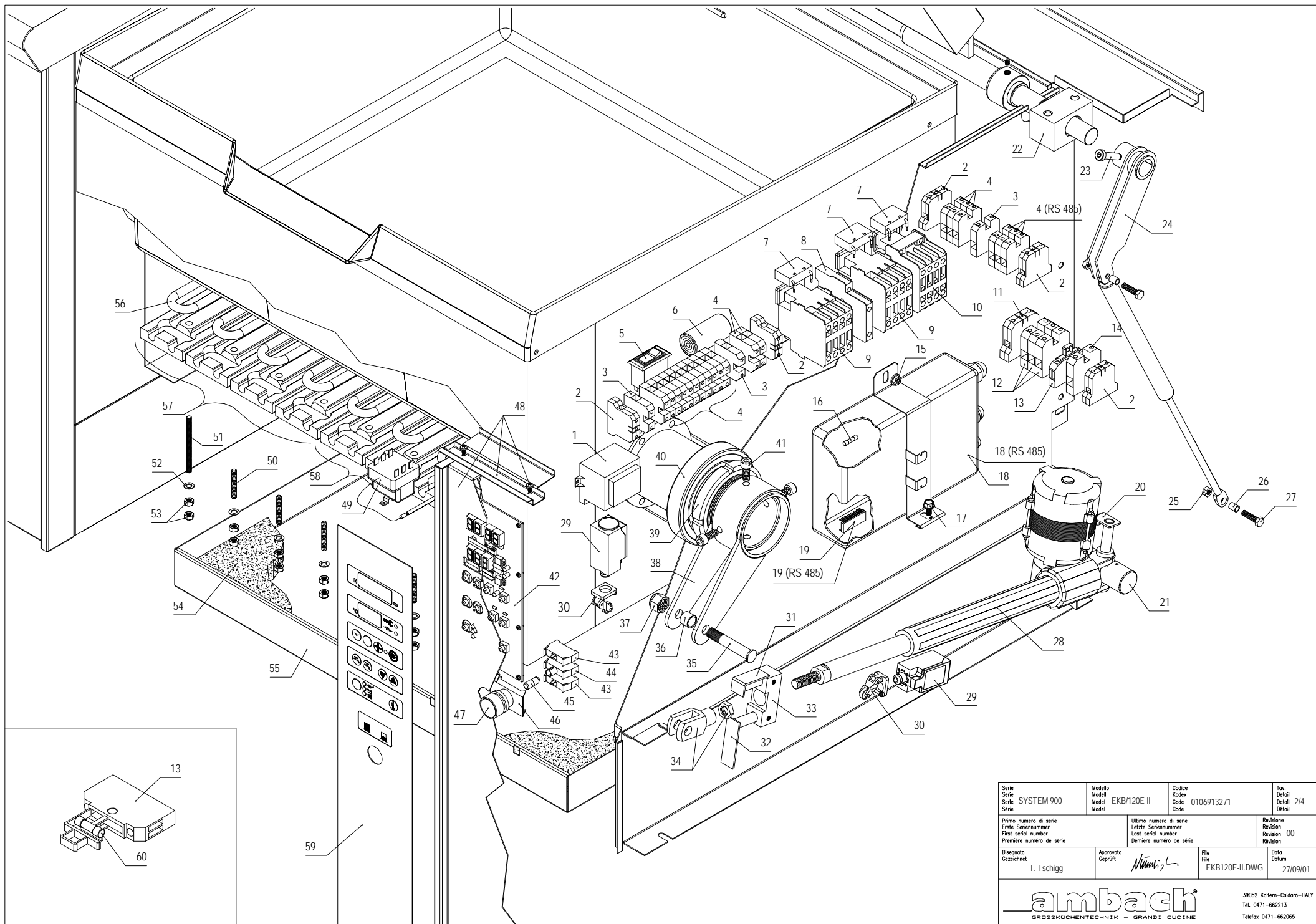

Serie Serie Série Série	Modello Model Model Model	Codice Kodex Code Code	Tav. Detail Detail Détail
SYSTEM 900	EKB/120E II	0106913271	2/4
Primo numero di serie Erste Seriennummer First serial number Première numéro de série	Ultimo numero di serie Letzte Seriennummer Last serial number Dernière numéro de série	Revisione Revision Revision Révision	00
Disegnata Gezeichnet	Approvato Geprüft	File DWG	Data Datum
T. Tschigg	<i>[Signature]</i>	EKB120E-II.DWG	27/09/01
ambach GROSSKÜCHENTECHNIK - GRANDI CUCINE			39052 Kallern-Caldaro-ITALY Tel. 0471-662213 Telefax 0471-662065

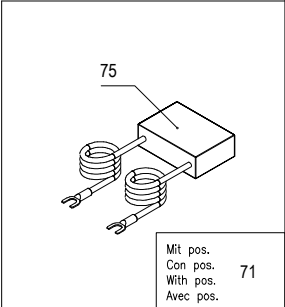
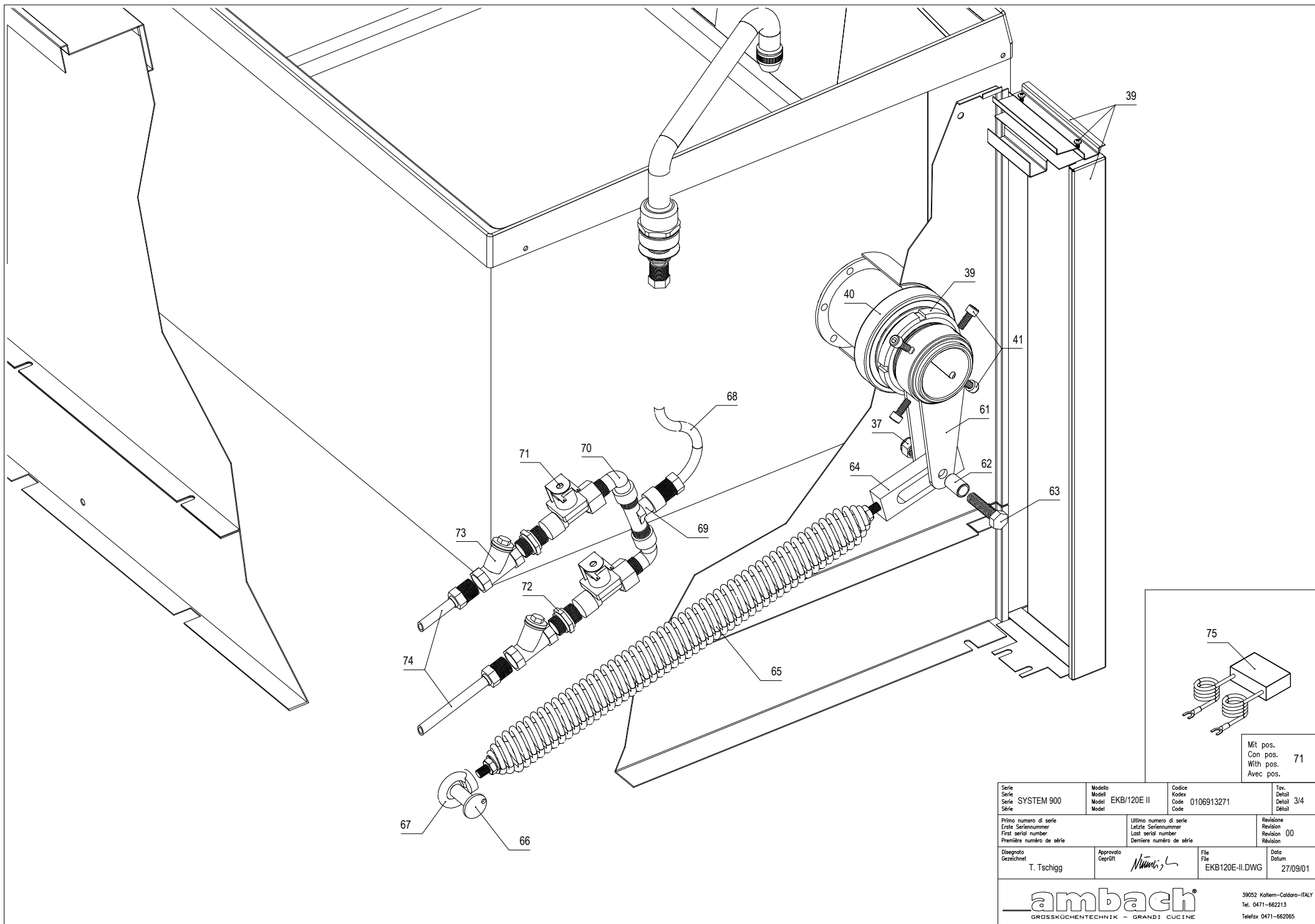

Mit pos. 71
 Con pos.
 With pos.
 Avec pos.

Serie Serie Série	Modello Modell Model	Codice Kodex Code	Tav. Detail Détail
SYSTEM 900	EKB/120E II	0106913271	3/4
Primo numero di serie Erste Seriennummer First serial number Première numéro de série	Ultimo numero di serie Letzte Seriennummer Last serial number Dernière numéro de série	Revisione Revision Revision	00
Disegnato Gezeichnet	Approvato Geprüft	File Date	Data Datum
T. Tschigg	<i>[Signature]</i>	EKB120E-II.DWG	27/09/01
ambach GROSSKÜCHENTECHNIK - GRANDI CUCINE			39052 Kattem-Caldaro-ITALY Tel. 0471-662213 Telefax 0471-662065

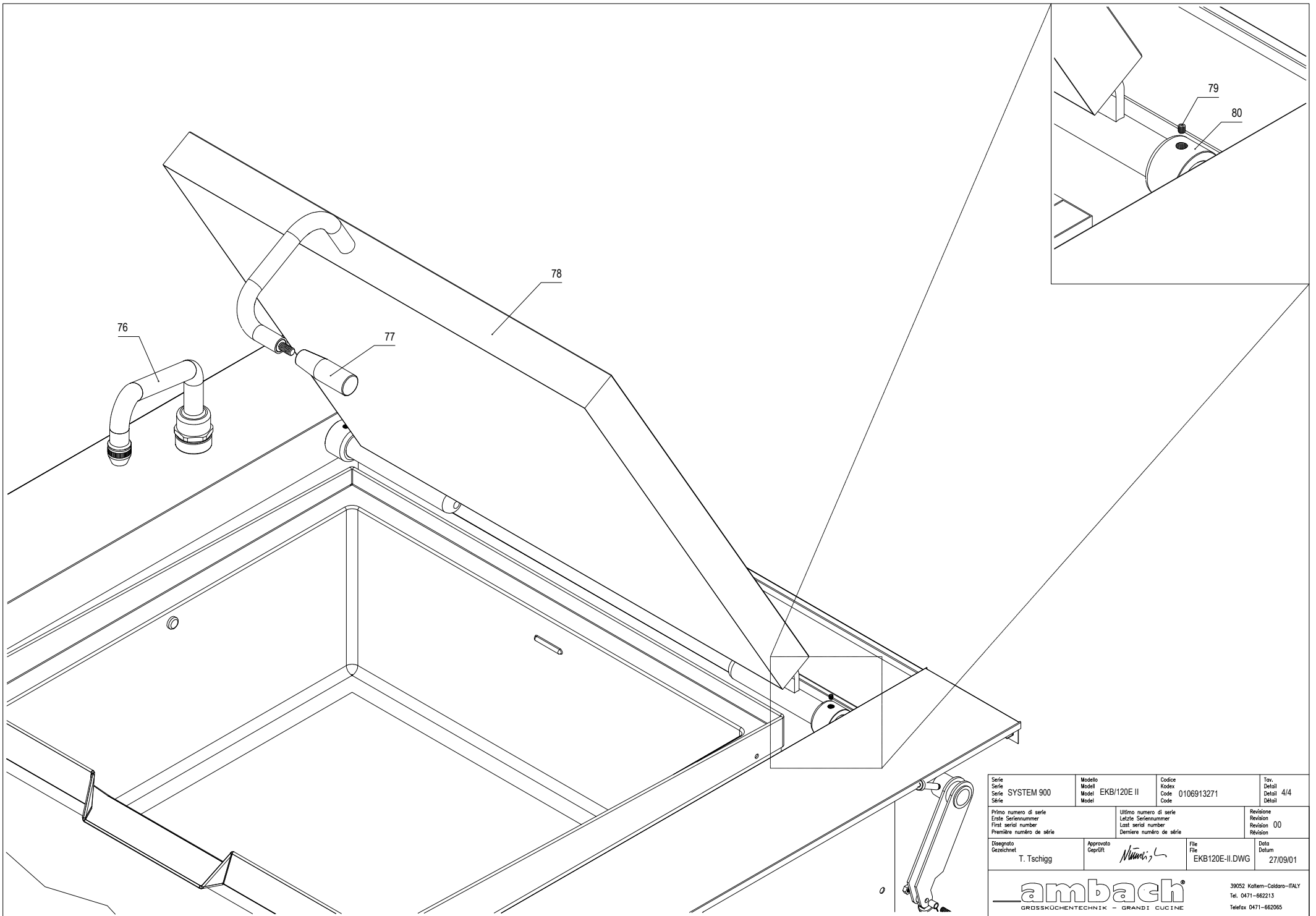

Serie Série Série	Modello Modell Model	Codice Kodex Code	Tav. Detail Détail
SYSTEM 900	EKB/120E II	0106913271	4/4
Primo numero di serie Erste Seriennummer First serial number Première numéro de série	Ultimo numero di serie Letzte Seriennummer Last serial number Dernière numéro de série	Revisione Revision Revision Révision	00
Disegnato Gezeichnet	Approvato Geprüft	File Date	Data Datum
T. Tschigg	<i>[Signature]</i>	EKB120E-II.DWG	27/09/01
			39052 Kallern-Caldaro-ITALY Tel. 0471-662213 Telefax 0471-662065

0106913271 Model: EKB/120E II

Elektro Kippbratpfanne mit elektronischer Steuerung
Electric tilting bratt pan with electronic adjustment

Brasiera elettrica con comandi elettronici
Sauteuse électrique avec réglage électronique

	Code	Beschreibung	Descrizione	Description	Désignation	St/Qty	Start	Finish	Serialnr.
1	5062808246	Transformator	Trasformatore	Transformer	Transformateur	KSKE/TPE/16	1		
2	5060513987	Erdungsklemme gelb/grün	Morsetto terra giallo/verde	Yellow/green ground terminal	Borne de terre jaune/verte	6QMM	5		
3	5060513984	Null-Leiterklemme blau	Morsetto neutro blu	Blue neutral terminal	Borne neutre bleue	6QMM	3		
		<i>Standard Version</i>	<i>Versione standard</i>	<i>Standard version</i>	<i>Standard Version</i>				
4	5060513981	Universalklemme grau	Morsetto universale grigio	Grey universal terminal	Borne universelle grise	6QMM	16		
		<i>Version RS485</i>	<i>RS485 versione</i>	<i>Version RS485</i>	<i>Version RS485</i>				
	5060513981	Universalklemme grau	Morsetto universale grigio	Grey universal terminal	Borne universelle grise	6QMM	19		
5	5060909759	Motorschutzschalter	Disgiuntore termico	Motor protection switch	Disjoncteur protection moteur	E-T-A 1A	1		
6	5061211324	Kondensator MFL	Condensatore MFL	Condenser MFL	Condensateur MFL	250V 6,3MF	1		
7	5050912346	Schützentstörfilter	Filtro antidisturbo	Radioshielding filter	Filtre antiparasites	130/240 V	3		
8	5061412528	Mechanische Verriegelung	Interblocco meccanico	Mechanical closing	Blocage mécanique		1		
9	5061411123	Schütz CGE CL02	Contattore CGE CL02	Contactore CGE CL02	Contacteur-disjonc. CGE CL02	A400T6AM	2		
10	5061407226	Schütz CGE CL25	Contattore CGE CL25	Contactore CGE CL25	Contacteur-disjonc. CGE CL25	A400T6AM 230 V	1		
11	5060513988	Erdungsklemme gelb/grün	Morsetto terra giallo/verde	Yellow/green ground terminal	Borne de terre jaune/verte	16QMM	1		
12	5060513982	Universalklemme grau	Morsetto universale grigio	Grey universal terminal	Borne universelle grise	16QMM	3		
13	5061807908	Sicherungshalter	Porta fusibile	Fuse holder	Porte-fusible	Siemens	1		
14	5060513985	Null-Leiterklemme blau	Morsetto neutro blu	Blue neutral terminal	Borne neutre bleue	16QMM	1		
15	5040302799	Mutter 6kt autobl.	Dado esa. autobloccante	Hexagon screw autobl.	Ecrou hexagonal autobloquant	M6	1		
16	5061816833	Sicherung	Fusibile	Fuse	Fusible	T1.6A 250V 5x20	1		
17	5041010295	Festklemmschraube 6kt	Dado serraggio candela	Nut clamp sparking plug	Ecrou bloquer bougie d'allumage	M6X12 INOX	1		
		<i>Standard Version</i>	<i>Versione standard</i>	<i>Standard version</i>	<i>Standard Version</i>				
18	3562916938	Hauptmodul + EPROM	Modulo principale + EPROM	Main modul + EPROM	Modul principal + EPROM		1		
		<i>Version RS485</i>	<i>RS485 versione</i>	<i>Version RS485</i>	<i>Version RS485</i>				
	3562917713	Hauptmodul + EPROM	Modulo principale + EPROM	Main modul + EPROM	Modul principal + EPROM		1		
		<i>Standard Version</i>	<i>Versione standard</i>	<i>Standard version</i>	<i>Standard Version</i>				
19	5062916941	Eprom Elektronische Steuerung	Eprom Centralina elettronica	Eprom Electronic control	Eprom Central électronique		1		
		<i>Version RS485</i>	<i>RS485 versione</i>	<i>Version RS485</i>	<i>Version RS485</i>				
	5062916935	Eprom Elektronische Steuerung	Eprom Centralina elettronica	Eprom Electronic control	Eprom Central électronique		1		
20	3509611373	Stift Spindelmotor	Perno attuatore	Pin spindle motor	Tige de moteur	KB/KK	1		
21	3001114985	Welle Spindelmotor	Perno attuatore	Pin spindle motor	Tourillon moteur actio. de bascu.	KB/KK	1		
22	3008915518	Lager Deckelhub	Cuscinetto coperchio	Cover bearing	Palier de couvercle	KB/KK	2		
23	5041810579	Zylinderspezialschraube	Vite tc cava es.	Hexagon cylinder screw	Vis à tête cylindrique spéciale	8x30 M6	1		
24	3506315542	Hebel Deckelhub	Leva coperchio	Cover lever	Levier de couvercle	KB/120	1		
25	5040310815	Mutter 6kt	Dado esagonale	Hexagon nut	Ecrou hexagonal	M6 Inox 18/8	2		
26	3027615545	Hülse Deckelhub	Boccola	Cover bush	Manchon de couvercle		2		
27	5041003117	Schraube 6kt	Vite te esagonale	Hexagon screw	Vis hexagonale	M6x25 Inox	2		
28	5061214601	Spindelmotor Catr33 200mm	Attuatore Catr33 200mm	Spindle motor Catr33 200mm	Moteur bascul. Catr33 200mm	33x200x1/220	1		
29	5060909748	Endschalter ATO-11-2-i	Finecorsa ATO-11-2-i	Limit switch ATO-11-2-i	Interrupteur fin de c. ATO-11-2-i	K&M	2		
30	5060909440	Anfahrrolle	Rotella + finecorsa	Starting pulley	Galet d'entraînement	ø13mm AR-ATO	2		
31	5001014949	Anschlag Endschalter oben	Battuta finecorsa superiore	Stopper limit switch above	Butée interrupteur fin de c. haut	KB/KK	1		
32	5001014947	Anschlag Endschalter unten	Battuta finecorsa inferiore	Stopper limit switch below	Butée interrupteur fin de c. bas	KB/KK	1		
33	3006314960	Halter Anschläge Motor	Supporto cammes	Motor stroke holder	Support butée de moteur	KB/KK	1		
34	5061214600	Gabel für Spindelmotor	Forcella anteriore	Force for spindle motor	Fourche moteur de bascule.	Catr33	1		
35	3001115561	Schraube Spindelmotor	Vite per rubinetto monoforo	Screw for water filling cock	Vis robinet d'alimentation d'eau	KB/KK	1		

0106913271 Model: EKB/120E II

Elektro Kippbratpfanne mit elektronischer Steuerung
Electric tilting bratt pan with electronic adjustment

Brasiera elettrica con comandi elettronici
Sauteuse électrique avec réglage électronique

Code	Beschreibung	Descrizione	Description	Désignation	St/Qty	Start	Finish	Serialnr.
36	3027615533	Hülse Schraube Spindelmotor	Boccola vite attuatore	Bush screw spindle motor	Manchon vis moteur	KB/KK		1
37	5040310957	Mutter 6KT Autobl.	Dado esa. autobloccante	Hexagon screw autobl.	Ecrou hexagonal autobloquant	M12 INOX 18/8		2
38	3506315119	Halter Welle Wanne rechts	Supporto asse destro	Right shaft holder basin	Support d'axe de cuve droite	KB/KK/SYSTEM		1
39	5040003847	Nutmutter	Ghiera di bloccaggio	Groove nut	Ecrou cylindrique à encoches	M 80x2		2
40	5008505691	Kugellager	Cuscinetto a sfera	Ball bearing	Roulement à billes	6016-2RS		2
41	5041402628	Zylinderschraube in. 6kt	Vite tcei	Hexagon cylinder screw	Vis cylindrique hexagonale	M8x20 Inox		8
42	5062916945	Vertikales Bedienungsteil	Scheda comandi verticale	Vertical control unit	Élément de commande vertical			1
43	5060919758	Kontaktelement	Contatti	Contact element	Élément de contact	N.A. TP/KSK		2
44	5061119760	Lampenelement	Elemento lampada	Lamp element	Élément de lampe	TP/KSK		1
45	5061103274	Glimmlampe Neon	Lampada spia neon	Neon control lamp	Lampe de contrôle au néon	BA 9S 220V		1
46	5060919759	Halter Kontaktelement	Basetta portacontatti	Contact element holder	Support d'élément de contact	TP/KSK		1
47	5060919757	Druckschalter beleuchtet	Pulsante passo passo	Pressing switch lighting	Bouton poussoir lumineux	TP/KSK		1
48	3511817033	Zusammenbau Schaltblende	Assieme cruscotto	Control panel assembly	Assembler panneau de com.			1
49	5061616223	Sicherheitsthermostat	Termostato limitatore	Safety thermostat	Thermostat de sécurité	KB/BP		1
50	5040800776	Gewindestift innen 6kt	Perno filettato esagonale	Hex-socket set screw	Vis hexagonale sans tête	M6x40 INOX		32
51	5040801551	Gewindestift Inox	Perno filettato inox	Inox set screw	Vis sans tête en inox	M6x80mm		4
52	5040202769	Beilagscheibe	Rondella	Washer	Rondelle de calage	D=6,4 INOX		36
53	5040310815	Mutter 6kt Inox	Dado esagonale inox	Hexagon inox nut	Ecrou hexagonal en inox	M6		72
54	5006801972	Isolierung Durablanket	Isolazione interna "Cerapaper"	Internal insulation "Cerapaper"	Calorifugeage int. "Cerapaper"	128x1" KG/MC		
55	3006713353	Isolierblech außen	Lamiera isolante esterna	External insulation plate	Tôle isolante extérieure	EKB/120E II		1
56	5060817107	Heizkörper 1500W 400V	Resistenza 1500W 400V	Heating element 1500W 400V	Résistance 1500W 400V	EKBD		9
57	5006317351	Halter Heizkörper	Supporto resistenza	Heating element holder	Support de résistance	EKBD		7
58	5006317367	Halter Heizkörper	Supporto resistenza	Heating element holder	Support de résistance	EKBD		2
59	5011810838	Tastaturfolie	Mascherina scheda	Keyboard foil	Membrane protec. de clavier	ESK/GNKE/E II		1
60	5061809773	Sicherung	Fusibile	Fuse	Fusible	8A TPME/KKME		1
61	3506315118	Halter Welle Wanne links	Supporto asse sinistro	Left shaft holder basin	Support d'axe de cuve gauche	KB/KK/SYSTEM		1
62	3027615534	Hülse Schraube Feder	Boccola vite molla	Bush screw spring	Manchon vis ressort	KB/KK		1
63	5041010377	Schraube 6kt	Vite te esagonale	Hexagon screw	Vis hexagonale	M12x50 INOX 18/8		1
64	3006315590	Halter Feder vorne	Supporto molla anteriore	Spring holder in front	Support de ressort avant	KB/KK		1
65	5004715273	Zugfeder Kipper	Molla reazione brasiera	Driving spring tilting	Ressort de traction basculem.	KB/EKK		1
66	5009614955	Stift Feder	Perno molla	Spring pin	Goupille de ressort	KB/KK		1
67	5006310539	Halter Feder Inox	Supporto molla inox	Spring holder inox	Support de ressort en inox	M10		1
68	5024612524	Flexibler Stahlschlauch	Tubo flessibile	Flexible steel tube	Tuyau flexible en acier	L=500		1
69	5051101294	T-Stück Messing 1/2" W+M/M	T ottone 1/2" F+M/M	T brass 1/2" F+M/M	Pièce en T en laiton 1/2" F+M/M	Art. 463		1
70	5050101267	Bogen Messing M+W	Angolo ottone M+F	Elbow brass M+F	Raccord coudé en laiton M+F	1/2" Art. 458		2
71	5018106153	Elektroventil 1/2"	Elettrovalvola 1/2"	Electric valve 1/2"	Electrovanne 1/2"	KMG/KME/50		2
72	5051001287	Doppelnippel Messing	Nipplo doppio ottone	Double nipple brass	Double raccord en laiton	1/2" Art.441		2
73	5050915915	Filter in Messing	Filtro in ottone	Brass filter	Filtre en laiton	1/2"		2
74	5024612525	Flexibler Stahlschlauch	Tubo flessibile	Flexible steel tube	Tuyau flexible en acier	L=900		2
75	5050909752	Schützentstörfilter	Filtro antisturbo	Radioshielding filter	Filtre antiparasites	400 V		2
76	5000510477	Rohr Schwenkarm	Getto erogazione acqua	Swivel arm tube	Tuyau à bec orientable	EKB/GKB/150		1
77	5005607080	Griff Deckel	Maniglia coperchio	Cover handle	Poignée de couvercle	M 10 KSK		1
78	3503118186	Deckel	Coperchio	Cover	Couvercle	KB/120		1

0106913271 Model: EKB/120E II

Elektro Kippbratpfanne mit elektronischer Steuerung
Electric tilting bratt pan with electronic adjustment

Brasiera elettrica con comandi elettronici
Sauteuse électrique avec réglage électronique

	Code	Beschreibung	Descrizione	Description	Désignation	St/Qty	Start	Finish	Serialnr.
79	5040811648	Gewindestift innen 6kt	Perno filettato esagonale	Hex-socket set screw	Vis hexagonale sans tête	M5x6 Inox	2		
80	3027615510	Hülse Abdeckung Welle	Boccola alzacoperchio	Bush shaft protection	Manchon protecteur axe	KB/120/150	2		
81	3511817693	Zusammenbau Schaltblende	Assieme cruscotto	Control panel assembly	Assembler panneau de com.		1		