

# CU0515GA Service Parts

This is the list of service parts for the CU515GA ice machine.

When ordering a part, be sure to confirm that the part is for the correct model.

## Table of Contents

Cabinet . . . . .	Page 2
Refrigeration System . . . . .	Page 3
Water System . . . . .	Page 4
Control System . . . . .	Page 5

# CU0515GA Service Parts

## Cabinet

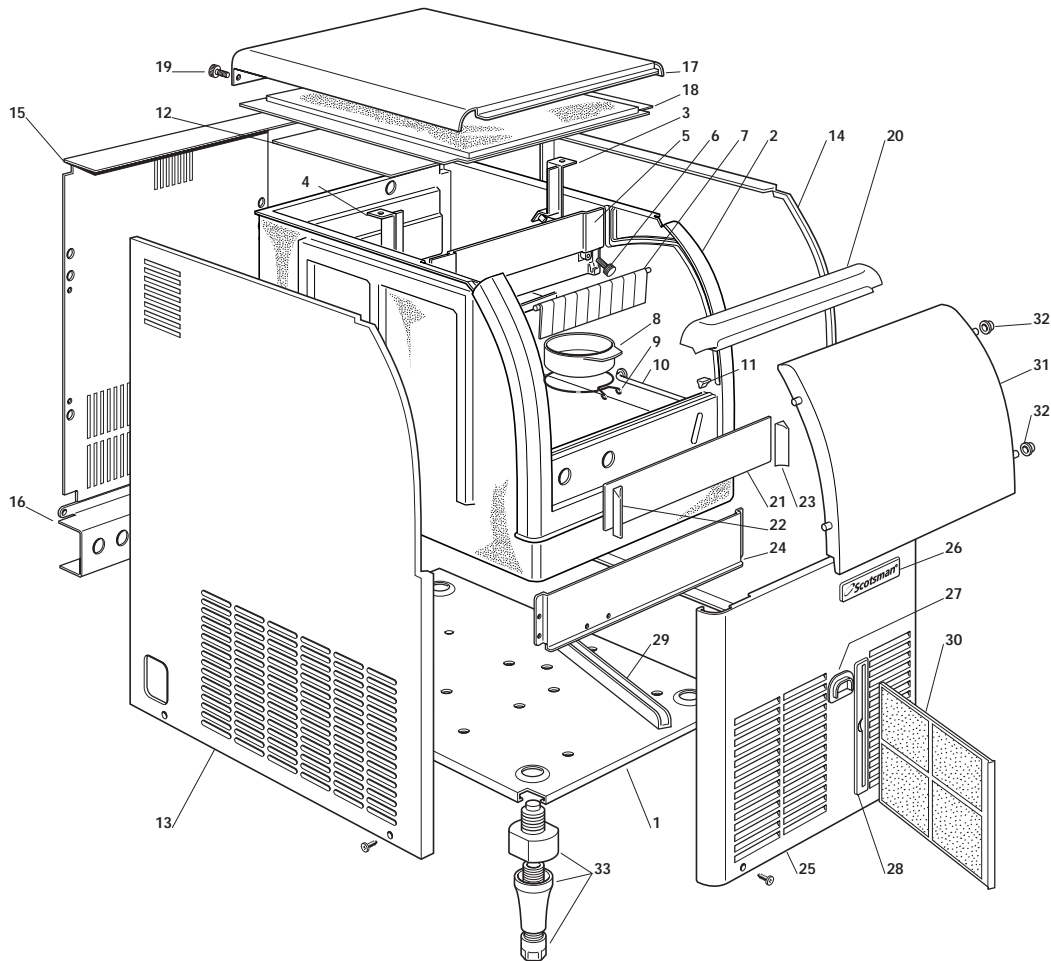

Item Number	Part Number	Description	Item Number	Part Number	Description
1	F702458-00	Unit Base	17	F781467-00	Insulated Top Panel
2	F782101-02R	Insulated Storage Bin	19	F650806-00	Thumb Screw
3	F660778-00	Curtain Bracket Right	20	F660776-00	Front Liner
4	F660778-01	Curtain Bracket Left	21	F721970-00	Front Plate
5	F660775-00	Curtain Bracket Upper	22	F660830-01	Corner Protection Left
6	F650806-05	Thumb Screw	23	F660830-00	Corner Protection Right
7	F784457-07R	Curtain assy	24	F702402-00	Bracket, Front
8	F660741-00	Plastic Plug	25	F722249-00	Panel, Front
9	F460047-00	Spring	26	F650850-00	Logo, Scotsman
10	F732017-00	Bulb Holder	27	F660829-00	Front Switch Plastic Protection
11	F660816-00	Shock Absorber	28	F660804-00	Air Filter Seat
12	F742033-00	Evaporator Cover	29	F660817-00	Slide, Air Filter
13	F722248-00	Panel, Left Side	30	F660805-00	Air Filter
14	F722247-00	Panel, Right Side	31	F660814-00	Bin Door
15	F702457-00	Panel, Rear	32	F660286-00	Bushing
16	F702462-00	Bracket	33	F650670-05	Legs Kit

# CU0515GA Service Parts

## Refrigeration System

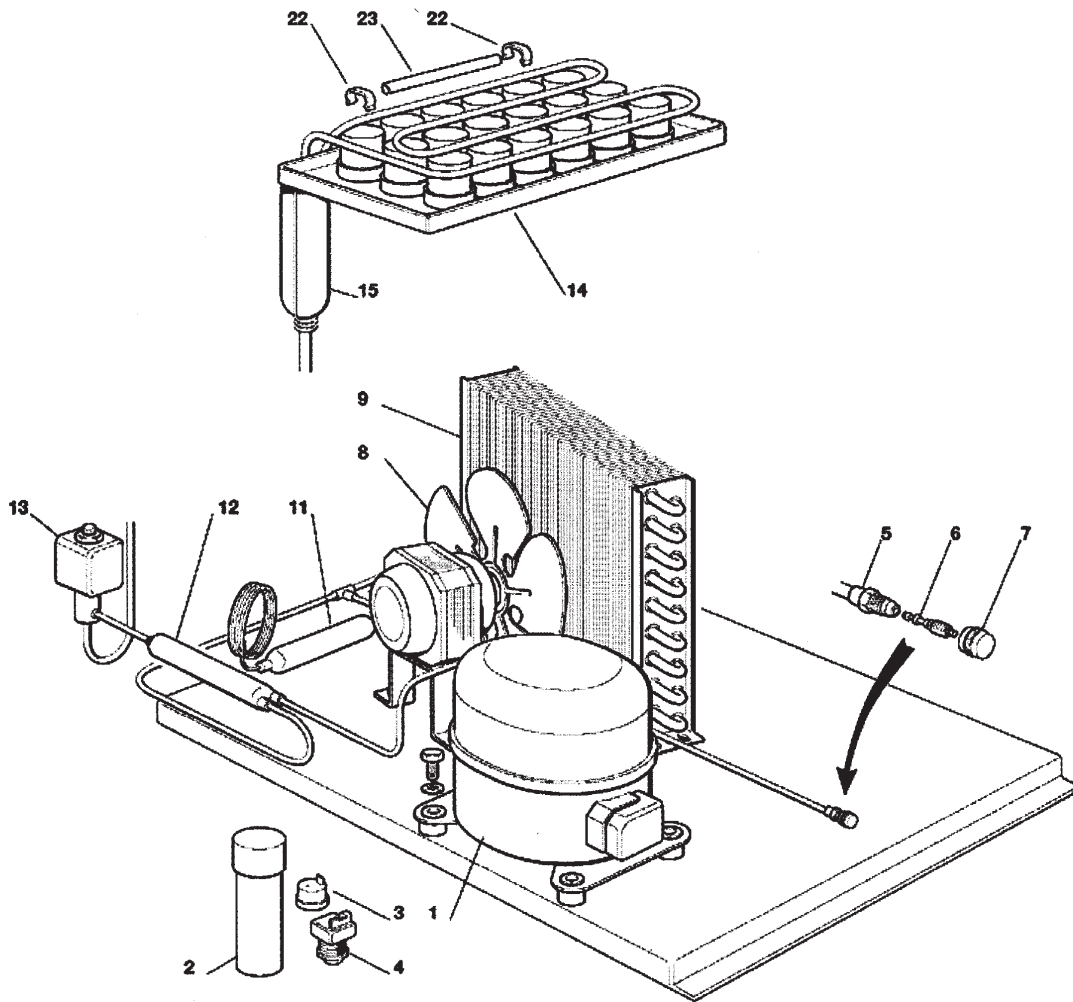

Item Number	Part Number	Description	Item Number	Part Number	Description
1	F670100-06	Compressor	12	F630137-00	Mechanical Filter
2	F620167-48	Start Capacitor	13	F620306-27	Hot Gas Valve Body
3	F620058-97	Protector	13a	F620306-51	Coil
4	F620057-66	Relay	14	F784615-01	Evaporator assy
5	F650109-00	Valve Body	15	F784632-01	Suction Line assy
6	F670012-00	Valve Core	22	F650475-02	Metal Clip
7	F650106-00	Cap	23	F741114-00R	Bulb Holder
8	F620419-03	Fan Motor			
8a	F620419-32	Fan Blade			
9	F620420-00	Condenser			
11	F630003-05	Filter			

# CU0515GA Service Parts

## Water System

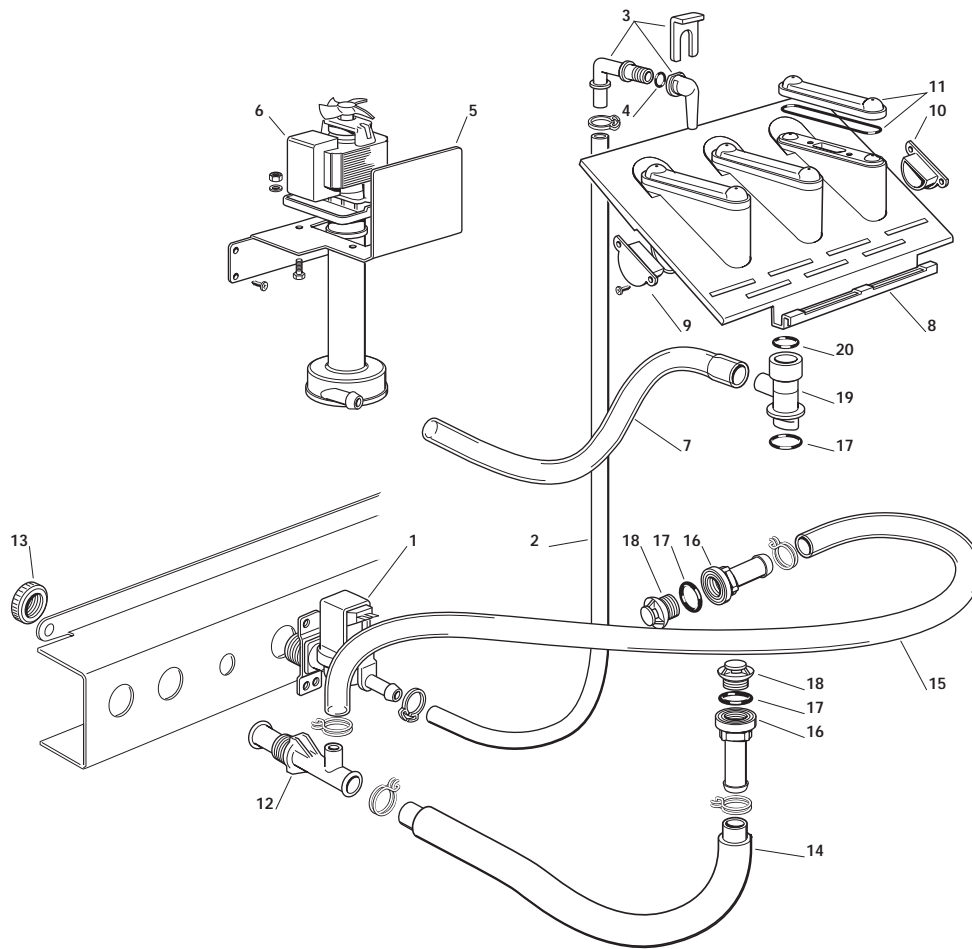

Item Number	Part Number	Description	Item Number	Part Number	Description
1	A32405-001	Water Inlet Valve	15	F610204-00	Tube
1a	F640022-06	Flow Control	16	F660219-02	Bin Drain
2	F281900-04	Tube, per meter	17	F640134-00	O Ring
3	F793172-00R	Water Inlet Elbow assy	18	F660211-01	Drain Filter
4	F640041-31	O Ring	19	F660777-00	Spray System Seat
5	F724417-00	Metal Bracket	20	F640041-32	O Ring
6	A32588-020	Water Pump			
7	F610150-04	Tube			
8	F793129-09	Spray System assy			
9	F660520-07	Plastic Plug			
10	F660520-06	Plastic Plug			
11	F060529-01	Spray Cover Kit			
12	F660224-00	Tee Tube			
13	F660535-00	Plastic Nut			
14	F610148-10	Tube			

# CU0515GA Service Parts

## Control System

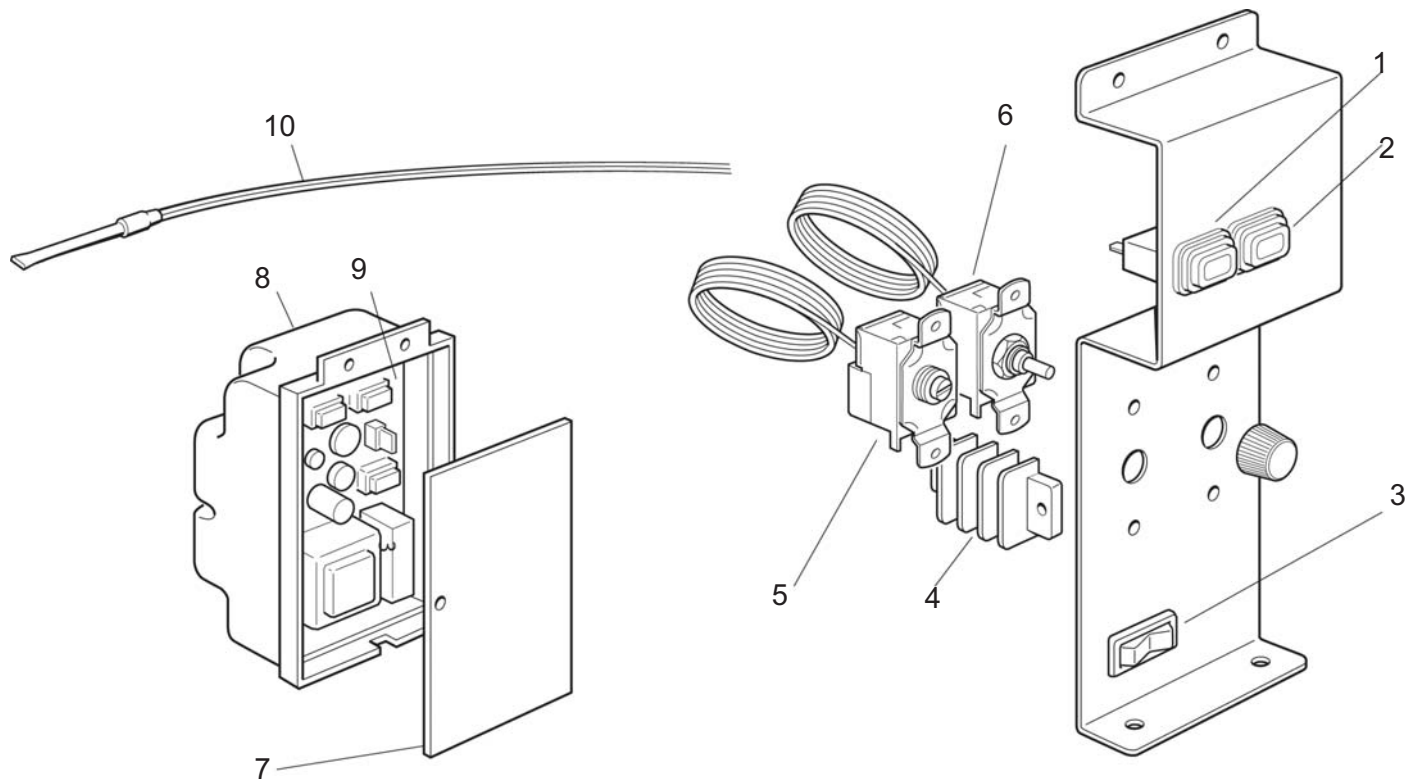

Item Number	Part Number	Description
1	F620487-01	Warning Light - Reset Button
2	F620487-00	Master Lighted Switch
3	F620442-01	Switch
4	F630114-01	Terminal Board
5	F630005-00	Bin Thermostat
6	F620264-11	Evap. Thermostat
7	F702464-00	Cover
8	F702463 00	Metal Control box
9	F620496-00	PC Board - Cleaning Remind
10	F620404-11	Condenser Sensor

# CU0515GA Service Parts

## Wiring Diagram

