

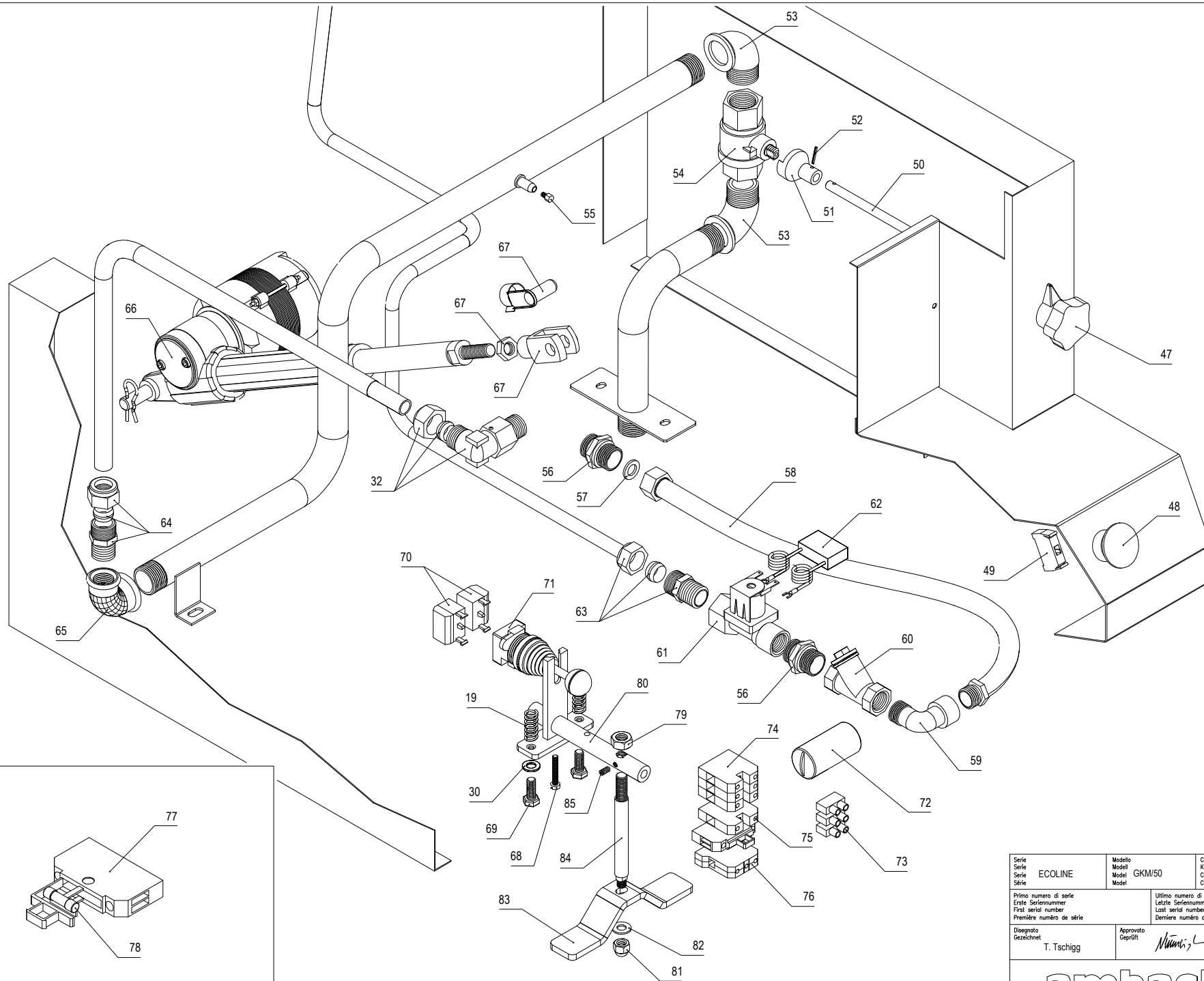

Serie Serie Série	Modello Modell Model	Codice Kodex Code	Tav. Detail Détail
ECOLINE	GKM/50	0106915378	A
Primo numero di serie Erste Seriennummer First serial number Première numéro de série	Ultimo numero di serie Letzte Seriennummer Last serial number Dernière numéro de série	Revisione Revision Révision	00
Disegnato Gezeichnet	Approvato Geprüft	File Datei	Data Datum
T. Tschigg	<i>[Signature]</i>	GKM50.DWG	06/09/01
ambach <small>GROSSKÜCHENTECHNIK - GRANDI CUCINE</small>			<small>39052 Kattem-Caldaro-ITALY Tel. 0471-662213 Telefax 0471-662065</small>



Serie Série Série Série	Modello Model Model Model	Codice Kodex Code Code	Tav. Detail Detail Detail
ECOLINE	GKM/50	0106915378	B
Primo numero di serie Erste Seriennummer First serial number Première numéro de série	Ultimo numero di serie Letzte Seriennummer Last serial number Dernière numéro de série	Revisione Revision Revision Révision	00
Disegnato Gezeichnet	Approvato Geprüft	File Datei	Data Datum
T. Tschigg		GKM50.DWG	06/09/01
			39052 Kattem-Caldaro-ITALY Tel. 0471-662213 Telefax 0471-662065

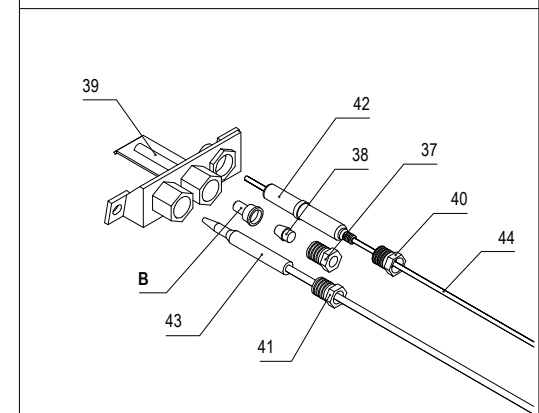
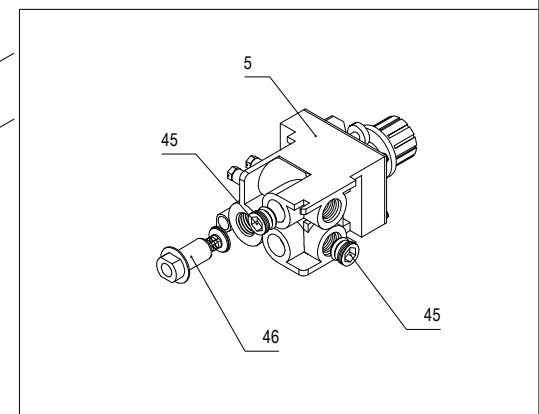
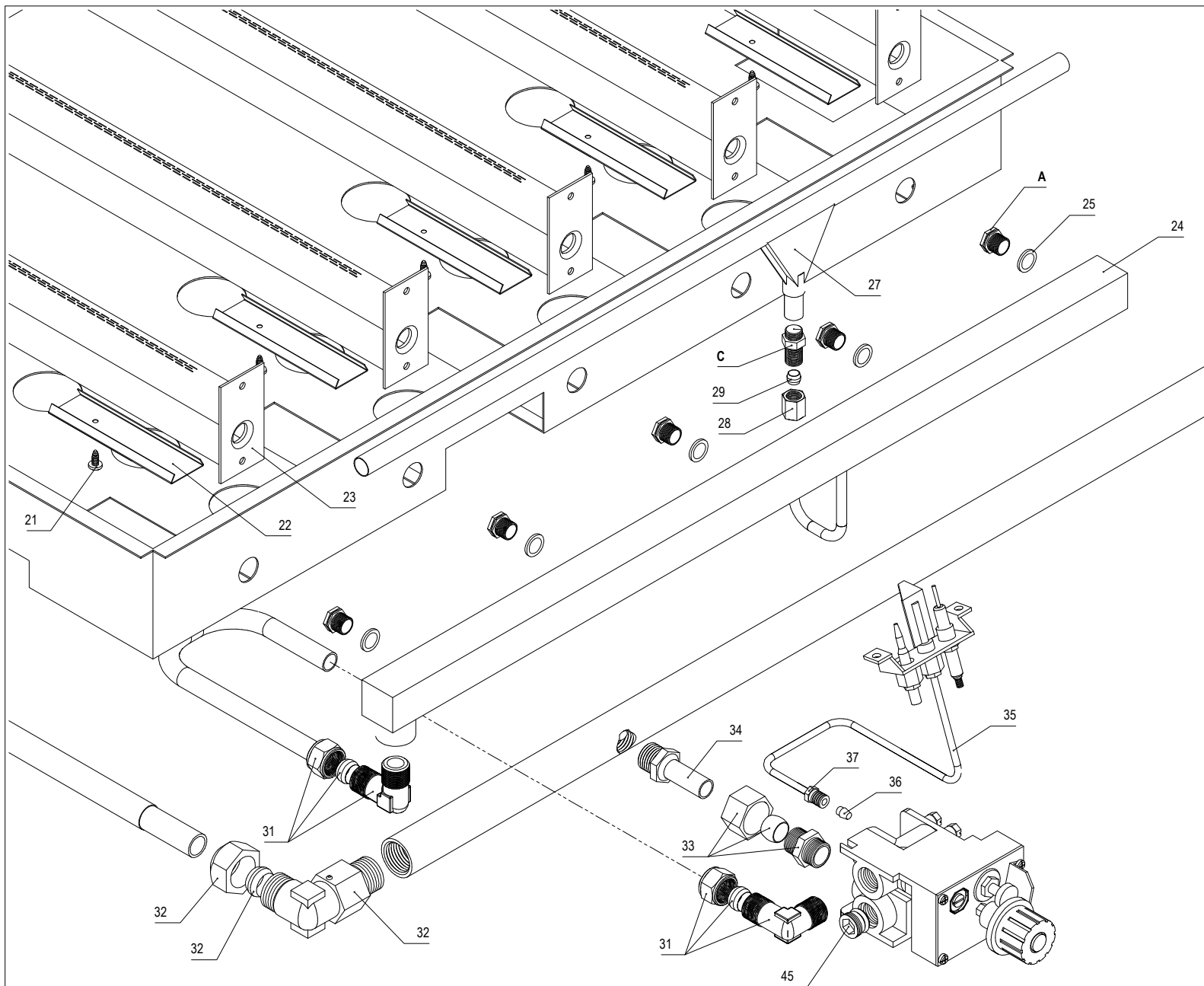

Serie Série Série Série	Modello Modell Model Model	Codice Kodez Code Code	Tav. Detail Detail Detail
ECOLINE	GKM/50	0106915378	C
Primo numero di serie Erste Seriennummer First serial number Première numéro de série	Ultimo numero di serie Letzte Seriennummer Last serial number Dernière numéro de série	Revisione Revision Revision Révision	00
Disegnato Gezeichnet	Approvato Geprüft	File File	Data Datum
T. Tschigg		GKM50.DWG	06/09/01

0106915378 Model: GKM/50

Gas Kippbratpfanne - Motorkippung

Gas tilting bratt pan - motor tilting

Brasiera a gas - ribaltamento a motore

Sauteuse basculant à gaz - basculement motorisé

	Code	Beschreibung	Descrizione	Description	Désignation		St/Qty	Start	Finish	Serialnr.
1	3507813245	Kamin	Camino lungo	Chimney long	Cheminée long	GKM/GKH/50-90	1			
2	3512007072	Scharnier Deckel	Cerniera coperchio	Cover hinge	Charnière de couvercle	KB/50/90	1			
3	3503112001	Deckel doppelwandig	Coperchio + controbombato	Double walled cover	Couvercle à double paroi	KB/50	1			
	3003103671	Deckel doppelwandig	Coperchio + controbombato	Double walled cover	Couvercle à double paroi	KB/50	1		27/03/98	
4	5060408640	Piezozünder	Accensione piezo	Piezo lightning	Allumeur piézo-électrique	PZ 10006	1			
5	3518912246	Gasventil Eurosit + Blindstopfen	Valvola gas Eurosit	Gas valve Eurosit	Soupape à gaz Eurosit		1			
6	5040400972	Hutmutter Inox	Dado es. cieco inox	Hexagonal nut inox	Ecrou borgne en inox	M16 UNI5721	1			
7	5041403131	Zylinderschraube in. 6kt	Vite tcei	Hexagon cylinder screw	Vis cylindrique hexagonale	M6x20 INOX	4			
8	3008907147	Lager Deckelhub links	Supporto coperchio sinistra	Left cover bearing	Palier de couvercle gauche	KB/50/90	1			
9	3008907148	Lager Deckelhub rechts	Supporto coperchio destra	Right cover bearing	Palier de couvercle droite	KB/50/90	1			
10	5040802792	Gewindestift innen 6kt	Perno filettato esagonale	Hex-socket set screw	Vis hexagonale sans tête	M6x16 INOX	1			
11	3009606853	Stift Anschlag Deckel	Perno battuta coperchio	Cover thrust pin	Goupille butée de couvercle	KB/50/90	2			
12	5040202638	Beilagscheibe	Rondella	Washer	Rondelle de calage	D=10,4 INOX	2			
13	5041002641	Schraube 6kt	Vite te esagonale	Hexagon screw	Vis hexagonale	10x20 - Inox 18/8	2			
14	3001107074	Welle Deckelhub	Asse alzacoperchio	Shaft cover lifting	Axe pour levage du couvercle	KB/50/90	1			
15	3001106196	Welle Feder links	Asse molla sinistra	Shaft left spring	Axe de ressort gauche	KB/50/90	1			
16	3001106197	Welle Feder rechts	Asse molla destra	Shaft right spring	Axe de ressort droite	KB/50/90	1			
17	5004707073	Feder Deckelhub	Molla alzacoperchio	Spring cover lifting	Ressort pour levage couvercle	KB/50/90	1			
18	5040320713	Gegenmutter Messing	Controdado ottone	Bas counter nut	Contre-écrou laiton	1/2" FIG 310	1			
19	5004704628	Feder Kippung	Molla ribaltamento	Tilting spring	Ressort dispos. de basculement	KMG/50	2			
20	5051206145	Konus-Quetschverschraubung	Dado adattatore di pressione	Pressure adapter nut	Ecrou adaptateur de pression	1/2x12	1			
21	5041703368	Zylinderschraube	Vite tc	Cylinder screw	Vis à tête cylindrique	KSL 3,9x9,5	5			
22	3010002581	Regulierblech Luft	Lamiera regolazione aria	Air regulation plate	Tôle de régulation d'air	GG	5			
23	5016901907	Brenner 239/10 500mm	Brucciatoe 239/10 500mm	Burner 239/10 500mm	Brûleur 239/10 500mm	GG/40/V	5			
24	5002211640	Brennerrampe	Rampa bruciatoe	Burner rail	Brûleur à rampe	GKM/50	1			
25	5017302671	Dichtung Aluminium	Guarnizione alluminio	Aluminium seal	Joint d'étanchéité en aluminium	10x14x1,5	5			
26	5029406192	Wassereinlauf 1/2"	Getto d'acqua 1/2"	Water inlet 1/2"	Alimentation d'eau 1/2"	KB/50/90	1			
27	5020311641	Zündbrücke 572mm	Rampa accensione 572mm	Ignition bridge 572mm	Rampe d'interallumage 572mm	GKM/50	1			
28	5040603226	Überwurfmutter 6kt	Dado pilota termocoppia	Nut thermocouple	Ecrou-raccord thermocouple	M10x1-6	1			
29	5050503194	Doppelkegelring Messing	Bicono	Olive	Joint bicon.	MS D=6	1			
30	5040202678	Beilagscheibe verzinkt	Rondella ferro zincato	Zinc washer	Rondelle de calage zinguée	D=8,4x17	2			
31	5051204005	Winkelverschraubung	Raccordo a gomito	Angle fitting	Raccord à vis coudé	3/8">12	2			
32	4551207219	Winkelgelenk	Raccordo gomito girevole	Angle joint	Raccord coudé pivotant	26 421 R 1/2"	1	17/02/98		608008
33	5051220038	Rohrverschraubung Messing	Raccordo ottone	Brass pipe union	Raccord vissé en laiton	MS 3/8">12	1			
34	5051211619	Verschraubung spezial	Colleg. indicatore termocoppia	Conn. thermocouple indication	Raccord indic. thermocouple	GKM	1			
35	5000511631	Rohr Zündbrenner	Tubo pilota	Pilot burner tube	Tuyau de veilleuse	GKM	1			
36	5050503573	Doppelkegelring Pilot	Bicono pilota tubo	Olive pilot pipe	Joint bicon. tuyau de veilleuse	PeI D=4	1			
37	5040603572	Überwurfmutter	Dado	Nut	Ecrou-raccord	PeI D=4	1			
38	5050506686	Doppelkegelring Pilot	Bicono pilota tubo	Olive pilot pipe	Joint bicon. tuyau de veilleuse	MS D=4	1			
39	5024706878	Zündbrenner 3 Weg 4mm	Brucciatoe pilota 3 vie 4mm	Pilot burner 3 ways 4mm	Brûleur de veilleuse 3voies 4mm	ZG/GG	1			
40	5040317235	Festklemmmutter Zündkerze	Dado serraggio termocoppia	Nut clamp thermocouple	Ecrou bloquer thermocouple		1			

0106915378 Model: GKM/50

Gas Kippbratpfanne - Motorkippung
Gas tilting bratt pan - motor tilting

Brasiera a gas - ribaltamento a motore
Sauteuse basculant à gaz - basculement motorisé

	Code	Beschreibung	Descrizione	Description	Désignation	St/Qty	Start	Finish	Serialnr.
41	5040306819	Festklemmmutter Thermoelem.	Vite zigrinata	Hexagon screw clamp	Ecrou bloquer hexagonal	FG	1		
42	5062606677	Zündkerze rund	Candela accensione rotonda	Round sparking plug	Bougie d'allumage ronde	GY/GF	1		
43	5024110057	Thermofühler 400mm	Termocoppia 400mm	Thermocouple 400mm	Thermocouple 400mm	GBP/GP/45/90	1		
44	5061003550	Kabel Zündung	Cavo accensione	Ignition cable	Câble d'allumage	740 S/85	1		
45	5050200943	Blindstopfen Eurosit	Tappo Eurosit	Capscrew Eurosit	Tampon borgne Eurosit	3/8"	2		
46	5029715229	Magneteinsatz	Inserito magnetico	Magnet insert	Joint magnétique	630 EUROSIT	1		
47	5022902035	Schaltknopf Absperrhahn	Manopola chiusura	Insulating cock knob	Bouton de robinet d'arrêt	G/85	1		
48	5018611265	Schalttaster	Pulsantiera	Push button	Commutateur	KB/50/90	1		
49	5060911266	Schaltkontakt	Contatto cema	Switch push button contact	Interrupteur contact	KB/50/90	1	29/09/97	540006
50	3501108387	Welle Absperrhahn	Asta rubinetto gas	Shaft insulation cock	Axe de robinet d'arrêt	KMG/50	1		
51	5006309520	Halter Welle Absperrhahn	Prolunga asta rubinetto gas	Shaft insulation cock holder	Support axe de robinet d'arrêt	ECO	1		
52	5009401188	Spannhülse	Spina elastica	Adapter sleeve	Douille de serrage	D=3x16	1		
53	5050120703	Bogen Messing	Gomito ottone	Elbow brass	Raccord coudé en laiton	Fig. 92 3/4"	2		
54	5018009540	Kugelventil 3/4"	Valvola a sfera 3/4"	Ball valve 3/4"	Soupape sphérique 3/4"	V/1000 FF	1		
55	5041001080	Druckmeßschraube	Vite presa pressione	Pressure take-off screw	Vis de pression	SR 70 25	1		
56	5051001287	Doppelnippel Messing	Nipplo doppio ottone	Double nipple brass	Double raccord en laiton	1/2" ART.441	2		
57	5017313786	Dichtung Wasserschlauch	Guarnizione tubo flessibile	Water flexible tube seal	Joint d'étanch. tuyau flexible eau	1/2"	1		
58	5024612524	Flexibler Stahlschlauch	Tubo flessibile	Flexible steel tube	Tuyau flexible en acier	1/2x1/2x50	1		
59	5050101267	Bogen Messing M+W	Angolo ottone M+F	Elbow brass M+F	Raccord coudé en laiton M+F	1/2" Art. 458	1	07/12/99	749022
60	5050915915	Filter in Messing	Filtro in ottone	Brass filter	Filtre en laiton	1/2"	1		
61	5018106153	Elektroventil 1/2"	Elettrovalvola 1/2"	Electric valve 1/2"	Electrovanne 1/2"	KMG/KME/50	1		
62	5050909752	Schützentstörfilter	Filtro antidisturbo	Radioshielding filter	Filtre antiparasites	400 V	1		
63	5051220032	Rohrverschraubung gerade	Raccordo diritto	Straight pipe union	Raccord droit vissé	MS 1/2">12	1		
64	5051220023	Rohrverschraubung Messing	Raccordo ottone	Brass pipe union	Raccord vissé en laiton	MS 1/2">16	1		
65	5050100138	Bogen verzinkt Fig. 90	Gomito zincato fig. 90	Elbow zinc fig. 90	Raccord coudé zingué fig. 90	3/4">1/2"	1		
66	5061214801	Spindelmotor 150mm 220V	Attuatore 150mm 220V	Spindle motor 150mm 220V	Moteur de bascul. 150mm 220V	33x150x1	1		
67	5061214600	Gabel für Spindelmotor	Forcella anteriore	Force for spindle motor	Fourche moteur de bascule.	Catr33	1		
68	5041816834	Zylinderschraube	Vite tc	Cylinder screw	Vis à tête cylindrique	M5x30 Inox	1	07/12/99	749022
69	5041002681	Schraube 6kt	Vite te esagonale	Hexagon screw	Vis hexagonale	M8x20 KL8.8	1		
70	5060902730	Kontakte 300V V50	Contatti 300V V50	Contacts 300V V50	Contacts 300V V50	KB/50	2		
71	5060901909	Schalter Breter	Manipolatore Breter	Breter switch	Interrupteur Breter	KB/50	1		
72	5061211324	Kondensator MFL	Condensatore MFL	Condenser MFL	Condensateur MFL	250V 6,3MF	1		
73	3560510381	Anschlußklemme 3P	Morsettiera 3P	Connection terminal 3P	Borne de raccordement 3P	PA/44 Sez-4	1		
74	5060513981	Universalklemme grau	Morsetto universale grigio	Grey universal terminal	Borne universelle grise	6QMM	3		
75	5060513984	Null-Leiterklemme blau	Morsetto neutro blu	Blue neutral terminal	Borne neutre bleue	6QMM	1		
76	5060513987	Erdungsklemme gelb/grün	Morsetto terra giallo/verde	Yellow/green ground terminal	Borne de terre jaune/verte	6QMM	2		
77	5061807908	Sicherungshalter	Porta fusibile	Fuse holder	Porte-fusible	Siemens	1		
78	5061807231	Glassicherung 01078 250V	Fusibile 01078 250V	Fuse 01078 250V	Fusible 01078 250V	Flink 5x20 6,3A	2		
79	5040302606	Mutter 6kt Inox	Dado esagonale inox	Hexagon inox nut	Ecrou hexagonal en inox	M10 18/8	2		
80	3001106194	Welle Pedal	Asta pedale	Pedal shaft	Axe de pédale	KB/50	1		
81	5040402696	Hutmutter Inox	Dado es. cieco inox	Hexagonal nut inox	Ecrou borgne en inox	M8 A2 18/8	1		

0106915378 Model: GKM/50

Gas Kippbratpfanne - Motorkippung**Gas tilting bratt pan - motor tilting****Brasiera a gas - ribaltamento a motore****Sauteuse basculant à gaz - basculement motorisé**

	Code	Beschreibung	Descrizione	Description	Désignation		St/Qty	Start	Finish	Serialnr.
82	5040202637	Beilagscheibe	Rondella	Washer	Rondelle de calage	D=8,4 INOX	1			
83	3004605624	Pedal	Pedale	Pedal	Pédale	KB/50	1			
84	3001106195	Halter Pedal	Supporto pedale	Pedal holder	Support de pédale	KB/50	1			
85	5040802791	Gewindestift innen 6kt	Perno filettato esagonale	Hex-socket set screw	Vis hexagonale sans tête	M5x12	1			
		<i>Düsentabellen siehe Bedienungsanleitung</i>	<i>Tabella ugelli vedi manuale d'installazione e d'uso</i>	<i>Jet chart see instruction manual</i>	<i>Tableau des gicleurs voir notice d'emploi et d'entretien</i>					
A		Brennerdüse	Ugello bruciatore	Burner jet	Gicleur de brûleur		1			
B		Zündbrennerdüse	Ugello bruciatore pilota	Pilot burner jet	Gicleur du brûleur de veilleuse		1			
C		Zündbrückendüse	Ugello rampa interaccensione	Ignition bridge jet	Gicleur rampe d'interallumage		1			