

CME500R SERVICE PARTS

This section contains the parts illustrations and parts lists for the CME500R.

A "no number" designation, when found in the part number column, indicates the part in question is not available from Scotsman as an assembly. This designation is used only for clarity in making the list.

When ordering parts, to avoid costly delays and errors, give the part number, the complete description as shown in the list, and the quantity of each part or assembly required.

TABLE OF CONTENTS

Exterior Panels	2
Interior Panels	3
Refrigeration System	4
Water System	5
Control Box	6
Remote Condenser	7
Wiring Diagrams	8

CME500R SERVICE PARTS CABINET ASSEMBLY

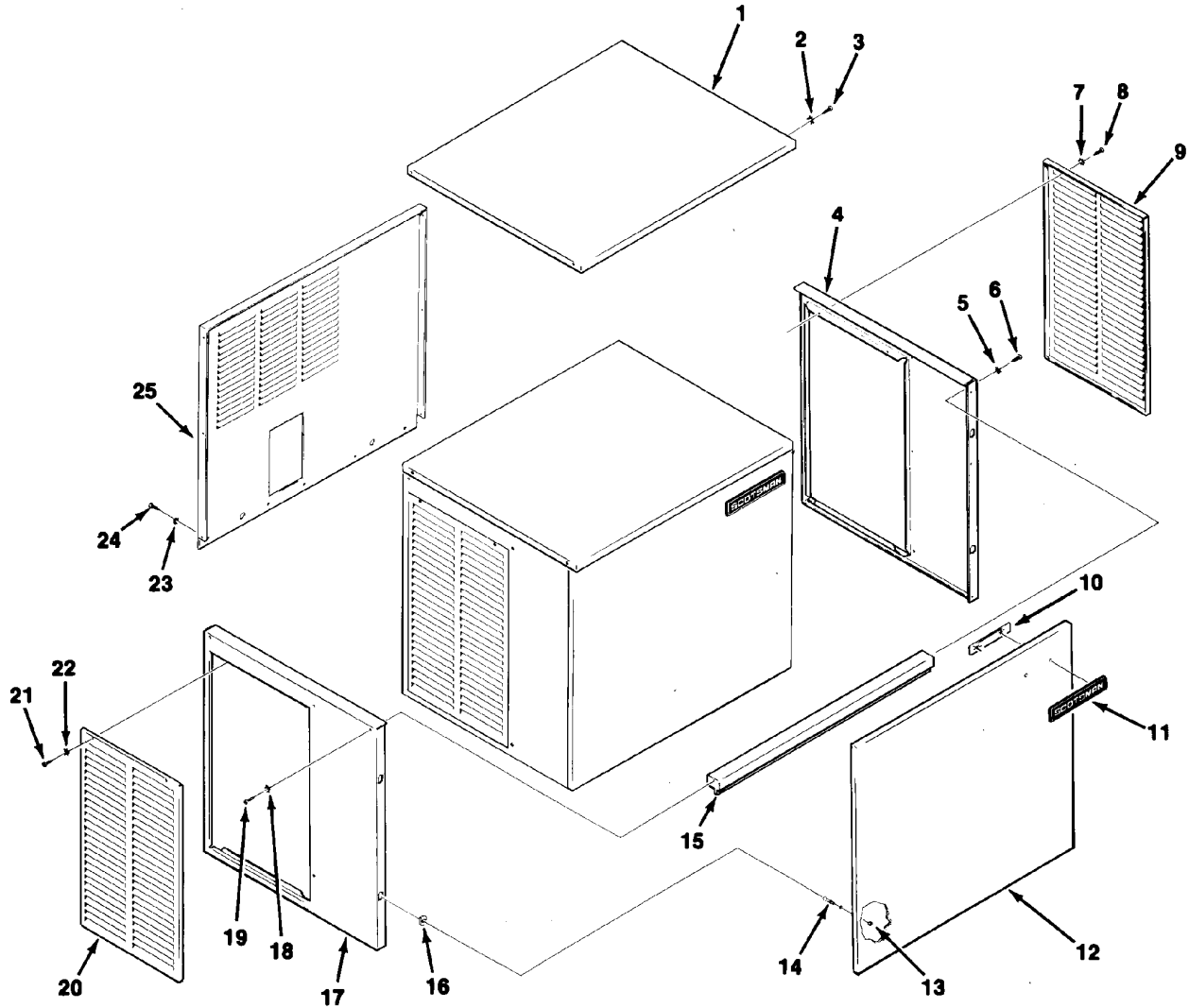

ITEM NUMBER	PART NUMBER	DESCRIPTION	ITEM NUMBER	PART NUMBER	DESCRIPTION
1	A32159-001	Top Panel, Painted	13	03-1406-04	Nut
	A32159-002	Top Panel, S. S.	14	15-0411-00	Strike
2	03-1417-03	Lockwasher	15	A32169-001	Front Support
3	03-1531-01	Screw	16	02-0836-00	Cabinet Catch
4	A32162-001	Right End Panel, Paint	17	A32163-001	Left End Panel, Paint
	A32162-002	Right End Panel, S.S.		A32163-002	Left End Panel, S.S.
5	03-1417-03	Lockwasher	18	03-1417-03	Lockwasher
6	03-1531-01	Screw	19	03-1531-01	Screw
7	03-1417-03	Lockwasher	20	A32161-001	Service Panel, sandalwood
8	03-1404-12	Screw		A33946-002	Service Panel, gray
9	A32161-001	Service Panel, Painted	21	03-1404-12	Screw
	A33946-002	Service Panel, gray	22	03-1412-03	Lockwasher
10	03-0271-00	Speed Nut	23	03-1417-03	Lockwasher
11	15-0711-01	Emblem	24	03-1531-01	Screw
12	A32160-001	Front Panel, Painted	25	A32201-001	Back Panel, painted
	A32160-002	Front Panel, S.S.		A32201-002	Back panel, stainless

CME500R SERVICE PARTS

CABINET INTERIOR

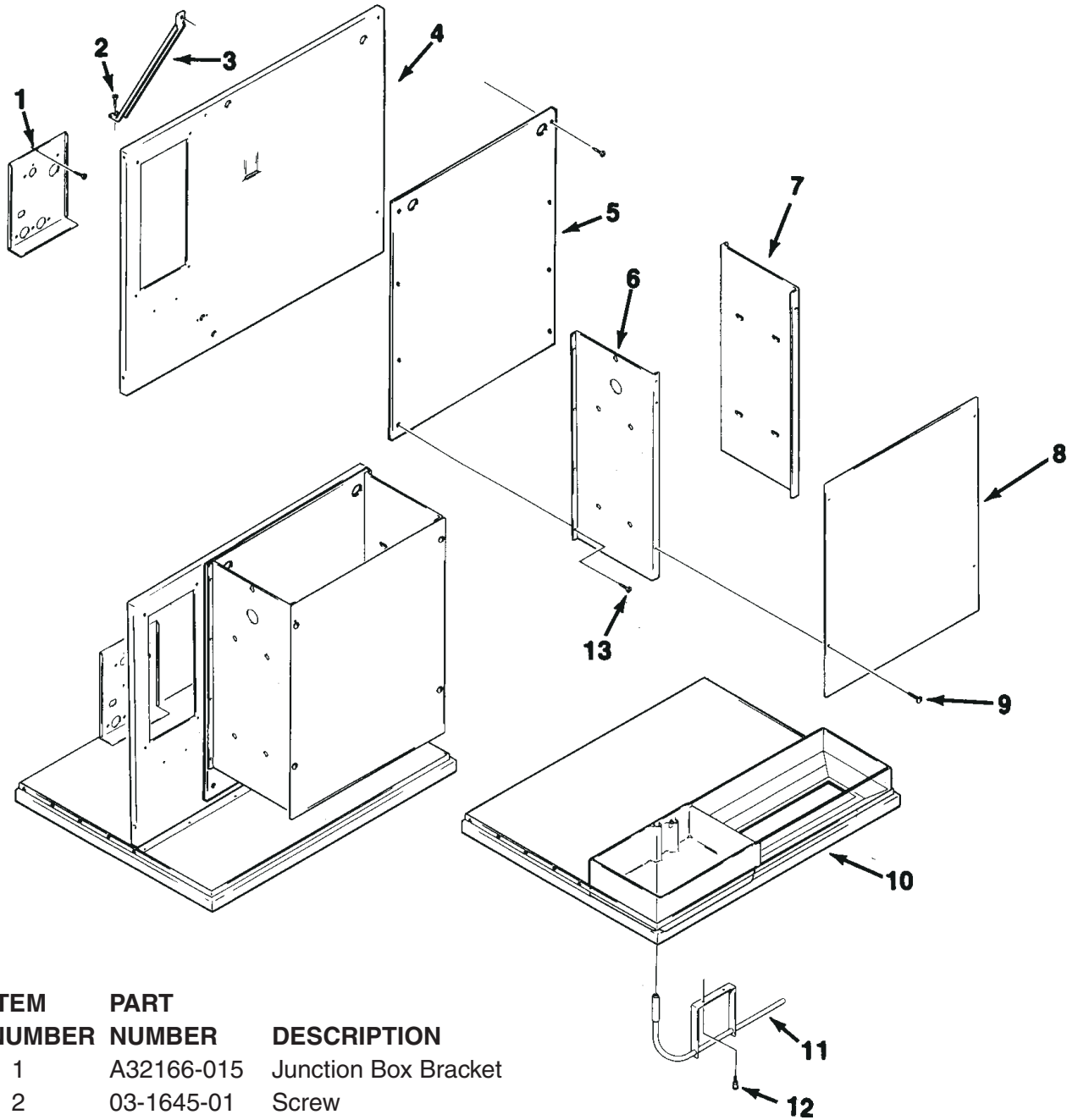

ITEM NUMBER	PART NUMBER	DESCRIPTION
1	A32166-015	Junction Box Bracket
2	03-1645-01	Screw
3	A32210-001	Support Brace
4	A32158-001	Retainer
5	02-2867-01	Splash Panel
6	A35671-001	Evaporator Bracket, Left
7	A32172-001	Evaporator Bracket, Right
8	02-3246-01	Evaporator Plate Cover
9	03-0727-09	Thumbscrew
10	A32153-001	Base
11	A32262-001	Bin Thermostat Bracket
12	03-0727-09	Thumbscrew
13	03-1531-02	Screw

CME500R SERVICE PARTS

REFRIGERATION

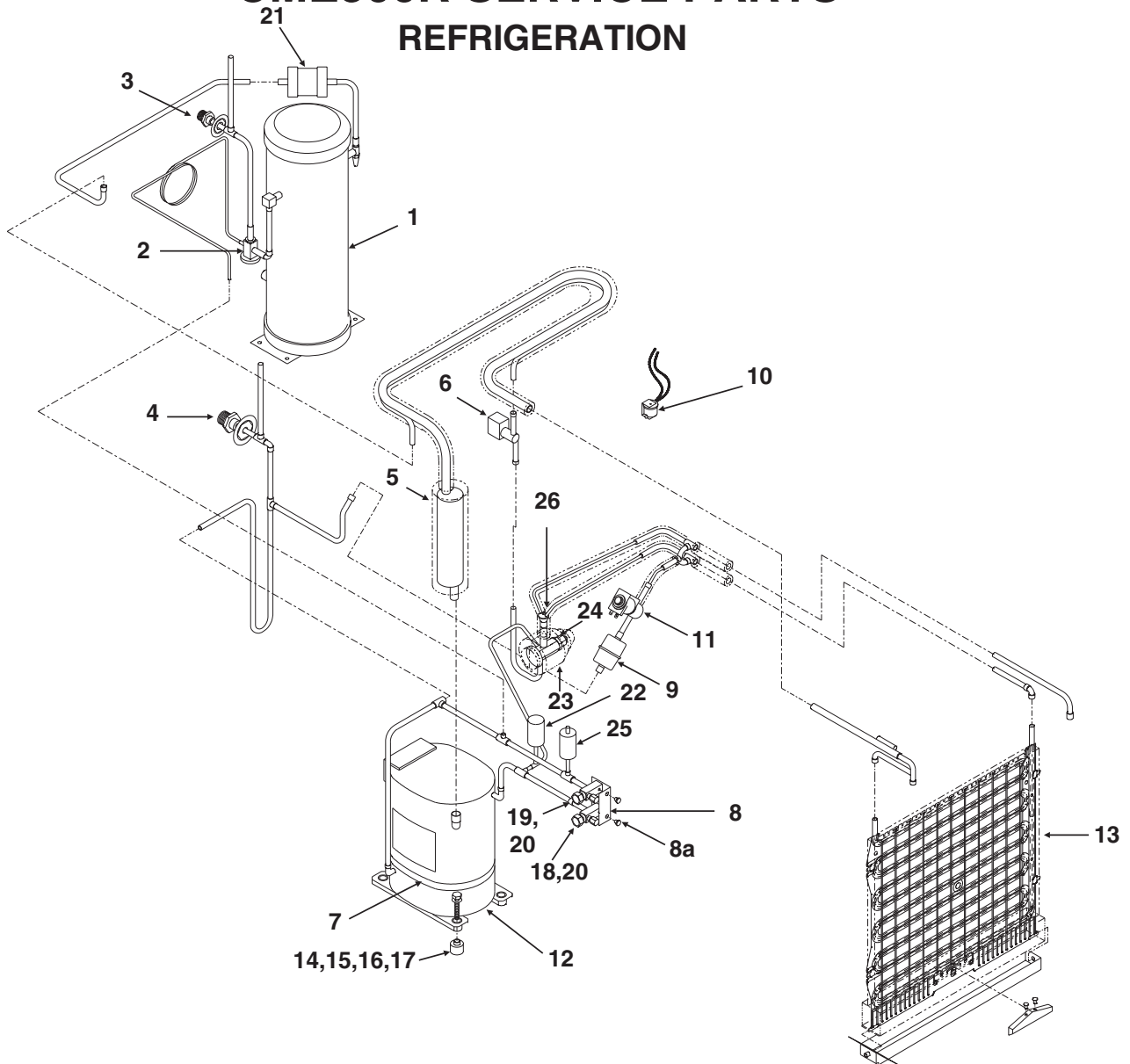

ITEM NUMBER	PART NUMBER	DESCRIPTION	ITEM NUMBER	PART NUMBER	DESCRIPTION
1	16-0761-01	Receiver	13	A30296-020	Evaporator
2	11-0422-24	Discharge press. control valve	14	18-2200-28	Grommet
3	16-0850-03	Quick connect fitting, 3/8"	15	18-2200-27	Sleeve
4	16-0850-01	Quick connect fitting, 1/2"	16	03-1407-07	Washer
5	A35812-001	Heat exchanger	17	03-1405-20	Screw
6	12-2135-21	Liquid line solenoid valve	18	16-0832-20	Lo side access valve (w/caps)
7	12-1868-01	Crankcase heater	19	16-0832-21	Hi side access valve (w/caps)
8	A35588-001	Bracket for valves	20	16-0832-02	Stem cap
8a	03-0571-02	Screw for valves		16-0832-03	Core cap
9	02-3231-01	Hot gas valve filter	21	02-3319-02	Drier
		(only used on -12L date code units)	22	11-0484-21	Pump down pressure switch
10	12-2300-03	Hi Temp Cut Out	23	A36067-001	TXV insulation
11	12-2417-21	115v Hot Gas Valve with coil	24	16-0867-21	TXV
12	18-8721-21	115v Compressor, includes drier	25	11-0485-21	Hi Pressure Cut Out Switch
	18-8711-50	Overload	26	16-0843-01	Distributor

CME500R SERVICE PARTS

WATER SYSTEM

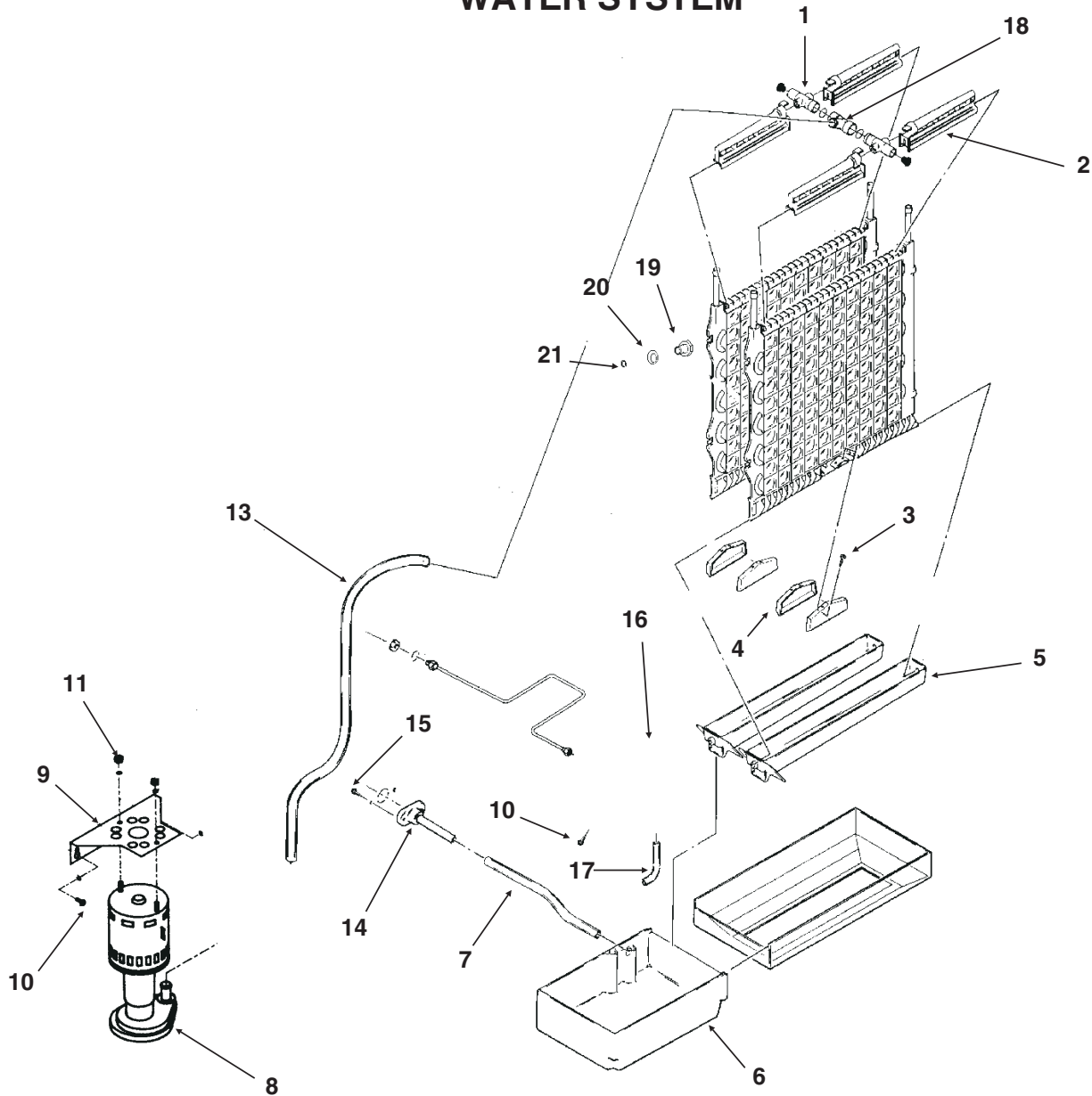

ITEM NUMBER	PART NUMBER	DESCRIPTION	ITEM NUMBER	PART NUMBER	DESCRIPTION
1	A29703-001	Manifold	13	13-0674-07	Pump hose, 33"
2	02-2527-01	Water distributor tube	14	A32282-003	Drain assembly
3	03-1404-10	Screw	15	03-1645-01	Screw
4	02-2878-01	End cover	16	12-2446-23	115v Inlet water valve
5	02-2868-01	Drain trough	17	A30918-001	Water inlet tube
6	02-2869-01	Reservoir	18	02-2519-01	Tee
7	13-0674-07	Drain hose, 8"	19	02-2642-01	Plate mount
8	12-2265-21	115v Water pump	20	03-1408-34	Washer
9	A35554-015	Pump bracket	21	03-1394-03	Pal nut
10	03-1531-01	Screw			
11	03-1406-05	Nut			
12	03-1417-06	Lockwasher			

CME500R SERVICE PARTS CONTROL BOX

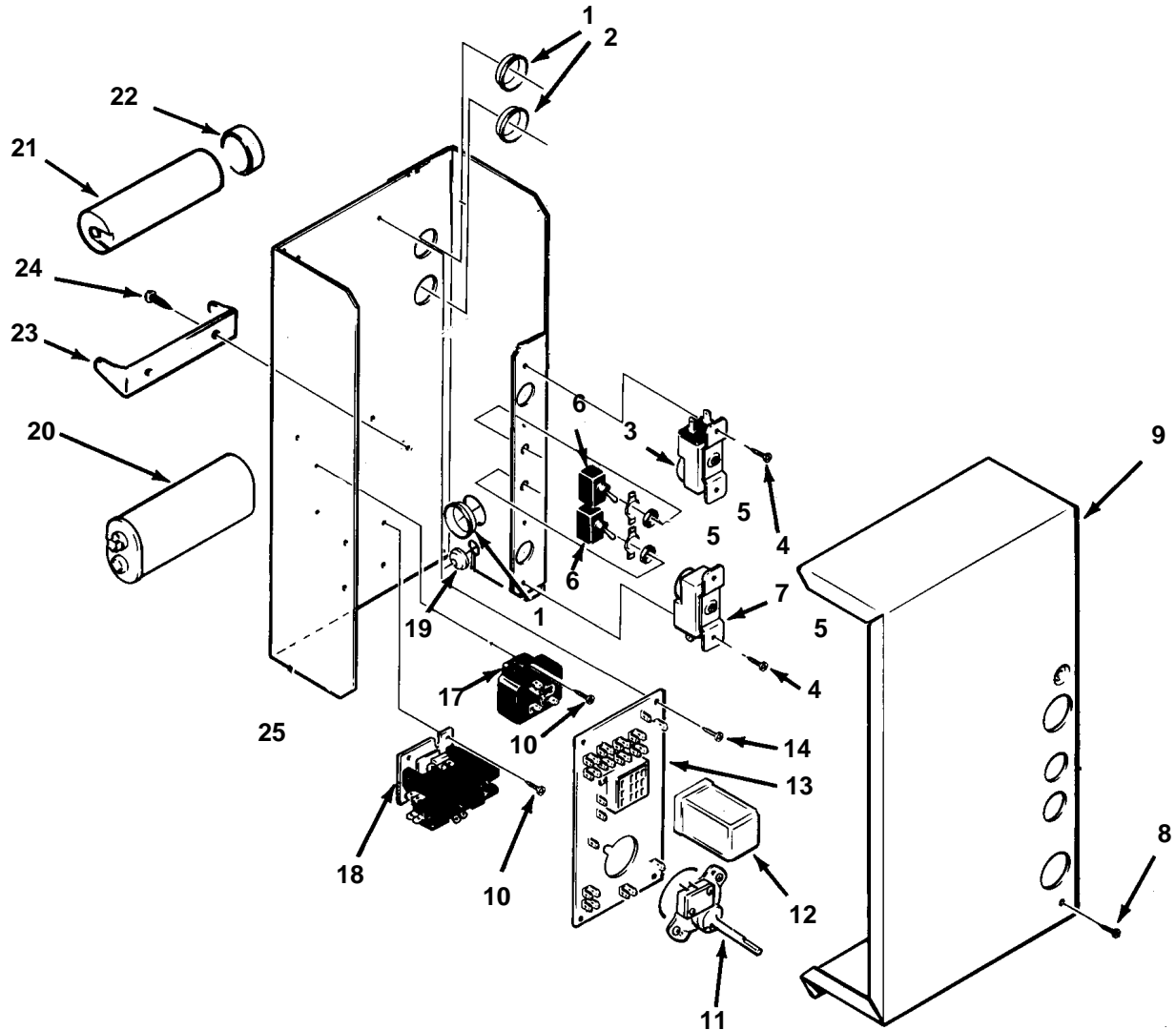

ITEM NUMBER	PART NUMBER	DESCRIPTION	ITEM NUMBER	PART NUMBER	DESCRIPTION
1	12-1213-17	Snap bushing	16	03-1417-03	Lockwasher
2	12-1213-10	Snap bushing	17	18-1903-50	115v Potential relay
3	11-0437-21	Cube size thermostat	18	12-2048-01	115v Contactor
4	03-1403-17	Screw	19	12-1213-04	Snap bushing
5	03-1417-27	Lockwasher	20	18-1902-45	115v Run capacitor
6	12-0426-01	Toggle switch		13-0666-00	Cap for run capacitor
7	11-0427-22	Bin thermostat		A32872-001	Clamp for run capacitor
8	03-1531-01	Screw	21	18-1901-03	115v Start capacitor
9	A32168-001	Control Box Cover	22	18-2200-38	Cap for start capacitor
10	03-1638-03	Screw	23	18-2200-39	Bracket for start capacitor
11	12-2317-21	115v Timer & Switch	24	03-1418-06	Screw
12	12-1879-02	Relay, 115 V	25	03-1406-06	#10 Hex nut
13	12-1912-01	Circuit Board			
14	03-1403-02	Screw			
15	03-1403-05	Screw			

CME500R SERVICE PARTS

REMOTE CONDENSER

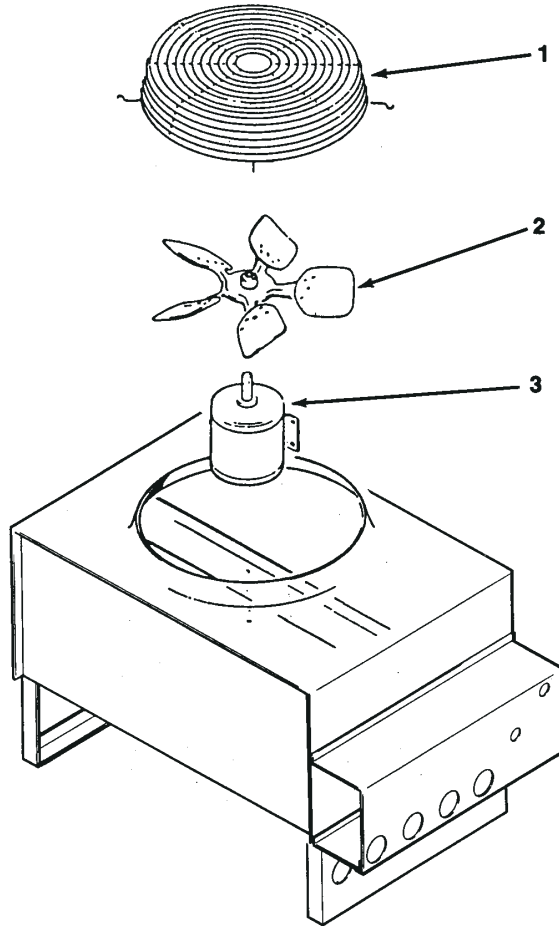

RCE501-1

ITEM NUMBER	PART NUMBER	DESCRIPTION
1	02-2618-01	Fan Guard
2	18-6304-01	Fan Blade
3	18-6305-01	Fan Motor

For Pre Charged Line Set

4	16-1057-01	Female coupling (3/8")
5	16-1057-02	Female coupling (1/2")

ERC101 - production began Jan. 1996

1	02-3575-01	Fan guard
2	18-8800-01	Fan blade
3	18-8796-01	Fan motor

CME500R SERVICE PARTS

115v, 60 Hz WIRING DIAGRAM

A35985-001

THIS UNIT MUST BE GROUNDED

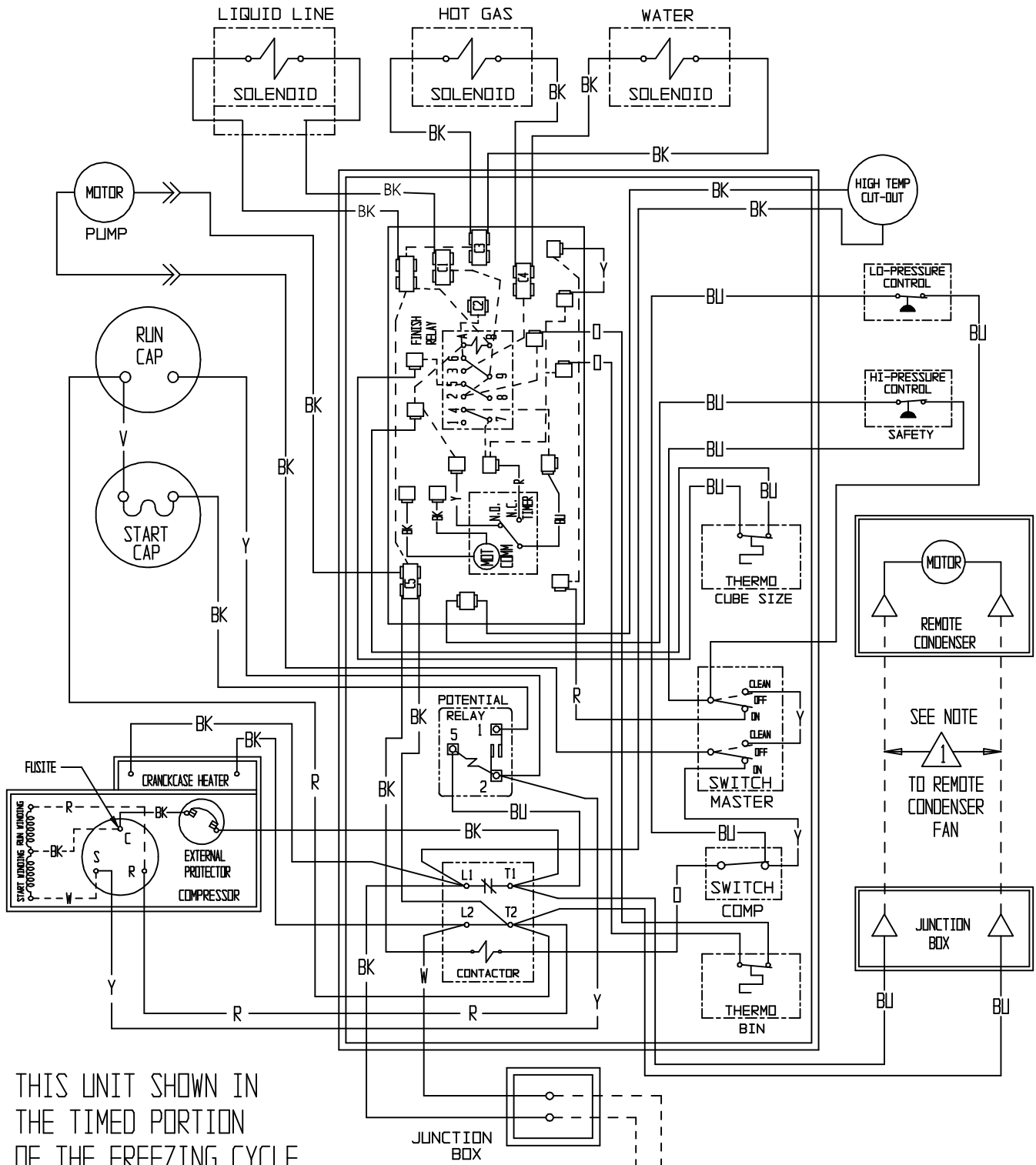

THIS UNIT SHOWN IN THE TIMED PORTION OF THE FREEZING CYCLE

USE COPPER CONDUCTORS ONLY

POWER SUPPLY:
SEE NAMEPLATE FOR PROPER VOLTAGE
REQUIREMENTS AND MAXIMUM FUSE SIZE

CME500R SERVICE PARTS 115v, 60 Hz SCHEMATIC DIAGRAM

CAUTION:
MORE THAN ONE DISCONNECT
MEANS MAY BE REQUIRED
TO DISCONNECT ALL POWER
TO THIS UNIT

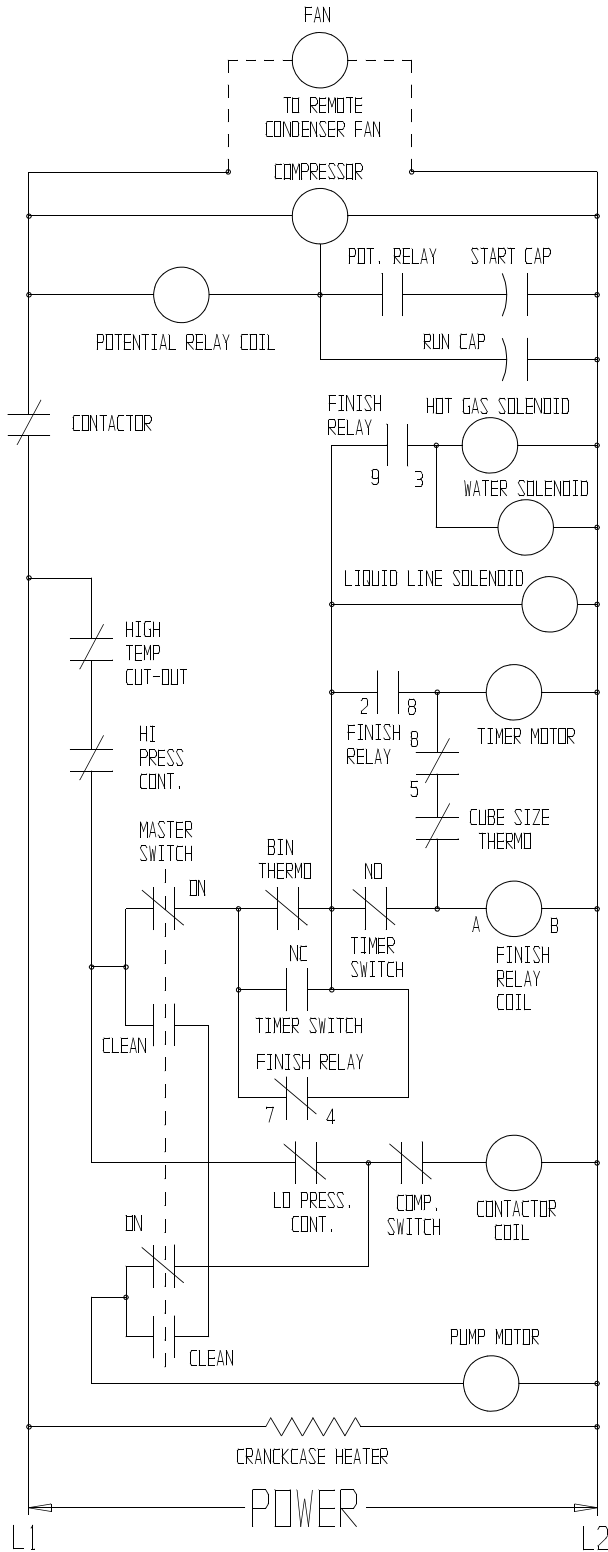

CME500R SERVICE PARTS