

AC25 PARTS ILLUSTRATIONS AND PARTS LISTS

THIS SECTION CONTAINS THE PARTS ILLUSTRATIONS AND PARTS LISTS FOR THE AC25.

A NO NUMBER DESIGNATION, WHEN USED IN THE NUMBER COLUMN, INDICATES THE UNIT IS NOT AVAILABLE FROM SCOTSMAN AS AN ASSEMBLY. THIS DESIGNATION IS USED ONLY FOR CLARITY OF DIVISION IN MAKING THE LIST.

WHEN ORDERING PARTS OF ASSEMBLIES, TO AVOID COSTLY DELAYS AND ERRORS IN SHIPMENT, GIVE THE PART NUMBER, THE COMPLETE DESCRIPTION SHOWN IN THE LIST AND THE QUANTITY OF EACH PART OR ASSEMBLY REQUIRED.

TABLE OF CONTENTS

MAJOR ASSEMBLIES	PAGES 2-3
PANEL PARTS	PAGE 4
COMPRESSOR.....	PAGE 5
FREEZING CHAMBER	PAGE 6
CONTROL BOX.....	PAGE 7
WIRING DIAGRAM	
AIR COOLED.....	PAGES 8-9
WATER COOLED.....	PAGES 10-11

17-1470-20
JUNE 1987

AC25 PARTS LIST

MAJOR ASSEMBLIES

ITEM NUMBER	PART NUMBER	DESCRIPTION	ITEM NUMBER	PART NUMBER	DESCRIPTION
1	No Number	Fan Motor Assembly			
1a	18-3715-01	Fan Blade	15	A27064-001	Cube Chute, Left-med. Cube
1b	02-2378-01	Motor Bracket		A27060-001	Cube Chute, Right-med.Cube
1c	12-2050-01	Fan Motor		A26916-001	Cube Chute, Left-small Cube
	03-1404-09	Mounting Screw		A26923-001	Cube Chute, Right-sm. Cube
2	A26949-001	Fan Shroud	16	02-2331-01	Water Reservoir Only
3	18-3716-01	Air Cooled Condenser		03-1404-12	Mounting Screw
	03-0571-00	Shroud To Condenser Screw	17	02-0831-00	Drier
4	A26994-001	Defrost Tube	18	A09386-000	Drier Brace
5	A27052-020	Evaporator, Medium Cubes		03-1404-09	Mounting Screw
	A26946-020	Evaporator, Small Cubes	19	A26955-001	Control Box Cover
6	A28797-020	Heat Exchanger	20	No Number	Control Box Complete
7	12-2008-01	Hot Gas Valve Coil		03-1404-09	Mounting Screw,cov. to Box
	12-2007-01	Hot Gas Valve Body	21	no number	Front Mounting Brakcet
8	A26956-001	Bracket	22	no number	Back Mounting Bracket
	03-1404-09	Mounting Screw		03-1405-03	Mounting Screw
	03-1403-14	Mounting Screw	23	12-1213-10	Snap Bushing,(11/16")
9	A27735-001	Agitator Motor	24	12-1213-06	Snap Bushing, (1/2)
	12-0675-25	Fan Blade	25	05-0501-01	Preformed Drain Hose
	03-1403-22	Motor Mounting Screw		02-1338-00	Hose Clamp For The Above
10	A28961-001	Water Pump	26	18-4500-01	Compressor
	03-0571-00	Mounting Screw		18-2200-27	Mounting Sleeve
	A27068-001	Preformed Tube		18-2200-28	Grommet
	13-0674-07	Tygon Tube (6-3/4")		03-1407-07	Washer
	02-1358-01	1 Inch Hose Clamp		03-1405-20	Mounting Bolt
	02-1530-01	15/16" Hose Clamp	27	A26948-002	Bin/ Base Assembly, S/S
11	A26918-001	Pump Bracket		A26948-003	Bin / Base Assembly Painted
	03-1404-09	Mounting Screw	28	No Number	Water Regulator Assembly
12	No Number	Water Inlet Assembly		03-0571-00	Bracket Mounting Screw
	03-0571-00	Mounting Screw		A25805-001	Mounting Bracket
12a	12-1900-10	Inlet Water Valve		11-0198-02	Water Regulating Valve
	A25969-001	Water Inlet Fitting	29	18-3707-01	Water Cooled Condenser
12b	A25805-001	Mounting Bracket	30	03-0774-08	Spring Pin
	03-1394-01	Pal Nut	31	A27752-001	Drive Tube
13	03-0674-04	Tygon Tube, (3/4") Order By The Foot			
	03-0535-01	Hose Clamp			
14	02-2353-01	Cube Deflector			
	03-1404-12	Mounting Screw			

AC25 PARTS ILLUSTRATION AND PARTS LIST

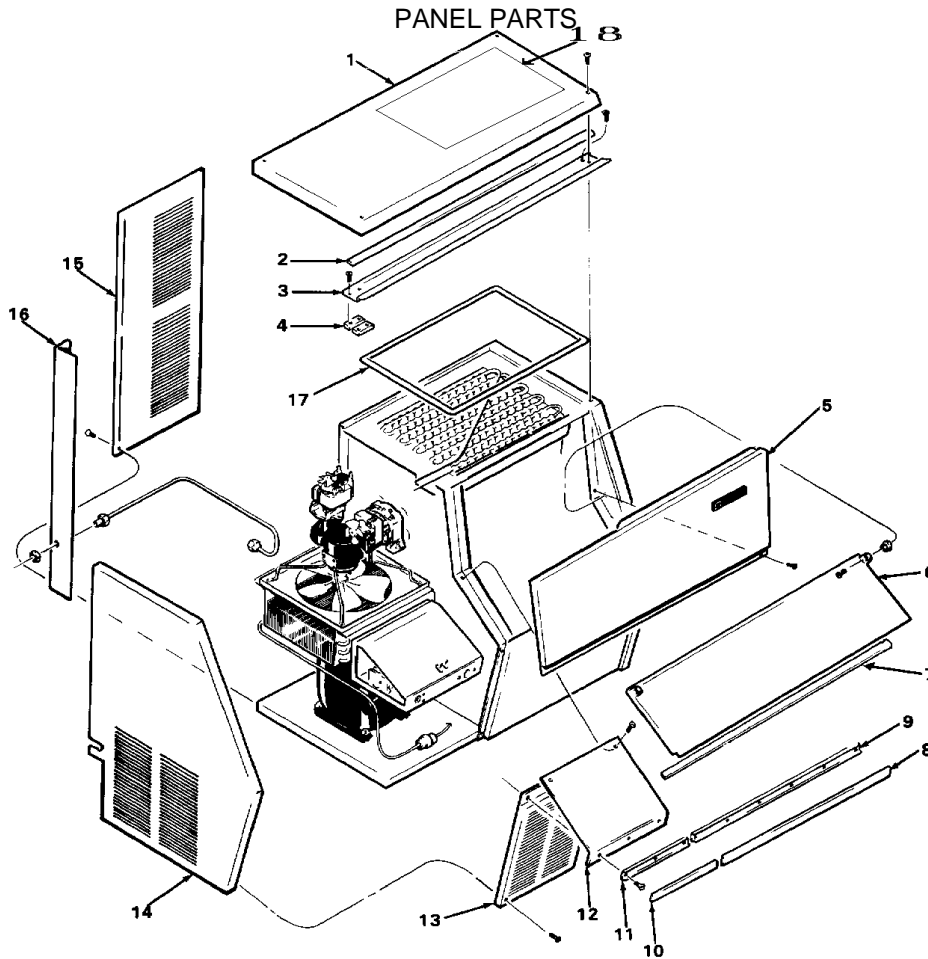

ITEM NUMBER	PAF NUMBER	DESCRIPTION	NUMBER	NUMBER	DESCRIPTION
1	A26931-005	Top Panel, sandalwood	10	15-0618-01	Moulding Cover 11.75
	A26931-015	Top panel, gray	11	15-0616-01	Left Track Section
	A26931-004	Top Panel, Stainless		03-1404-04	Mounting Screw
	03-1419-09	Mounting Screw	12	A26921-005	Baffle, sandalwood
2	15-0595-00	Gasket (34") Order per foot		A26921-015	Baffle, gray
	A28213-001	Top Brace		A26921-004	Baffle, S. S.
3	no number	Spacer		03-1419-10	Mounting Screw
	03-1404-12	Mounting Screw	13	A26928-005	Lower L. Fr. Pnl. sandalwood
	03-1404-10	Mounting Screw		A26928-015	Lower L. F. panel, gray
	5	A26935-004	Upper Front Pnl. sandalwood		A26928-004
A26935-015		Upper front panel, gray		03-1419-09	Mounting Screw
A26935-003		Upper Front Pnl. S.s.	14	A27520-004	Left Side Panel, sandalwood
03-1404-10		Mounting Screw		A27520-015	Left side panel, gray
6	02-2332-03	Door, Brown Plastic		A27520-002	Left Side Panel, S.s.
	02-2332-02	Door, Gray Plastic		03-1404-10	Mounting Screw s.s.
	02-2332-04	Door, Gray for enamel	15	A26945-001	Rear Panel
	02-2380-01	Hinge Bushing		03-1404-09	Mounting Screw
7	03-1405-07	Hinge Screw	16	A27066-003	Left Rear corner, sandalwood
	13-0595-00	Gasket (33") Order per foot		A27066-015	Left rear corner, gray
8	15-0619-01	Moulding Cover 22.44"		A27066-002	Left Rear Corner, S.s.
9	15-0617-01	Track Section 21"	17	13-0595-00	Gasket, (67") Order per foot
	03-1404-07	Mounting Screw		18	A26917-001

AC25 PARTS ILLUSTRATION AND PARTS LIST COMPRESSOR

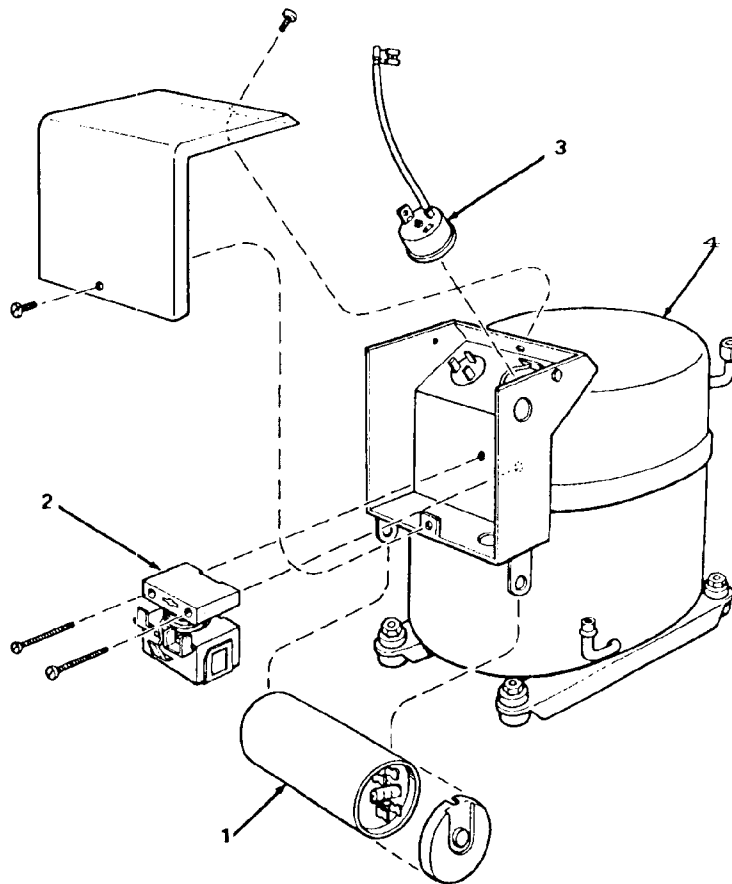

ITEM NUMBER	PART NUMBER	DESCRIPTION
1	18-1901-33	START CAPACITOR WITH CAP
2	18-2200-26	RELAY
3	18-2200-25	OVERLOAD
4	18-4500-01	COMPRESSOR INCLUDES ITEMS 1,2,AND 3.

AC25 PARTS ILLUSTRATION AND PARTS LIST FREEZING CHAMBER

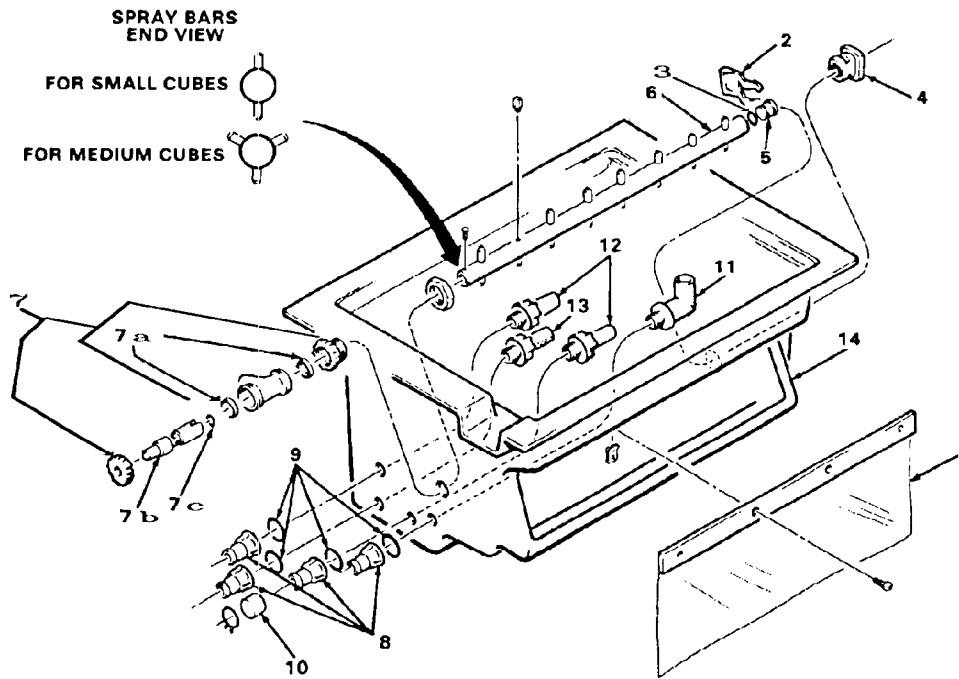

ITEM NUMBER	PART NUMBER	DESCRIPTION	ITEM NUMBER	PART NUMBER	DESCRIPTION
1	02-2327-01	Curtain	7b	02-2427-01	Drive Journal
	03-1403-10	Mounting Screw	7c	13-0617-30	O-ring
	03-1422-04	Speed Nut	8	02-2606-01	Female Tube
2	A26901-001	Retaining Clip	9	13-0617-02	O-ring
3	13-0617-42	O-ring	10	13-0796-01	Rubber Cap
4	02-2419-01	Spray Bar End		02-1530-01	Hose Clamp
5	02-2420-01	Spray Bar Plug	11	02-2125-01	Stand Pipe
6	A27756-001	Spray Bar, small Cube	12	02-2080-01	Male Tube
	A27755-001	Spray Bar, Med. Cube	13	02-2082-01	Pump Pick Up Tube
	02-1803-01	Jet, med. Cube (24) small Cube (2)	14	02-2331-01	Freezing Chamber
	02-2663-01	Jet, Small Cube (22)			
7	02-2418-01	Drive Housing, Includes 7a, but not 7b or 7c			
7a	13--0819-01	U-cup Seal++			

AC25 PARTS ILLUSTRATION AND PARTS LIST

CONTROL BOX

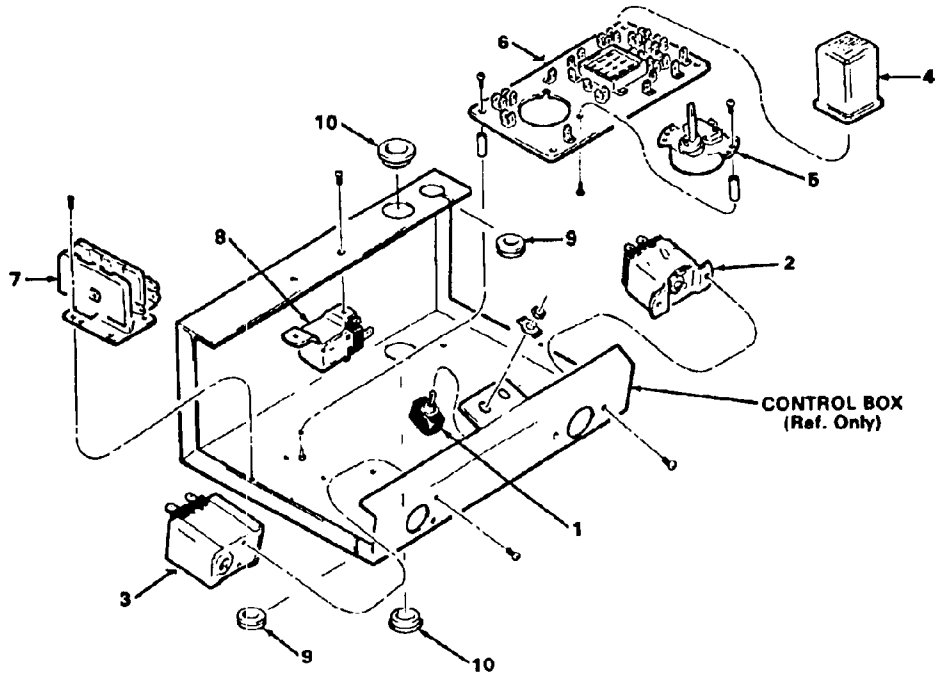

ITEM NUMBER	PART NUMBER	DESCRIPTION	ITEM NUMBER	PART NUMBER	DESCRIPTION
1	12-0426-01	Toggle Switch	6	12-1912-01	P.C. Board
2	11-0345-23	Cube Size Control		02-2242-02	Stand Off (5/8")
	03-1403-14	Mounting Screw		03-1403-02	Mounting Screw
3	11-0389-22	Fan Control, Air Cooled Models	7	12-2048-01	Contactor
	11-0388-23	High Pressure Control. Water Cooled	8	03-1403-02	Mounting Screw
	03-1403-02	Mounting Screw	8	11-0353-22	Bin Thermostat
4	12-1879-02	Relay	9	13-0115-00	Grommet
5	12-1980-01	Timer With Switch	10	12-1213-10	Bushing
	02-2242-01	Stand Off (7/8")			
	03-1403-02	Mounting Screw			

AC25 COMPONENT LAY OUT DIAGRAM

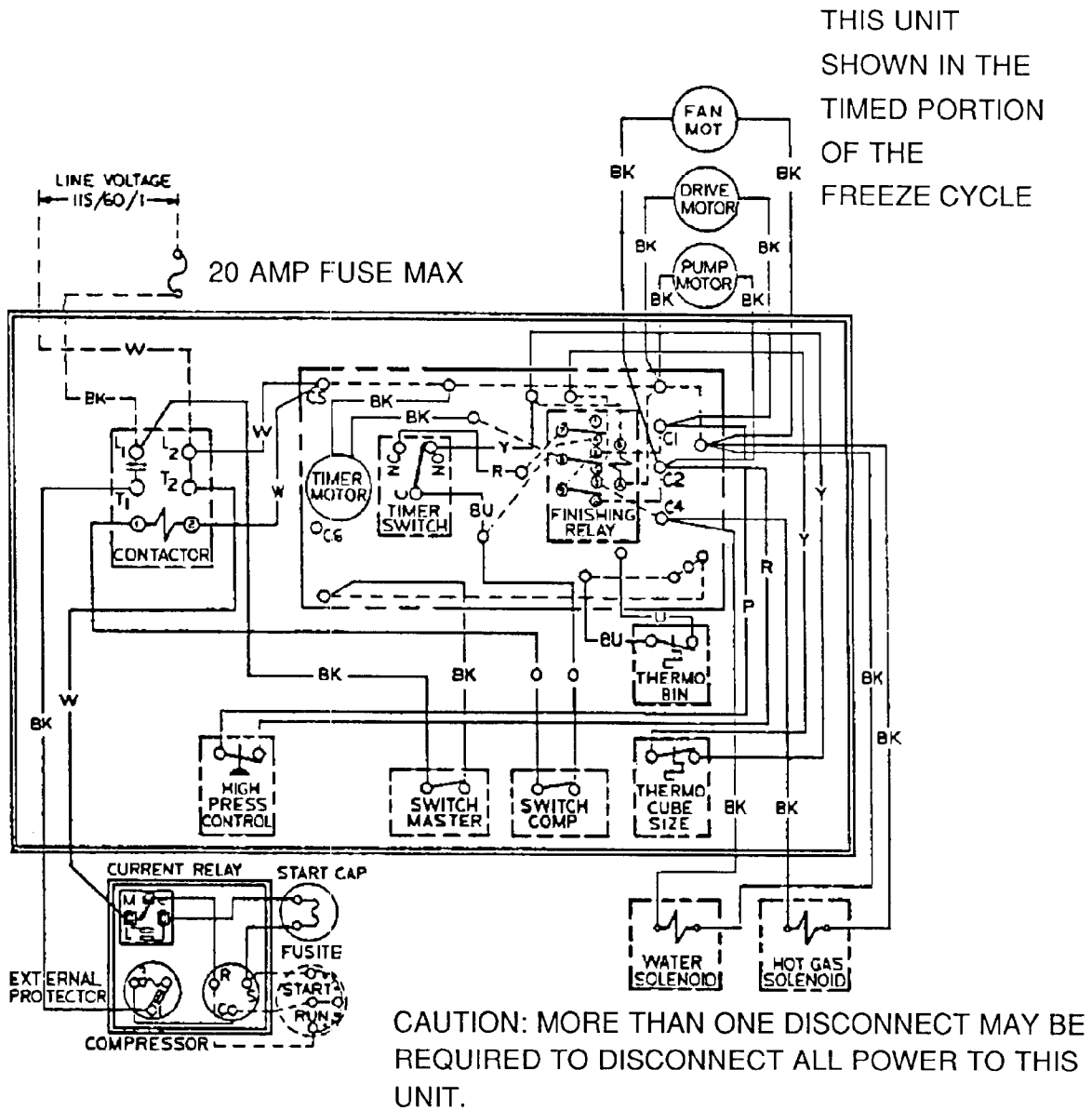

THIS UNIT MUST BE GROUNDED

AC25 AIR COOLED, 115V/60/1

AC25 SCHEMATIC DIAGRAM

AIR COOLED

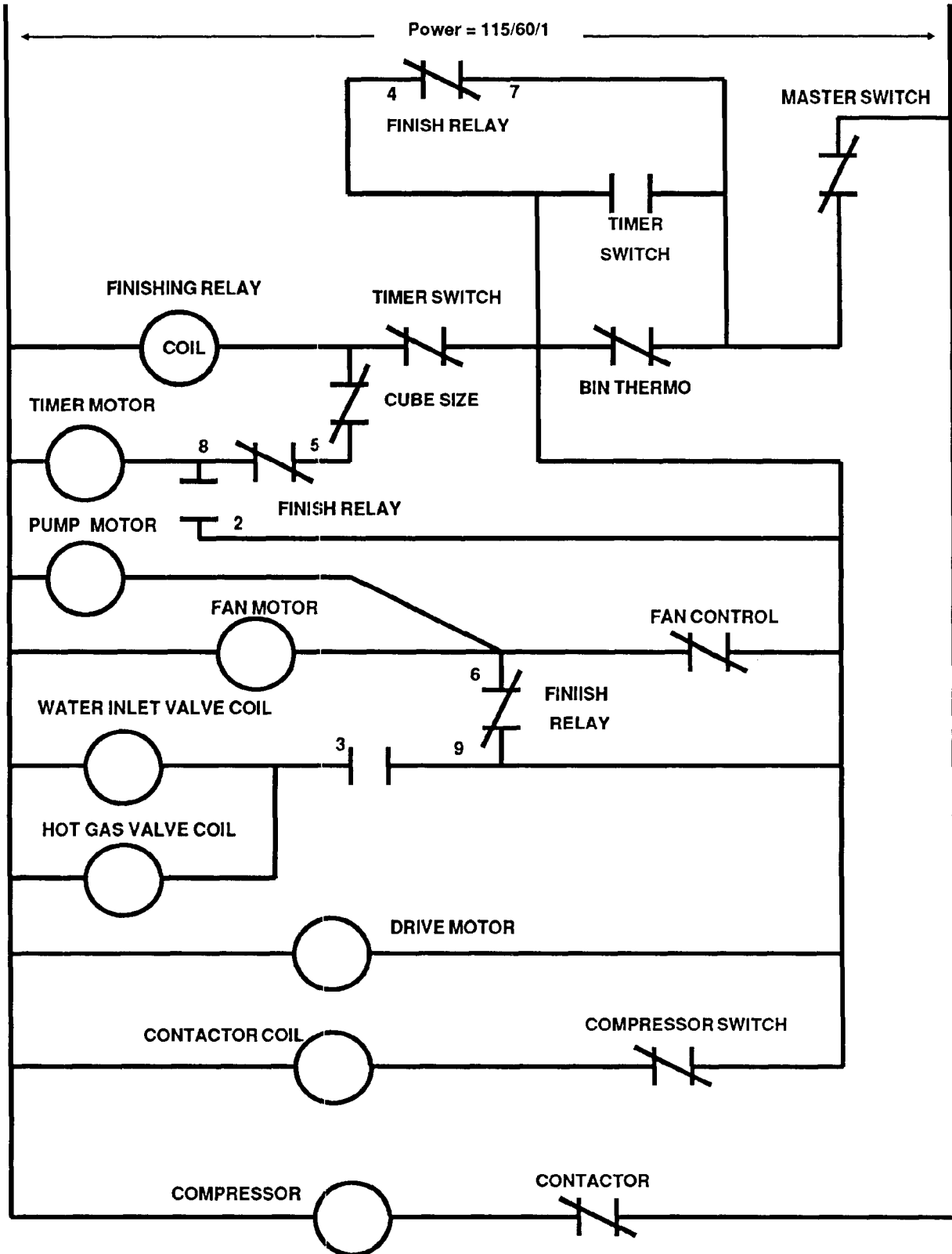

AC25 COMPONENT LAY-OUT DIAGRAM

USE COPPER CONDUCTORS ONLY

THIS UNIT SHOWN IN THE TIMED FREEZE CYCLE

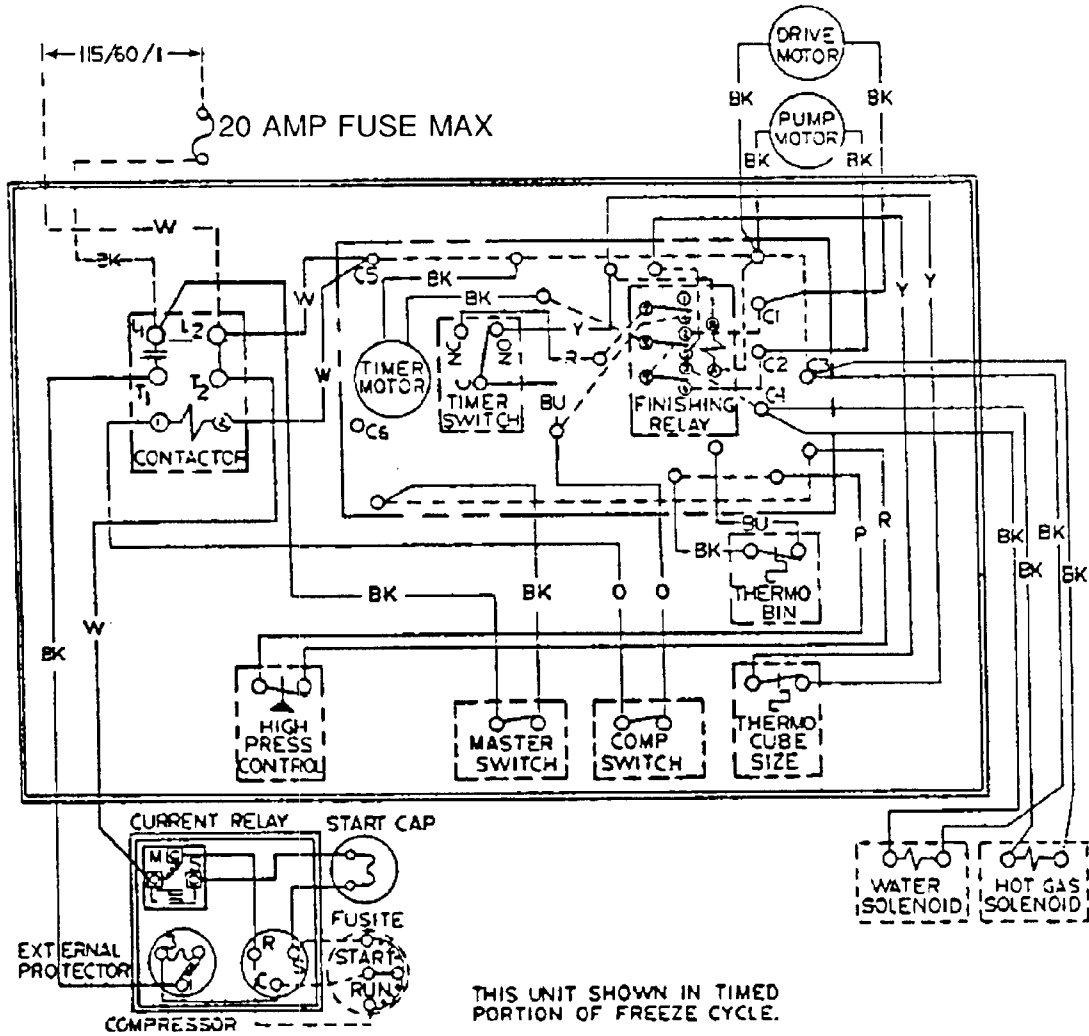

CAUTION: MORE THAN ONE DISCONNECT MAY BE REQUIRED TO DISCONNECT ALL POWER TO THIS UNIT.

THIS UNIT MUST BE GROUNDED

AC25 WATER COOLED, 115V/60/1

AC25 SCHEMATIC DIAGRAM WATER COOLED

