

IF IN DOUBT ASK!!

DO NOT SCALE !!

First Angle Projection

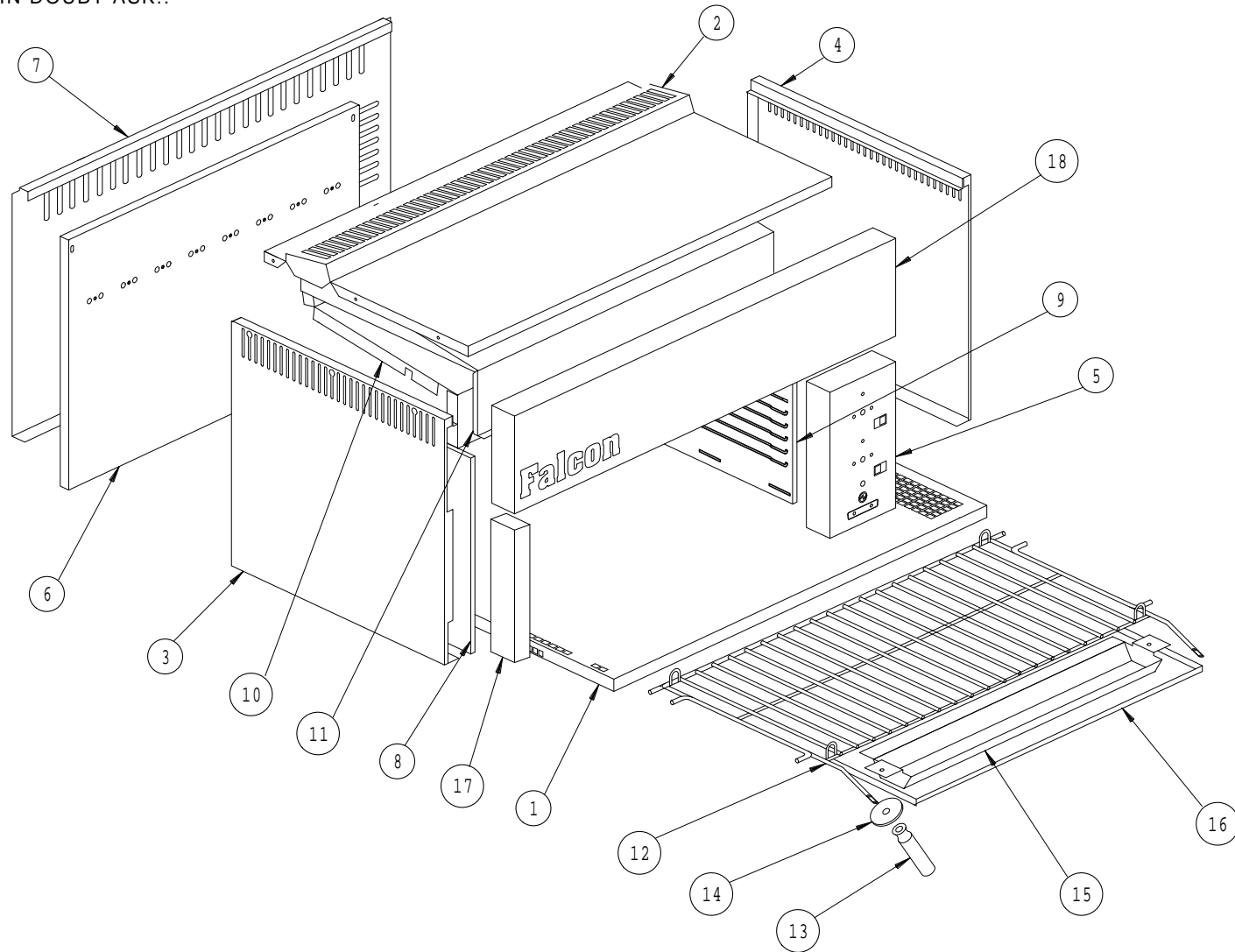
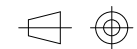

ITEM	DESCRIPTION	SPARES No
1	Base	531620070
2	Outer Top	531620050
3	Outer Side LH	535910008
4	Outer Side RH	531610250
5	Control Panel	731590002
6	Inner Back	731590004
7	Outer Back	731590005
8	Inner Side LH	531610390
9	Inner Side RH	531610350
10	Inner Top	531620090
11	Cooling Plate	531620080
12	Wire Grid	731550051
13	Handle for Wire Grid	531532190
14	Disc for Wire Grid	531532200
15	Drip Trough	731590000
16	Drip Tray	731590001
17	Front Trim	535910006
18	Front Facia	535920040

E2522 GRILL FITMENTS

All Dimensions in millimetres, Tolerance- Linear $\pm 0.5\text{mm}$ Angular $\pm 0.5^\circ$ (or as stated)

A	949	ISSUED FOR PRODUCTION		S. MOONEY	8/8/03
Issue	Mod No.	Alteration	Zone	Drawn by	Date



Drawn	S. MOONEY	Product	E2522 GRILL	
Date	22/7/03	Title	SPARES DIAGRAM-FITMENTS	
Scale				
Matl.		Drawing Number	AD41571	Issue
No. off				A
Bin No.	RZZ370			

© No reproduction or publication of this drawing may be made and no article may be manufactured or assembled in accordance with this drawing without prior written consent. This prohibition is a term of any contract relating to this drawing. Rights reserved under the Copyright Act 1956 as amended by the Design Copyright Act 1968.

This part is common to the following units

UNCONTROLLED

IF IN DOUBT ASK!!

DO NOT SCALE !!
First Angle Projection

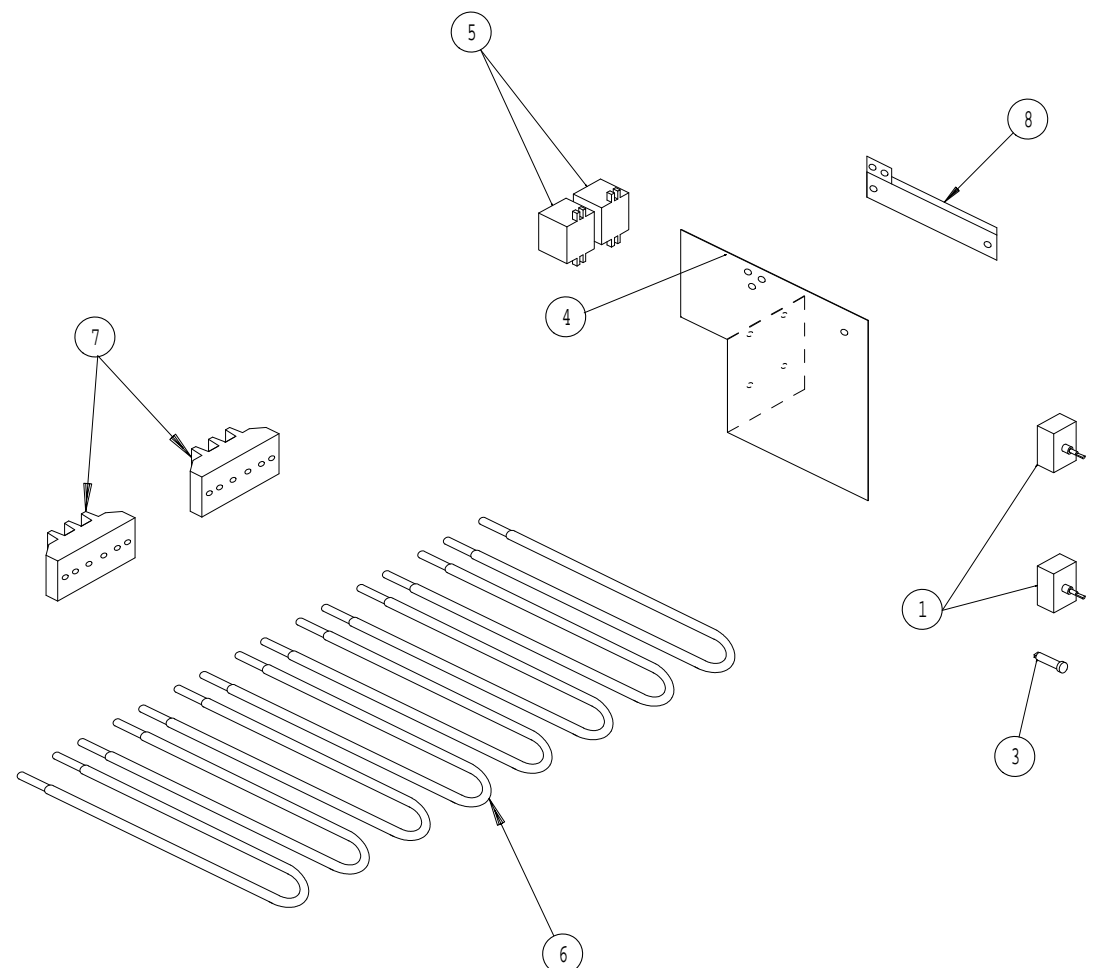
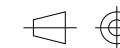

ITEM	DESCRIPTION	SPARES No
1	Energy Regulator	737630011
2	Control Knob	731570001
3	Neon Indicator	730400180
4	Relay Bracket	731580009
5	Relay	731580008
6	Element	731540400
7	Terminal Block	731580006
8	MainsTerminal Block	731580010

E2522 GRILL CONTROLS

All Dimensions in millimetres, Tolerance- Linear $\pm 0.5\text{mm}$ Angular $\pm 0.5^\circ$ (or as stated)

A	949	ISSUED FOR PRODUCTION		S.MOONEY	8/8/03
Issue	Mod No.	Alteration	Zone	Drawn by	Date



This part is common to the following units

© No reproduction or publication of this drawing may be made and no article may be manufactured or assembled in accordance with this drawing without prior written consent. This prohibition is a term of any contract relating to this drawing. Rights reserved under the Copyright Act 1956 as amended by the Design Copyright Act 1968.

Drawn S.MOONEY	Product E2522 GRILL	
Date 22/7/03	Title SPARES DIAGRAM-CONTROLS	
Scale		
Matl.	Drawing Number	Issue
No. off	AD41572	A
Bin No. RZZ370	Kraus No.	

UNCONTROLLED