

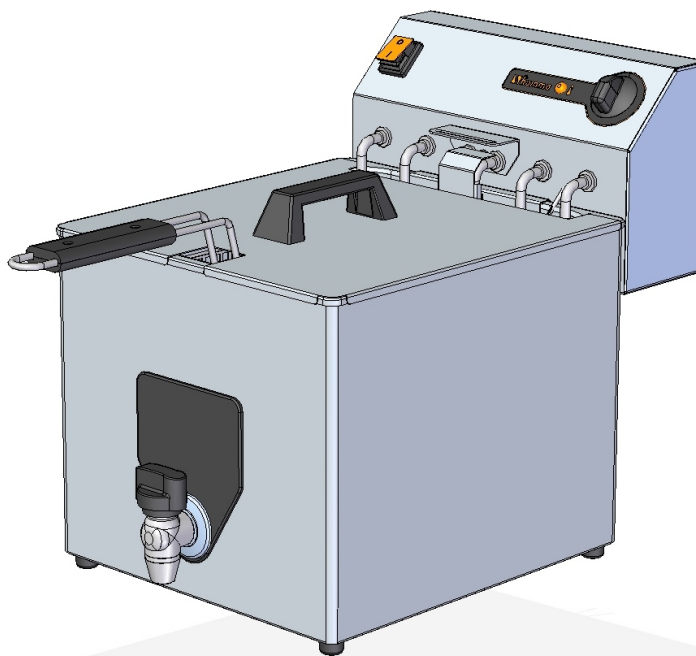

FRITADEIRA FF15TR FRYER FF15TR



FRITADEIRA FF15TR FIAMMA - 2.0.091.0000 FRYER FF15TR FIAMMA

POTÊNCIA 9000 W
POWER

TENSÃO DE ALIMENTAÇÃO 400-3N V(~)-50Hz
POWER SUPPLY

TERMOSTATO REGULÁVEL 90-180 °C
ADJUSTABLE THERMOSTAT

PRODUTIVIDADE 25 kg/h
PRODUCTIVITY

PESO LIQUIDO 11.5 kg
NET WEIGHT

PESO BRUTO 13 kg
GROSS WEIGHT

DIMENSÕES (LxPxH) 322x520x415 mm
DIMENSIONS (LxPxH)

DIMENSÕES DA EMBALAGEM (LxPxH) .. 370x545x445 mm
PACKAGE DIMENSIONS

DIMENSÕES DO CESTO (LxPxH) 285x285x118 mm
BASKET DIMENSIONS

CAPACIDADE DE ÓLEO 13 L
OIL CAPACITY

FRITADEIRA FF15TR

FRYER FF15TR

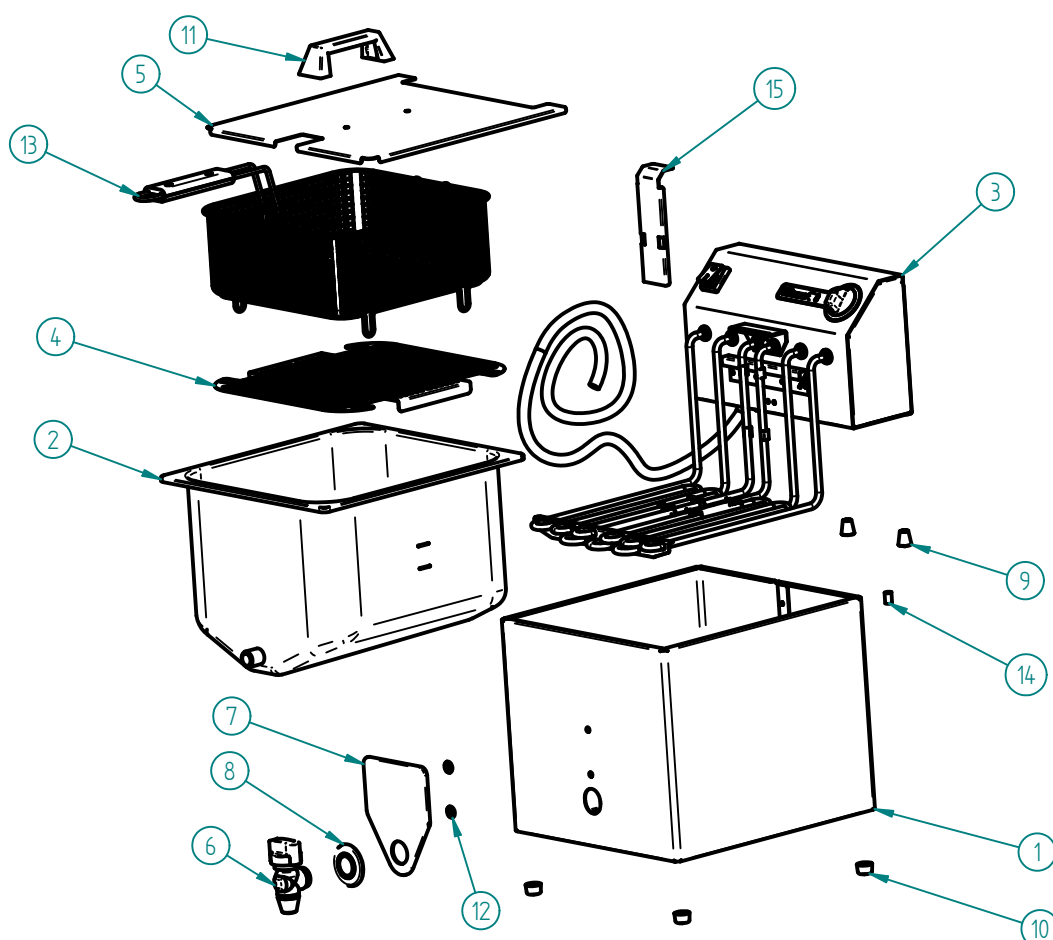

LISTA DE COMPONENTES E ACESSÓRIOS

Spare parts list

ITEM Nº	CÓDIGO	DESIGNAÇÃO	DESIGNATION	QUANT.
1	7.0.091.1005	BLINDAGEM CONJUNTO FF15TR REBIT.	SHIELDS ASS. FF15 TR REBIT.	1
2	4.0.091.0029	CUBA NIQUELADA FF15TR	TANK FF15	1
3	7.0.091.0000	CABEÇOTE MONTADO FF15TR	ELECTRIC UNIT ASS. FF15 TR	1
4	7.0.091.0070	GRELHA PROTECÇÃO RESIST. FF15TR	HEATING ELEMENT PROTECTION GRID	1
5	7.0.091.0060	TAMPA CUBA FF15TR	TANK COVER FF15 TR	1
6	4.0.087.0030	TORNEIRA G1/2	TAP G1/2F	1
7	4.0.087.0034	PROTECÇÃO TERMICA TORNEIRA FF	THERMIC TAP PROTECTION	1
8	4.0.087.0032	ESPELHO CROMADO 3/4"	CHOMED MIRROR 3/4"	1
9	4.0.085.0027	MANIPULO FRITADEIRAS (M5)	HANDLE (M5)	2
10	4.2.000.9246	BATENTE PRETO Nº2	BLACK KNOCKER NR. 2	4
11	4.1.000.6220	PEGADEIRA REF. 58 EM PVC	PVC HANDGRIP	1
12	4.0.087.0040	ANILHA FIXAÇÃO RAPIDA 6MM	FIXING RING 6MM	2
13	4.0.091.0031	CESTO CONJ. FF15TR	BASKET FF15	1
14	4.0.028.0035	CASQUILHO GUIA TAB. SUP. PACIFIC	BUSHING GUIDE TRAY TOP PACIFIC	1
15	7.0.085.1067	BLINDAGEM CAPILARES FF NV	CAPILLARY SHIELD FF NV	1

FRITADEIRA FF15TR

FRYER FF15TR

3 - CABEÇOTE MONTADO FF15TR - 7.0.091.0000

3- ELECTRIC UNIT ASS. FF15 TR

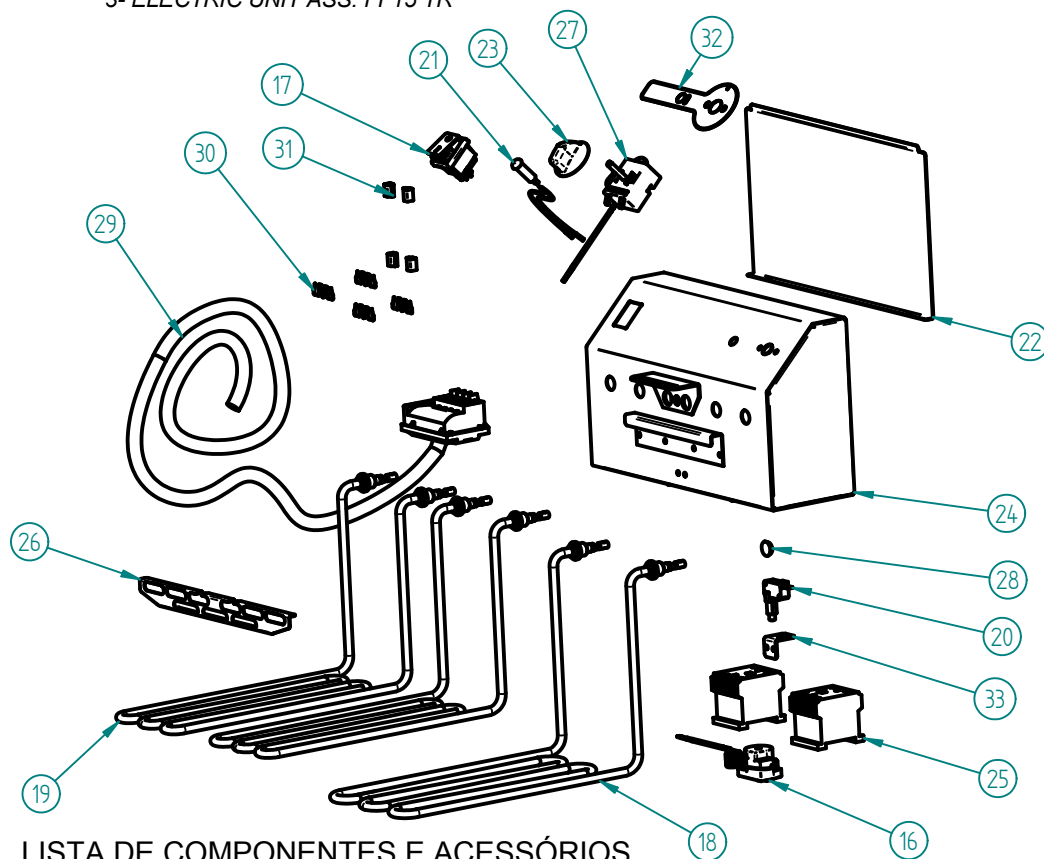

LISTA DE COMPONENTES E ACESSÓRIOS

Spare parts list

ITEM N°	CÓDIGO	DESIGNAÇÃO	DESIGNATION	QUANT.
16	4.0.085.0011	TERMOSTATO SEGURANÇA 220°	SAFETY THERMOSTAT 220°C	1
17	4.0.085.0018	INTERRUPTOR LARANJA 0-1 IP65	ORANGE SWITCH	1
18	4.0.091.0005	RESISTENCIA INFERIOR 3000W 230V FF15TR	LOWER HEATING ELEMENT 3000W 230V FF15TR	1
19	4.0.091.0004	RESISTENCIA SUPERIOR 3000W 230 V FF15TR	UPPER HEATING ELEMENT 3000W 230V FF15TR	2
20	4.0.085.0021	MICRO INTERRUPTOR RLP/A	MICRO SWITCH RLP/A	1
21	4.0.085.0022	SINALIZADOR LARANJA TER. PONT. 250MM SL10207	ORANGE LED 250MM	1
22	7.0.091.0050	TAMPA CASTELO FF15TR	ELECTRIC UNIT SHIELD COVER FF15TR	1
23	4.0.075.0040	MANIPULO TEMPORIZADOR	BUTTON	1
24	7.0.091.0025	CASTELO CONJUNTO FF15TR	SHIELD OF ELECTRIC UNIT	1
25	4.0.091.0003	CONTACTOR 22A-AC1 BOBINE 230V	CONTACTOR 22A-AC1 230V	2
26	7.0.091.0065	SEPARADOR RESISTENCIA FF15TR	HEATING ELEMENT ISOLATOR FF15TR	1
27	4.0.085.0009	TERMOSTATO REGULAVEL 180°	ADJUSTABLE THERMOSTAT 180°C	1
28	4.0.085.0035	TAPA FUROS Ø10MM	RUBBER COVER Ø10MM	1
29	7.0.091.0080	CABO H07RN-F 5G2,5-2,0MT S/ FICHA+CC	FEEDING CABLE ASS. FF15 TR	1
30	4.0.085.0114	MOLA ARAME P/ BOLBO	SPRING	4
31	4.0.085.0017	MOLA P/ CAPILARES	WIRE SPRING	4
32	4.0.190.0050	PAINEL PERSONALIZADO FIAMMA FCF	STICKER FCF FIAMMA	1
33	7.0.085.1026	FIXADOR MICRO INTERRUPTOR FF NV	MICRO SWITCH FIXER	1

FRITADEIRA FF15TR

FRYER FF15TR

29 -CABO H07RN-F 5G2,5-2,0MT S/ FICHA+CC) - 7.0.091.0080

29- FEEDING CABLE ASS. FF15 TR

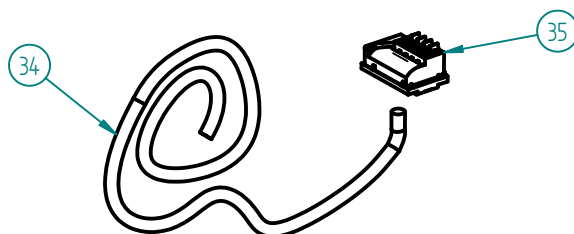

ITEM Nº	CÓDIGO	DESIGNAÇÃO	DESIGNATION	QUANT.
34	4.0.091.0010	CABO H07RN-F 5G2,5	CABLE H07RN-F 5G2,5	1
35	4.0.089.0014	CERRA CABOS A0030T	CABLE FASTENER	1

ESQUEMA ELECTRICO

Electric Scheme

