

EH330 and EH430 Service Parts

This part list contains the service parts for the Eclipse 1200, 1400, 1800 and 2000 systems.

The models that are covered include:

- EH330
- EH430
- C1200CP
- C1410CP
- C1800CP
- C2000CP
- ERC1086
- ERC2086

Table of Contents

EH330 Cabinet	Page 2
EH430 Cabinet	Page 3
EH330 and EH430 Interior Parts	Page 4
EH330 and EH430 Refrigeration System	Page 5
EH330 Evaporator Compartment	Page 6
EH430 Evaporator Compartment	Page 7
EH330 or EH430 Electrical	Page 8
CP Cabinet	Page 9
C1200CP Refrigeration System	Page 10
C1410CP Refrigeration Systems	Page 11
C1800CP Refrigeration System	Page 12
C2000CP Refrigeration System	Page 13
CP Control Box	Page 14
Remote Condensers	Page 15
EH330 or EH430 Schematic Diagram	Page 16
EH330 or EH430 Wiring Diagram	Page 17
CP Single Phase Schematic Diagram	Page 18
CP Single Phase Wiring Diagram	Page 19
CP Three Phase Wiring Diagram	Page 20
CP Three Phase Schematic Diagram	Page 21

EH330 and EH430 Service Parts

EH430 Cabinet

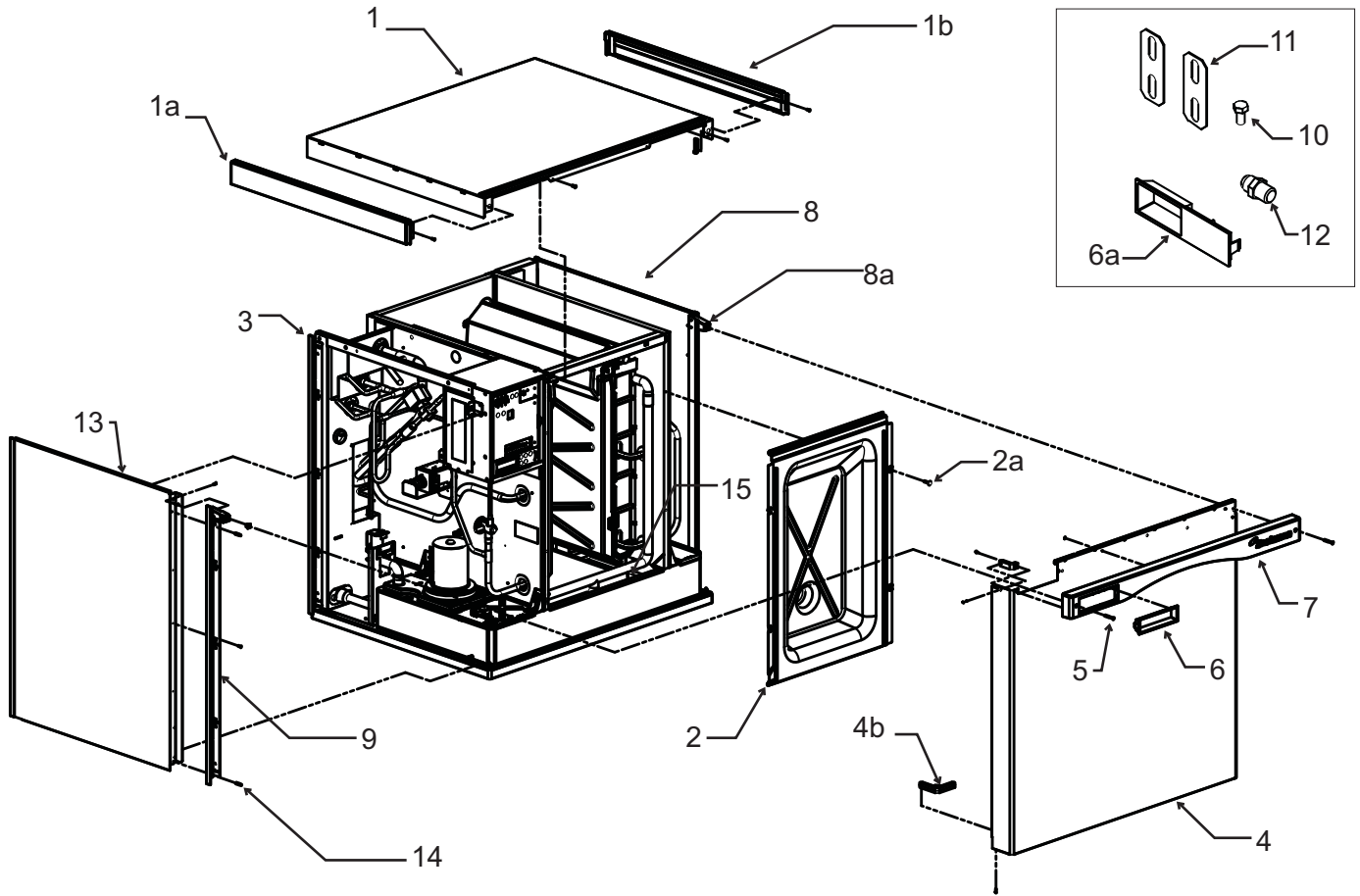

Item Number	Part Number	Description	Item Number	Part Number	Description
1	A38941-022	Top panel, w/trim strips	8a	02-4215-01	Receptacle
1a	02-4221-01	Left trim strip	9	02-4067-03	Side panel support
1b	02-4221-02	Right trim strip	10	03-1405-15	Screw
2	02-4184-01	Evaporator cover	11	A30911-015	Machine straps
2a	03-0727-05	Screw	12	16-0355-00	Inlet water fitting, flare
3	02-4067-03	Side panel support	13	A38551-024	Left side panel
4	A38552-023	Front panel assembly, includes trim strip, gussets and labels.	14	03-1404-12	Screw
4a	02-4216-01	Top gusset	15	13-0943-01	Gasket tape
4b	02-4217-01	Bottom gusset			
5	03-1735-03	Screw, front panel			
6	02-4284-01	Bezel, full window			
6a	02-4284-02	Bezel, partial window			
7	02-4214-02	Trim strip			
8	A38553-022	Right side panel assy			

EH330 and EH430 Service Parts

EH330 and EH430 Interior Parts

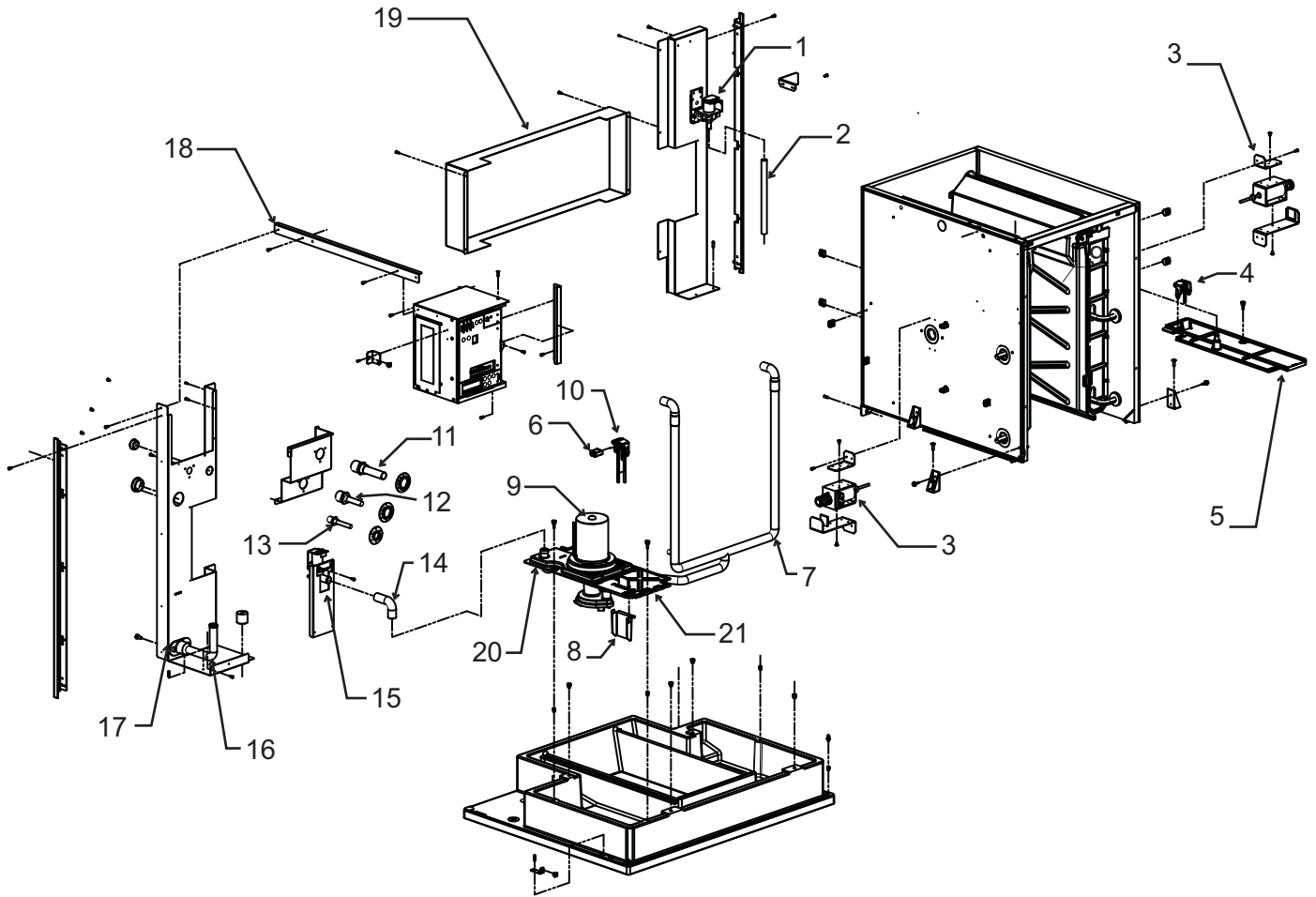

Item Number	Part Number	Description
1	12-2922-01	Inlet water sol valve
2	13-0674-02	Tubing, order 2 (ft)
3	12-2934-21	Harvest assist sol. EH430
	12-2918-21	Harvest assist sol. EH330 includes brackets
4	A39030-022	Level sensor
5	02-4175-01	Sump cover, rt
6	12-2928-02	WLS harness
7	02-4182-01	Water pump hose, EH430
	02-4505-01	Water pump hose, EH330
8	02-4332-01	WLS cover
9	12-2920-21	Water pump
10	A39030-021	Water level sensor
11	16-0850-04	Suction line fitting
	12	16-0850-01 Vapor line fitting
	13	16-0850-03 Liquid line fitting
	14	A38863-001 Tube
	15	11-0564-01 Purge valve
	16	A38863-002 Tube, out
	17	02-3692-21 Drain fitting
	18	A38804-001 Brace
	19	A38796-001 Chase
	20	02-4177-01 Pump bracket
	21	02-4178-01 Sump cover

EH330 and EH430 Service Parts

EH330 and EH430 Refrigeration System

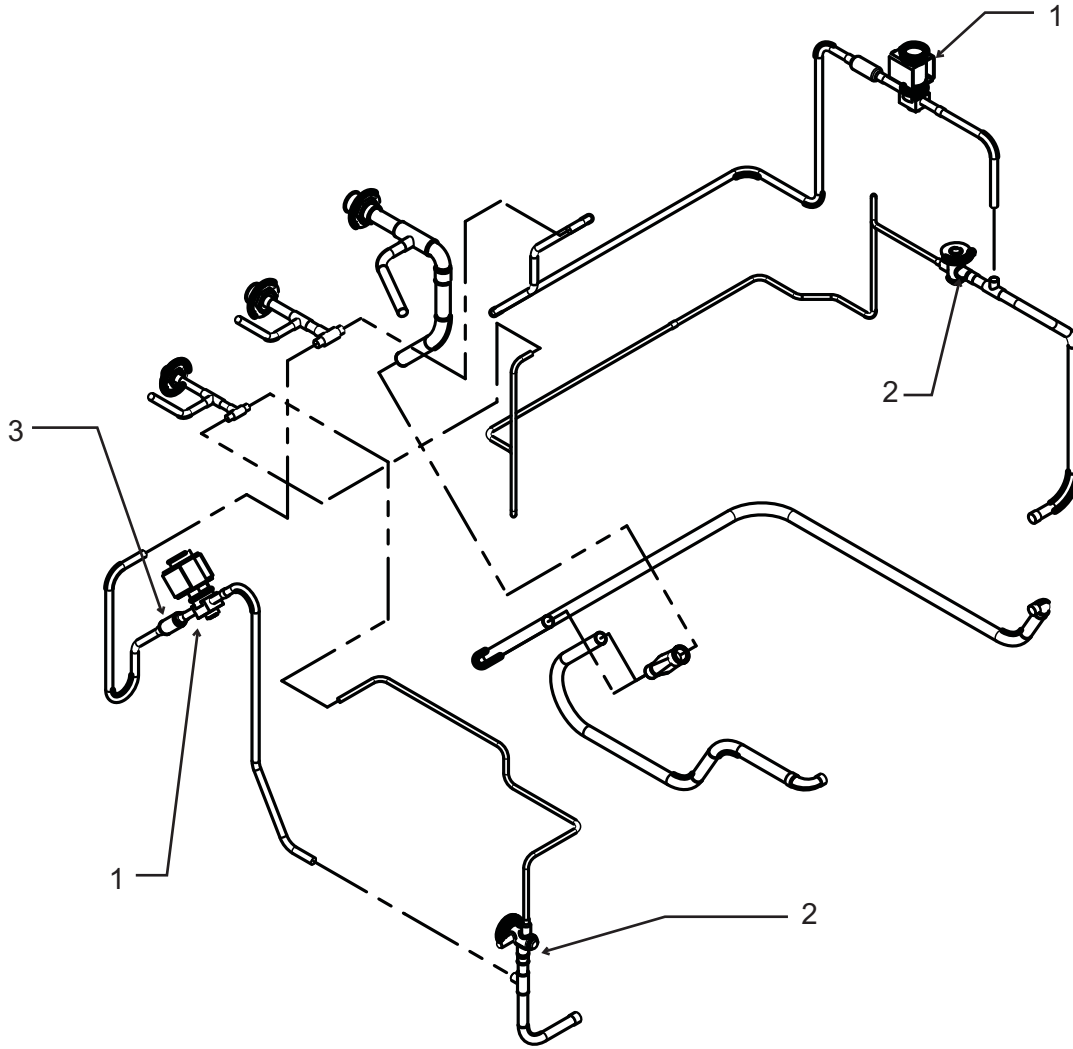

Item Number	Part Number	Description
1	11-0493-03	Vapor valve
2	16-1130-01	TXV - EH430
	16-1142-01	TXV - EH330
	02-4045-01	Insulation for TXV
3	16-1063-01	Strainer

EH330 and EH430 Service Parts

EH430 Evaporator Compartment

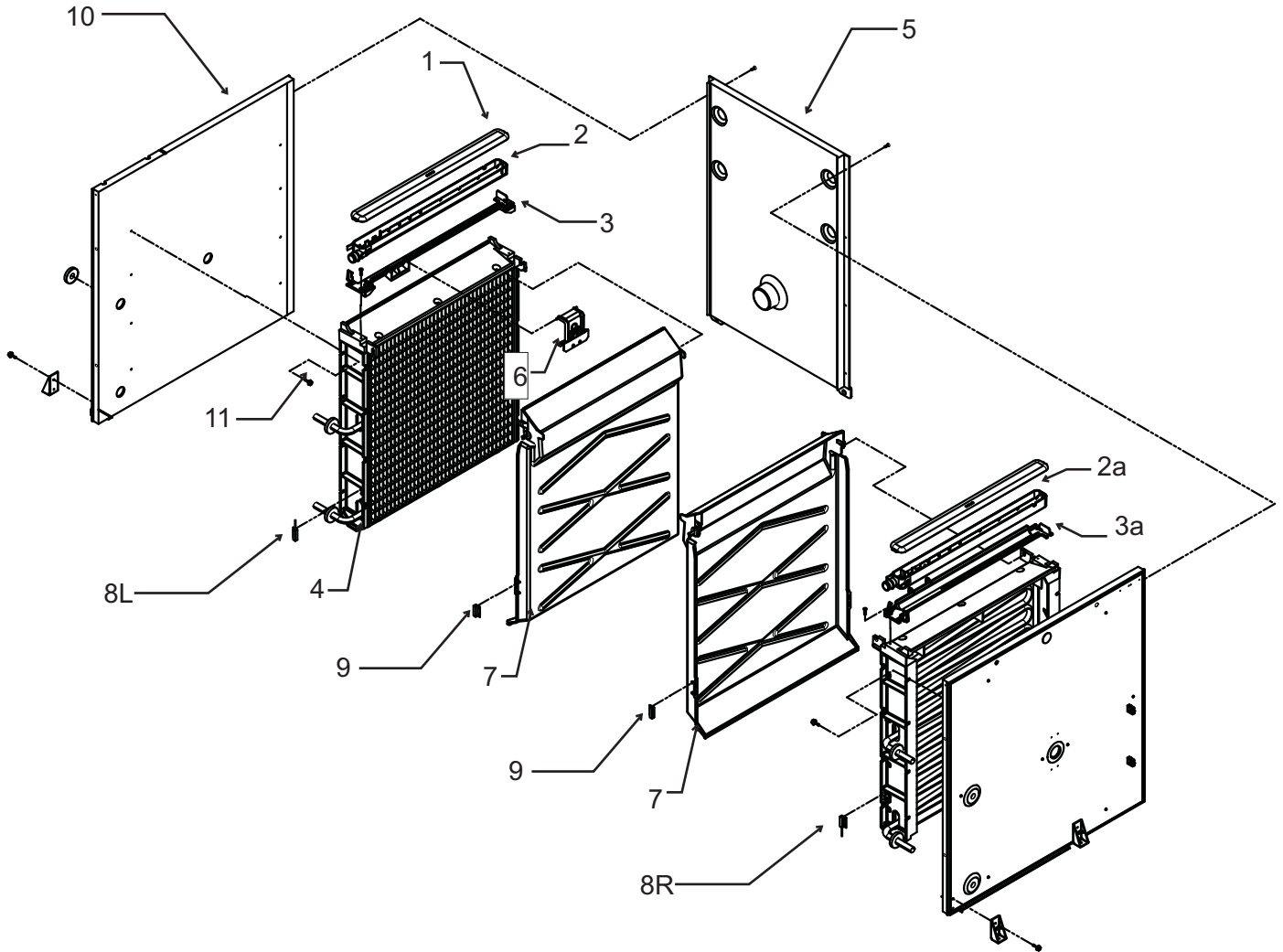

Item Number	Part Number	Description	8L	11-0563-06	Curtain switch, left
1	02-4065-01	Water distributor cover	8R	11-0563-03	Curtain switch, right
2	02-4064-01	Water distributor, left	9	11-0563-02	Curtain switch magnet
2a	02-4064-02	Water distributor, right	10	13-0943-01	Gasket tape
3	02-4205-01	Mounting bracket, left	11	03-3868-01	Screw
3a	02-4205-02	Mounting bracket, right	Note: Item 7 includes item 9, shipped loose.		
4	see table	Evaporator			

	small cube	medium cube
Right	A38628-023	A38628-024
Left	A38628-021	A38628-022

5	A38677-001	Back wall
6	A39031-021	Ice thickness sensor
7	02-4100-23	Curtain

EH330 and EH430 Service Parts

EH330 or EH430 Electrical

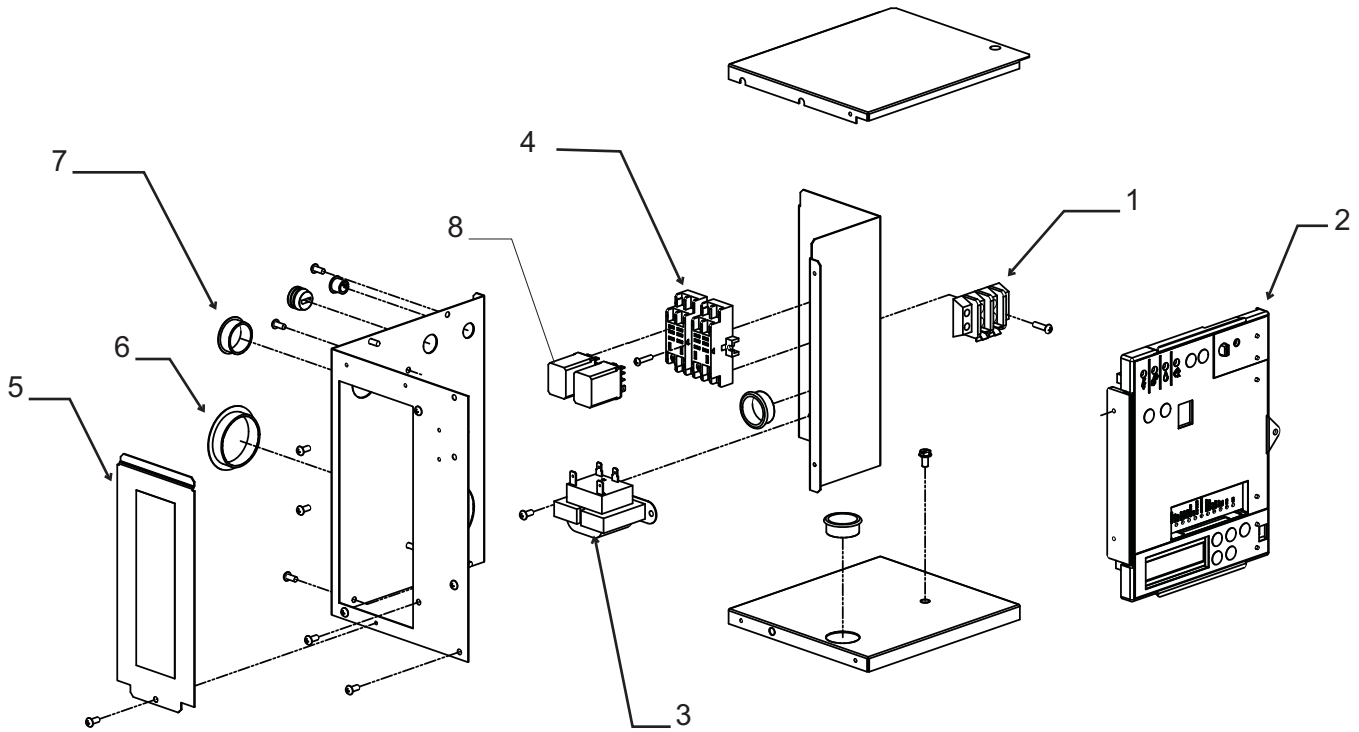

Item Number	Part Number	Description
1	12-2780-01	Terminal strip
2	11-0550-24	Controller
3	12-2924-01	Transformer
4	12-2949-02	Relay base
5	A39287-001	Cover
6	12-1213-15	Snap bushing
7	12-1213-11	Snap bushing

Not Illustrated:

9	12-2954-01	Low voltage harness - to interconnecting wire
10	12-2943-01	High voltage harness (has large plug)
11	12-2940-01	Control power harness

EH330 and EH430 Service Parts

Remote Condensers

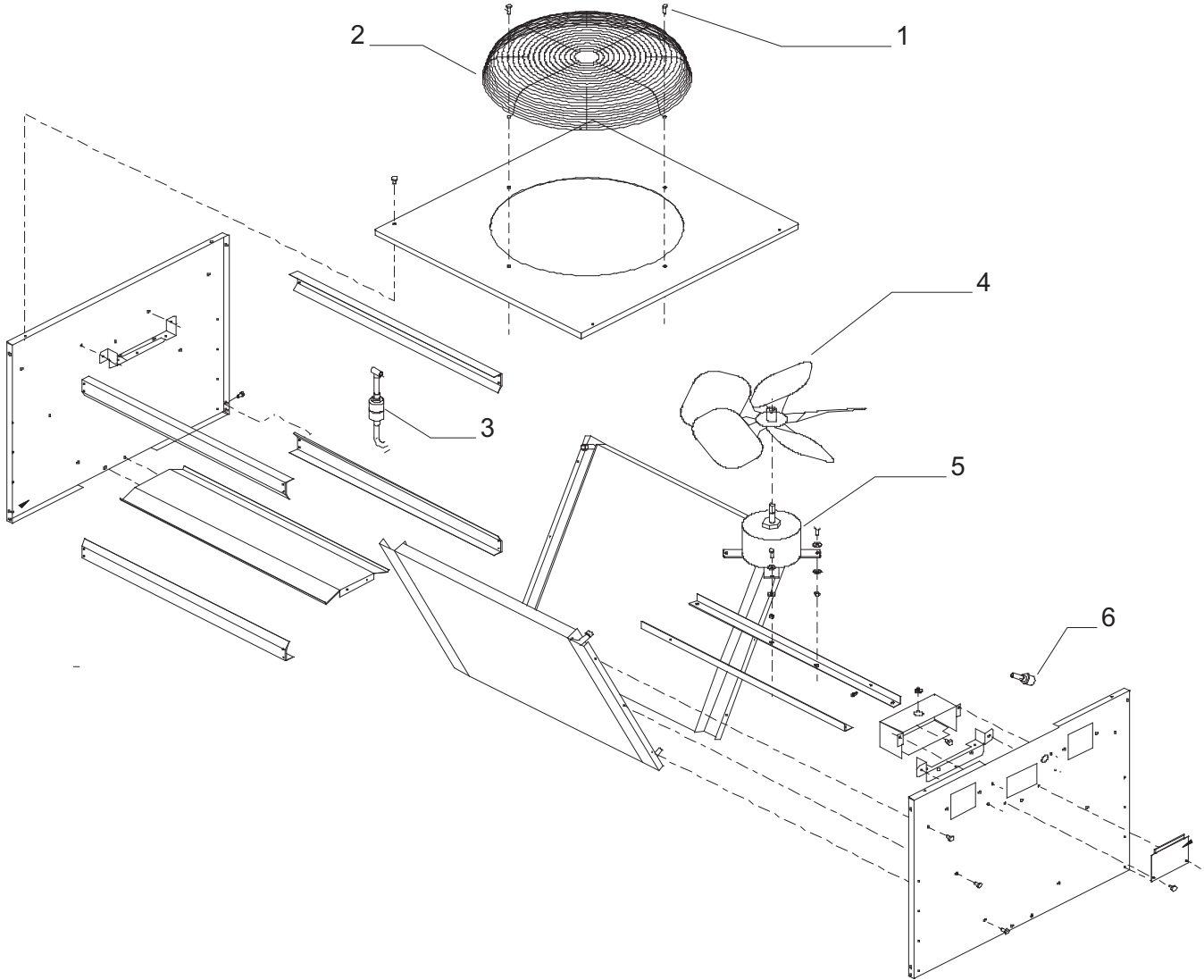

Model ERC1086

Item Number	Part Number	Description
1	03-1405-08	Screw
2	02-3575-01	Fan guard
3	02-3231-03	Filter
4	18-8816-01	Fan blade
5	12-2651-01	Fan motor
6	16-1057-04	Quick connect, disch
	16-1057-03	Quick connect, liquid

Not Shown:

A37169-001	Leg
A37170-001	Leg brace
03-1645-01	Screw for legs

ERC2086

Item Number	Part Number	Description
1	03-1405-08	Screw
2	02-3770-01	Fan guard
3	02-3231-03	Filter
4	18-8820-01	Fan blade
5	12-2717-01	Fan motor
6	16-1057-04	Quick connect, disch
	16-1057-03	Quick connect, liquid

Not Shown:

A37169-001	Leg
A37296-001	Leg brace
03-1645-01	Screw for legs

EH330 and EH430 Wiring Diagrams

EH330 or EH430 Schematic Diagram

