



**Applus®**  
LGA I  
Organismo  
Notificado  
**0370**

**AENOR**  
Organismo  
Notificado  
**0099**



TOLERANCIAS GENERALES: ±0.5 mm

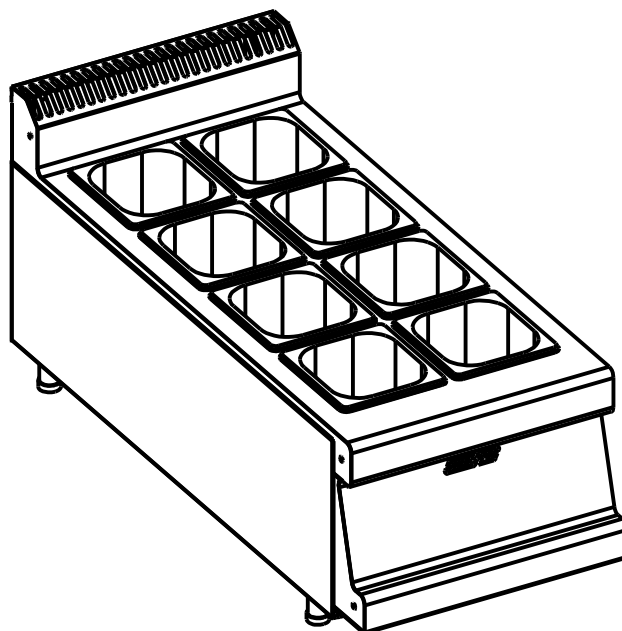
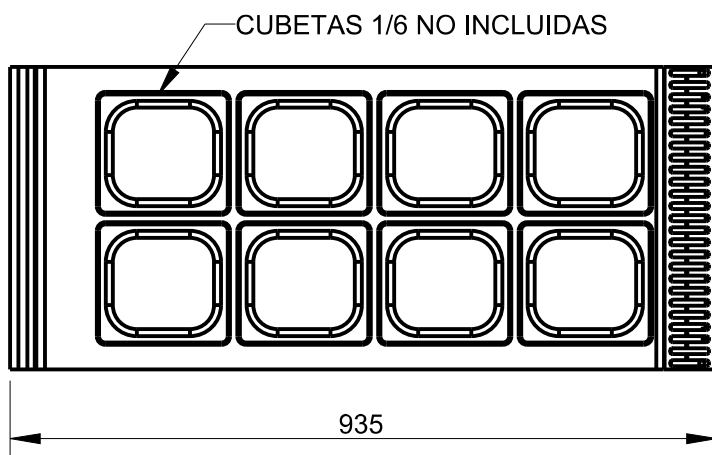
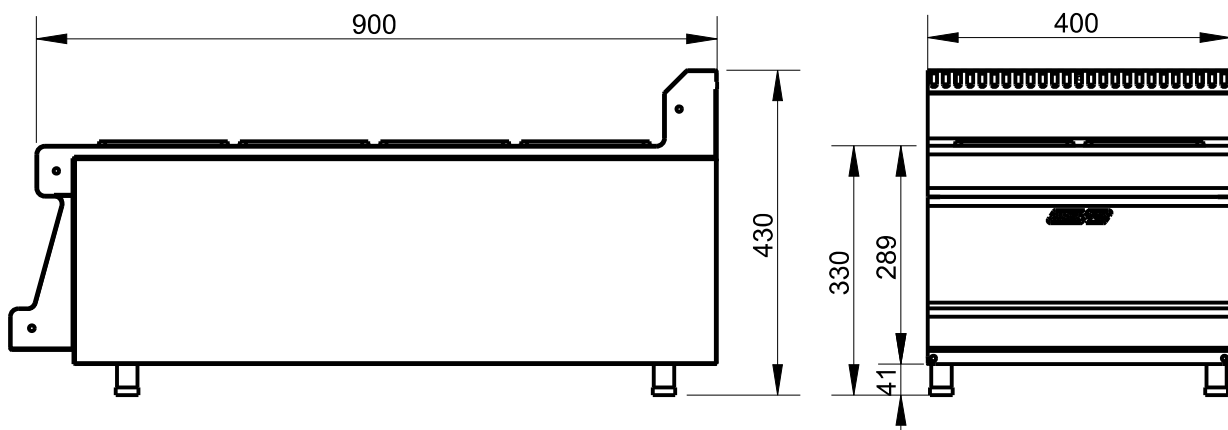

FAMILIA: COCINAS 2008

FECHA: 21/01/11

MODELO: 3801/3S

PESO(Kg): 20.617

DENOMINACION:  
SALSERA SOBREMESA 400X900

ESCALA:  
1/10

MATERIAL:  
INOX

CODIGO:  
3801/3S



**Applus®**  
LGA1  
Organismo  
Notificado  
**0370**

**AENOR**  
Organismo  
Notificado  
**0099**



TOLERANCIAS GENERALES: ±0.5 mm

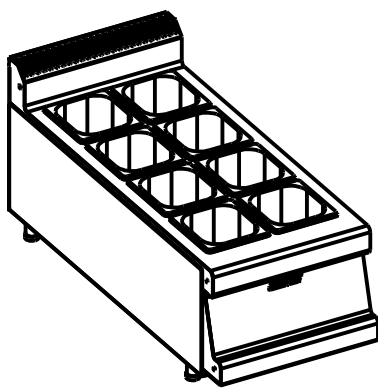

QT	COD	DESCRIPCION
4	6038	PATA REGULABLE AP.SNACK
1	330913	TRASERO HORNILLO 400
1	350465	FRONTAL INFERIOR 400
1	3801143	REFUERZO SALSERA
1	340208M	CONJ. LAT.SUPERIOR 900 DCH
1	340209M	CONJ. LAT.SUPERIOR 900 IZQ
1	3801013C	CONJ.SOBRE SALSERA 400X900
1	380739C	CONJ.FR.MAN.NEUTRO 400
8	C6440409	CUBETA GN 1/6-200

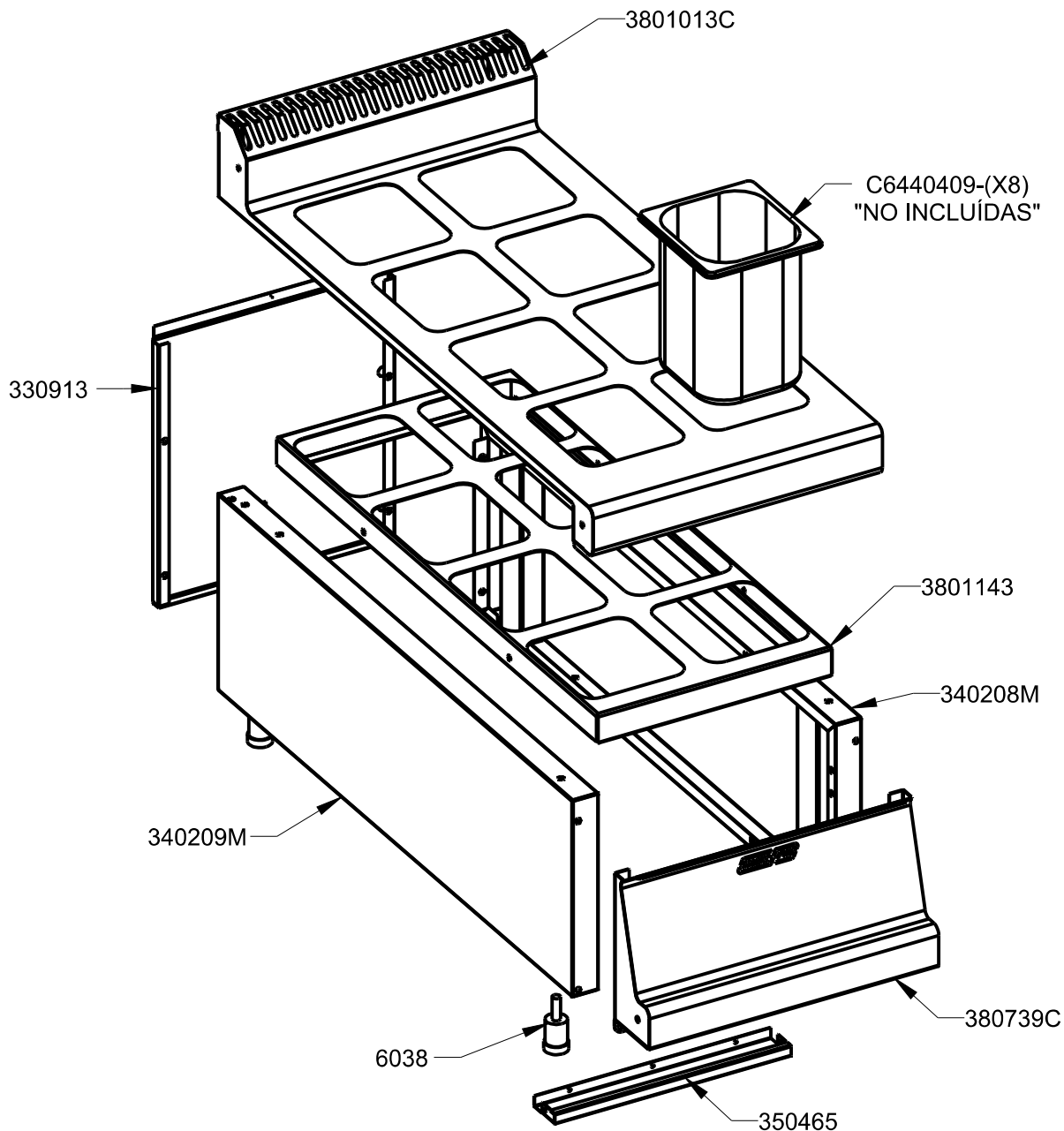

FAMILIA: COCINAS 2008

FECHA: 21/01/11

MODELO: 3801/3S

PESO(Kg): 20.617

DENOMINACION:  
SALSERA SOBREMESA 400X900

ESCALA:  
1/8

MATERIAL:  
INOX

CODIGO:  
3801/3S



**Applus®**  
LGA1  
Organismo  
Notificado  
**0370**

**AENOR**  
Organismo  
Notificado  
**0099**



TOLERANCIAS GENERALES: ±0.5 mm

QT	COD	DESCRIPCION	FAB.	MATERIAL	DATA	PESO
3	330675	REFUERZO PATA	SÍ	GALVA 1.5	11/12/08	0.429
1	330913	TRASERO HORNILLO 400	SÍ	INOFER 0.8	11/12/08	0.931
1	340208	LATERAL SUPERIOR 900 DCHO	SÍ	INOFER 0.8	10/03/09	2.168
1	340209	LATERAL SUPERIOR 900 IZQ.	SÍ	INOFER 0.8	10/03/09	2.168
1	350465	FRONTAL INFERIOR 400	SÍ	INOFER 0.8	15/06/10	0.180
1	380140	LATERAL IZQUIERDO SOBRE 900	SÍ	INOFER 1.2	03/03/09	0.353
1	380141	LATERAL DERECHO SOBRE 900	SÍ	INOFER 1.2	03/03/09	0.353
1	380739	FRONTAL MANDOS NEUTRO 400	SÍ	INOX 1.2	27/10/09	1.304
1	380778	TAPETA LATERAL DERECHA FRONTAL	SÍ	INOFER 1.2	25/02/09	0.121
1	380779	TAPETA LATERAL IZQ. FRONTAL	SÍ	INOFER 1.2	26/06/07	0.121
1	3306751	REFUERZO PATA C/ENCAJE BATERIA	SÍ	GALVA 1.5	09/01/09	0.361
1	3801013	SOBRE SALSERA 400X900	SÍ	INOX 1.2	14/01/11	2.238
1	3801143	REFUERZO SALSERA	SÍ	GALVA 1.5	21/01/11	2.051
1	340208M	CONJ. LAT.SUPERIOR 900 DCH	SÍ	INOX	17/01/11	3.042
1	340209M	CONJ. LAT.SUPERIOR 900 IZQ	SÍ	INOX	17/01/11	2.973
1	3801013C	CONJ.SOBRE SALSERA 400X900	SÍ	INOX	14/01/11	3.157
1	38013S	SALSERA SOBREMESA 400X900	SÍ	INOX	21/01/11	20.617
1	380739C	CONJ.FR.MAN.NEUTRO 400	SÍ	INOX	28/10/09	1.594
2	TESTA140	ANGULO TESTATINA 140	SÍ	INOX 0.6	29/08/07	0.016
6	TESTA35	ANGULO TESTATINA 35	SÍ	INOX 0.6	29/08/07	0.004
2	TESTA70	ANGULO TESTATINA 70	SÍ	INOX 0.6	29/08/07	0.008
2	TESTA800	ANGULO TESTATINA 800	SÍ	INOX 0.6	19/08/07	0.094
4	1014	REMACHE ROSCADO M-10	NO	ZN	17/12/09	0.008
4	6038	PATA REGULABLE AP.SNACK	NO	BAQUELITA	01/12/93	0.068
8	C6440409	CUBETA GN 1/6-200	NO	INOX	05/11/10	0.826



FAMILIA: COCINAS 2008

FECHA: 21/01/11

MODELO: 3801/3S

PESO(Kg): 20.617

DENOMINACION:  
SALSERA SOBREMESA 400X900

ESCALA:  
1/10

MATERIAL:  
INOX

CODIGO:  
3801/3S