

7,8 kW	7,8 kW
7,8 kW	7,8 kW

K4FZS - K4FZSFG
K4FZSFE - K4FZSFCG
K4FZSFCE

6,0 kW
4,0 kW

K2FZ - OP2FZ

6,0 kW	7,8 kW
7,8 kW	4,0 kW

K4FZ - B4FZ - OP4FZ - K4FZFG/FE/FCG/FCE

6,0 kW	6,0 kW	7,8 kW
4,0 kW	7,8 kW	4,0 kW

K6FZ - B6FZ - OP6FZ - K6FZFG/FE/FCG/FCE/FGA

6,0 kW	6,0 kW	6,0 kW	7,8 kW
7,8 kW	4,0 kW	7,8 kW	4,0 kW

K8FZ - B8FZ - OP8FZ - K8FZFG/FE/FCG/FCE

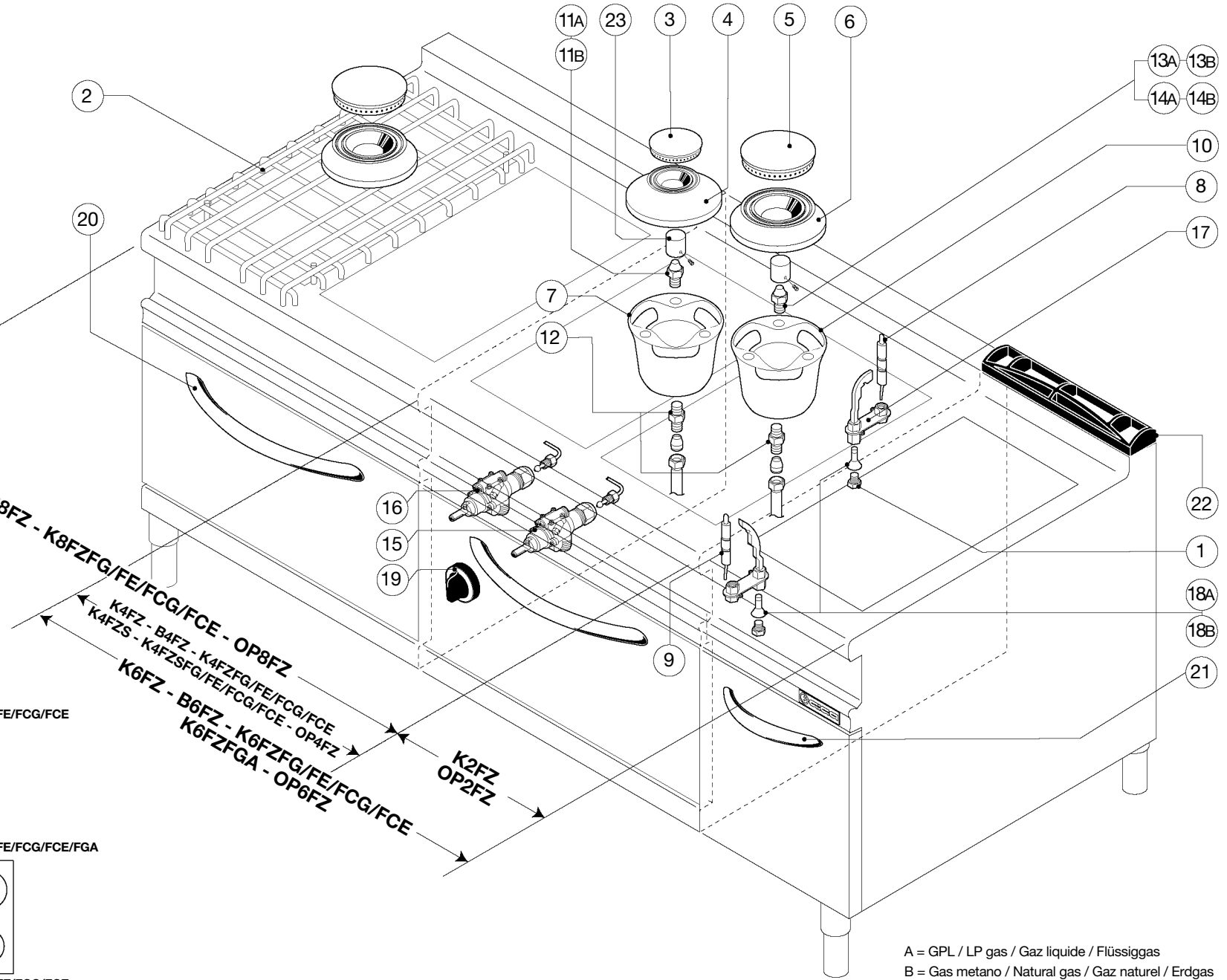

A = GPL / LP gas / Gaz liquide / Flüssiggas
B = Gas metano / Natural gas / Gaz naturel / Erdgas



N.B.: La tavola si completa con la successiva n. See table No. Voir tableau n. Wichtig: S. folgender Plan Nr.

•3E01-004 K4FZFG - K6FZFG K8FZFG - K4FZSFG	•3E01-005 K4FZFE - K6FZFE K8FZFE - K4FZSFE	•3E01-006 K4FZFCG - K4FZSFCG K6FZFCG - K8FZFCG	•3E01-007 K4FZFCE - K4FZSFCE K6FZFCE - K8FZFCE	•3E01-008 K6FZFGA
--	--	--	--	----------------------

3E01-012

K2FZ - K4FZ - K4FZS - K6FZ - K8FZ K4FZFG - K4FZFE - K4FZFCG - K4FEFCE K6FZFG - K6FZFE - K6FZFCG - K6FZFCE K8FZFG - K8FZFE - K8FZFCG - K8FZFCE K4FZSFG - K4FZSFE - K4FZSFCG - K4FZSFCG K4FZSFCG - K4FZSFCG - B4FZ - B6FZ - B8FZ OP2FZ - OP4FZ - OP6FZ - OP8FZ
--

Pezzi/Pieces Pieces/Anzahl									Pos.	Validità dalla matricola Validité du numéro matricule Validity from serial number Gültigkeit ab der (Seriennummer)	Validità alla matricola Validity up to serial number Validité au numéro matricule Gültigkeit bis zur (Seriennummer)	Codice Code Artikel Nummer	Descrizione	Description	Description	Beschreibung
K2FZ-OP2FZ	K4FZ-OP4FZ-B4FZ	K4FZS	K6FZ-OP6FZ-B4FZ	K8FZ-OPFZ-B8FZ	K4FZFG/FE/FCG/FCE	K4FZSFG/FE/FCG/FCE	K6FZFG/FE/FCG/FCE	K8FZFG/FE/FCG/FCE								
2	4	4	6	8	4	4	6	8	1			X13200	Dado fissaggio iniettore	Injector fastening nut	Ecrou de fixation injecteur	Befestigungsmutter Einspritzung
1	2	2	3	4	2	2	3	4	2			KG30	Griglia	Grid	Grille	Rost
1	1		2	2	1		2	2	3			V00300	Spartifiamma 4,0 kW	Flame spreader 4,0 kW	Diffuseur de flamme 4,0 kW	Flammenverteiler 4,0 kW
1	1		2	2	1		2	2	4			V00100	Corpo bruciatore 4,0 kW	Burner body 4,0 kW	Corps bruleur 4,0 kW	Brennerkörper 4,0 kW
1	3	4	4	6	3	4	4	6	5			V00400	Spartifiamma 6/7,8 kW	Flame spreader 6/7,8 kW	Diffuseur de flamme 6/7,8 kW	Flammenverteiler 6/7,8kW
1	3	4	4	6	3	4	4	6	6			V00200	Corpo bruciatore 6/7,8 kW	Burner body 6/7,8 kW	Corps bruleur 6/7,8 kW	Brennerkörper 6/7,8 kW
1	1		2	2	1		2	2	7			V01800	Coppa bruciatore 4,0 kW	Scoop burner 4,0 kW	Godet bruleur 4,0 kW	Brennerschale 4,0 kW
1	2	2	3	4	2	2	3	4	8			X13300	Termocoppia fuoco poster.	Rear ring thermocouple	Thermocouple feu poster.	Thermoel. Hintere kochst.
1	2	2	3	4	2	2	3	4	9			X14200	Termocoppia fuoco anter.	Front ring thermocouple	Thermocouple feu anter.	Thermoel. Vordere kochst.
1	3	4	4	6	3	4	4	6	10			V01900	Coppa bruciatore 6/7,8 kW	Cup burner 6/7,8 kW	Coupelle bruler 6/7,8 kW	Brennerkappe 6/7,8 kW
1	1		2	2	1		2	2	11A			X33600	Iniettore gpl fuoco 4,0 kW	Ring lpg injector 4,0 kW	Injecteur gpl feu 4,0 kW	Gasdüse gpl kochst. 4,0 kW
1	1		2	3	1		2	3	11B			X34600	Iniettore metano fuoco 4,0 kW	Ring natural gas inject. 4,0 kW	Injecteur methane feu 4,0 kW	Gasdüse methan kochst. 4,0 kW
2	4	4	6	8	2	4	6	8	12			V01100	Porta iniettore	Injector-holder	Porte-injecteur	Düsenträger
	2	4	2	3	2	4	2	3	13A			X34400	Iniettore 7,8 kW /GPL	LPG injector 7,8 kW	Injecteur gaz GPL 7,8 kW	Gasdüse GPL 7,8 kW
1	2	4	2	3	2	4	2	3	13B			X35700	Iniettore 7,8 kW/metano	Natural gas injector 7,8 kW	Injecteur gaz methane 7,8 kW	Gasdüse Methan 7,8 kW
1	1		2	3	1		2	3	14A			X34200	Iniettore 6,0 kW /GPL	LPG injector 6,0 kW	Injecteur gaz GPL 6,0 kW	Gasdüse GPL 6,0 kW
1	1		2	2	1		2	2	14B			X35200	Iniettore 6,0 kW/metano	Natural gas injector 6,0 kW	Injecteur gaz methane 6,0 kW	Gasdüse Methan 6,0 kW
1	1		2	2	1		2	2	15			3000X10500	Rubinetto fuoco 4,0 kW	Gas ring cock 4,0 kW	Robinet feu 4,0 kW	Gashan kochstelle 4,0 kW
1	3	4	4	6	3	4	4	6	16			4000X10500	Rubinetto fuoco 6,0/7,8 kW	Gas ring cock 6,0/7,8 kW	Robinet feu 6,0/7,8 kW	Gashan kochstelle 6,0/7,8 kW
2	4	4	6	8	4	4	6	8	17			X14400	Pilota	Pilot	Veilleuse d'allumage	Zündflammenbrenner
2	4	4	6	8	4	4	6	8	18A			X30000	Iniettore pilota/GPL	LPG injector	Injecteur gaz GPL	Gasdüse GPL
2	4	4	6	8	4	4	6	8	18B			X30300	Iniettore pilota/metano	Natural gas injector	Injecteur gaz methane	Gasdüse Methan
2	4	4	6	8	4	4	6	8	19			Y65103	Manopola per fuoco	Gas ring knob	Cle de commande pour feu	Drehknopf für kochstelle
	1	1	1	2	1	1	1	2	20			Y65700	Maniglia forno	Oven handle	Poignée four	Backofengriff
			1				1		21			Y65500	Maniglia porta	Door handle	Pognée four	Turgriff
1	2	2	3	4	2	2	3	4	22			1550Y63500	Griglia scarico fumi	Smoke discharge grid	Grille évacuation des fumées	Rauchblässgitter
2	4	4	6	8	4	4	6	8	23			V01500	Regolazione aria bruciatore	Burner air regulation	Règlage air bruler	Luftregelung Brenner

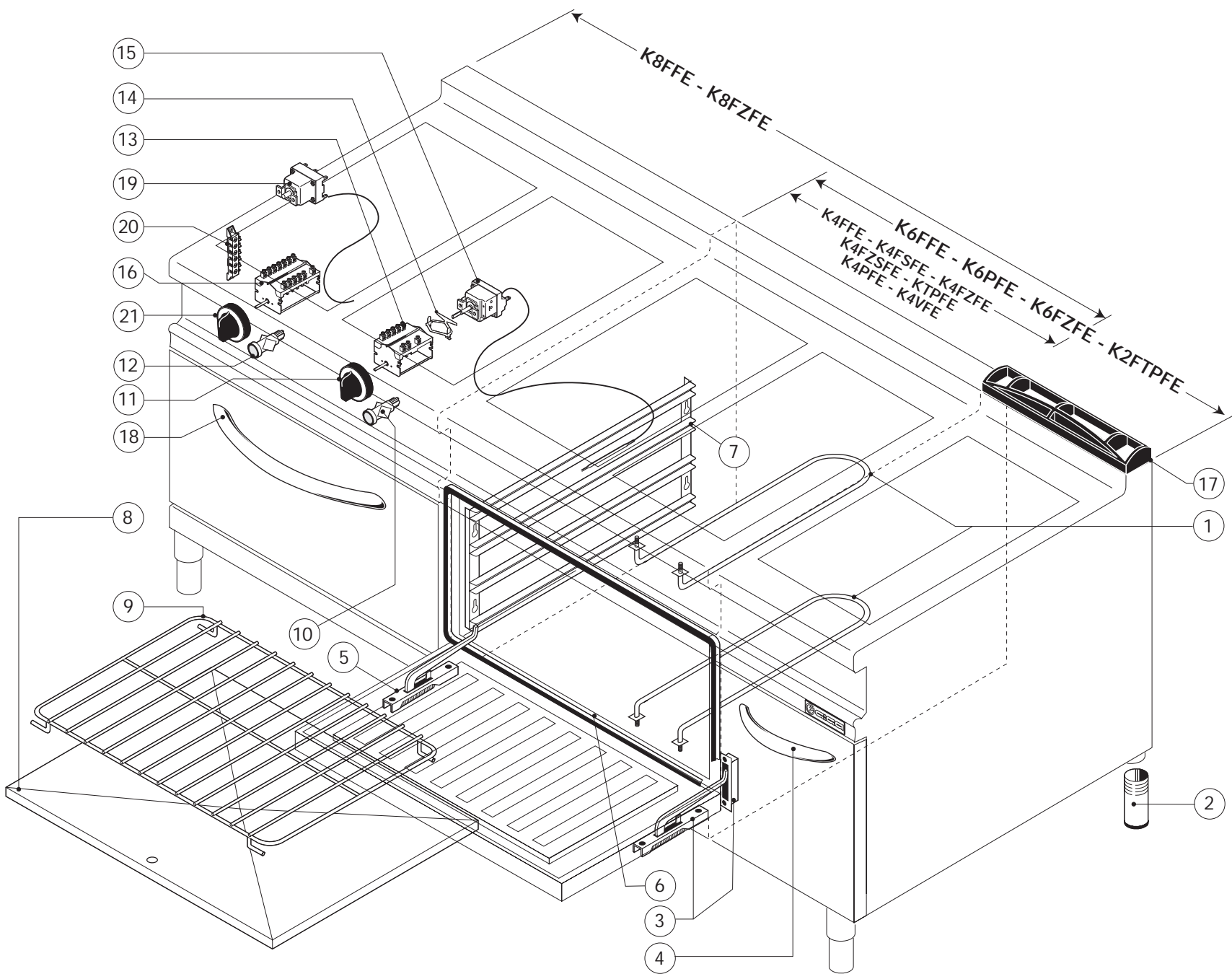

N.B.: La tavola si completa con la successiva n° - See table No. - Voir tableau n° - Wichtig: S. folgender Plan Nr.

• 3E01-003
K4FFE - K6FFE - K8FFE
K4FSFE

• 3E01-012
K4FZFE - K6FZFE
K8FZFE - K4ZSFE

• 3E01-014
K2FTPFE

• 3E01-015
K4PFE - K6PFE
• 3E01-016
K4VFE

3E01-005

K4FFE-K4FSFE-K4FZFE-K4ZSFE-K2FTPFE
K6FFE-K6FZFE-K2FTPFE-K8FFE-K8FZFE
K4PFE - K6PFE - K4VFE

Pezzi/Pieces Pieces/Anzahl			Pos.	Validità dalla matricola Validité du numéro matricule Validity from serial number Gültigkeit ab der (Seriennummer)	Validità alla matricola Validity up to serial number Validité au numéro matricule Gültigkeit bis zur (Seriennummer)	Codice Code Artikel Nummer	Descrizione	Description	Description	Beschreibung
K4FZFE K4FFE K4FZSFE K4FSFE KTPFE K4VFE	K6FZFE K6FFE KFSFE K2FTPF K6PFE	K8FZFE K8FFE								
6	6	12	1			X47000	Resistenza	Resistance	Resistance	Resistenz
4	4	4	2			Y40400	Piedino	Foot	Pied	Fuss
1	1	2	3			X66000	Cerniera dx	R. H. Hinge	Charniere droite	Scharnier rechts
	1		4			Y65500	Maniglia porta	Door handle	Pognée four	Turgriff
1	1	2	5			X66100	Cerniera sx	L. H. Hinge	Charniere gauche	Scharnier links
1	1	2	6			0000X05600	Guarnizione porta	Door seal	Joint porte	Türdichtung
2	2	4	7			B85500	Reggigriglia dx-sx	L.H.-R.H. Grid support	Appui grille droite/gauche	Rostauflegeschiene R.-L.
1	1	2	8			B88700	Suola forno elettrico	Electric oven floor	Sole four électrique	Boden Elektroofen
1	1	2	9			G21P	Griglia	Grid	Grille	Rost
1	1	2	10			X50900	Lampada verde	Green light	Lampe vert	Grüne Kontrollampe
1	1	2	11			0000Y65004	Manopola temperatura	Oven temp.	Cle de commande temper.	Drehknopf temp.
1	1	2	12			X41200	Lampada gialla	Yellow light	Lampe jaune	Gelbe Kontrollampe
1	1	2	13			X49700	Commutatore	Selector switch	Commutateur	Schalter
1	1	2	14			X44600	Staffa per collegamento	Connecting bracket	Collier de raccordement	Anschlussbügel
1	1	2	15			X43200	Termostato 50-300°C forno	Oven thermostat 50-300°C	Thermostat 50-300°C four	Thermostat 50-300°C Ofen
1	1	2	16			X44100	Commutatore 4 posizioni	4-Pos. selector switch	Commutateur 4 positions	4 Positionenschalte
1	1	2	17			1550Y63500	Griglia scarico fumi	Smoke discharge grid	Grille évacuation des fumées	Rauchblassgitter
1	1	2	18			Y65700	Maniglia forno	Oven handle	Poignée four	Backofengriff
1	1	2	19			X44800	Termostato di sicurezza	Safety thermostat	Thermostat de securite	Sicherheitsthermostat
1	1	1	20			X59200	Morsettiera	Terminal board	Barrette de raccordement	Klemmleiste
1	1	2	21			0000Y65011	Manopola 4 posizioni	4 position knob	Manette 4 positions	Schaltknopf 4 Positionen