

	*	**
G30-28+30mbar G31- 37mbar	533020200	533044000
G30- 50mbar	533020200	533030900
G20- 20mbar G25- 25mbar	533020400	533014300
G20- 20mbar DE-AT	533020400	533014300
G25- 20mbar	533020400	533056500
G25- 25mbar NL	533020400	533056000

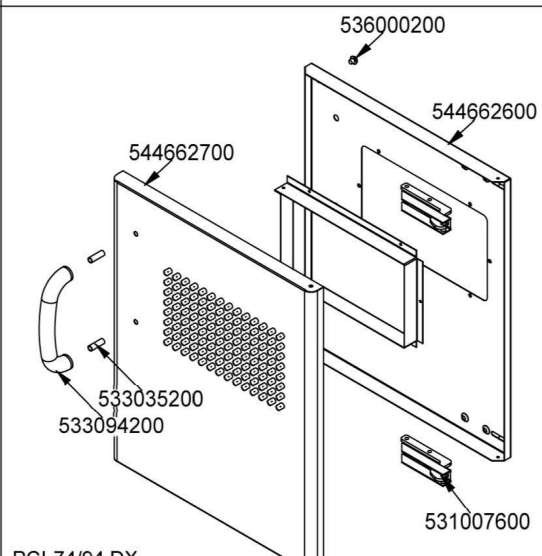

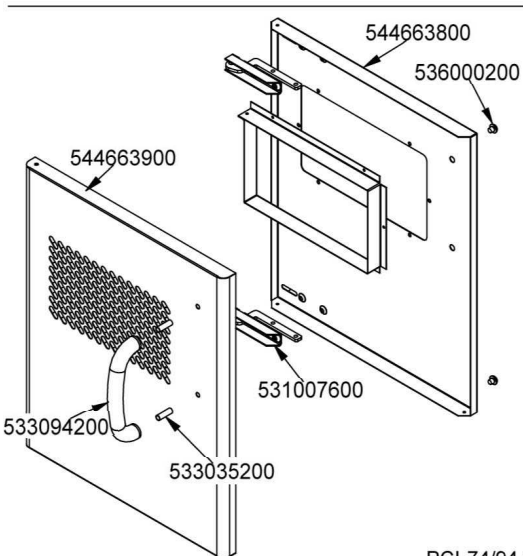

	*	**
G30-28+30mbar G31- 37mbar	533020200	533031000
G30- 50mbar	533020200	533055200
G20- 20mbar G25- 25mbar	533020400	533055800
G20- 20mbar DE-AT	533020400	533055800
G25- 20mbar	533020400	533055600
G25- 25mbar NL	533020400	533055900

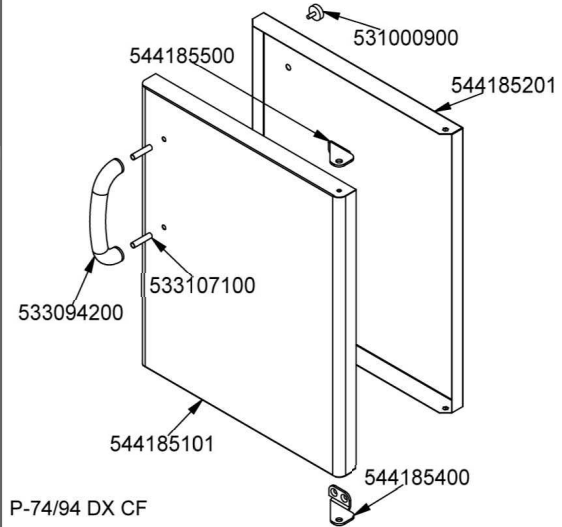
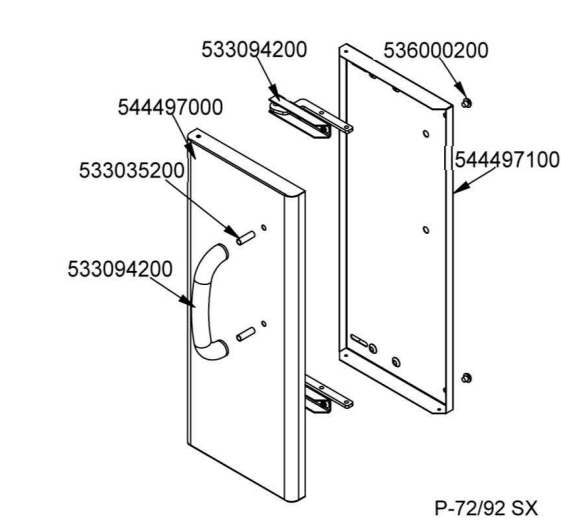
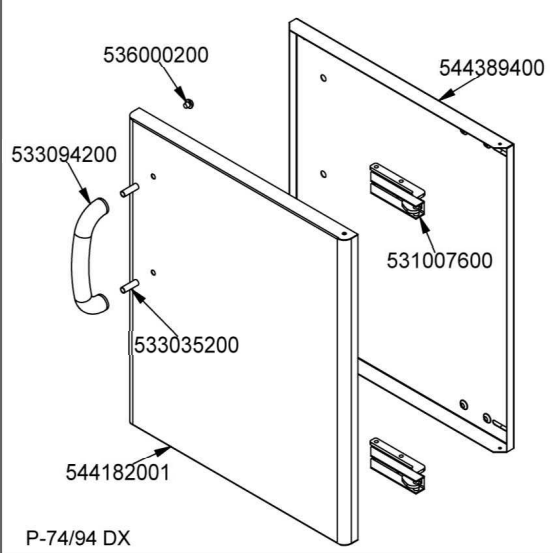
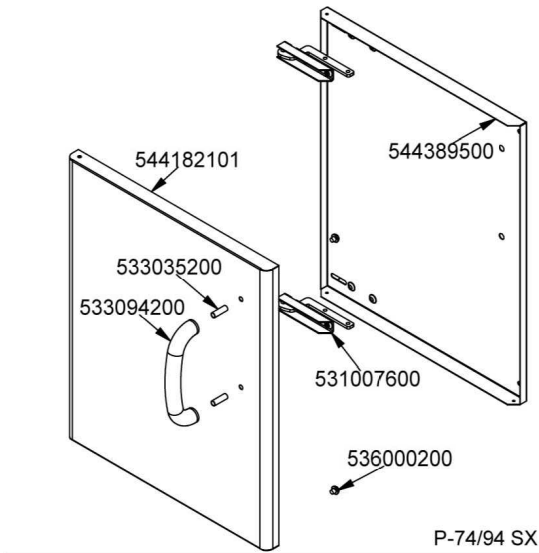
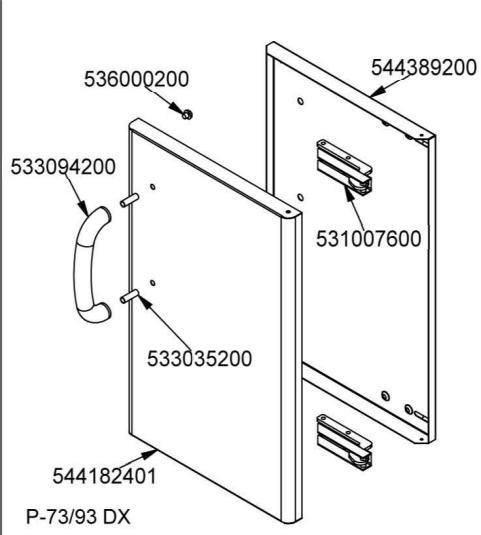
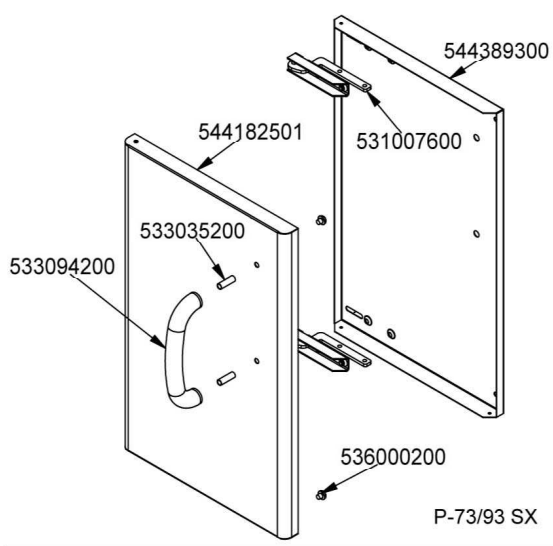
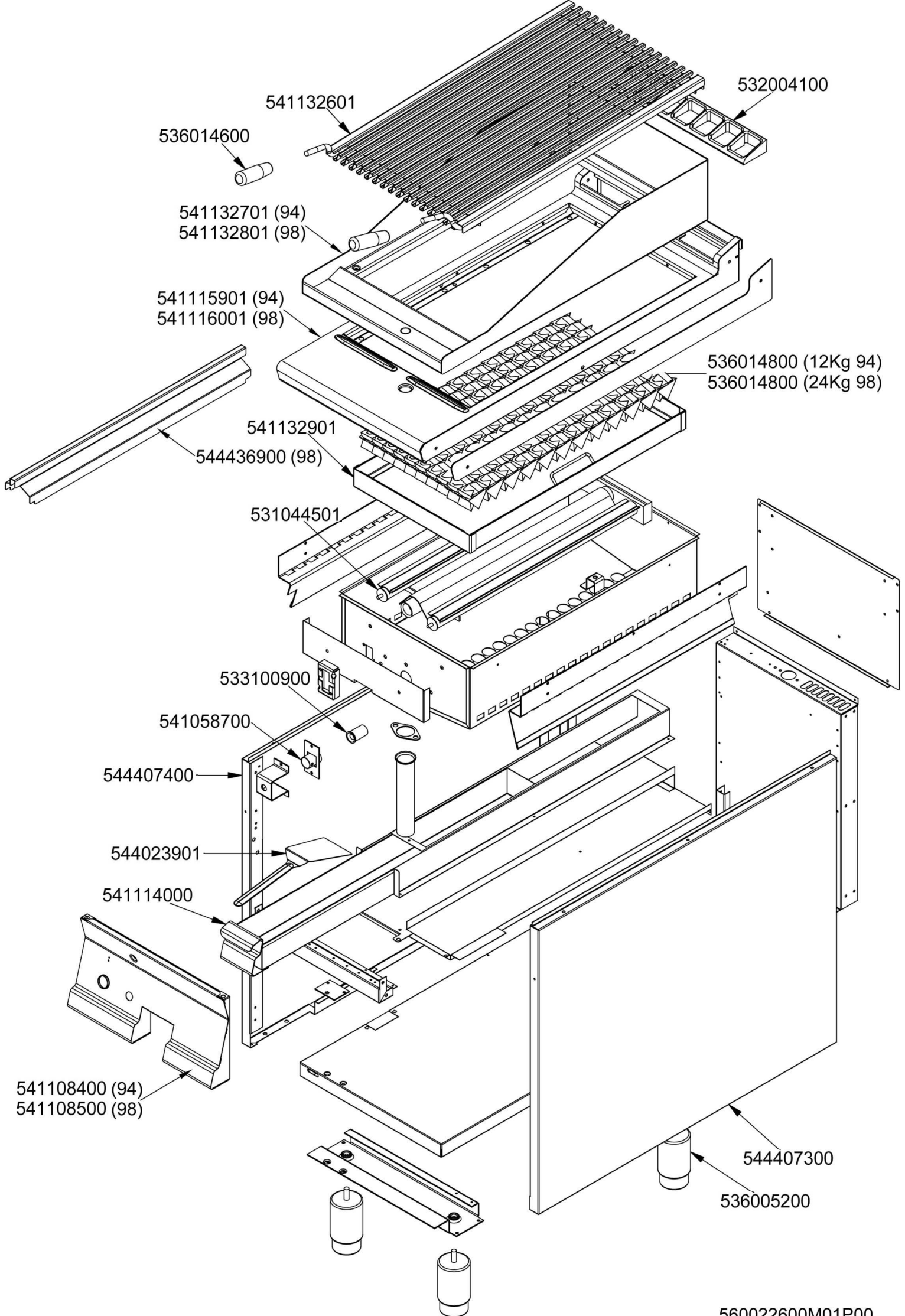
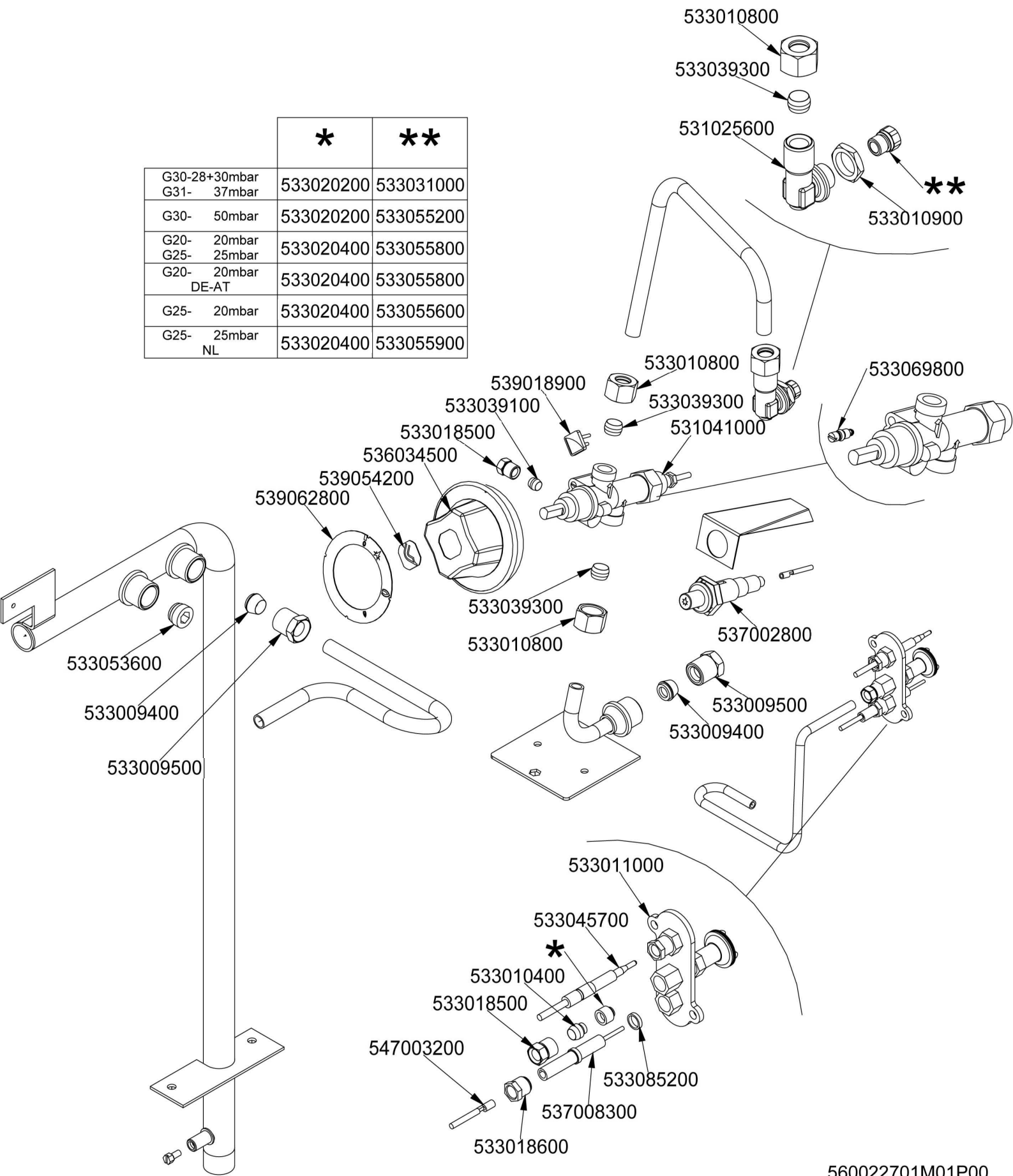

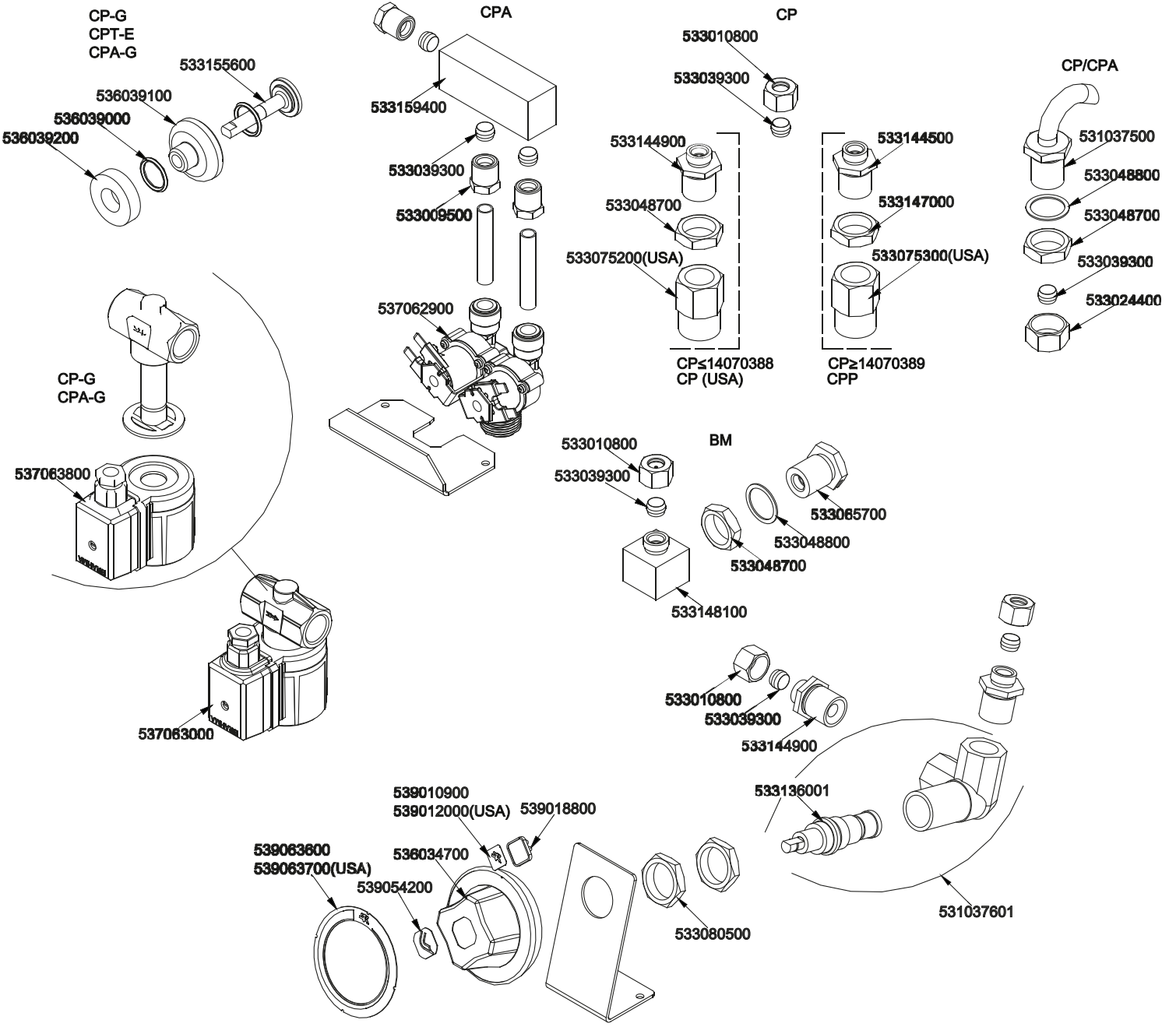

BR BRM-G

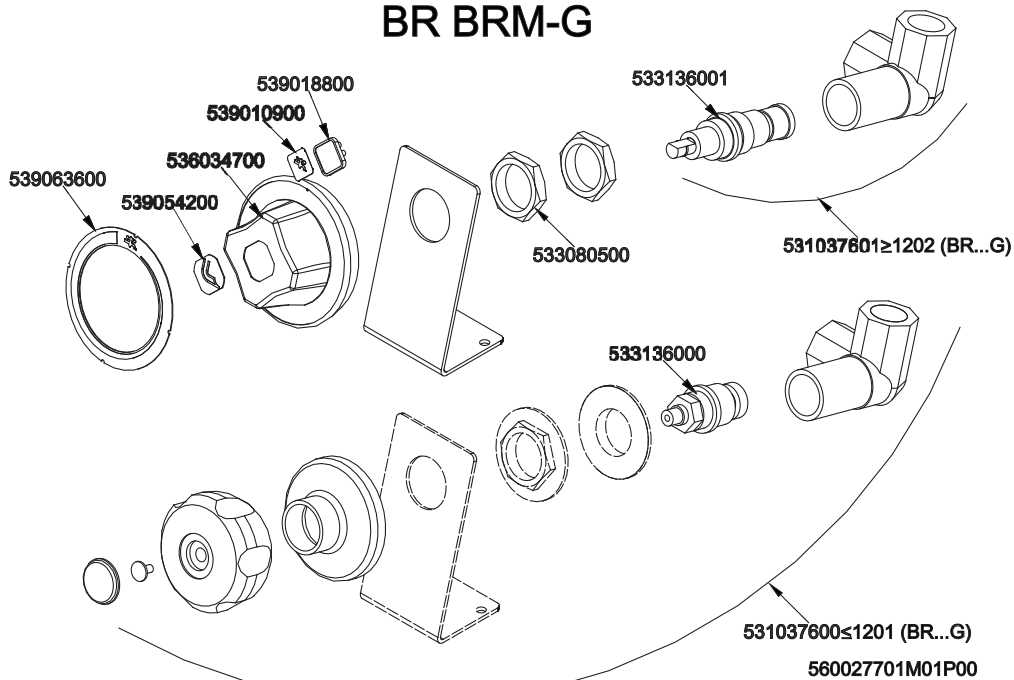

Page	Pos	Code	Description
001		532004100	FLUE GRID L=370 90LINE (RAF
001		531037701	BASKET SUPPORT GRID CP S.90
001		531042800	SEMISPHERE FILTER
001		544412900	BASKET HOLDER FOR DRAINAGE OF CP90
001		541319400	ASS.PIANO S90 CPA-98G
001		546006100	RUBBER TUBE §25INT.*§33EXT.*L=540
001		531018600	BALL VALVE 1"G M-F CPM-62G
001		533157400	FERMO PROLUNGA RUBINETTO 1"G Ø14
001		533157300	PROLUNGA RUB.1"G S90
001		533039900	PIPE HOLDER 1" G M D.24
001		533157500	RACC.A GOM.90° 1 G F.F.
001		544407400	LEFT SIDE PANEL 70 LINE
001		533040000	1"G F-F-F "T" FITTING
001		533149500	PROLUNGA 1 G M/M FE ZINC L100
001		541318700	ASS.CRUSC.LT CPA-78G CPA-98G
001		531017800	BURNER CPM-62G POLID.103.1515.0
001		537062800	CENTR.SENS.ACQUA E RAB.CP 230V
001		544407300	RIGHT SIDE PANEL 90 LINE
001		536005200	INOX LEG 2" 120-180 M10
001		537003800	TERMINAL BLOCK 3POLES 16A
002		533047900	BY PASS COCK §100 21S
002		533009400	BICONE 10S
002		533009500	NIPPLE FOR BICONE 10S
002		533053600	EUROSIT VALVE PLUG
002		539018900	INDEX FOR KNOB W/RED SIGN
002		533039100	BICONE §6
002		533018500	FITTING FOR BICONE D.6 M10*1
002		533010800	TUBE NUT D.10 M16*1,5
002		533039300	BICONE §10
002		531032100	GAS COCK 21S P.V.BY-PASS Ø100
002		537031901	RED WARNING LIGHT PCI 12V E FASTON
002		536034500	KNOB §77 4P. §08*6,5
002		539062800	RED STICKING DISK 72
002		539054200	STAMP Ø20,5 CR."L" LOTUS R.
002		537059500	
002		537059600	
002		537060300	IGNITION CONTROL BOX 2F. V30
002		533011500	PILOT BURNER 2 FLAMES 220
002		533045700	THERMOCOUPLE M9*1 500
002		533085200	SPACER FOR PILOT PLUG
002		533010400	BICONE D.6
002		537008300	ROUND PLUG §2,4- LONG ELECTRODE
002		533018600	PLUG FITTING
002		547002600	HIGH-VOLTAGE CABLE L=500
002		533010900	NUT M14*1 H.4
002		537015601	P.D.INTERR.IST.NERO FULMINE
002		537001701	P.D.INTERR.LUM.VERDE 0 1
002		533144900	MALE FITTING WATER INLET M16X1,5
002		531072600	RACC.PORTAINIETT.90°CANN.Ø101/2G
002		533020200	PILOT JETS 0160 FOR LPG §30
002		533020400	NOZZLE 0160 (NATURAL GAS) 51

Page	Pos	Code	Description
002		533044000	NOZZLE §195 CH12*14 M-CW4
002		533030900	NOZZLE §165 CH12X14 H-CW
002		533014300	NOZZLE §285 CH12*14
002		533056500	NOZZLE §325 CH12*14
003		544389300	CONTROP.73 SX APP. LT
003		531007600	DOOR HINGE
003		544182501	LEFT DOOR 73
003		533094200	S/S HANDLE FOR 70/90 SERIES
003		533035200	HANDLE SPACER
003		536000200	D.12 H.4 BUMPER
003		544389200	CONTROP.73 DX APP. LT
003		544182401	RIGHT DOOR 73
003		544182101	LEFT DOOR 74
003		544389500	INNER-DOOR OF LHD 74
003		544389400	CONTROP.74 DX APP. LT
003		544182001	RIGHT DOOR 74
003		544497000	PORTA 72 SX
003		544497100	CONTROP.72 SX APP. LT
003		544185101	RIGHT DOOR 74 CF
003		533107100	HANDLE SPACER OF CF-70
003		544185500	UPPER DOOR HINGE FOR COMPARTME CF70
003		531000900	MAGNET §22 KG.3 WITH DISK
003		544185201	INNER DOOR * 74DX
003		544185400	LOWER DOOR HINGE FOR COMPARTME CF70
003		544663900	LHD 74 DOOR FOR PCI
003		544663800	74 LHD OVEN INNER DOOR FOUR PCI
003		544662700	DOOR 74 DX PCI
003		544662600	CONTROP.74 DX APP. LT PCI
004		532004100	FLUE GRID L=370 90LINE (RAF
004		541132601	"V" GRID FOR CW-94
004		536014600	GRIP D.28*90*M10 CW
004		541132701	SPLASH SHIELD CW-94
004		541115901	UPPER PLATE CW-94
004		536014800	LAVASTONE
004		541132901	STONE SUPPORTING FRAME CW-94G
004		531044501	BURNER CW-G 90 LINE
004		533100900	AIR ADJUSTMENT BUSHING D22 EST.H38
004		541058700	BURNER COUPLING BUSHING CW-G
004		544407400	LEFT SIDE PANEL 70 LINE
004		544023901	SPATTLE FOR FRY-TOP
004		541114000	DRAINER DRAWER CW-G 90LINE
004		541108400	CONTROL PANEL CW-74G
004		544407300	RIGHT SIDE PANEL 90 LINE
004		536005200	INOX LEG 2" 120-180 M10
005		533010800	TUBE NUT D.10 M16*1,5
005		533155600	PERNO PER SENSORE ACQUA
005		536039100	GUIDA PER SENSORE ACQUA
005		536039000	GUARNIZ.O-RING 12,42X1,78 SILIC.
005		536039200	DISTANZIALE PER SENSORE ACQUA
005		533039300	BICONE §10
005		533159400	RACC.UN.2 U.ELETTROV.ACQUA CP

Page	Pos	Code	Description
005		533144500	FITTING FOR WATER INPUT 3/4G
005		531037500	RACCORD CA.H2O 1/2G CAN.D10
005		533144900	MALE FITTING WATER INLET M16X1,5
005		533048700	NUT 1/2G ZN
005		533048800	GASKET §30*§21*2 FIBRE
005		533147000	BICONE FITTING 3/4G ZN
005		533009500	NIPPLE FOR BICONE 10S
005		533075200	CODICE IN ELABORAZIONE
005		533075300	CODICE IN ELABORAZIONE
005		533024400	HEXAGONAL NUT 1/2G TUBE D.10
005		537062900	ELETTROV.A.3/4GM-2O10JG 230V RPV
005		537063800	COIL ELECTROV.G.1/2GF 230V
005		533065700	FITTING FOR WATER INPUT 1/2G
005		533148100	RACC.A GOM.90° 1/2G F.M16X1,5M. (S
005		537063000	ELETTROV.G.1/2GF-1/2GF 230V
005		539010900	ADHESIVE LABEL FOR DRAIN COCK
005		533136001	SCREW TAP WATER LOAD FOR CP S70/90
005		539012000	ADHESIVE LABEL FOR DRAIN COCK USA
005		539018800	BLANK INDEX FOR KNOB
005		539063600	ADHESIVE DISK 72 FOR DRAIN COCK
005		539063700	ADHESIVE DISK 72 FOR DRAIN COCK USA
005		536034700	KNOB §77 4P. §08*6,5 F§30
005		539054200	STAMP O20,5 CR."L" LOTUS R.
005		531037601	TAP FOR WATER 90°DX CP
005		533080500	CODICE IN ELABORAZIONE
005		533136000	SCREW TAP WATER LOAD FOR CP S70/90
005		531037600	TAP FOR WATER LOADING 1/2"GF CP 90
006		533010800	TUBE NUT D.10 M16*1,5
006		533155600	PERNO PER SENSORE ACQUA
006		536039100	GUIDA PER SENSORE ACQUA
006		536039000	GUARNIZ.O-RING 12,42X1,78 SILIC.
006		536039200	DISTANZIALE PER SENSORE ACQUA
006		533039300	BICONE §10
006		533159400	RACC.UN.2 U.ELETTROV.ACQUA CP
006		533144500	FITTING FOR WATER INPUT 3/4G
006		531037500	RACCORD CA.H2O 1/2G CAN.D10
006		533144900	MALE FITTING WATER INLET M16X1,5
006		533048700	NUT 1/2G ZN
006		533048800	GASKET §30*§21*2 FIBRE
006		533147000	BICONE FITTING 3/4G ZN
006		533009500	NIPPLE FOR BICONE 10S
006		533024400	HEXAGONAL NUT 1/2G TUBE D.10
006		537062900	ELETTROV.A.3/4GM-2Ø10JG 230V RPV
006		537063800	COIL ELECTROV.G.1/2GF 230V
006		533065700	FITTING FOR WATER INPUT 1/2G
006		533148100	RACC.A GOM.90° 1/2G F.M16X1,5M. (S
006		537063000	ELETTROV.G.1/2GF-1/2GF 230V
006		539010900	ADHESIVE LABEL FOR DRAIN COCK
006		533136001	SCREW TAP WATER LOAD FOR CP S70/90
006		539012000	ADHESIVE LABEL FOR DRAIN COCK USA
006		539018800	BLANK INDEX FOR KNOB

Page	Pos	Code	Description
006		539063600	ADHESIVE DISK 72 FOR DRAIN COCK
006		539063700	ADHESIVE DISK 72 FOR DRAIN COCK USA
006		536034700	KNOB §77 4P. §08*6,5 F§30
006		539054200	STAMP Ø20,5 CR."L" LOTUS R.
006		531037601	TAP FOR WATER 90°DX CP
006		533136000	SCREW TAP WATER LOAD FOR CP S70/90
006		531037600	TAP FOR WATER LOADING 1/2"GF CP 90