

## CME256 or CME506 or CME656 or CME806 Service Parts

This parts list contains service part information for 6 basic models, plus 4 different electrical configurations.

The complete model number will be needed to identify the correct part.

Unique parts include: electrical, refrigeration and some water system items.

Electrical Codes are located at the end of the model number (voltage/hertz/phase):

- -1 is 115/60/1
- -32 is 208-230/60/1
- -3 is 208-230/60/3
- -6 is 250/50/1

Electrical Components Common to All Machines:

- Inlet water valve
- Water sensor
- Discharge line sensor
- Controller
- Bin controls
- Water level sensor
- Hi pressure cut out

Unique Electrical Components

- Compressor and related starting components
- Contactor (single / three phase)
- Fan motor
- Water pump
- Transformer

### Table of Contents

Cabinet . . . . .	page 2
Interior Structure & Controls . . . . .	page 3
CME256 Air Cooled Refrigeration . . . . .	page 4
CME506 Air Cooled Refrigeration . . . . .	page 5
CME656 Air Cooled Refrigeration . . . . .	page 6
CME806 Air Cooled Refrigeration . . . . .	page 7
Water System Components . . . . .	page 8
CME256 Water Cooled Refrigeration . . . . .	page 9
CME506 Water Cooled Refrigeration . . . . .	page 10
CME656 Water Cooled Refrigeration . . . . .	page 11
CME806 Water Cooled Refrigeration . . . . .	Page 12
Compressors & Electrical Components . . . . .	page 13
HTB555 Ice Storage Bin . . . . .	page 14
Wiring Diagrams . . . . .	page 15

## CME256 or CME506 or CME656 or CME806 Service Parts

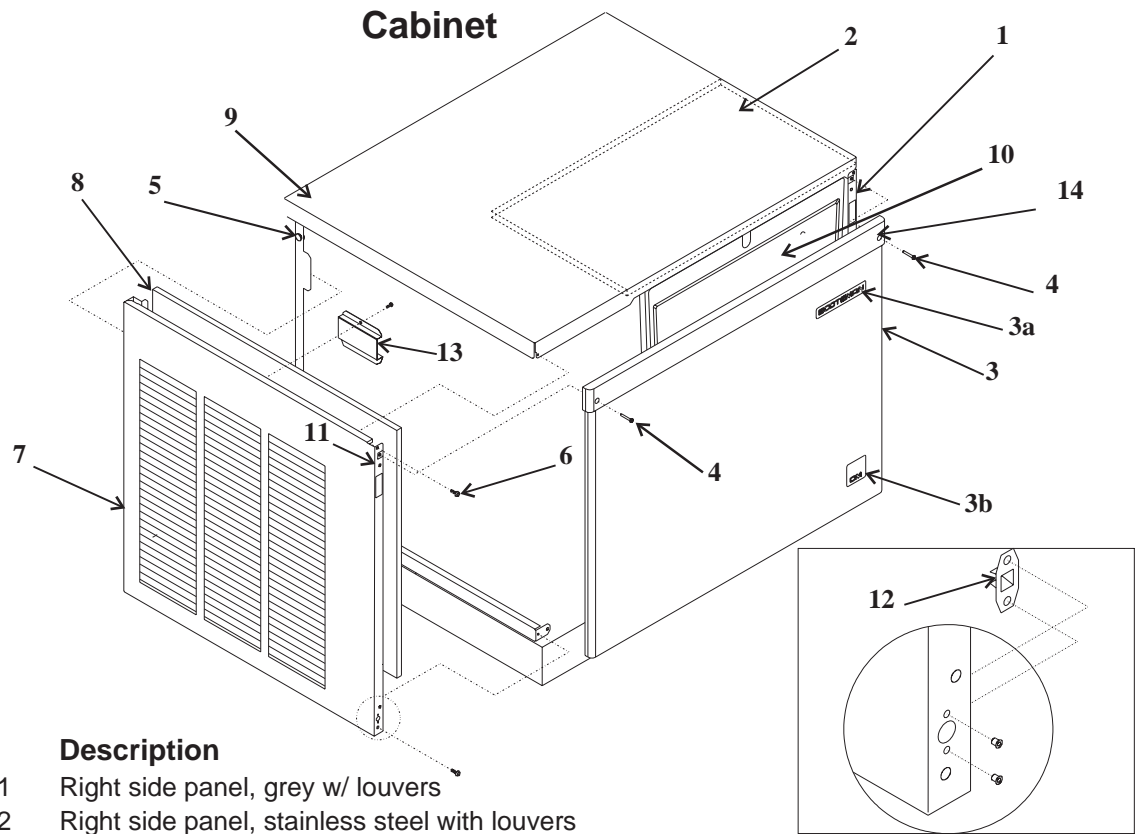

Item Number	Part Number	Description	
1	A35963-021	Right side panel, grey w/ louvers	
	A35963-022	Right side panel, stainless steel with louvers	
	A37071-021	Right side panel, grey enamel without louvers (water cooled only)	
	A37071-022	Right side panel, stainless steel without louvers (water cooled only)	
	2	02-3659-01	Top insulation
3	02-3797-21	<b>C model Front panel kit, gray plastic</b> , includes trim strip & emblems	
	03-1733-01	Strike (for C model panel, SS and plastic)	
	A37167-001	Front panel kit, gray plastic, includes item 10a (for A models)	
	A37488-001	<b>C model Front panel kit, stainless steel</b> , includes trim strip & emblems	
3a	A35964-002	Front panel kit, stainless steel (for A models)	
	15-0711-02	Emblem for ss panel (Scotsman); 03-0271-00 is the speed nut for emblem	
3b	15-0792-01	Emblem for C model front panel, (CM <sup>3</sup> )	
4	03-1735-01	Screw for trim strip (for C model)	
	03-1404-12	Sheet metal screw for plastic front panel (for A Model)	
	03-1419-22	Sheet metal screw for ss front panel	
5	02-1875-03	Panel bumper/hole plug	
	6	03-1531-01	Sheet metal screw
		03-1531-01	Sheet metal screw
	7	A35962-021	Left side panel, grey enamel with louvers
A35962-022		Left side panel, stainless steel with louvers	
A37070-021		Left side panel, grey enamel without louvers (water cooled only)	
A37070-022		Left side panel, stainless steel without louvers (water cooled only)	
8	02-3485-01	Air filter, air cooled only	
	02-3485-01	Air filter, air cooled only	
9	A35965-001	Top panel, grey enamel, order item 2 also	
	A35965-002	Top panel, stainless steel, order item 2 also	
10a	02-3663-01	Evaporator cover, use began Feb. 1997.	
	02-3810-01	Insulation	
10b	A36960-001	Evaporator cover, only used with A model SS front panels.	
11	03-1423-06	Speed nut for panel screws	
12	03-1733-02	Catch	
13	A37326-001	Filter bracket	
14	02-3794-01	Trim strip.      03-1731-02 is the push nut for trim strip	

# CME256 or CME506 or CME656 or CME806 Service Parts

## Interior Structure & Controls

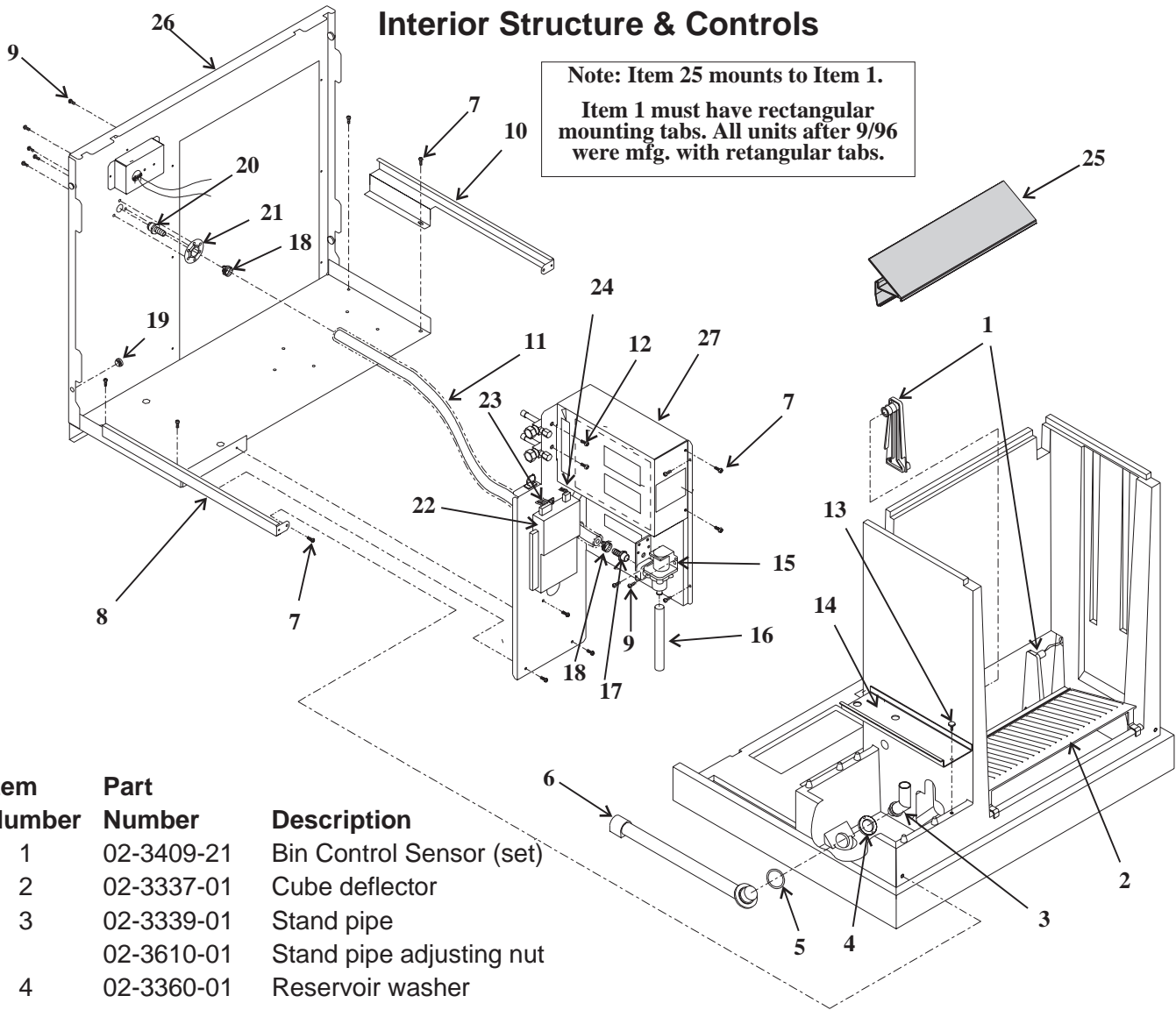

Item Number	Part Number	Description	
1	02-3409-21	Bin Control Sensor (set)	
2	02-3337-01	Cube deflector	
3	02-3339-01	Stand pipe	
	02-3610-01	Stand pipe adjusting nut	
4	02-3360-01	Reservoir washer	
5	13-0617-56	O-ring	
6	02-3338-01	Drain tube & fittings	
7	03-1404-18	Screw	
8	A36298-001	Left side channel	
9	03-1531-01	Screw	
10	A36297-001	Right side channel	
11	13-0906-01	Plastic inlet water hose, 21" req. order 2 units - not used after Sept. 1996	
12	03-1645-01	Screw	
13	03-1691-01	Nylon screw	
14	02-3340-01	Reservoir cover	
15	12-2548-01	Inlet water valve	
16	13-0674-02	Tubing, 9" req., order 1 unit	
17	02-3443-01	Water fitting for hose	
	16-1020-01	Water fitting for copper	
18	02-0179-05	Clamp	
19	13-0903-01	Bumper for side panels	
20	16-0997-01	Inlet water fitting for hose	
	16-1019-01	Inlet water fitting for copper	
	21	16-0701-07	Mounting flange
	22	12-2543-21	System controller
	23	12-2644-21	Low voltage harness
	24	12-2476-21	Hi volt. harness for w/o fan control
		12-2678-01	Hi volt. harness for 50 Hz models
	25	02-3657-01	Cascading shield, used on CME806; + CME656 and CME506 after 2/97
	26	A36460-001	Back panel assy
	27	A35959-001	Hi voltage box cover

### CME806 Air Cooled Refrigeration

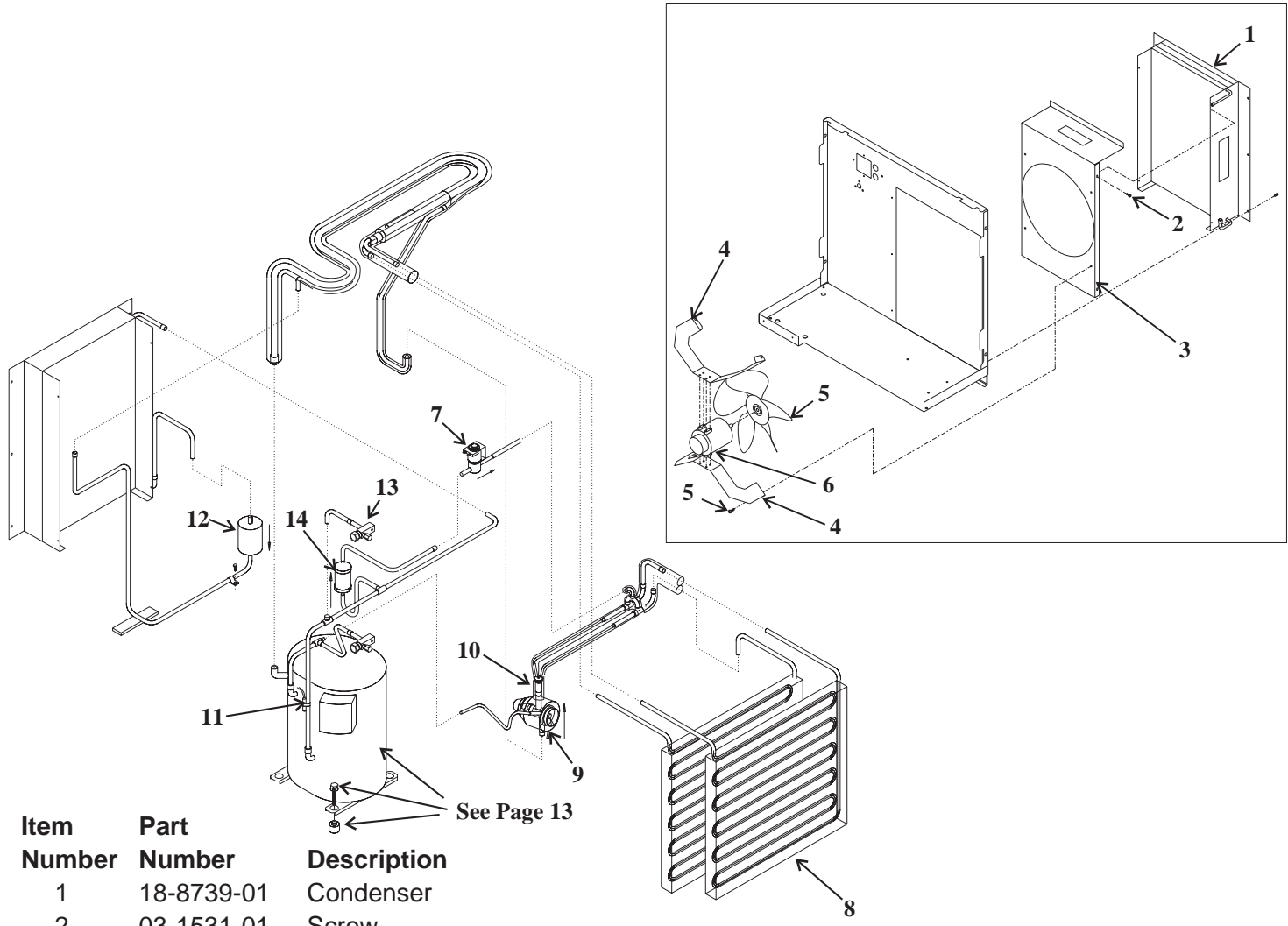

Item Number	Part Number	Description
1	18-8739-01	Condenser
2	03-1531-01	Screw
3	A35967-001	Shroud
4	A36668-001	Motor bracket
5	18-8503-01	Fan blade
6	<b>18-8829-01</b>	<b>Fan motor for 60 Hz.</b>
	<b>18-8829-02</b>	<b>Fan motor for 50 Hz.</b>
7	12-2471-24	Hot gas valve complete w/coil
	12-2719-23	Hot gas valve coil only
	12-2733-30	Hot gas valve repair kit (no body, no coil)
8	A36734-020	Evaporator
9	16-1065-21	TXV
	02-3396-01	Insulation for TXV
10	16-0843-02	Distributor and tubes
11	02-3410-21	Temperature sensor, includes water temp sensor & clip
	03-1711-01	Clip
12	03-3319-02	Dryer
13	16-0832-21	Access valve
13a	16-0832-03	Port cap
13b	16-0832-02	Stem cap
14	16-1063-01	Hot gas valve strainer

# CME256 or CME506 or CME656 or CME806 Service Parts

## Water System Components

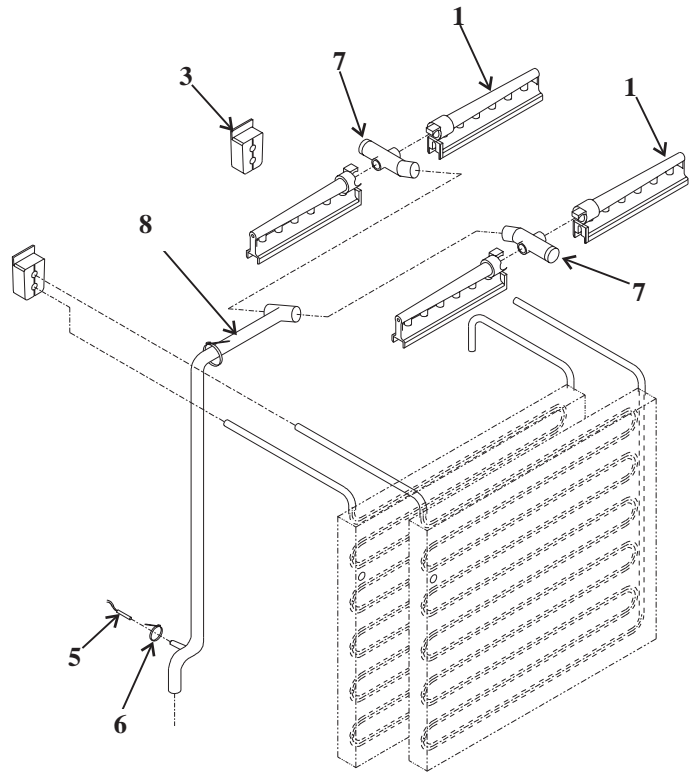
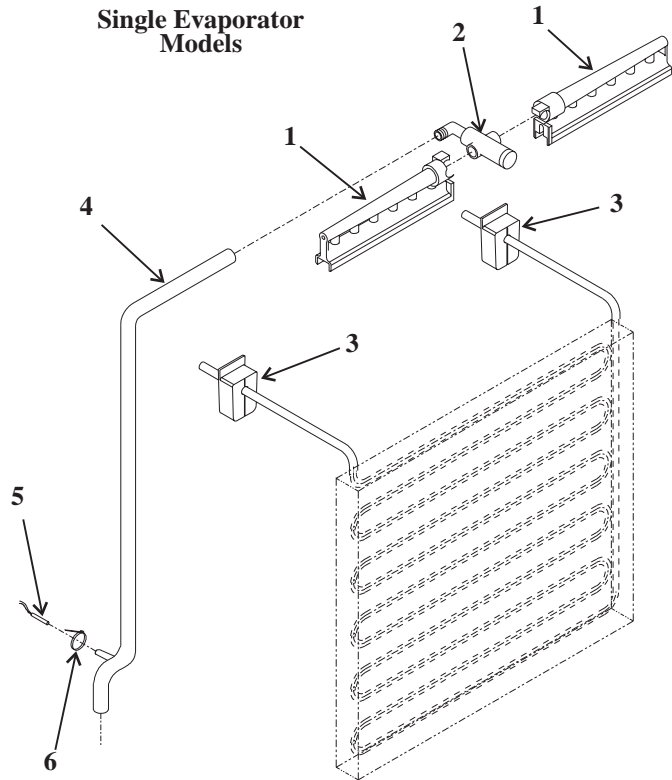

Item Number	Part Number	Description
1	02-2527-01	Water distributor
2	A30926-001	Distributor manifold
3	13-0898-02	Tubing grommet
4	02-3361-01	Water discharge tube for <b>single</b> evaporator models
5	02-3410-21	Water temperature sensor includes disch. temp. sensor
6	no number	Cable tie
7	02-3405-01	Inlet Tee
8	13-0840-01	Rubber plug
8	02-3336-01	Water distributor tube for <b>double</b> evaporator models
9	02-3383-01	Float stem, <b>1 evaporator model*</b>
	02-3383-02	Float stem, <b>2 evaporator model*</b>
10	02-3707-21	Float (water level) sensor
11	02-3388-04	Front pump bracket for 12-2586 type pump
12	02-3388-05	Rear pump bracket for 12-2586 type pump
13	12-2506-01	Harness
14	02-3341-01	Float
15	12-2586-21	<b>CME256 pump</b>
	12-2586-22	<b>CME506-1 pump (115/60 Hz)</b>
	12-2586-23	<b>CME656 or CME506-6 or CME806 (203-230/50-60 Hz) pump</b>

\* Not adjustable after 2/97. Then 1 evap model white, 2 evap. model grey.

### CME806 Water Cooled Refrigeration

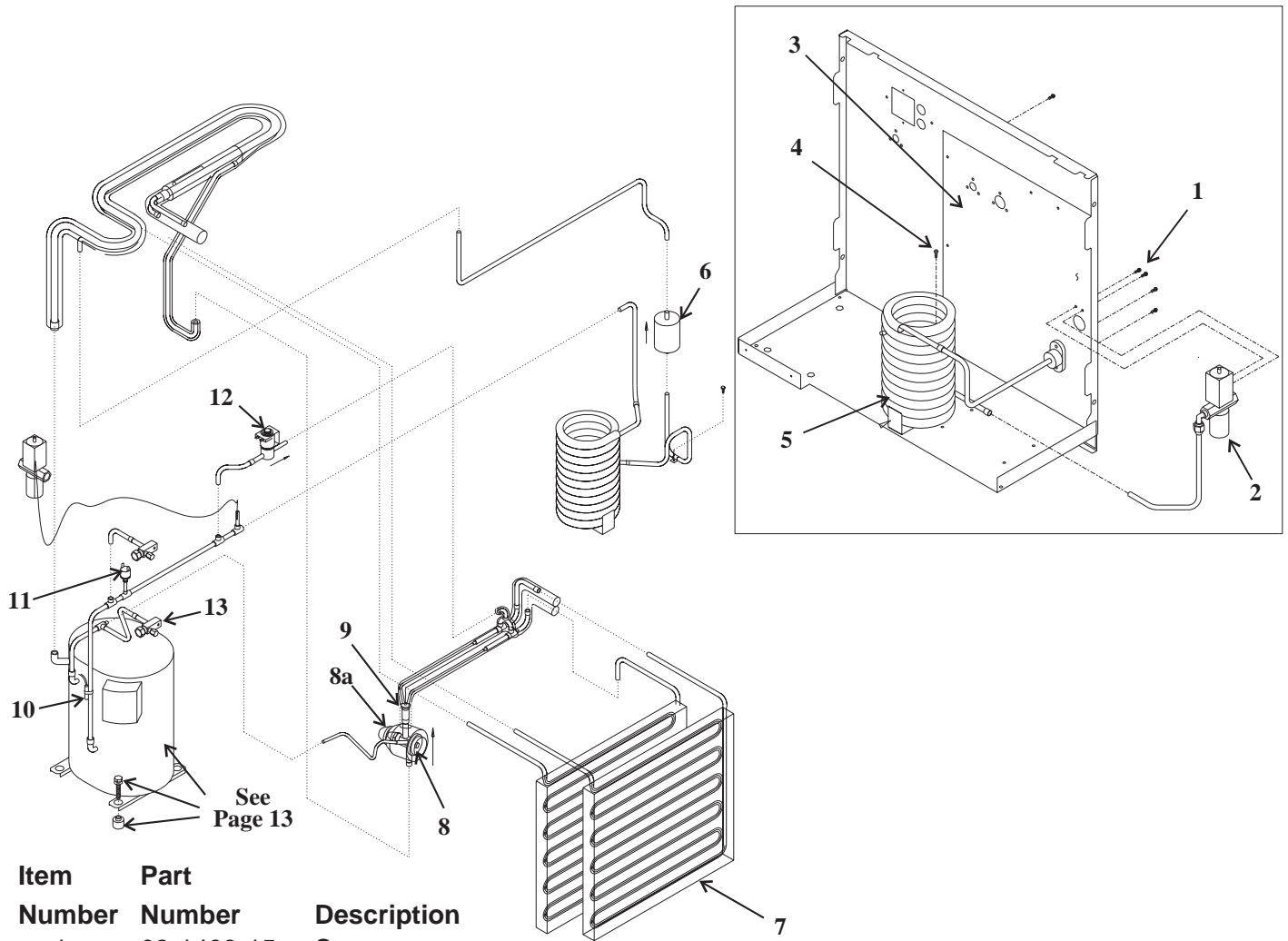

Item Number	Part Number	Description
1	03-1403-15	Screw
2	11-0478-21	Water regulating valve
3	A36440-001	Back cover
4	03-1645-01	Screw
5	18-6900-21	Condenser
6	02-3319-02	Dryer
7	A36734-020	Evaporator
8	16-1065-21	TXV 1/2 ton
8a	02-3396-01	Insulation for TXV
9	16-0843-02	Distributor and tubes
10	02-3410-21	Hi temperature sensor, includes water temperature sensor
	03-1711-01	Clip for sensor mounting
11	11-0501-21	Hi pressure cut out
12	12-2471-24	Hot gas valve complete w/coil
	12-2719-23	Hot gas valve coil only
	12-2733-30	Hot gas valve repair kit, no coil, no body
13	16-0832-21	Access valve
13a	16-0832-03	Port cap
14	16-1063-01	Hot gas valve strainer, not shown



# CME256 or CME506 or CME656 or CME806 Service Parts

## Compressors and Electrical Components

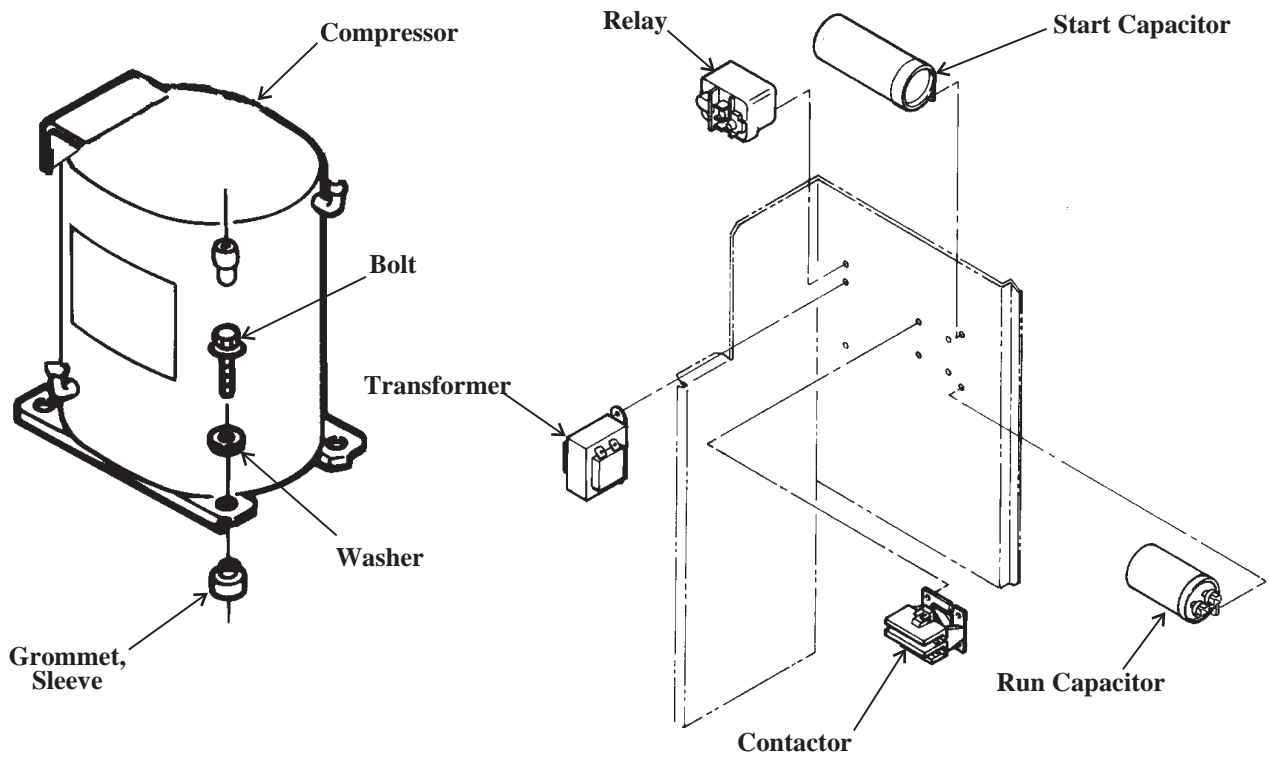

Model	CME256	CME506		CME656			CME806	
Voltage/Hz	115/60	115/60	230/50	208-230/60	208-230/60	230/50	208-230/60	230/50
Phase	Single	Single	Single	Single	Three	Single	Single	Single
Compressor	18-8720-21*	18-8721-21*	18-8721-22	18-8813-23*	18-8813-25	18-8813-27	18-8749-22*	18-8749-27
Start Relay	18-1903-44	18-1903-50	18-1903-29	18-1903-33	not used	18-1903-29	18-1903-46	18-1903-33
Start Capacitor	18-1901-49	18-1901-03	18-1901-43	18-1901-15	not used	18-1901-52	18-1901-48	18-1901-48
Run Capacitor	18-1902-52	18-1902-45	18-1902-30	18-1902-53	not used	18-1902-53	18-1902-55	18-1902-55
Overload	18-5700-50	18-8711-50	18-8721-50	internal	internal	internal	internal	internal
Mounting Bolt	03-1405-20	03-1405-20	03-1405-20	03-1405-20	03-1405-20	03-1405-20	03-1405-20	03-1405-20
Sleeve	18-2200-27	18-2200-27	18-2200-27	18-2200-27	18-2200-27	18-2200-27	18-2200-27	18-2200-27
Washer	03-1407-07	03-1407-07	03-1407-07	03-1407-07	03-1407-07	03-1407-07	03-1407-07	03-1407-07
Grommet	18-2200-28	18-2200-28	18-2200-28	18-2200-28	18-2200-28	18-2200-28	18-2200-28	18-2200-28
Contactora	12-2469-01	12-2469-01	12-2469-01	12-2469-01	12-2533-01	12-2469-01	12-2469-01	12-2469-01
Transformer	A37231-001	A37231-001	12-2617-21	12-2617-21	12-2617-21	12-2617-21	12-2617-21	12-2617-21

\* Includes start relay, start capacitor, and run capacitor. All compressors include a drier. .

-6B Models	Transformer	Hi Voltage Harness	Fuse	Fuse Block	Relay	Relay Bracket
CME506 or CME656 -6B or CME806 -6B	12-2639-02	12-2678-21	12-2686-01	12-2687-01	12-2679-01	12-2680-01

HTB555 Ice Storage Bin

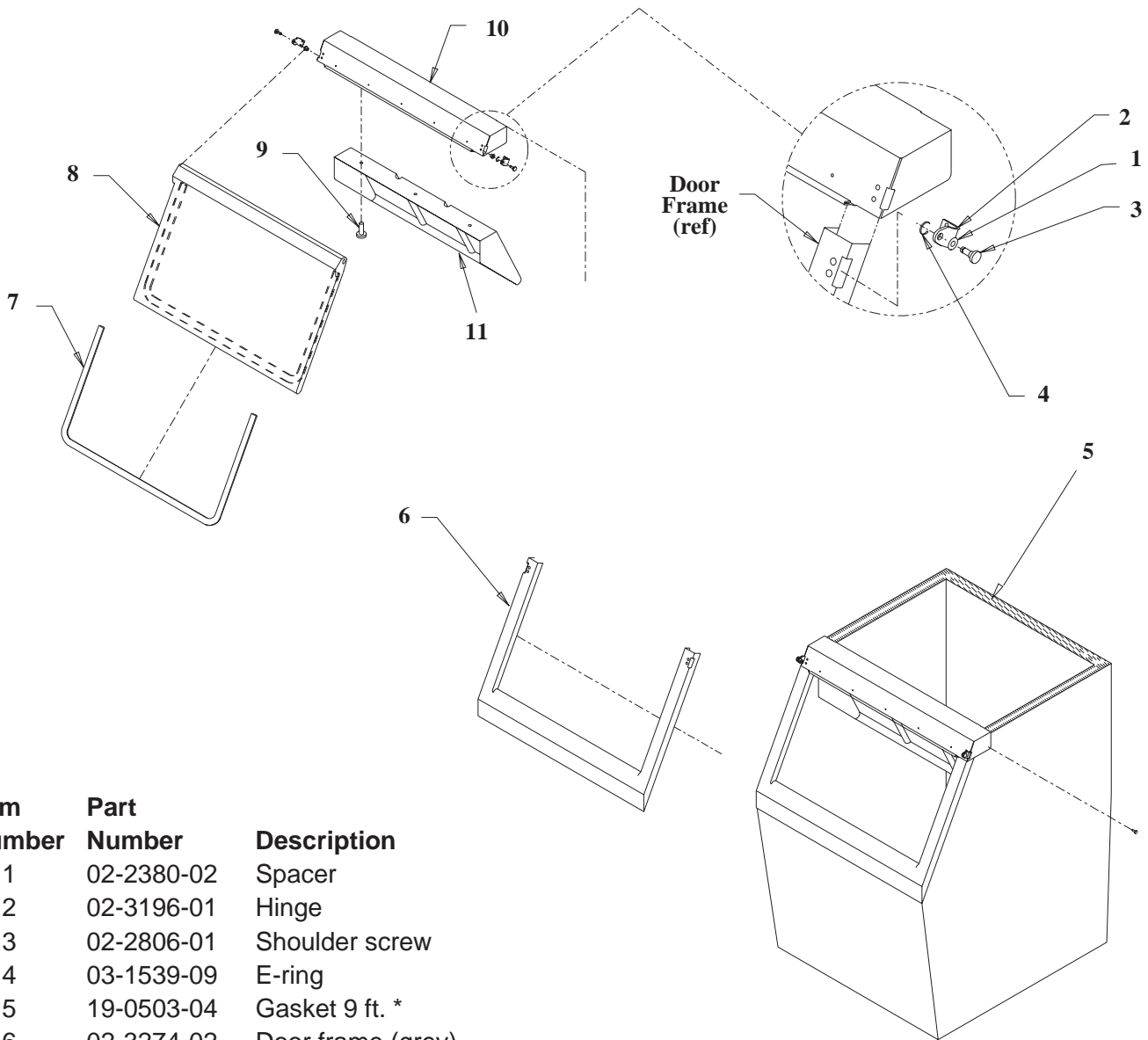

Item Number	Part Number	Description
1	02-2380-02	Spacer
2	02-3196-01	Hinge
3	02-2806-01	Shoulder screw
4	03-1539-09	E-ring
5	19-0503-04	Gasket 9 ft. *
6	02-3274-02	Door frame (grey)
7	13-0909-01	Door gasket - 58" *
8	A36481-022	Door, grey, includes #7.
9	03-0727-11	Thumb screw
10	A35637-001	Canopy
11	A35640-001	Baffle
12	02-2809-02	Drain top
13	13-0617-09	O-ring
14	02-3108-01	Drain bottom

Not shown

03-1404-07	Screw for drain bottom
05-0586-01	Drain elbow
02-0540-00	Scoop
KLP2E	Enamel leg kit

\* Order gasket by the foot.

