

CMS1002R SERVICE PARTS

This parts list contains the parts for the CMS1002R. The model number of the machine is located on the ice machine in two places: on the back panel, and behind the front panel below the control box.

Check the model number to be certain of obtaining the correct parts.

TABLE OF CONTENTS

Cabinet	Page 2
Refrigeration System	Page 3
Water System	Page 4
Control Box	Page 5
Remote Condenser	Page 6
Ice Storage Bin	Page 7
Wiring Diagrams	Page 8

CMS1002R SERVICE PARTS

CABINET

ITEM NUMBER	PART NUMBER	DESCRIPTION	ITEM NUMBER	PART NUMBER	DESCRIPTION
1	A32159-002	Top Panel, SS	15	A34038-001	Service Panel, painted
	A32159-001	Top Panel, painted	16	03-1404-12	Screw
2	02-2887-02	Right Liner	17	A32435-002	Left Side Panel, SS
3	A35453-002	Right Side Panel, SS		A32435-001	Left Side Panel, painted
	A35453-001	Right side panel, painted	18	A34861-001	Base Assembly
4	A32470-001	Brace	19	A32454-001	Retainer
5	A32469-001	Upper cabinet brace	20	A34826-002	Back Panel, SS
6	03-1531-01	Screw		A34826-001	Back Panel, painted
7	A32160-002	Front Panel SS	21	A32452-003	Right Back Panel, SS
	A32160-001	Front Panel, painted		A32452-001	Right Back Panel, painted
	15-0411-00	Strike for front panel	22	02-2888-02	Back Liner
	03-1406-04	Nut for strike	23	15-0711-01	Scotsman emblem
8	A32549-002	Flange retainer		03-0271-00	Clip for emblem
9	A32587-001	Upper Evap. Brace	24	A32464-001	Stand off for curtain
10	A32467-001	Lower Evap. Brace			
11	02-2885-02	Left liner			
12	A31461-001	Tube bracket			
	A31462-001	Tube bracket			
13	A34908-021	Transducer			
14	02-0836-00	Catch			
15	A34038-002	Service Panel, SS			

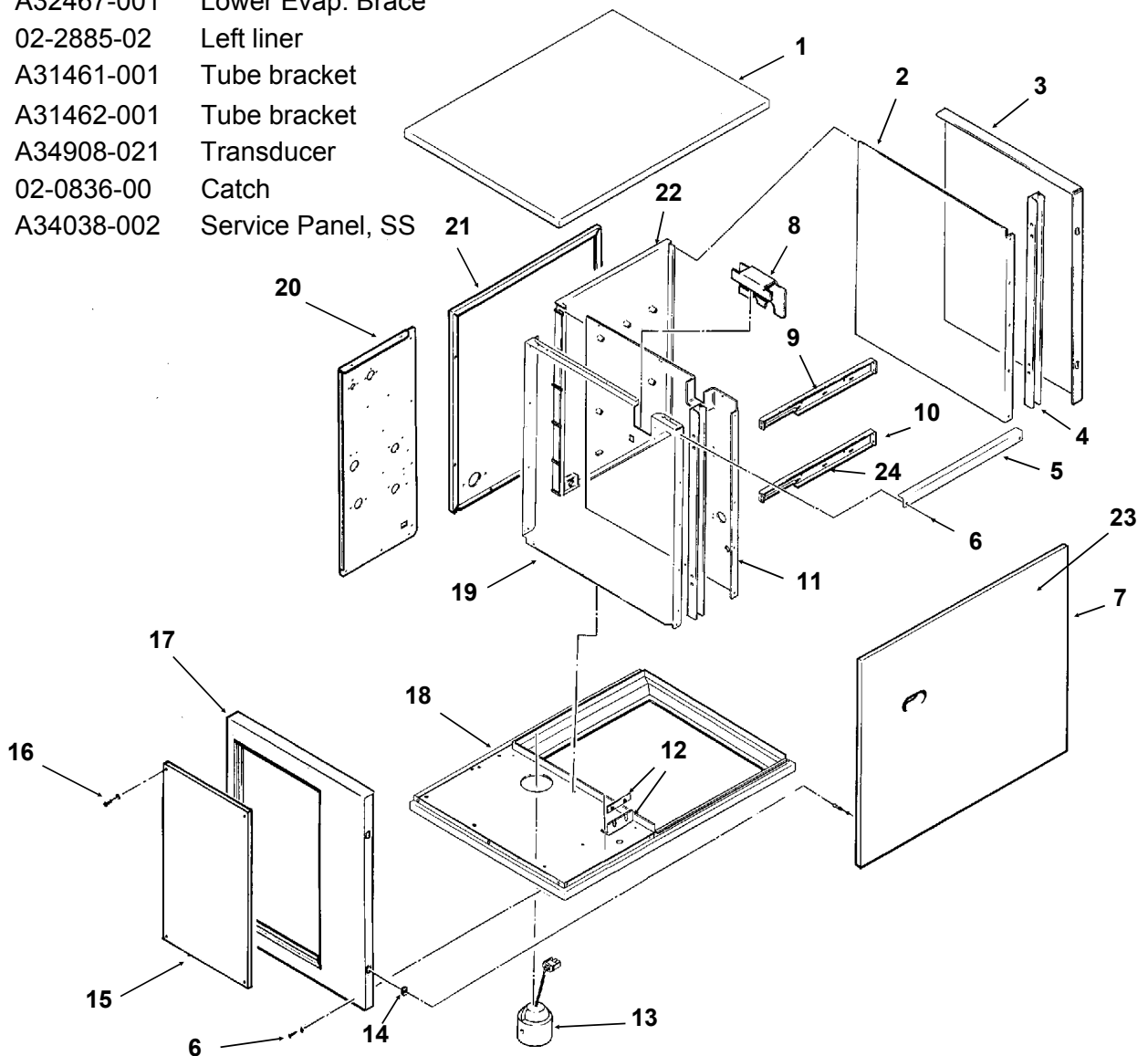

CMS1002R SERVICE PARTS

REFRIGERATION SYSTEM

ITEM NUMBER	PART NUMBER	DESCRIPTION	ITEM NUMBER	PART NUMBER	DESCRIPTION
1	16-0876-01	Evap. inlet assembly	8	12-2274-01	Liquid line valve
2	A30296-020	Evaporator	9	02-3319-01	Filter dryer
3	11-0446-24	Hi pressure control switch	10	16-0761-01	Receiver
4	16-0560-00	Valve core	11	16-0850-03	3/8" male coupling
	16-0563-00	Cap	12	16-0850-01	1/2" male coupling
5	16-0801-21	Accumulator	13	11-0422-23	Head press. control valve
6	11-0467-22	Pump down control switch	14	12-2428-22	Hot gas valve
7	18-8862-21	Compressor 208-230/60/1	15	12-2300-02	Hi temp cut out
	18-8862-22	Compressor 203-230/60/3	16	16-0816-22	Thermo expansion valve
				02-2920-01	Insulation for TXV (half)
Replacement compressors include the crankcase heater.			17	16-0792-02	Refrigerant distributor
	12-2308-01	Crankcase heater			
	18-2200-27	Sleeve			
	18-2200-28	Grommet			
	03-1405-20	Screw			

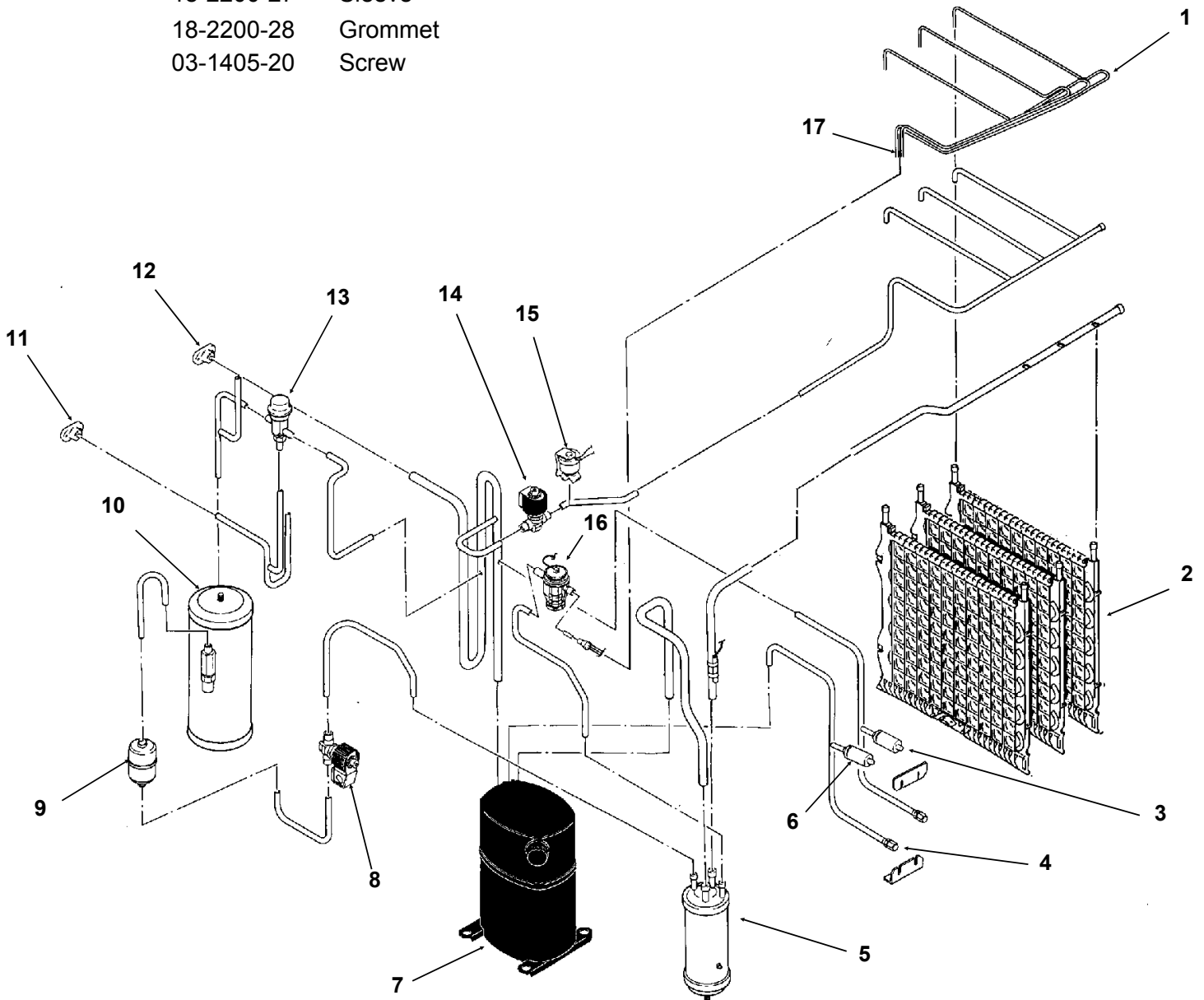

CMS1002R SERVICE PARTS

WATER SYSTEM

ITEM NUMBER	PART NUMBER	DESCRIPTION	ITEM NUMBER	PART NUMBER	DESCRIPTION
1	02-2527-01	Water Distributor Tube	8	A30296-020	Evaporator
2	02-2521-01	Water Manifold, long	9	02-2890-02	Evaporator Cover
3	13-0617-48	O-Ring	10	A35861-001	Reservoir
4	A29703-001	Water Manifold, short	11	12-1646-11	Inlet Water Valve
5	02-2895-01	Water Restrictor	12	13-0674-01	Hose (8" needed)
6	13-0674-07	Tube (need 30")	13	12-2419-62	Water Pump
7	02-3094-01	Hose clamp	14	A32462-001	Housing, pump
			15	A32551-001	Bracket, pump
			16	03-0727-00	Thumb screw
			17	03-1406-05	Nut for top of pump
			18	03-1407-03	Washer for top of pump
			19	13-0674-07	Drain hose (16.5" needed)
			20	02-3094-01	Hose clamp
			21	A32282-003	Drain
			22	03-1394-01	Pal nut
			23	16-0791-01	Coupling (half union)
			24	16-0794-01	Adaptor
			25	16-0631-02	Connector, female
			26	16-0162-00	Strainer
			27	A32474-001	Inlet Tube
			28	13-0796-01	Reservoir Drain Cap

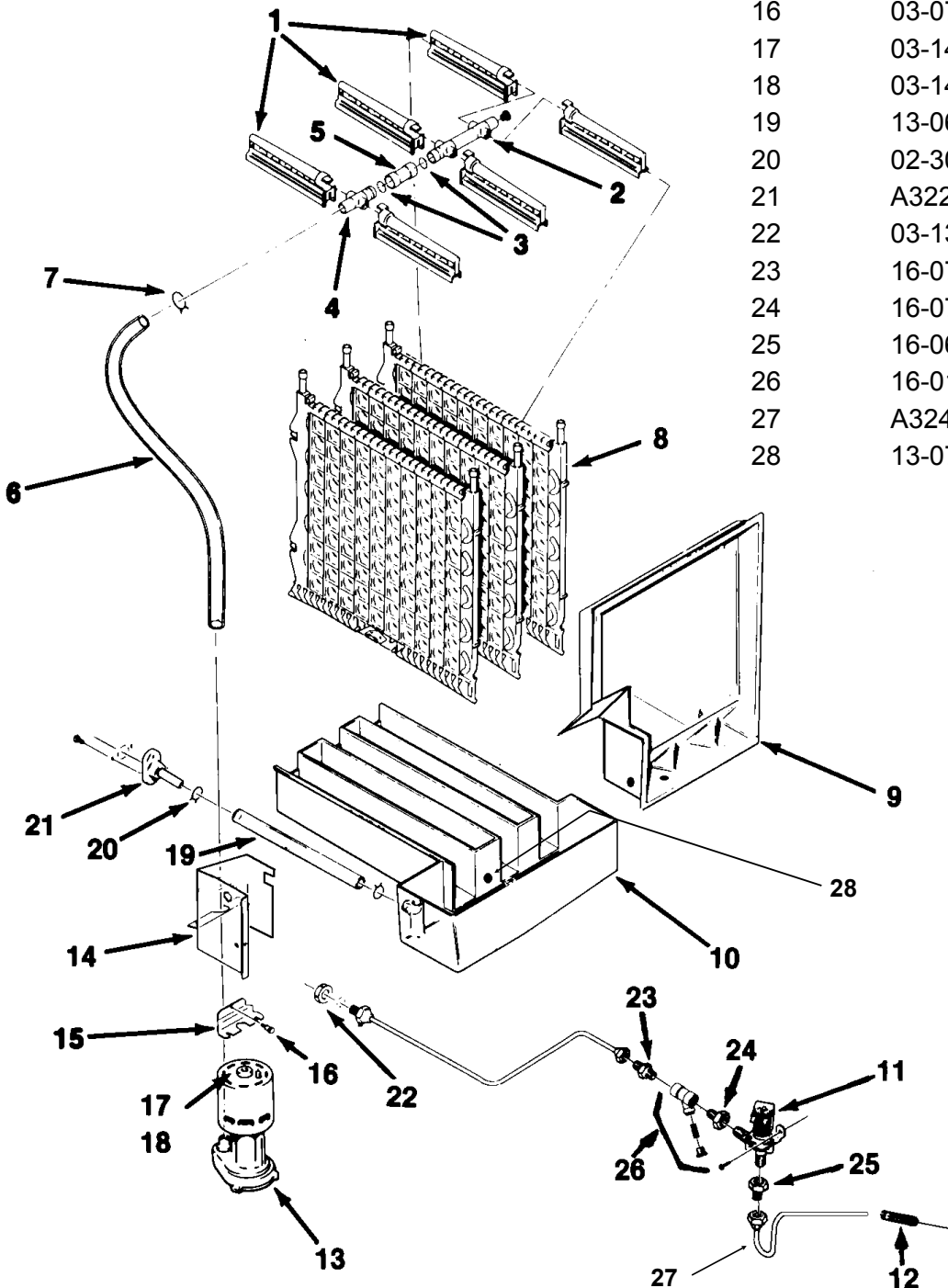

CMS1002R SERVICE PARTS CONTROL BOX

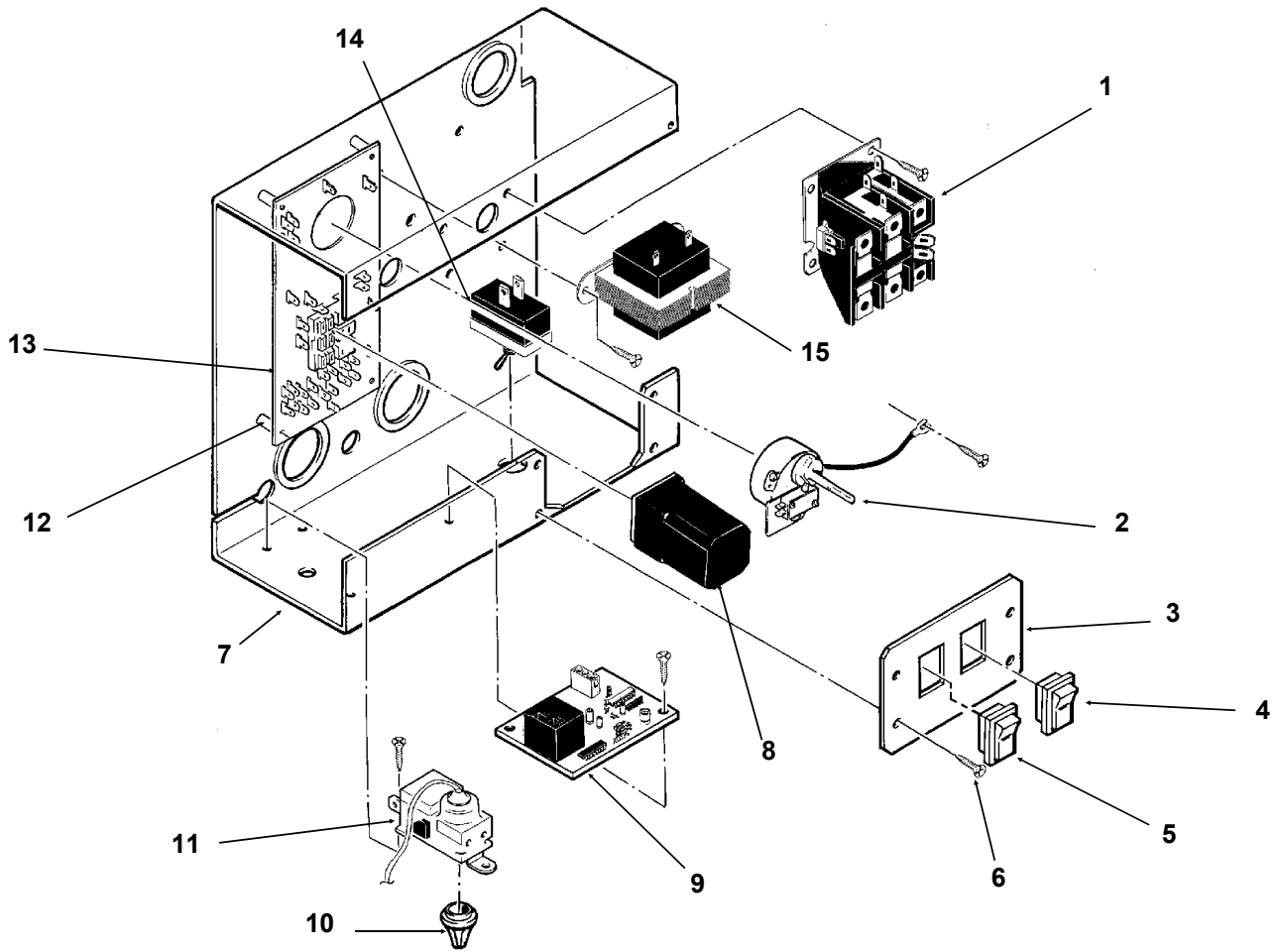

ITEM NUMBER	PART NUMBER	DESCRIPTION
1	12-0739-02	Contactora 3 phase
	12-2469-02	Contactora single phase
2	12-2317-22	Timer and microswitch
3	02-3173-01	Cover plate
4	12-2414-01	ON/OFF/WASH switch
5	12-2411-01	Bin ice level switch
	12-2402-01	Wire harness, bin level switch to sonar board
6	03-1638-03	Screw
7	no number	Control box
8	12-1879-03	Relay
9	12-2376-21	Bin level control board
10	no number	Knobl, part of item 11
11	11-0436-21	Cube size control, includes knob
12	02-2242-02	Stand off
13	12-1912-01	Circuit board
14	12-0426-01	Compressor on off switch
15	12-2285-22	Transformer

Not Shown:

16	A34845-001	Control Box Cover
17	17-1961-01	Label for control box cover
18	18-1903-46	Potential Relay
19	18-1902-27	Run Capacitor
	A34314-001	Run Cap. Bracket
20	18-1901-48	Start Capacitor
	18-8702-01	Start Capacitor Cap

CMS1002R SERVICE PARTS

SCOTSMAN REMOTE CONDENSER

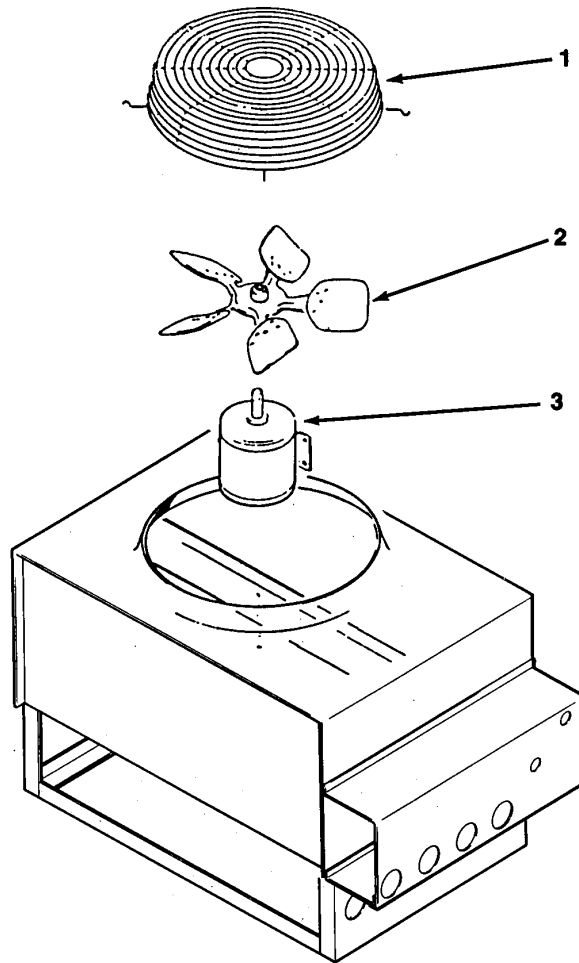

RC1052

ITEM NUMBER	PART NUMBER	DESCRIPTION
1	02-2618-01	Fan Guard
2	18-6304-01	Fan Blade
3	18-5301-01	Fan Motor

For Precharged Line set:

4	16-1057-01	Female coupling (3/8")
5	16-1057-02	Female coupling (1/2")

CMS1002R SERVICE PARTS

ICE STORAGE BIN SERVICE PARTS

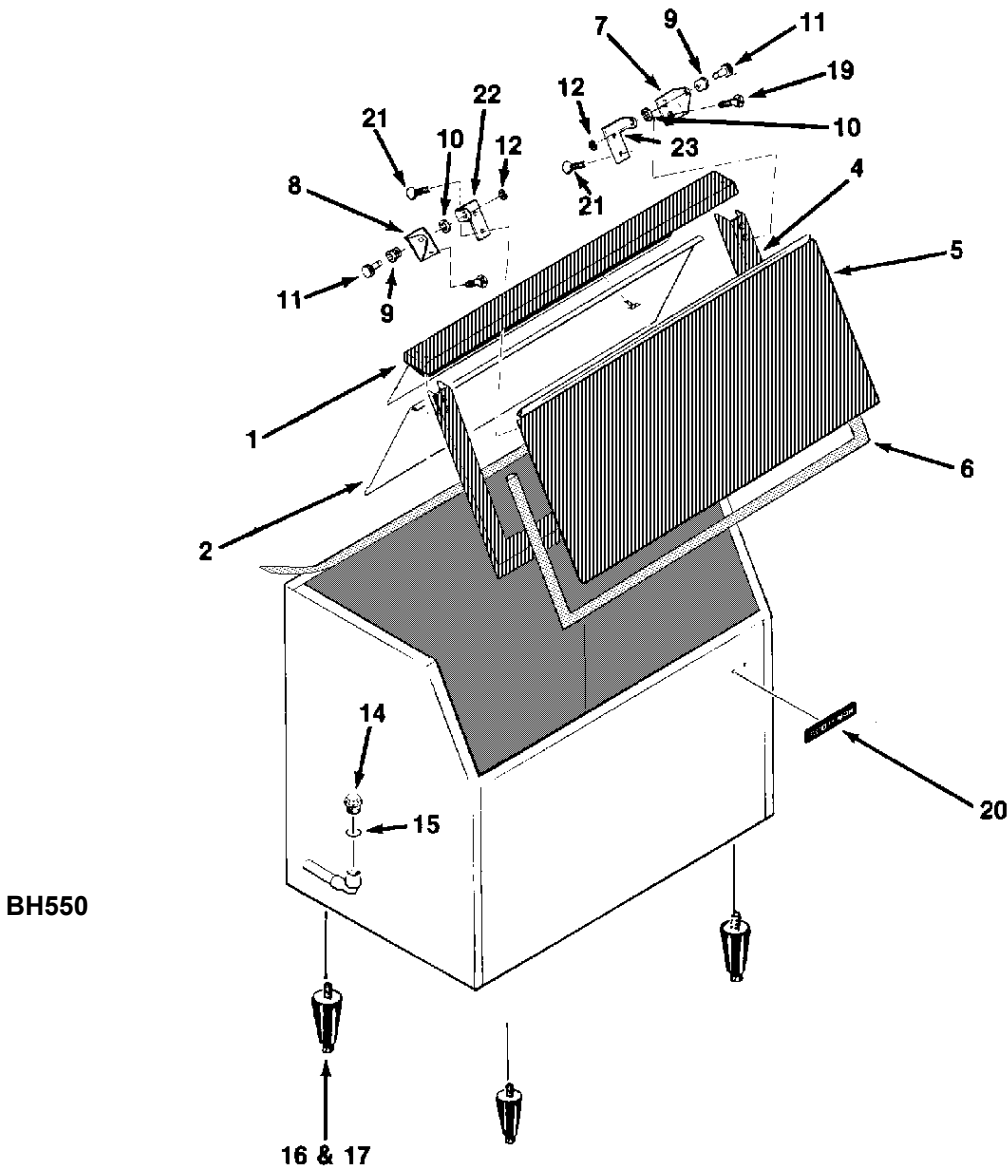

BH550

ITEM NUMBER	PART NUMBER	DESCRIPTION	ITEM NUMBER	PART NUMBER	DESCRIPTION
1	A33921-001	Canopy	15	13-0617-11	O-Ring
2	A32580-001	Baffle	16	KLPE	Leg kit, black
3	19-0503-04	Gasket	17	KLPS	Leg kit, nickel
4	A33922-020	Door Frame	18	03-1404-06	Screw
5	A33938-020	Door	19	03-1360-02	Screw
6	13-0595-00	Door Gasket, 6' req.	20	15-0711-01	Emblem
7	A32396-002	Hinge Right	21	03-1418-41	Screw
8	A32396-001	Hinge Left	22	A32546-001	Door hinge left
9	02-2380-02	Hinge Bushing	23	A32546-002	Door hinge right
10	02-2380-02	Hinge Spacer	24	03-1423-07	Speed nut for baffle
11	02-2806-01	Shoulder Screw	Bottom Drain Parts (not shown) after sn 487440-05K		
12	03-1539-09	E-Clip	25	02-2809-02	Drain top
13	03-0727-06	Thumb Screw	26	13-0617-09	O-ring
14	02-2809-01	Drain Top (back drain)	27	02-3201-01	Drain fitting

CMS1002R SERVICE PARTS

208-230/60/1

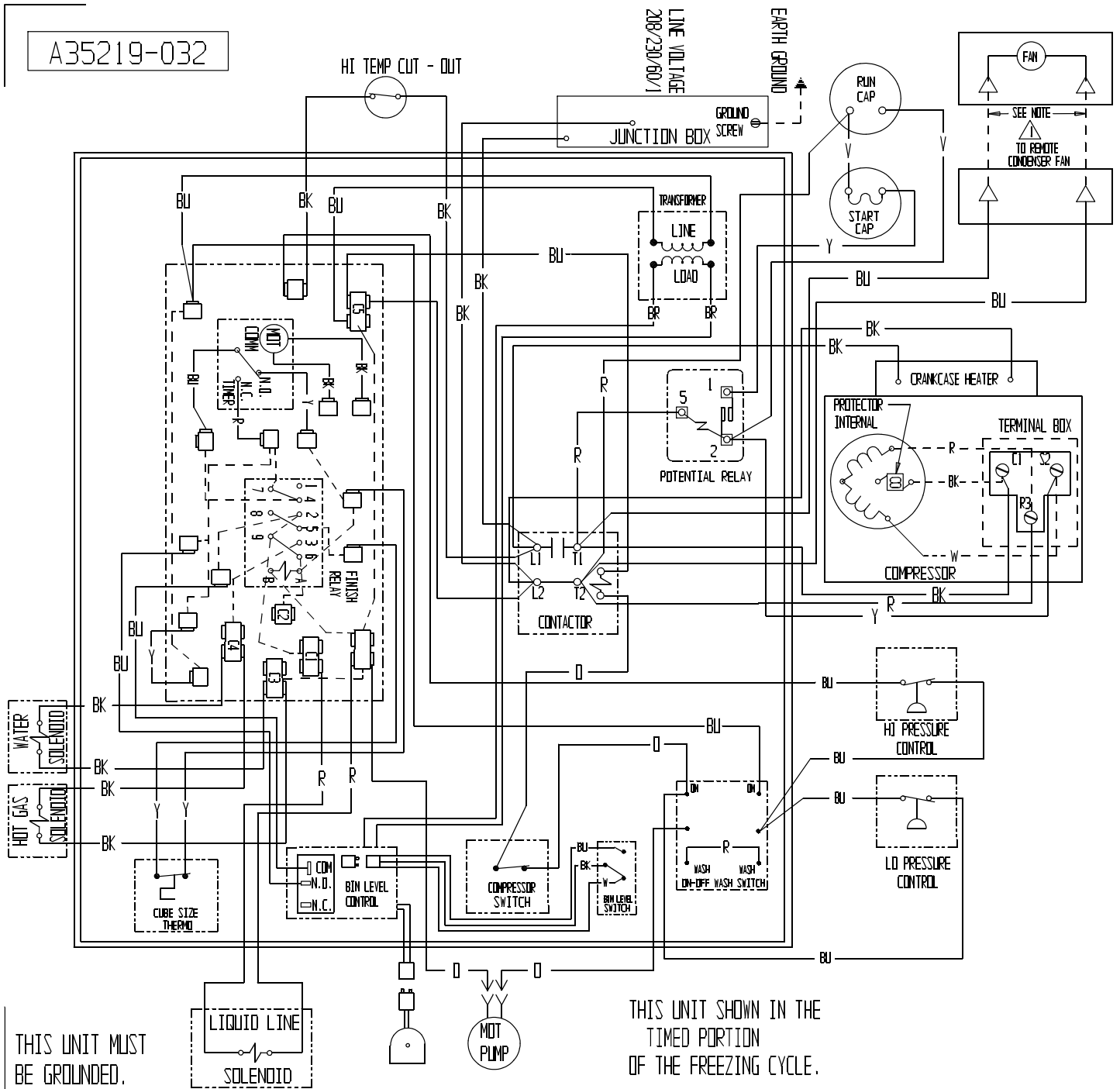

CMS1002R SERVICE PARTS

208-230/60/1

CAUTION:

MORE THAN ONE DISCONNECT MEANS MAY BE REQUIRED TO DISCONNECT ALL POWER TO THIS UNIT.

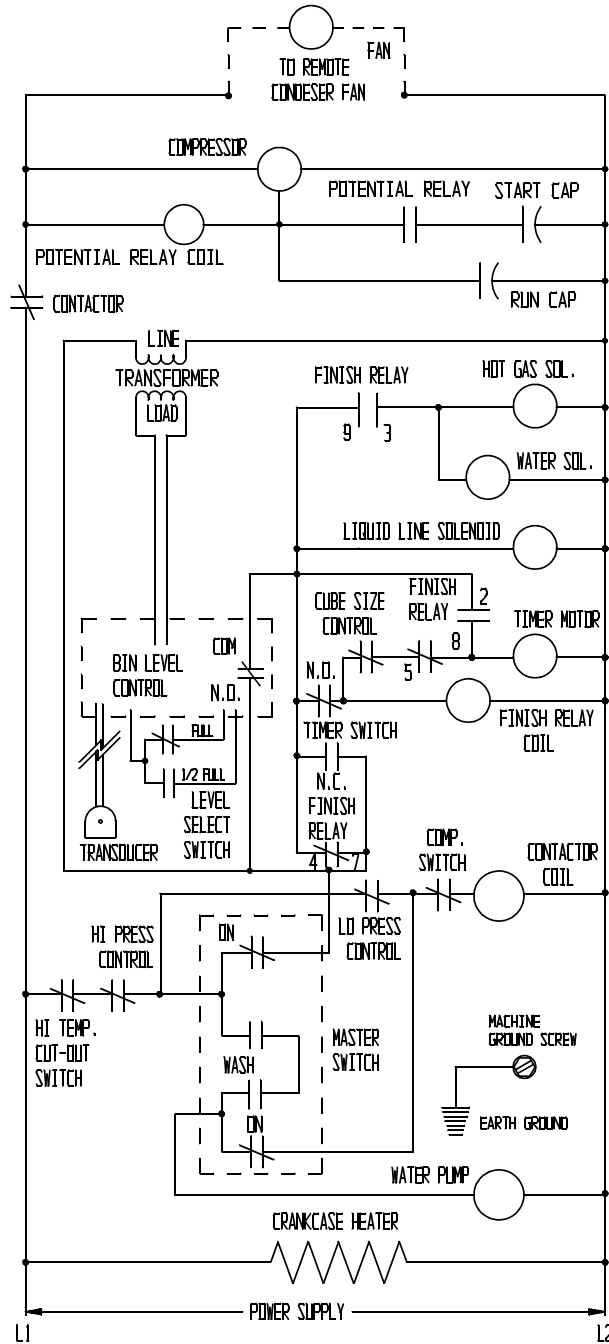

NOTE:

DASHED LINES INDICATE FIELD WIRING WHICH MUST BE INSTALLED IN ACCORDANCE WITH THE NATIONAL ELECTRICAL CODE AND ALL STATE AND LOCAL CODES.

USE COPPER CONDUCTORS ONLY

CMS1002R SERVICE PARTS

208-230/60/3

A35219-003

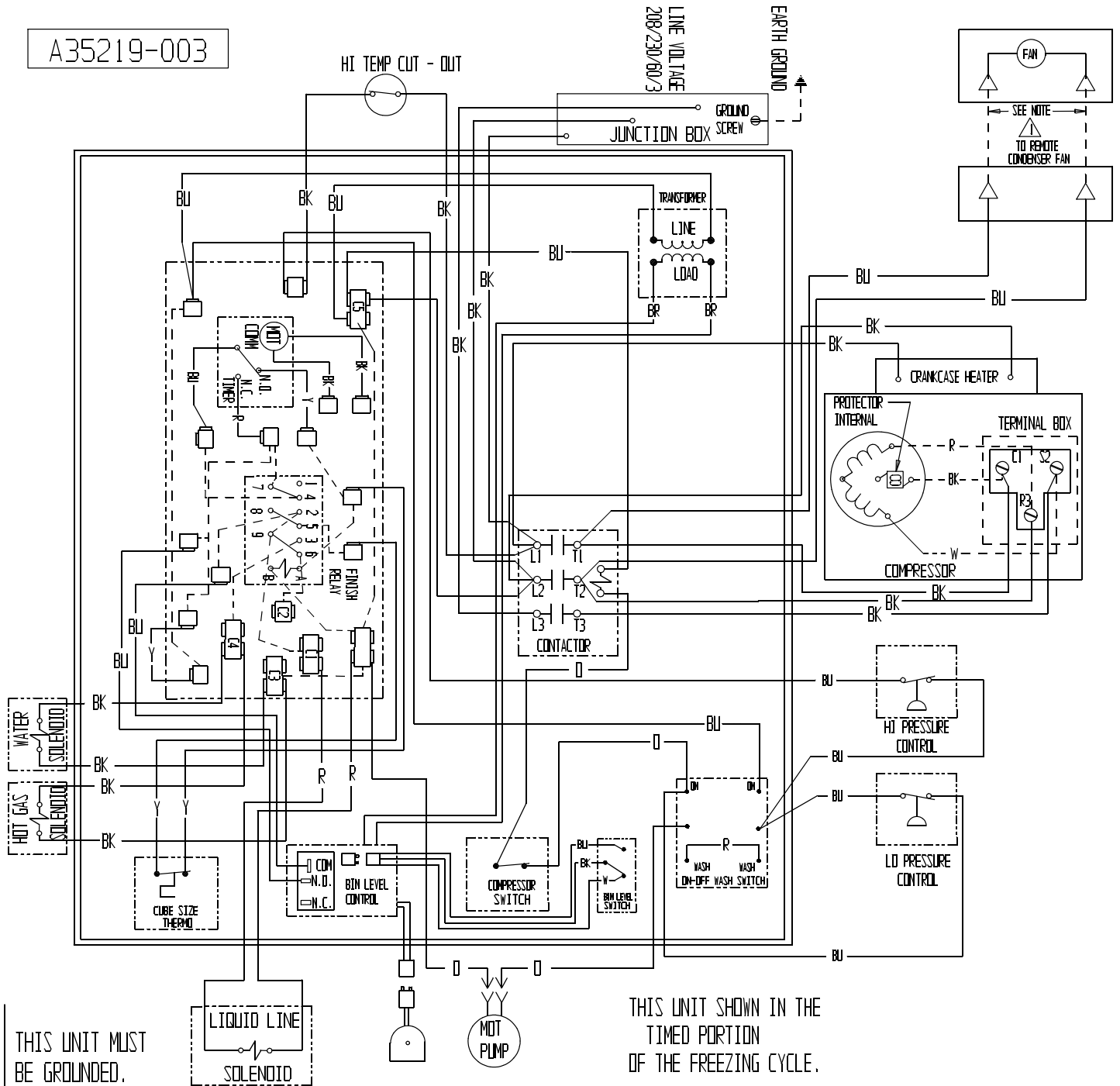

THIS UNIT MUST BE GROUNDED.

THIS UNIT SHOWN IN THE TIMED PORTION OF THE FREEZING CYCLE.

CMS1002R SERVICE PARTS

208-230/60/3

CAUTION:

MORE THAN ONE DISCONNECT MEANS MAY BE REQUIRED TO DISCONNECT ALL POWER TO THIS UNIT.

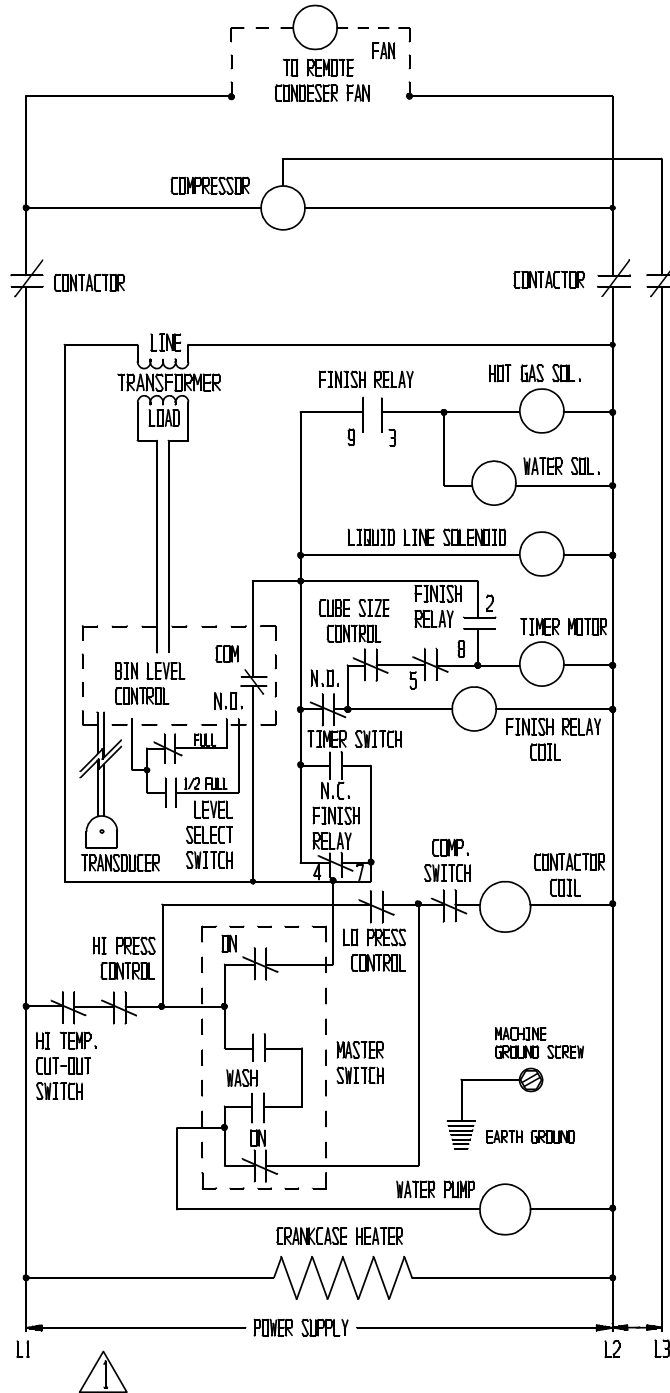

NOTE:
 DASHED LINES INDICATE FIELD WIRING WHICH MUST BE
 INSTALLED IN ACCORDANCE WITH THE NATIONAL ELECTRICAL
 CODE AND ALL STATE AND LOCAL CODES.
 USE COPPER CONDUCTORS ONLY